

Preamplifier for IR Remote Control

Description

The IC U2535B is a complete IR receiver for data communication. The PIN photodiode converts the transmitted IR telegram into electronic input signals. This is separated by a special input circuit. The characteristics (filter, gain) of the following amplifier are determined by external components.

The signal detector, consisting of a comparator, an integrator and a Schmitt trigger, forms the input signal to an output pulse that can be interfaced to a microcomputer.

Features

- Low current requirement (typical 260 μ A/ 12 V)
- Carrier frequencies 20 to 100 kHz
- Supply voltages:
5 or 7 to 16 V with internal stabilization
- Filter characteristics and gain are specified by few external components
- Demodulator with Schmitt trigger
- Open collector output

Applications

- Keyless entry
- Remote control
- Wireless data transfer

Ordering Information

Extended Type Number	Package	Remarks
U2535B-FP	SO8	

Block Diagram

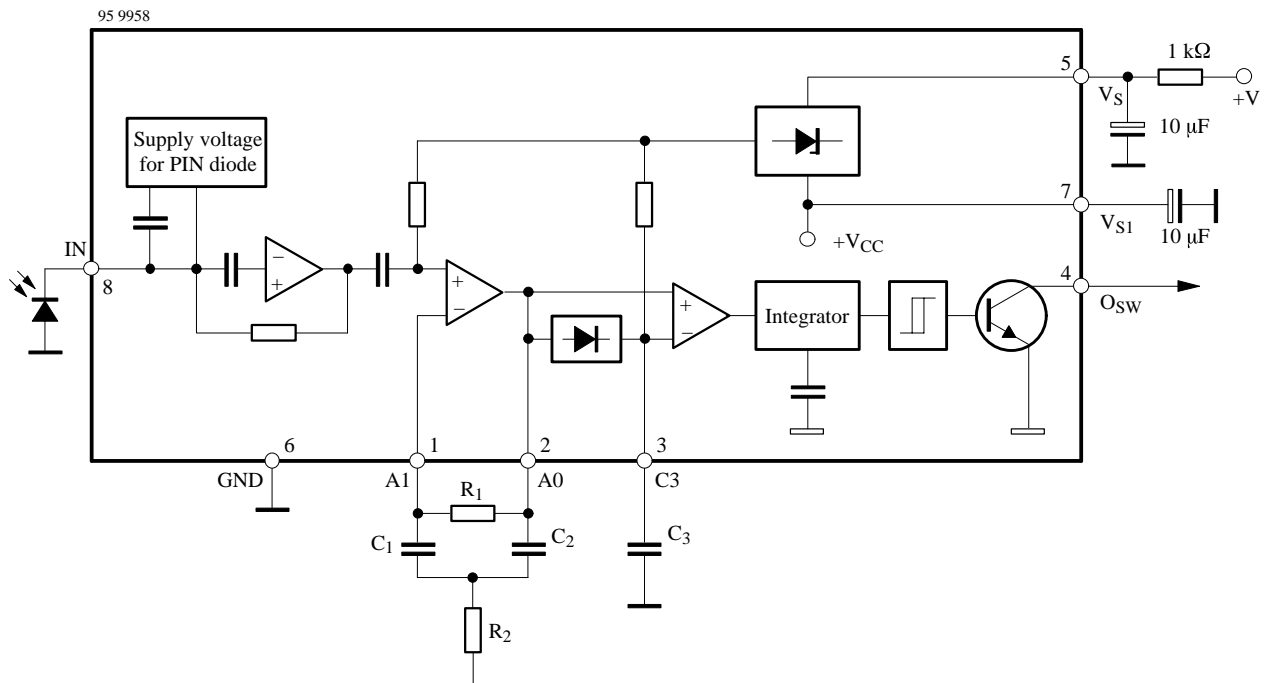

Figure 1. Block diagram

Pin Description

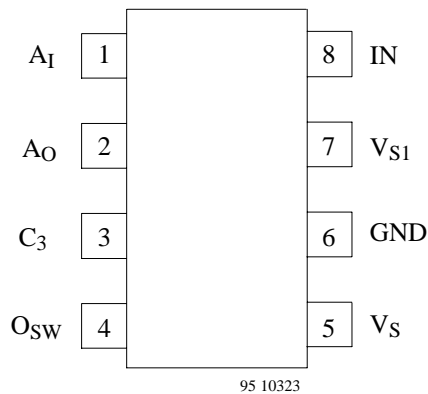

Figure 2. Pinning

Pin	Symbol	Function
1	A _I	Inverting input of bandpass amplifier, pin connection for external filter function
2	A _O	Output of bandpass amplifier
3	C ₃	Capacitor at Pin 3 to reject (suppress) ripple during transmission, also functions as delay time for reference voltage of the comparator
4	O _{SW}	Switching output Open collector output which switches with time delay and turns to LOW (transistor switched ON) when the signal is identified at Pin 2.
5	V _S	Supply voltage The integrated Z-diode (typically 17 V) protects the circuit against positive voltage spikes
6	GND	Ground
7	V _{S1}	Unregulated supply voltage for 5 V operation
8	IN	Input connection for photodiode with regulated bias voltage

Absolute Maximum Ratings

Reference point Pin 6, unless otherwise specified

Parameters	Symbol	Value	Unit
Supply-voltage range	V _S	-0.3 to +16	V
Supply currents: tp ≤ 250 ms	I _S	20	mA
	i _S	150	mA
Input voltages	V _{A(I)}	-0.3 to 5	V
	V _{O(SW)}	-0.3 to 16	V
	V _{IN}	-0.3 to 5	V
Output currents	I _O	±5	mA
Junction temperature	T _j	125	°C
Storage-temperature range	T _{stg}	-40 to +125	°C
Ambient-temperature range	T _{amb}	-40 to +105	°C

Thermal Resistance

Parameters	Symbol	Value	Unit
Junction ambient	R _{thJA}	180	K/W

Electrical Characteristics

$T_{amb} = 25^{\circ}\text{C}$, reference point Pin 6, test circuit, unless otherwise specified

Parameters	Test Conditions / Pins	Symbol	Min.	Typ.	Max.	Unit
Supply currents	$V_{S1} = 5\text{ V}$, $I_{IN} = 0$, Pin 7	I_{S1}	140		200	μA
	$V_S = 12\text{ V}$, $I_{IN} = 0$, Pin 5	I_S	200		320	μA
Internal stabilization	$V_S = 12\text{ V}$, $I_{IN} = 0$, Pin 7	V_{S1}	4.9		5.4	V
Maximum input current	$V_{S1} = 5\text{ V}$, $V_{IN} = 0$, Pin 8	$-I_{IN}$	0.8		1.2	mA
Low-level voltage	$V_{S1} = 5\text{ V}$, $I_{OL} = 0.5\text{ mA}$ Pin 4	V_{OL}			0.2	V
Leakage current	$V_{S1} = 5\text{ V}$, $V_0 = 12\text{ V}$, Pin 4	I_{OH}			1	μA
Input stage, amplifier						
Cut-off frequency		f_L			15	kHz
		f_H	100			kHz
Gain	$v_i = 2\text{ mV}_{\text{rms}}$, $f = 40\text{ kHz}$ $f = 100\text{ kHz}$	G_v	47	50		dB
		G_v	46	49		dB
Detector						
Threshold voltage	$t_d \leq 200\ \mu\text{s}$, $f = 40\text{ kHz}$, Pin 2	V_{A0}		150		mV_{rms}
Delay time	$f = 40\text{ kHz}$, $V_{A0} = 1\text{ V}_{\text{rms}}$ see figure 4	t_d	50	90		μs
Storage time	$f = 40\text{ kHz}$, $V_{A0} = 1\text{ V}_{\text{rms}}$ see figure 4	t_s	100		150	μs

Test Circuit

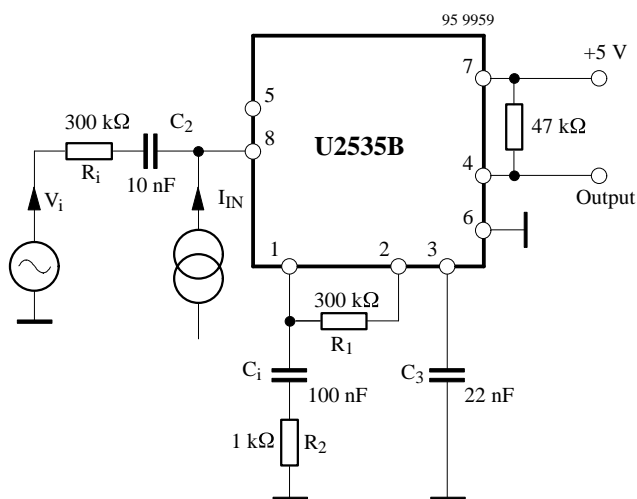

Figure 3. Test circuit

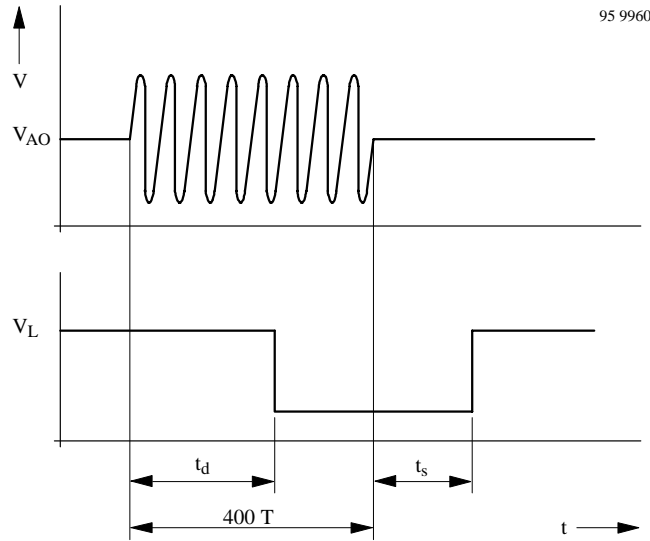

Figure 4. Waveforms for t_d and t_s measurement

Application Circuit

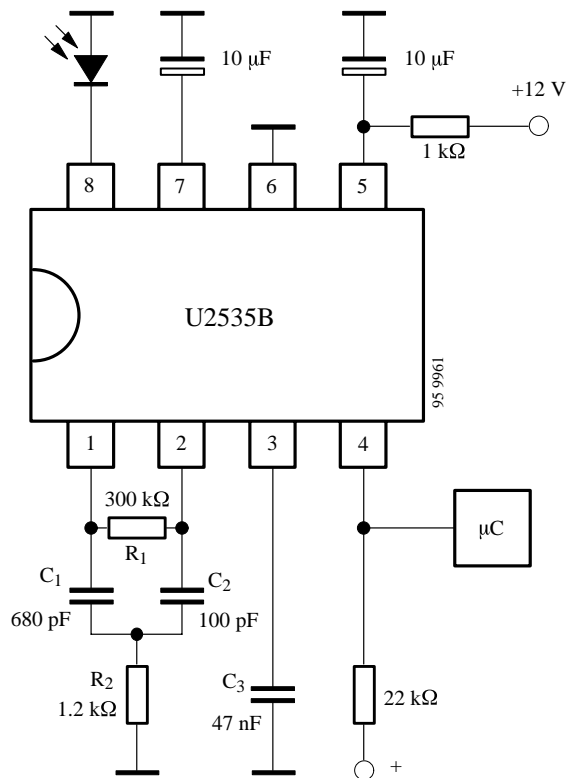

Figure 5. Application circuit

Bandpass Filter Design

Center frequency

$$f_0 = \frac{1}{2\pi \sqrt{R_1 \times C_1 \times R_2 \times C_2}}$$

$$\text{GAIN} \approx \frac{R_1 \times C_1}{R_2 (C_1 + C_2)} \quad \begin{array}{l} R_1 \gg R_2 \\ C_1 \cong C_2 \end{array}$$

$$\text{Bandwidth} \approx \frac{C_1 + C_2}{2\pi \times R_1 \times C_1 \times C_2} \quad \text{BW} \ll f_0$$

Note: R_1 should be about 300 k Ω .
Results can be influenced by feedback (Pin 2 \rightarrow Pin 8)

Package Information

Package SO8

Dimensions in mm

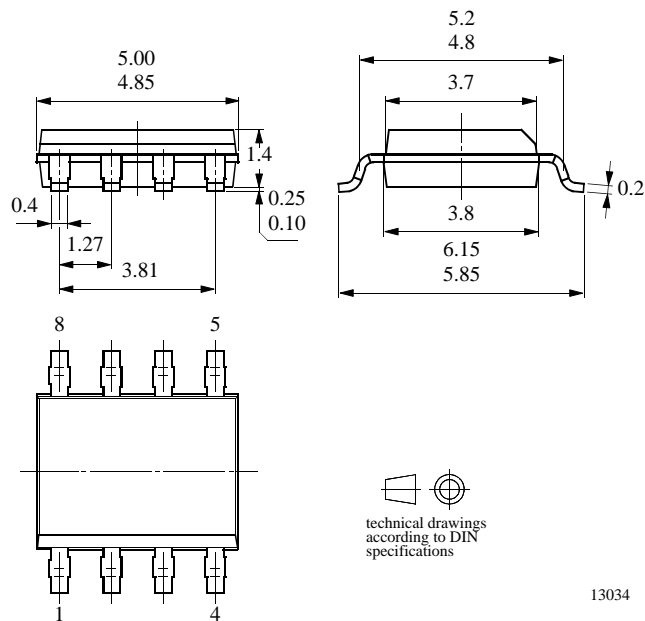

Ozone Depleting Substances Policy Statement

It is the policy of **TEMIC Semiconductor GmbH** to

1. Meet all present and future national and international statutory requirements.
2. Regularly and continuously improve the performance of our products, processes, distribution and operating systems with respect to their impact on the health and safety of our employees and the public, as well as their impact on the environment.

It is particular concern to control or eliminate releases of those substances into the atmosphere which are known as ozone depleting substances (ODSs).

The Montreal Protocol (1987) and its London Amendments (1990) intend to severely restrict the use of ODSs and forbid their use within the next ten years. Various national and international initiatives are pressing for an earlier ban on these substances.

TEMIC Semiconductor GmbH has been able to use its policy of continuous improvements to eliminate the use of ODSs listed in the following documents.

1. Annex A, B and list of transitional substances of the Montreal Protocol and the London Amendments respectively
2. Class I and II ozone depleting substances in the Clean Air Act Amendments of 1990 by the Environmental Protection Agency (EPA) in the USA
3. Council Decision 88/540/EEC and 91/690/EEC Annex A, B and C (transitional substances) respectively.

TEMIC Semiconductor GmbH can certify that our semiconductors are not manufactured with ozone depleting substances and do not contain such substances.

We reserve the right to make changes to improve technical design and may do so without further notice.

Parameters can vary in different applications. All operating parameters must be validated for each customer application by the customer. Should the buyer use TEMIC products for any unintended or unauthorized application, the buyer shall indemnify TEMIC against all claims, costs, damages, and expenses, arising out of, directly or indirectly, any claim of personal damage, injury or death associated with such unintended or unauthorized use.

TEMIC Semiconductor GmbH, P.O.B. 3535, D-74025 Heilbronn, Germany
Telephone: 49 (0)7131 67 2594, Fax number: 49 (0)7131 67 2423