



ULTRA-PRECISION 1:8 FANOUT BUFFER WITH LVPECL OUTPUTS AND INTERNAL TERMINATION

Precision Edge®
SY58032U

FEATURES

- Precision 1:8, LVPECL fanout buffer
- Guaranteed AC performance over temperature and voltage:
 - Clock frequency range: DC to 4GHz
 - <110ps t_r / t_f times
 - <330ps t_{pd}
 - <20ps skew
- Low-jitter performance:
 - <10ps_{pp} total jitter (clock)
 - <1ps_{RMS} random jitter
- 100k LVPECL compatible outputs
- Fully differential inputs/outputs
- Accepts an input signal as low as 100mV
- Unique input termination and V_T pin accepts DC-coupled and AC-coupled differential inputs: (LVPECL, LVDS, and CML)
- Power supply 2.5V ±5% or 3.3V ±10%
- Industrial temperature range: -40°C to +85°C
- Available in 32-pin (5mm × 5mm) MLF™ package



Precision Edge®

DESCRIPTION

The SY58032U is a 2.5V/3.3V precision, high-speed, fully differential LVPECL 1:8 fanout buffer. The SY58032U is optimized to provide eight identical output copies with less than 20ps of skew and less than 10ps_{pp} total jitter. It can process clock signals as fast as 4GHz.

The differential input includes Micrel's unique, 3-pin input termination architecture that allows the SY58032U to directly interface to LVPECL, CML, and LVDS differential signals (AC- or DC-coupled) without any level-shifting or termination resistor networks in the signal path. The result is a clean, stub-free, low-jitter interface solution. The LVPECL (100k temperature compensated) outputs feature 800mV typical swing into 50Ω loads, and provide an extremely fast rise/fall time guaranteed to be less than 110ps.

The SY58032U operates from a 2.5V ±5% supply or 3.3V ±10% supply and is guaranteed over the full industrial temperature range (-40°C to +85°C). For applications that require a higher high-speed 1:8 fanout buffer, consider the SY58031U or SY58033U. The SY58032U is part of Micrel's high-speed, Precision Edge® product line.

All support documentation can be found on Micrel's web site at www.micrel.com.

APPLICATIONS

- All SONET and all GigE clock distribution
- All Fibre Channel clock and data distribution
- Network routing engine timing distribution
- High-end, low-skew multiprocessor synchronous clock distribution

FUNCTIONAL BLOCK DIAGRAM

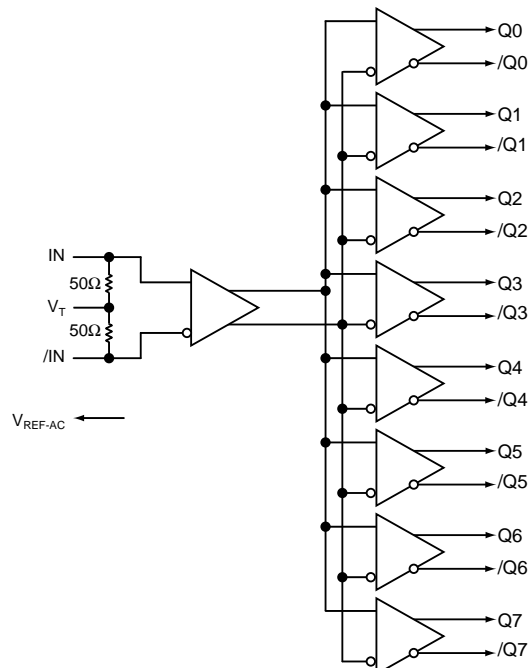

Precision Edge is a registered trademark of Micrel, Inc.
MicroLeadFrame and MLF are trademarks of Amkor Technology, Inc.

PACKAGE/ORDERING INFORMATION

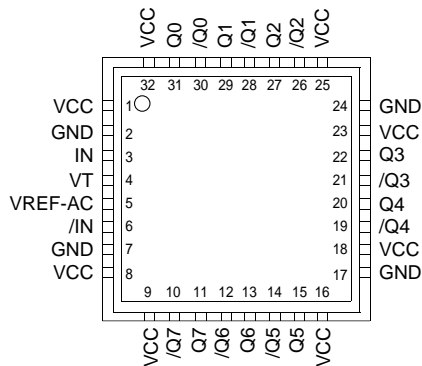

32-Pin MLF™ (MLF-32)

Ordering Information⁽¹⁾

Part Number	Package Type	Operating Range	Package Marking	Lead Finish
SY58032UMI	MLF-32	Industrial	SY58032U	Sn-Pb
SY58032UMITR ⁽²⁾	MLF-32	Industrial	SY58032U	Sn-Pb
SY58032UMG ⁽³⁾	MLF-32	Industrial	SY58032U with Pb-Free bar-line indicator	Pb-Free NiPdAu
SY58032UMGTR ^(2, 3)	MLF-32	Industrial	SY58032U with Pb-Free bar-line indicator	Pb-Free NiPdAu

Notes:

1. Contact factory for die availability. Dice are guaranteed at T_A = 25°C, DC electricals only.
2. Tape and Reel.
3. Recommended for new designs.

PIN DESCRIPTION

Pin Number	Pin Name	Pin Function
3, 6	IN, /IN	Differential Signal Input: Each pin of this pair internally terminates with 50Ω to the V _T pin. Note that this input will default to an indeterminate state if left open. See “Input Interface Applications” section.
4	VT	Input Termination Center-Tap: Each input terminates to this pin. The V _T pin provides a center-tap for each input (IN, /IN) to the termination network for maximum interface flexibility. See “Input Interface Applications” section.
2, 7, 17, 24	GND, Exposed Pad	Ground. Exposed pad must be connected to a ground plane that is the same potential as the ground pin.
1, 8, 9, 16, 18, 23, 25, 32	VCC	Positive Power Supply: Bypass with 0.1μF 0.01μF low ESR capacitors as close to the pins as possible.
31, 30, 29, 28, 27, 26, 22, 21, 20, 19, 15, 14, 13, 12, 11, 10	Q0, /Q0, Q1, /Q1, Q2, /Q2, Q3, /Q3, Q4, /Q4, Q5, /Q5, Q6, /Q6, Q7, /Q7	100k LVPECL Differential Output Pairs: Differential buffered output copy of the input signal. The LVPECL output swing is typically 800mV into 50Ω. Unused output pairs may be left floating with no impact on jitter. See “LVPECL Output” section.
5	VREF-AC	Bias Reference Voltage: Equal to V _{CC} -1.2V (typical), and used for AC-coupled applications. See “Input Interface Applications” section. When using V _{REF-AC} , bypass with 0.01μF capacitor to V _{CC} . Maximum sink/source current is 0.5mA.

Absolute Maximum Ratings⁽¹⁾

Power Supply Voltage (V_{CC}) -0.5V to +4.0V
 Input Voltage (V_{IN}) -0.5V to V_{CC}
 Current (V_T)
 Source or sink current on V_T pin ± 100 mA
 Input Current (V_T)
 Source or sink current on IN, /IN ± 50 mA
 Current (V_{REF})
 Source or sink current on V_{REF-AC} ⁽³⁾ ± 1.5 mA
 Lead Temperature Soldering, (20 sec.) 260°C
 Storage Temperature Range (T_S) -65°C to +150°C

Operating Ratings⁽²⁾

Power Supply Voltage (V_{CC}) +2.375V to +3.60V
 Ambient Temperature Range (T_A) -40°C to +85°C
 Package Thermal Resistance⁽⁴⁾
 MLF™ (θ_{JA})
 Still-Air 35°C/W
 MLF™ (ψ_{JB})
 Junction-to-Board 20°C/W

DC ELECTRICAL CHARACTERISTICS⁽⁵⁾

$T_A = -40^\circ\text{C}$ to $+85^\circ\text{C}$

Symbol	Parameter	Condition	Min	Typ	Max	Units
V_{CC}	Power Supply Voltage	2.5V nominal 3.3V nominal	2.375 3.0	2.5 3.3	2.625 3.6	V
I_{CC}	Power Supply Current	$V_{CC} = \text{max.}$ No load. Includes current through 50Ω pull-ups.		190	250	mA
V_{IH}	Input HIGH Voltage	IN, /IN; Note 6.	$V_{CC}-1.6$		V_{CC}	V
V_{IL}	Input LOW Voltage	IN, /IN	0		$V_{IH}-0.1$	V
V_{IN}	Input Voltage Swing	IN, /IN, see Figure 1a.	0.1		1.7	V
V_{DIFF_IN}	Differential Input Voltage Swing IN0, /IN0 , IN1, /IN1	IN, /IN, see Figure 1b.	0.2			V
R_{IN}	In-to- V_T Resistance		40	50	60	Ω
$V_{T\ IN}$	Max. In-to- V_T (IN, /IN)				1.28	V
V_{REF-AC}			$V_{CC}-1.3$	$V_{CC}-1.2$	$V_{CC}-1.1$	V

LVPECL DC ELECTRICAL CHARACTERISTICS⁽⁵⁾

$V_{CC} = 2.5\text{V} \pm 5\%$ or $3.3\text{V} \pm 10\%$; $R_L = 50\Omega$ to $V_{CC}-2\text{V}$; $T_A = -40^\circ\text{C}$ to $+85^\circ\text{C}$, unless otherwise stated.

Symbol	Parameter	Condition	Min	Typ	Max	Units
V_{OH}	Output HIGH Voltage		$V_{CC}-1.145$		$V_{CC}-0.895$	V
V_{OL}	Output LOW Voltage		$V_{CC}-1.945$		$V_{CC}-1.695$	V
V_{OUT}	Output Voltage Swing	see Figure 1a.	500	800		mV
V_{DIFF_OUT}	Differential Voltage Swing	see Figure 1b.	1000	1600	2000	mV

Notes:

1. Permanent device damage may occur if Absolute Maximum Ratings are exceeded. This is a stress rating only and functional operation is not implied at conditions other than those detailed in the operational sections of this data sheet. Exposure to Absolute Maximum Ratings conditions for extended periods may affect device reliability.
2. The data sheet limits are not guaranteed if the device is operated beyond the operating ratings.
3. Due to the limited drive capability, use for input of the same package only.
4. Thermal performance assumes exposed pad is soldered (or equivalent) to the device's most negative potential (GND) on the PCB. ψ_{JB} uses 4-layer θ_{JA} in still-air number unless otherwise stated.
5. The circuit is designed to meet the DC specifications shown in the above tables after thermal equilibrium has been established.
6. V_{IH} (min) not lower than 1.2V.

AC ELECTRICAL CHARACTERISTICS⁽⁷⁾

$V_{CC} = 2.5V \pm 5\%$ or $3.3V \pm 10\%$; $R_L = 50\Omega$ to $V_{CC} - 2V$; $T_A = -40^\circ C$ to $+85^\circ C$, unless otherwise stated.

Symbol	Parameter	Condition	Min	Typ	Max	Units
f_{MAX}	Maximum Operating Frequency	$V_{OUT} \geq 400mV$ Clock	4			GHz
t_{pd}	Propagation Delay (IN-to-Q)		180	260	330	ps
$t_{pd\ tempco}$	Differential Propagation Delay Temperature Coefficient			35		fs/°C
t_{SKEW}	Output-to-Output Skew (within Device)	Note 8		7	20	ps
	Part-to-Part Skew	Note 9			100	ps
t_{JITTER}	Clock Cycle-to-Cycle Jitter	Note 10			1	ps _{RMS}
	Total Jitter (Clock)	Note 11			10	ps _{PP}
	Random Jitter (RJ)	Note 12			1	ps _{RMS}
t_r, t_f	Output Rise/Fall Time	20% to 80%, at full output swing.	35	75	110	ps

Notes:

- High frequency AC electricals are guaranteed by design and characterization. All outputs loaded with 50Ω to $V_{CC} - 2V$, $V_{IN} \geq 100mV$.
- Output-to-output skew is measured between outputs under identical transitions.
- Part-to-part skew is defined for two parts with identical power supply voltages at the same temperature and with no skew of the edges at the respective inputs. Part-to-part skew includes variation in t_{pd} .
- Cycle-to-cycle jitter definition: the variation of periods between adjacent cycles, $T_n - T_{n-1}$ where T is the time between rising edges of the output signal.
- Total jitter definition: with an ideal clock input of frequency $\leq f_{MAX}$, no more than one output edge in 10^{12} output edges will deviate by more than the specified peak-to-peak jitter value.
- Random jitter is measured with a K28.7 comma detect character pattern, measured at 1.25Gbps and 2.5Gbps.

SINGLE-ENDED AND DIFFERENTIAL SWINGS

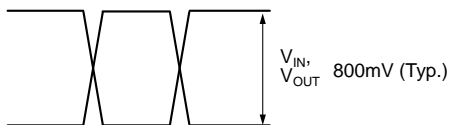

Figure 1a. Single-Ended Voltage Swing

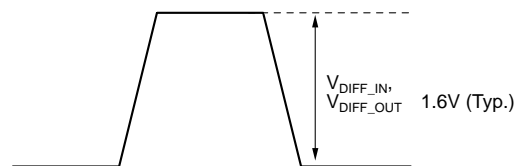
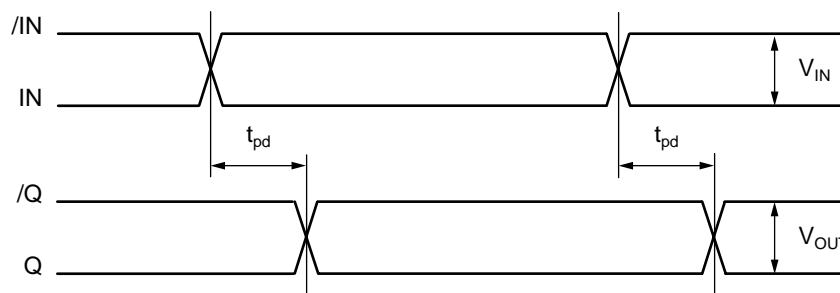

Figure 1b. Differential Voltage Swing

TIMING DIAGRAM



TYPICAL OPERATING CHARACTERISTICS

$V_{CC} = 2.5V$, $GND = 0$, $V_{IN} = 100mV$, $T_A = 25^\circ C$, unless otherwise stated.

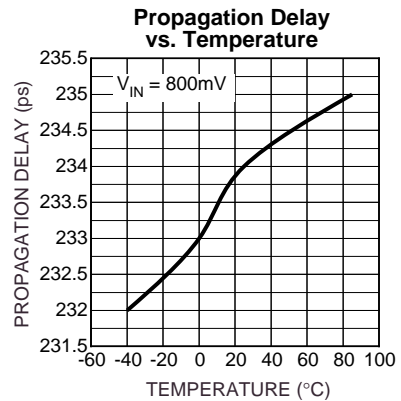
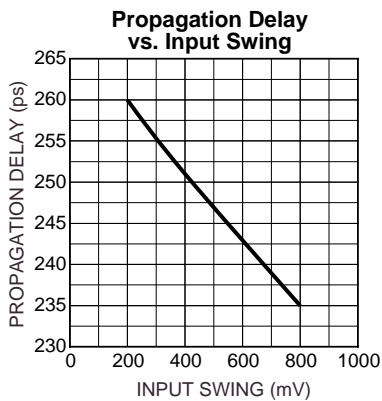
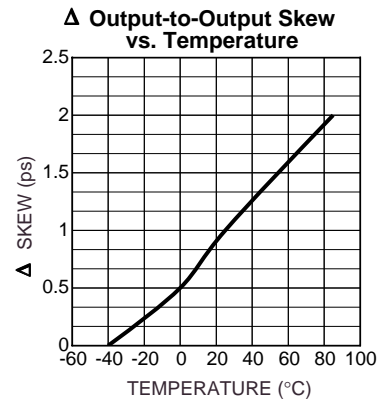
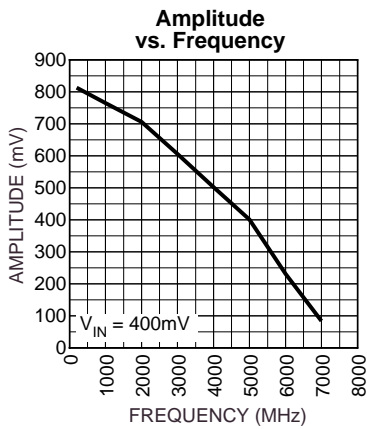
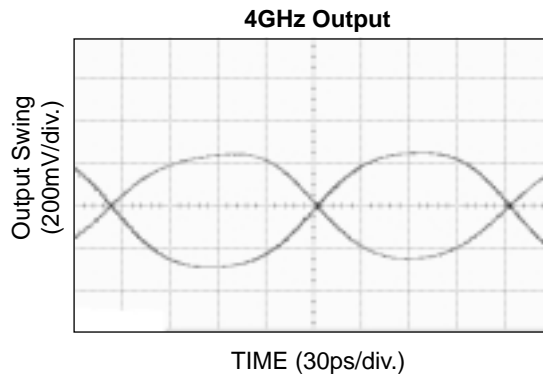
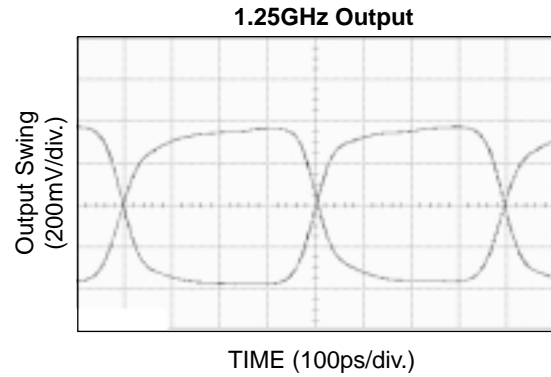
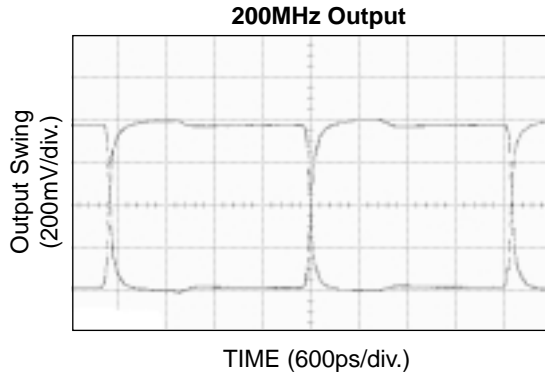

INPUT BUFFER

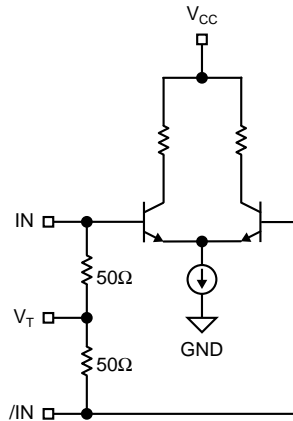

Figure 2. Simplified Differential Input Buffer

INPUT INTERFACE APPLICATIONS

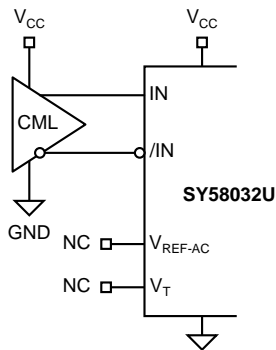

Figure 3a. DC-Coupled CML Input Interface
Option: May connect V_T to V_{CC} .

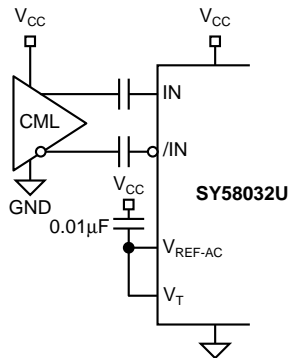
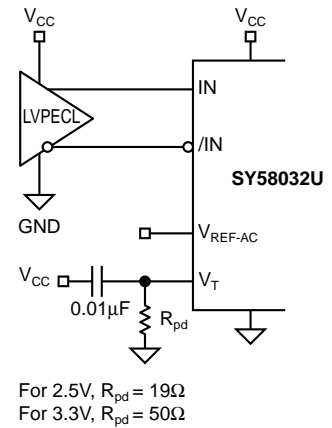
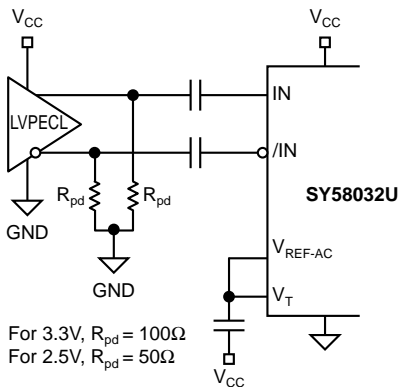

Figure 3b. AC-Coupled CML Input Interface



For 2.5V, $R_{pd} = 19\Omega$
For 3.3V, $R_{pd} = 50\Omega$

Figure 3c. LVPECL Input Interface



For 3.3V, $R_{pd} = 100\Omega$
For 2.5V, $R_{pd} = 50\Omega$

Figure 3d. AC-Coupled LVPECL Input Interface

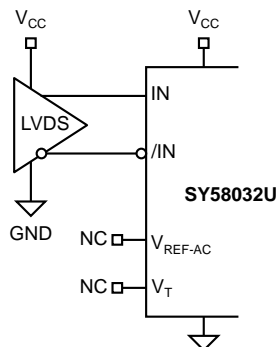

Figure 3e. LVDS Input Interface

LVPECL OUTPUT

LVPECL has high input impedance, and very low output impedance (open emitter), and small signal swing which results in low EMI. LVPECL is ideal for driving 50Ω and 100Ω controlled impedance transmission lines. There are several techniques for terminating the LVPECL

output: Parallel Termination-Thevenin Equivalent, Parallel Termination (3-resistor), and AC-coupled Termination. Unused output pairs may be left floating. However, single-ended outputs must be terminated, or balanced.

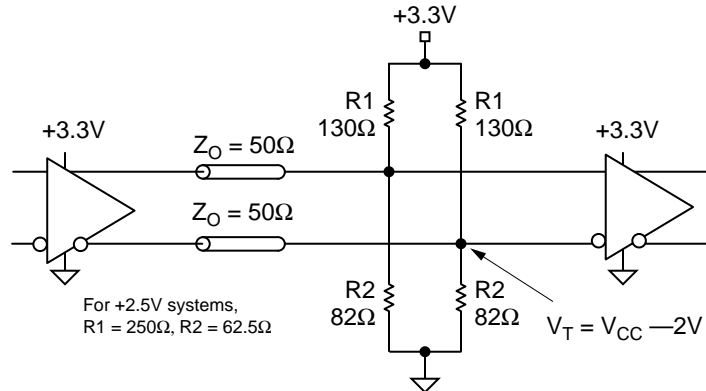
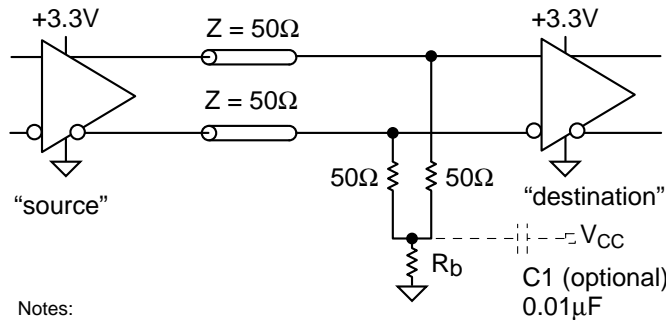

Figure 4. Parallel Termination-Thevenin Equivalent



- Notes:
1. Power-saving alternative to Thevenin termination.
 2. Place termination resistors as close to destination inputs as possible.
 3. R_b resistor sets the DC bias voltage, equal to V_T.
 4. For 2.5V systems, R_b = 19Ω, For 3.3V systems, R_b = 50Ω

Figure 5. Parallel Termination (3-Resistor)

RELATED MICREL PRODUCTS AND SUPPORT DOCUMENTATION

Part Number	Function	Data Sheet Link
SY58031U	Ultra-Precision 1:8 Fanout Buffer with 400mV CML Outputs and Internal I/O Termination	http://www.micrel.com/product-info/products/sy58031u.shtml
SY58032U	Ultra-Precision 1:8 Fanout Buffer with LVPECL Outputs and Internal Termination	http://www.micrel.com/product-info/products/sy58032u.shtml
SY58033U	Ultra-Precision 1:8 Fanout Buffer with 400mV LVPECL Outputs and Internal Termination	http://www.micrel.com/product-info/products/sy58033u.shtml
	32-MLF™ Manufacturing Guidelines Exposed Pad Application Note	www.amkor.com/products/notes_papers/MLF_AppNote_0902.pdf
	HBW Solutions	http://www.micrel.com/product-info/as/solutions.shtml