

**KEYBOARD ENCODER (JIS CODE STANDARD PRODUCT)**

**DESCRIPTION**

The M58609-04P, S is a keyboard encoder for reed switches of terminal equipment. It is fabricated using P-channel aluminum-gate MOS technology and is packaged in a 40-pin DIL package. It contains a 3168-bit mask-programmable read-only memory, and the 8-bit codes specified in JIS C-6220-1969 "Codes for Information Interchange" are stored in the ROM. The output consists of an 8-bit code and a parity bit. The address is selected by the 8-bit and 11-bit ring counters.

**FEATURES**

- TTL/DTL-compatible (except X, Y terminals)
- Two-key rollover operation
- Self-contained clock generator circuit
- Strobe delay circuit for eliminating key contact bounce
- External control for output polarity (positive or negative logic)
- External control for selecting odd or even parity

**APPLICATION**

- Encoder for full-keyboard terminal equipment

**FUNCTION**

Outputs ( $X_0 \sim X_7$ ) of the 8-bit ring counter and inputs ( $Y_0 \sim Y_{10}$ ) of the 11-bit comparator are wired to the keyboard to form an 8x11 (88-cross points) switch matrix.

When the key connected with  $X_i$  and  $Y_j$  is depressed, a path is formed between them. When the level of  $Y_j$  matches that of  $X_i$ , which comes from the 8-bit ring counter, the comparator generates a coincidence signal for clock control and delay circuit. This clock control stops the clock signals

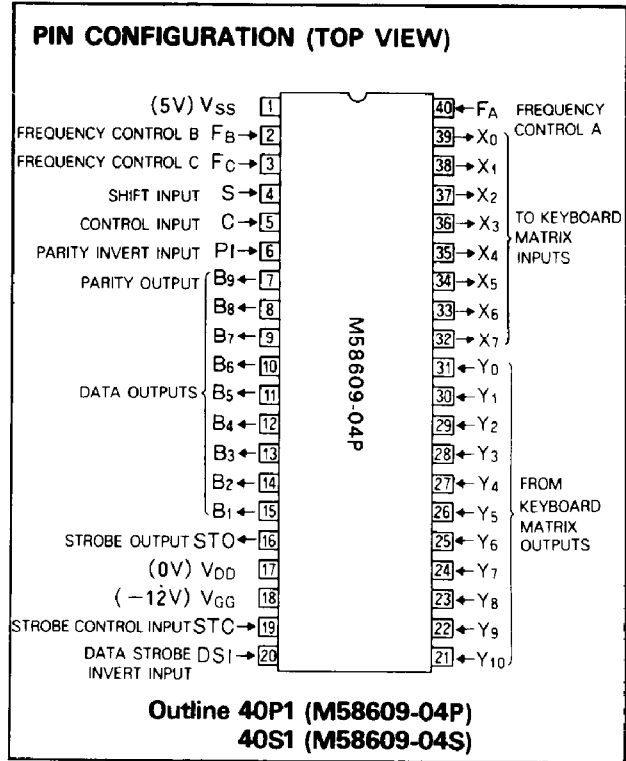

to the ring counter and data outputs ( $B_1 \sim B_9$ ) stabilizing the selected 9-bit code. The stabilization is indicated by a valid signal on the strobe output. A strobe output signal is generated at the time set by the externally controlled delay circuit which receives the coincidence signal. Data outputs and strobe output remain stable until the key is released.

9

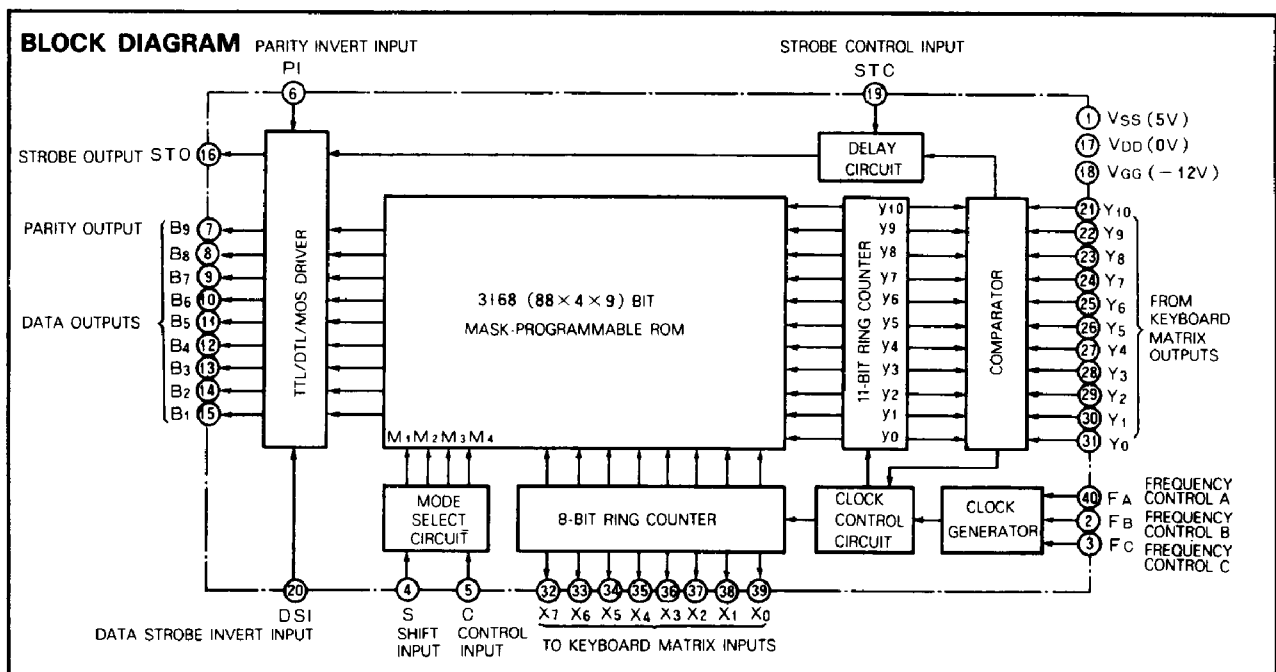

# M58609-04P, S

## KEYBOARD ENCODER (JIS CODE STANDARD PRODUCT)

### FUNCTION (Data Output and Parity Output)

The relationships between  $B_1 \sim B_8$  in the code table and  $B_1 \sim B_8$  in data outputs are shown in Table 1, and those between the parity output  $B_9$  and the parity bit, in Table 2. The parity bit in the table is defined as a '0' when the number of '1's in the code  $B_1 \sim B_8$  is odd and a '1' when it is even.

Mode selection is shown in Table 3.

Table 1 Relationship between code table and data outputs

$B_1 \sim B_8$ Code table	Data strobe invert input DSI	Data output $B_1 \sim B_8$	Logic
1	L	H	Positive logic
1	H	L	Negative logic
0	L	L	Positive logic
0	H	H	Negative logic

Table 2 Parity output

Parity bit	Parity invert input PI	Parity output $B_9$
1	L	H
1	H	L
0	L	L
0	H	H

Table 3 Mode selection

Shift input S	Control input C	Selected mode
L	L	1
H	L	2
L	H	3
H	H	4

### CODE TABLE (JIS C-6220-1969)

NUMBER OF BITS	$B_8 \sim B_1$								ROW	COL	CODE															
	$B_8$	$B_7$	$B_6$	$B_5$	$B_4$	$B_3$	$B_2$	$B_1$			0	1	2	3	4	5	6	7	8	9	10	11	12	13	14	15
	0	0	0	0	0	0	0	0	0	0	1	1	1	1	1	1	1	1	1	1	1	1	1	1	1	
	0	0	0	0	1	1	1	1	1	1	0	0	0	0	1	1	1	1	1	1	1	1	1	1	1	
	0	0	1	1	0	0	1	1	1	1	0	0	1	1	1	0	0	1	1	0	0	1	1	1	1	
	0	1	0	0	0	4	EOT																			
	0	1	0	1	5	ENQ	NAK	%	5	E	U															
	0	1	1	0	6	ACK	SYN	&	6	F	V															
	0	1	1	1	7	BEL	ETB	'	7	G	W															
	1	0	0	0	8	BS	CAN	(	8	H	X															
	1	0	0	1	9	HT	EM	)	9	I	Y															
	1	0	1	0	10	LF	SUB	*	:	J	Z															
	1	0	1	1	11	VT	ESC	+	:	K	{															
	1	1	0	0	12	FF		.	<	L	¥															
	1	1	0	1	13	CR		-	=	M	}															
	1	1	1	0	14	SO		.	>	N	^															
	1	1	1	1	15	SI		/	?	O	-															

\*  $B_9$  is an odd parity bit for the 8-bit code ( $B_1 \sim B_8$ )

Note 1: A '1' or '0' in the code table indicates that the output level goes high for '1' and low for '0' when input DSI and PI are low-level.

KEYBOARD ENCODER (JIS CODE STANDARD PRODUCT)

CODE ARRANGEMENT TABLE

Y <sub>i</sub> \ X <sub>i</sub>	Mode	X <sub>0</sub>	X <sub>1</sub>	X <sub>2</sub>	X <sub>3</sub>	X <sub>4</sub>	X <sub>5</sub>	X <sub>6</sub>	X <sub>7</sub>
Y <sub>0</sub>	1	NUL	DLE	へ	0	;	L	0	9
	2	NUL	DLE	—	NUL	+	NUL	NUL	)
	3	NUL	DLE	へ	ワ	レ	リ	ラ	ヨ
	4	NUL	DLE	NUL	ヲ	NUL	NUL	NUL	ョ
Y <sub>1</sub>	1	SOH	6	0	—	/	K	I	8
	2	SOH	6	0	=	?	NUL	NUL	(
	3	SOH	6	0	ホ	メ	ノ	ニ	ユ
	4	SOH	6	0	NUL	・	NUL	NUL	ュ
Y <sub>2</sub>	1	STX	7	1	P	.	J	U	7
	2	STX	7	1	NUL	>	NUL	NUL	'
	3	STX	7	1	セ	ル	マ	ナ	ヤ
	4	STX	7	1	NUL	。	NUL	NUL	ャ
Y <sub>3</sub>	1	ETX	8	2	{	,	H	Y	6
	2	ETX	8	2		<	NUL	NUL	&
	3	ETX	8	2	。	ネ	ク	ン	オ
	4	ETX	8	2	「	」	NUL	NUL	ォ
Y <sub>4</sub>	1	EOT	9	3	¥	M	G	T	5
	2	EOT	9	3		NUL	NUL	NUL	%
	3	EOT	9	3	—	モ	キ	カ	エ
	4	EOT	9	3	NUL	NUL	NUL	NUL	ェ
Y <sub>5</sub>	1	ENQ	NAK	4	BS	N	F	R	4
	2	ENQ	NAK	4	BS	NUL	NUL	NUL	\$
	3	ENQ	NAK	4	BS	ミ	ハ	ス	ウ
	4	ENQ	NAK	4	BS	NUL	NUL	NUL	ゥ
Y <sub>6</sub>	1	ACK	SYN	5	NUL	B	D	E	3
	2	ACK	SYN	5	—	NUL	NUL	NUL	#
	3	ACK	SYN	5	ロ	コ	シ	イ	ア
	4	ACK	SYN	5	NUL	NUL	NUL	NUL	ァ
Y <sub>7</sub>	1	BEL	ETB	+	}	V	S	W	2
	2	BEL	ETB	+		NUL	NUL	NUL	”
	3	BEL	ETB	+	△	ヒ	ト	テ	フ
	4	BEL	ETB	+	」	NUL	NUL	NUL	NUL
Y <sub>8</sub>	1	=	CAN	SP	CR	C	A	O	!
	2	=	CAN	SP	CR	NUL	NUL	NUL	!
	3	=	CAN	SP	CR	ソ	チ	タ	ヌ
	4	=	CAN	SP	CR	NUL	NUL	NUL	NUL
Y <sub>9</sub>	1	SO	EM	・	LF	X	FF	HT	@
	2	SO	EM	・	LF	NUL	FF	HT	、
	3	SO	EM	・	LF	サ	FF	HT	、
	4	SO	EM	・	LF	NUL	FF	HT	NUL
Y <sub>10</sub>	1	SI	SUB	—	DEL	Z	ESC	VT	:
	2	SI	SUB	—	DEL	NUL	ESC	VT	*
	3	SI	SUB	—	DEL	ツ	ESC	VT	ヶ
	4	SI	SUB	—	DEL	ッ	ESC	VT	NUL

9

SYMBOLGY

Symbol	Code name	Col/Row in code table	X/Y/Mode in code arrangement table
SP	Space	2 / 0	2/8/1~4
!	Exclamation mark	2 / 1	7/8/2
“	Quotation mark, umlaut	2 / 2	7/7/2
#	Number sign	2 / 3	7/6/2
\$	Dollar sign	2 / 4	7/5/2
%	Percentage	2 / 5	7/4/2
&	Ampersand	2 / 6	7/3/2
'	Apostrophe, acute accent	2 / 7	7/2/2
(	Left parenthesis	2 / 8	7/1/2
)	Right parenthesis	2 / 9	7/0/2
*	Asterisk, multiplication sign	2 / 10	7/10/2
+	Positive sign, plus sign	2 / 11	2/7/1~4, 4/0/2
,	Comma	2 / 12	4/3/1
-	Negative sign, subtraction sign	2 / 13	2/10/1~4, 3/1/1
.	Period	2 / 14	2/9/1~4, 4/2/1
/	Slash, virgule, division sign, per	2 / 15	4/1/1
:	Colon	3 / 10	7/10/1
;	Semicolon	3 / 11	4/0/1
<	Less than sign	3 / 12	4/3/2
=	Equal sign	3 / 13	0/8/1~4, 3/1/2
>	Greater than sign	3 / 14	4/2/2

Symbol	Code name	Col/Row in code table	X/Y/Mode in code arrangement table
?	Question mark	3 / 15	4/1/2
@	At mark	4 / 0	7/9/1
{	Left bracket	5 / 11	3/3/1
¥	Yen sign	5 / 12	3/4/1
}	Right bracket	5 / 13	3/7/1
^	Circumflex accent	5 / 14	2/0/1
_	Underline	5 / 15	3/6/2
`	Grave accent	6 / 0	7/9/2
{	Left brace	7 / 11	3/3/2
	Separate sign, logical add sign	7 / 12	3/4/2
}	Right brace	7 / 13	3/7/2
—	Overline, logical not sign	7 / 14	2/0/2
。	Japanese period	10 / 1	4/2/4
「	Japanese initial quotation mark	10 / 2	3/3/4
」	Japanese final quotation mark	10 / 3	3/7/4
、	Japanese comma	10 / 4	4/3/4
・	Middle dot	10 / 5	4/1/4
—	Long vowel mark	11 / 0	3/4/3
・	Voiced consonant mark	13 / 14	7/9/3
・	Semi-voiced consonant mark	13 / 15	3/3/3

**mitsubishi** LSIs  
**M58609-04P, S**

**KEYBOARD ENCODER (JIS CODE STANDARD PRODUCT)**

**ABSOLUTE MAXIMUM RATINGS**

Symbol	Parameter	Conditions	Limits	Unit
V <sub>GG</sub>	Supply voltage	With respect to V <sub>SS</sub>	0.3 ~ -20	V
V <sub>DD</sub>	Supply voltage		0.3 ~ -20	V
V <sub>I</sub>	Input voltage		0.3 ~ -20	V
T <sub>opr</sub>	Operating free-air temperature range		-20 ~ 75	°C
T <sub>stg</sub>	Storage temperature range		-40 ~ 125	°C

**RECOMMENDED OPERATING CONDITIONS** (T<sub>a</sub> = -20 ~ 75°C, unless otherwise noted)

Symbol	Parameter	Limits			Unit
		Min	Nom	Max	
V <sub>GG</sub>	Supply voltage	-11	-12	-13	V
V <sub>DD</sub>	Supply voltage		0		V
V <sub>SS</sub>	Supply voltage	4.5	5	5.5	V
V <sub>IH</sub>	High-level input voltage	V <sub>SS</sub> - 1			V
V <sub>IL</sub>	Low-level input voltage			0.8	V
f (φ)	Clock frequency	20	50	100	kHz
t <sub>D(STO)</sub>	Strobe delay time		1.5		ms
R <sub>OFF</sub>	Switch off resistance	10			MΩ
R <sub>ON</sub>	Switch on resistance			300	Ω

**ELECTRICAL CHARACTERISTICS** (T<sub>a</sub> = -20 ~ 75°C, V<sub>GG</sub> = -12 ± 1V, V<sub>SS</sub> = 5 ± 0.5V, V<sub>DD</sub> = 0V, unless otherwise noted)

Symbol	Parameter	Test conditions	Limits			Unit
			Min	Typ	Max	
V <sub>OH</sub> (B <sub>i</sub> , STO)	High-level output voltage. B <sub>1</sub> ~ B <sub>9</sub> and STO	I <sub>OH</sub> = -100 μA	V <sub>SS</sub> - 1			V
V <sub>OH</sub> (X <sub>i</sub> )	High-level output voltage. X <sub>0</sub> ~ X <sub>7</sub>	I <sub>OH</sub> = -100 μA	V <sub>SS</sub> - 1.3			V
V <sub>OL</sub> (B <sub>i</sub> , STO)	Low-level output voltage. B <sub>1</sub> ~ B <sub>9</sub> and STO	I <sub>OL</sub> = 1.6 mA			0.4	V
V <sub>OL</sub> (X <sub>i</sub> )	Low-level output voltage. X <sub>0</sub> ~ X <sub>7</sub>	I <sub>OL</sub> = 1 μA			-3	V
R <sub>i</sub>	Input resistance. S, C, DSI and PI	V <sub>I</sub> = -12V	1			MΩ
P <sub>d</sub>	Power dissipation	T <sub>a</sub> = 25°C		70	200	mW
C <sub>i</sub>	Input capacitance	V <sub>I</sub> = 0V, f = 1MHz, T <sub>a</sub> = 25°C			15	pF

Note 2 : Current flowing into an IC is positive; out is negative.

**TIMING DIAGRAM**

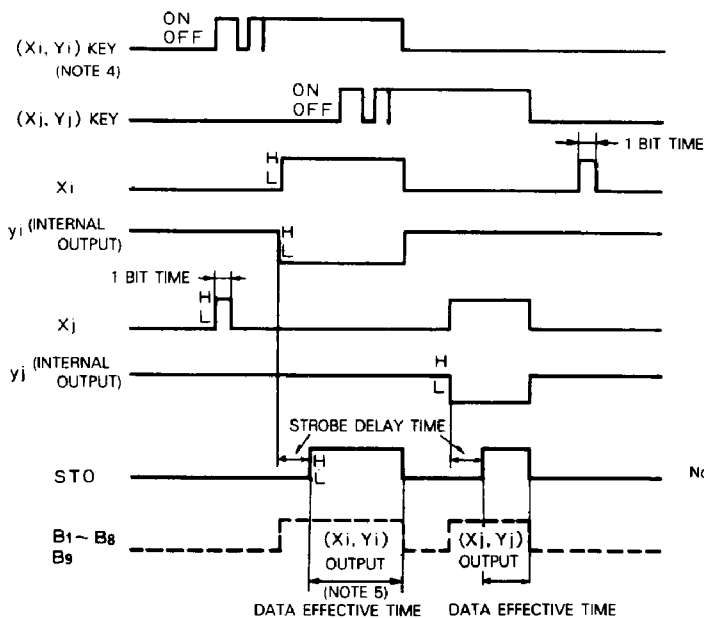

Note 3 : DSI = "L"

4 : (X<sub>i</sub>, Y<sub>i</sub>) KEY indicates the key switch that is located at the cross point of X<sub>i</sub> and Y<sub>i</sub> of the keyboard matrix.

5 : (X<sub>i</sub>, Y<sub>i</sub>) OUTPUT indicates the code output of the key that is selected by the (X<sub>i</sub>, Y<sub>i</sub>) KEY.

KEYBOARD ENCODER (JIS CODE STANDARD PRODUCT)

FUNCTION TABLES

Data (B <sub>1</sub> ~ B <sub>9</sub> ) Invert			Strobe (STO) Invert			Parity (B <sub>9</sub> ) Invert			Mode Select		
DSI (Pin 20)	Code table (B <sub>1</sub> ~ B <sub>9</sub> )	Data output (B <sub>1</sub> ~ B <sub>9</sub> )	DSI (Pin 20)	Internal strobe (Note 3)	STO (Pin 16)	P1 (Pin 6)	Code table (B <sub>9</sub> )	B <sub>9</sub> (Pin 7)	S (Pin 4)	C (Pin 5)	Mode
H	1	L	H	H	L	H	1	L	L	L	M <sub>1</sub>
L	1	H	L	H	H	L	1	H	H	L	M <sub>2</sub>
H	0	H	H	L	H	H	0	H	L	H	M <sub>3</sub>
L	0	L	L	L	L	L	0	L	H	H	M <sub>4</sub>

Note 6: The internal signal of the strobe output (STO) becomes high-level when the strobe signal is generated.

TYPICAL APPLICATION CIRCUIT

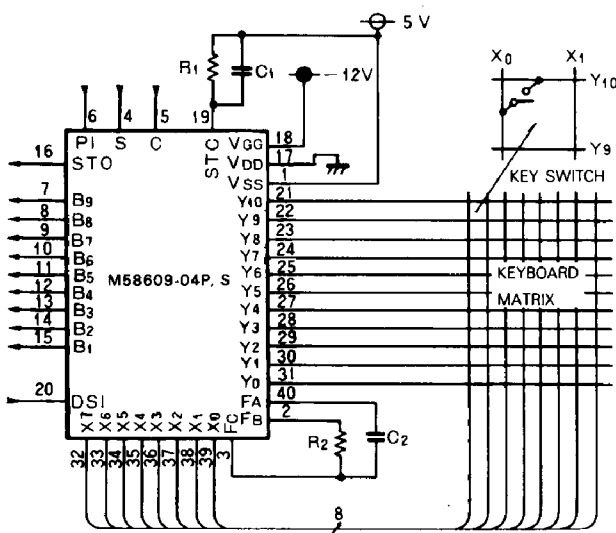

Note 7: R<sub>1</sub> = 1.5MΩ, C<sub>1</sub> = 0.001 μF provides approximately 1.5ms delay time.  
8: R<sub>2</sub> = 75kΩ, C<sub>2</sub> = 50pF provides approximately 50kHz clock frequency.

Fig. 1 Measures against coupling

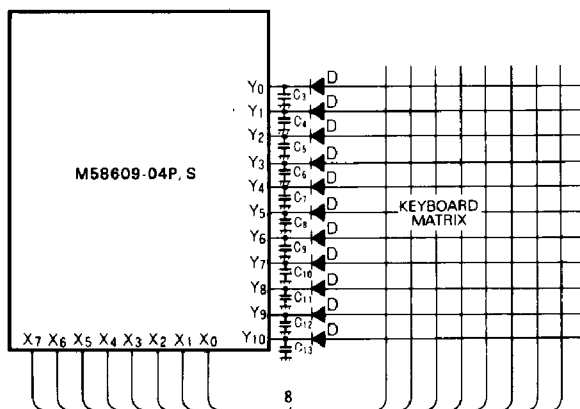

Insert diodes and capacitors (C<sub>3</sub> ~ C<sub>13</sub> should be approx. 50 ~ 100pF) between the keyboard matrix and the Y inputs.

Cautions in Use

1. Coupling at the Keyboard Matrix

Depending on the capacitance of the keyboard matrix wiring, depressing one key while another is depressed gives rise to capacitance coupling, which may result in repetition of the strobe output, the same condition that would occur if a single key were depressed twice. In this case, proceed as shown in Fig. 1.

2. N-Key Rollover

This device is for 2-key rollover; when 3 or more keys are depressed simultaneously, code output is indeterminate.

3. Maximum Chatter Times

1. With Key Off (t<sub>KOFF</sub>)

t<sub>KOFF</sub> is defined as the maximum time that, when a key is turned on but because of faulty contact, etc. the key input signal chatters, the chattering can be disregarded. This may vary according to ambient temperature, power supply conditions, etc., but is approximately 100ns.

2. With Key On (t<sub>KON</sub>)

Conversely, t<sub>KON</sub> is the maximum time that, when a key is turned off, but the input signal chatters, the chattering condition can be disregarded.

$$\begin{aligned} \text{when } t_{KOFF} \leq 1/f_{\phi} \quad t_{KON} &\leq 100\text{ns} \\ \text{when } t_{KOFF} > 1/f_{\phi} \quad t_{KON} &\leq t_{STD} + t_{SC} \\ \text{where: } f_{\phi} &= \text{clock frequency} \\ t_{STD} &= \text{strobe delay time} \\ t_{SC} &= \text{scanning time} \end{aligned}$$

Fig. 2 Timing diagram for maximum chatter time

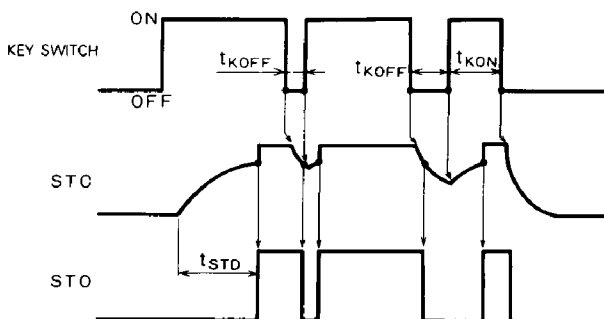

**MITSUBISHI LSI**  
**M58609-04P, S**

**KEYBOARD ENCODER (JIS CODE STANDARD PRODUCT)**

TYPICAL CHARACTERISTICS ( $V_{GG} = -12V$ ,  $V_{DD} = 0V$ ,  $V_{SS} = 5V$ )

