



Details are subject to change without notice.

## ONE-CELL LI-ION BATTERY PROTECTION IC

### FEATURES

- Ideal for One-Cell Rechargeable Li-Ion Battery Packs
- High Accuracy Voltage Detection
- Low Current Consumption:  
3 $\mu$ A Supply Current (Typical)  
0.1 $\mu$ A Shutdown Current
- 3-Level Over Current Detection:  
Over-Current Level 1 /Over Current Level 2 / Short Circuit
- Wide Operating Temperature Range:  
-40 $^{\circ}$ C to +85 $^{\circ}$ C
- Small SOT26 Package

### GENERAL DESCRIPTION

The AAT8660 series are designed to protect one-cell rechargeable Li-Ion battery pack against over-charge, over-discharge, over-current and short circuit. They use CMOS process to provide high accuracy voltage detection and low current consumption.

Each of the AAT8660 devices incorporates voltage comparators, bandgap reference voltage generator, signal delay circuit, short circuit detector, and digital control circuit.

In the charge process, when the battery voltage is charged to a value greater than  $V_{C1}$  (Over-Charge Threshold Voltage), the output of  $C_{out}$  pin switches to the low level, i.e., the  $V_N$  pin level. The output of  $C_{out}$  pin will switch to high level when the battery voltage falls lower than  $V_{C2}$  (Over-Charge Release Voltage), or when the charger is disconnected from the battery pack and the battery voltage level ranges between  $V_{C1}$  and  $V_{C2}$ .

During the discharge process, when the battery voltage drops to a value lower than  $V_{D1}$  (Over-Discharge Threshold Voltage), the output of  $D_{out}$  pin switches to low level immediately after the internal delay time elapses. The output of  $D_{out}$  pin will switch to high level when the battery voltage is at a level higher than  $V_{D2}$  (Over-Discharge Release Voltage).

### PIN CONFIGURATION

TOP VIEW

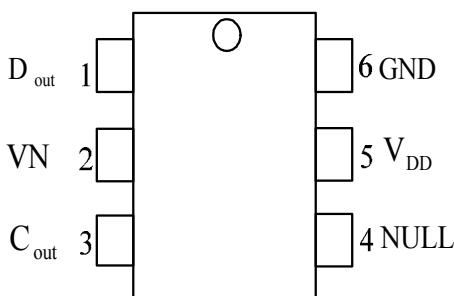

(SOT26)



Over current level 1 voltage ( $V_{OC1}$ ) is used to monitor the amount of discharge current. If the discharge current is high enough to cause VN pin voltage increase to a value greater than  $V_{OC1}$ , the output of  $D_{out}$  pin will switch to a low level after a delay time  $t_{OC1}$ . If the load is removed from battery pack, the output of  $D_{out}$  will change to a high level again.

identical to a discharge current. If the short circuit current is high enough to cause VN pin voltage increase to greater than  $V_{short}$ , the output of  $D_{out}$  pin will move to the low level after a delay time  $t_{short}$ , and the output of  $D_{out}$  level will change to high when the load is removed from battery pack.

The mechanism of short circuit protection is

**BLOCK DIAGRAM:**

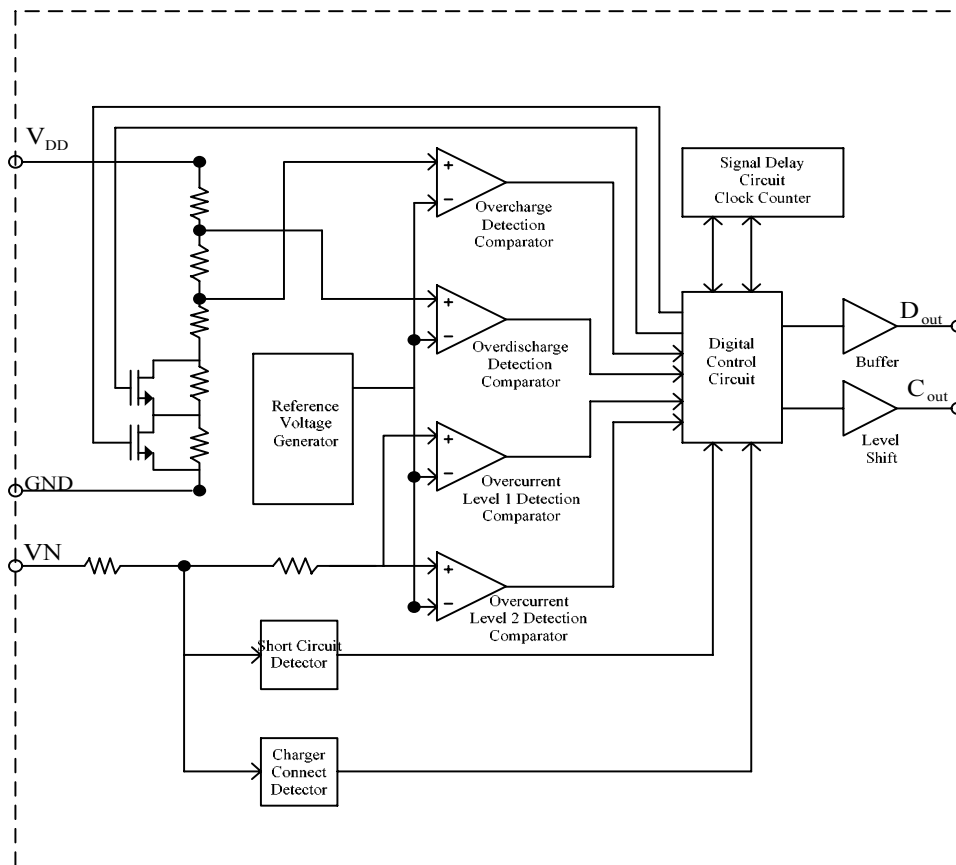



**PIN DESCRIPTION**

PIN NO	NAME	I/O	DESCRIPTION
1	D <sub>out</sub>	O	Discharge Control Pin which Connects to External MOSFET Gate
2	VN	I	Voltage Detection Pin between VN and GND
3	C <sub>out</sub>	O	Charge Control Pin which Connects to External MOSFET Gate.
4	NULL		Null Pad.
5	V <sub>DD</sub>	I	Power Supply Input Pin
6	GND	I	Ground

**ABSOLUTE MAXIMUM RATINGS**

CHARACTERISTICS	SYMBOL	VALUE	UNIT
Supply Voltage	V <sub>DD</sub>	-0.3 to 8.0	V
VN Pin Input Voltage	V <sub>VN</sub>	V <sub>DD</sub> - 20 to V <sub>DD</sub> + 0.3	V
D <sub>out</sub> Pin Output Voltage	V <sub>Dout</sub>	-0.3 to V <sub>DD</sub> + 0.3	V
C <sub>out</sub> Pin Output Voltage	V <sub>Cout</sub>	V <sub>VN</sub> - 0.3 to V <sub>DD</sub> + 0.3	V
Power Dissipation	P <sub>d</sub>	150	mW
Operating Temperature Range	T <sub>C</sub>	-40 to +85	°C
Storage Temperature Range	T <sub>storage</sub>	-40 to +125	°C

**RECOMMENDED OPERATING CONDITIONS**

	TEST CONDITION	MIN	MAX	UNIT
Supply Voltage, V <sub>DD</sub>	Voltage Defined as V <sub>DD</sub> to GND	1.5	7.0	V
D <sub>out</sub> Output Voltage		GND	V <sub>DD</sub>	V
C <sub>out</sub> Output Voltage		VN	V <sub>DD</sub>	V

**OPERATION VOLTAGE AND OPERATION CURRENT**

PARAMETER	TEST CONDITION	MIN	TYP	MAX	UNIT
Supply Current at Normal Operation Mode	V <sub>DD</sub> =3.3V; VN=0V; GND=0V		3.0	6.0	μA
Standby Current at Power Down Mode		-	-	0.1	μA
Operation Voltage between V <sub>DD</sub> and VN		1.5		20.0	V



**AAT8660A DETECTION VOLTAGE AND DELAY TIME (25° C)**

PARAMETER	SYMBOL	TEST CONDITION	MIN	TYP	MAX	UNIT
Over Charge Threshold Voltage	$V_{C1}$	Detect Rising Edge of Supply Voltage	4.275	4.325	4.375	V
Over Charge Release Voltage	$V_{C2}$	Detect Falling Edge of Supply Voltage	$V_{C1}-0.35$	$V_{C1}-0.25$	$V_{C1}-0.15$	V
Over Discharge Threshold Voltage	$V_{D1}$	Detect Falling Edge of Supply Voltage	2.420	2.500	2.580	V
Over Discharge Release Voltage	$V_{D2}$	Detect Rising Edge of Supply Voltage	$V_{D1}+0.3$	$V_{D1}+0.4$	$V_{D1}+0.5$	V
Over Charge Delay Time	$t_{C1}$	$V_{DD} = 3.6V$ to $4.5V$	0.700	1.000	1.300	s
Over Discharge Delay Time	$t_{D1}$	$V_{DD} = 3.6V$ to $2.4V$	87.5	125.0	162.5	ms
Over Current Level 1 Detection Voltage	$V_{OC1}$	Detect Rising Edge of “VN” Pin Voltage ( $D_{out}$ Response with $t_{OC1}$ Delay Time)	130	150	170	mV
Over Current Level 2 Detection Voltage	$V_{OC2}$	Detect Rising Edge of “VN” Pin Voltage ( $D_{out}$ Response with $t_{OC2}$ Delay Time)	400	500	600	mV
Short Circuit Detection Voltage	$V_{short}$	$V_{DD} = 3.0V$ , Detect Rising Edge of “VN” Pin Voltage ( $D_{out}$ Response with $t_{short}$ Delay Time)	$V_{DD}-1.7$	$V_{DD}-1.3$	$V_{DD}-0.9$	V
Over Current Level 1 Detection Delay Time	$t_{OC1}$	$V_{DD} = 3.0V$	5.6	8.0	10.4	ms
Over Current Level 2 Detection Delay Time	$t_{OC2}$	Room Temp. $\Rightarrow$ Low or High Temp. $\Rightarrow$ $V_{DD} = 3.0V$	1.4 1.1	2.0 2.0	2.6 3.4	ms ms
Short Circuit Detection Delay Time	$t_{short}$	$V_{DD} = 3.0V$		10	50	$\mu$ s
Charger Detection Voltage	$V_{CHR}$	Detect Rising Edge of “ $D_{out}$ ” Pin Voltage (when $V_{D1} < V_{DD} < V_{D2}$ )	-2.0	-1.3	-0.6	V
$C_{out}$ High Level Resistance	$R_{COH}$	$V_{DD} = 3.5V$ ; $C_{out} = 3.0V$ ; $VN = 0V$	1	2	10	k $\Omega$
$C_{out}$ Low Level Resistance	$R_{COL}$	$V_{DD} = 4.5V$ ; $C_{out} = 0.5V$ ; $VN = 0V$	150	602	2,380	k $\Omega$
$D_{out}$ High Level Resistance	$R_{DOH}$	$V_{DD} = 3.5V$ ; $D_{out} = 3.0V$ ; $VN = 0V$	2.5	5.0	10.0	k $\Omega$
$D_{out}$ Low Level Resistance	$R_{DOL}$	$V_{DD} = 1.8V$ ; $D_{out} = 0.5V$ ; $VN = 1.8V$	2.5	5.0	10.0	k $\Omega$
Internal Resistance between VN and $V_{DD}$	$R_{VND}$	$V_{DD} = 1.8V$ ; $VN = 0V$	100	300	900	k $\Omega$
Internal Resistance between VN and GND	$R_{VNG}$	$V_{DD} = 3.5V$ ; $VN = 3.5V$	10	20	40	k $\Omega$



**AAT8660B DETECTION VOLTAGE AND DELAY TIME (25 )**

PARAMETER	SYMBOL	TEST CONDITION	MIN	TYP	MAX	UNIT
Over Charge Threshold Voltage	$V_{C1}$	Detect Rising Edge of Supply Voltage	4.300	4.350	4.400	V
Over Charge Release Voltage	$V_{C2}$	Detect Falling Edge of Supply Voltage	$V_{C1}-0.30$	$V_{C1}-0.20$	$V_{C1}-0.10$	V
Over Discharge Threshold Voltage	$V_{D1}$	Detect Falling Edge of Supply Voltage	2.220	2.300	2.380	V
Over Discharge Release Voltage	$V_{D2}$	Detect Rising Edge of Supply Voltage	$V_{D1}+0.6$	$V_{D1}+0.7$	$V_{D1}+0.8$	V
Over Charge Delay Time	$t_{C1}$	$V_{DD} = 3.6V$ to $4.5V$	0.088	0.125	0.163	s
Over Discharge Delay Time	$t_{D1}$	$V_{DD} = 3.6V$ to $2.4V$	22.4	32.0	41.6	ms
Over Current Level 1 Detection Voltage	$V_{OC1}$	Detect Rising Edge of “VN” Pin Voltage ( $D_{out}$ Response with $t_{OC1}$ Delay Time)	130	150	170	mV
Over Current Level 2 Detection Voltage	$V_{OC2}$	Detect Rising Edge of “VN” Pin Voltage ( $D_{out}$ Response with $t_{OC2}$ Delay Time)	400	500	600	mV
Short Circuit Detection Voltage	$V_{short}$	$V_{DD} = 3.0V$ , Detect Rising Edge of “VN” Pin Voltage ( $D_{out}$ Response with $t_{short}$ Delay Time)	$V_{DD}-1.7$	$V_{DD}-1.3$	$V_{DD}-0.9$	V
Over Current Level 1 Detection Delay Time	$t_{OC1}$	$V_{DD} = 3.0V$	2.8	4.0	5.2	ms
Over Current Level 2 Detection Delay Time	$t_{OC2}$	Room Temp. $\Rightarrow$ Low or High Temp. $\Rightarrow$ $V_{DD} = 3.0V$	1.4 1.1	2.0 2.0	2.6 3.4	ms ms
Short Circuit Detection Delay Time	$t_{short}$	$V_{DD} = 3.0V$		10	50	$\mu$ s
Charger Detection Voltage	$V_{CHR}$	Detect Rising Edge of “ $D_{out}$ ” Pin Voltage (when $V_{D1} < V_{DD} < V_{D2}$ )	-2.0	-1.3	-0.6	V
$C_{out}$ High Level Resistance	$R_{COH}$	$V_{DD} = 3.5V$ ; $C_{OUT} = 3.0V$ ; $VN = 0V$	1	2	10	k $\Omega$
$C_{out}$ Low Level Resistance	$R_{COL}$	$V_{DD} = 4.5V$ ; $C_{OUT} = 0.5V$ ; $VN = 0V$	150	602	2,380	k $\Omega$
$D_{out}$ High Level Resistance	$R_{DOH}$	$V_{DD} = 3.5V$ ; $D_{out} = 3.0V$ ; $VN = 0V$	2.5	5.0	10.0	k $\Omega$
$D_{out}$ Low Level Resistance	$R_{DOL}$	$V_{DD} = 1.8V$ ; $D_{out} = 0.5V$ ; $VN = 1.8V$	2.5	5.0	10.0	k $\Omega$
Internal Resistance between VN and $V_{DD}$	$R_{VND}$	$V_{DD} = 1.8V$ ; $VN = 0V$	100	300	900	k $\Omega$
Internal Resistance between VN and GND	$R_{VNG}$	$V_{DD} = 3.5V$ ; $VN = 3.5V$	10	20	40	k $\Omega$



**AAT8660C DETECTION VOLTAGE AND DELAY TIME (25 )**

PARAMETER	SYMBOL	TEST CONDITION	MIN	TYP	MAX	UNIT
Over Charge Threshold Voltage	$V_{C1}$	Detect Rising Edge of Supply Voltage	4.250	4.300	4.350	V
Over Charge Release Voltage	$V_{C2}$	Detect Falling Edge of Supply Voltage	$V_{C1}-0.30$	$V_{C1}-0.20$	$V_{C1}-0.10$	V
Over Discharge Threshold Voltage	$V_{D1}$	Detect Falling Edge of Supply Voltage	2.220	2.300	2.380	V
Over Discharge Release Voltage	$V_{D2}$	Detect Rising Edge of Supply Voltage	$V_{D1}-0.08$	$V_{D1}$	$V_{D1}+0.08$	V
Over Charge Delay Time	$t_{C1}$	$V_{DD} = 3.6V$ to $4.5V$	0.700	1.000	1.300	s
Over Discharge Delay Time	$t_{D1}$	$V_{DD} = 3.6V$ to $2.4V$	87.5	125.0	162.5	ms
Over Current Level 1 Detection Voltage	$V_{OC1}$	Detect Rising Edge of “VN” Pin Voltage ( $D_{out}$ Response with $t_{OC1}$ Delay Time)	80	100	120	mV
Over Current Level 2 Detection Voltage	$V_{OC2}$	Detect Rising Edge of “VN” Pin Voltage ( $D_{out}$ Response with $t_{OC2}$ Delay Time)	400	480	600	mV
Short Circuit Detection Voltage	$V_{short}$	$V_{DD} = 3.0V$ , Detect Rising Edge of “VN” Pin Voltage ( $D_{out}$ Response with $t_{short}$ Delay Time)	$V_{DD}-1.7$	$V_{DD}-1.3$	$V_{DD}-0.9$	V
Over Current Level 1 Detection Delay Time	$t_{OC1}$	$V_{DD} = 3.0V$	5.6	8.0	10.4	ms
Over Current Level 2 Detection Delay Time	$t_{OC2}$	Room Temp. $\Rightarrow$ Low or High Temp. $\Rightarrow$ $V_{DD} = 3.0V$	1.4 1.1	2.0 2.0	2.6 3.4	ms ms
Short Circuit Detection Delay Time	$t_{short}$	$V_{DD} = 3.0V$		10	50	$\mu$ S
Charger Detection Voltage	$V_{CHR}$	Detect Rising Edge of “ $D_{out}$ ” Pin Voltage (when $V_{D1} < V_{DD} < V_{D2}$ )	-2.0	-1.3	-0.6	V
$C_{out}$ High Level Resistance	$R_{COH}$	$V_{DD} = 3.5V$ ; $C_{out} = 3.0V$ ; $VN = 0V$	1	2	10	k $\Omega$
$C_{out}$ Low Level Resistance	$R_{COL}$	$V_{DD} = 4.5V$ ; $C_{out} = 0.5V$ ; $VN = 0V$	150	602	2,380	k $\Omega$
$D_{out}$ High Level Resistance	$R_{DOH}$	$V_{DD} = 3.5V$ ; $D_{out} = 3.0V$ ; $VN = 0V$	2.5	5.0	10.0	k $\Omega$
$D_{out}$ Low Level Resistance	$R_{DOL}$	$V_{DD} = 1.8V$ ; $D_{out} = 0.5V$ ; $VN = 1.8V$	2.5	5.0	10.0	k $\Omega$
Internal Resistance between VN and $V_{DD}$	$R_{VND}$	$V_{DD} = 1.8V$ ; $VN = 0V$	100	300	900	k $\Omega$
Internal Resistance between VN and GND	$R_{VNG}$	$V_{DD} = 3.5V$ ; $VN = 3.5V$	10	20	40	k $\Omega$



**AAT8660D DETECTION VOLTAGE AND DELAY TIME (25 )**

PARAMETER	SYMBOL	TEST CONDITION	MIN	TYP	MAX	UNIT
Over Charge Threshold Voltage	$V_{C1}$	Detect Rising Edge of Supply Voltage	4.230	4.280	4.330	V
Over Charge Release Voltage	$V_{C2}$	Detect Falling Edge of Supply Voltage	$V_{C1}-0.30$	$V_{C1}-0.20$	$V_{C1}-0.10$	V
Over Discharge Threshold Voltage	$V_{D1}$	Detect Falling Edge of Supply Voltage	2.201	2.281	2.361	V
Over Discharge Release Voltage	$V_{D2}$	Detect Rising Edge of Supply Voltage	$V_{D1}-0.08$	$V_{D1}$	$V_{D1}+0.08$	V
Over Charge Delay Time	$t_{C1}$	$V_{DD} = 3.6V$ to $4.5V$	0.700	1.000	1.300	s
Over Discharge Delay Time	$t_{D1}$	$V_{DD} = 3.6V$ to $2.4V$	87.5	125.0	162.5	ms
Over Current Level 1 Detection Voltage	$V_{OC1}$	Detect Rising Edge of “VN” Pin Voltage ( $D_{out}$ Response With $t_{OC1}$ Delay Time)	110	130	150	mV
Over Current Level 2 Detection Voltage	$V_{OC2}$	Detect Rising Edge of “VN” Pin Voltage ( $D_{out}$ Response with $t_{OC2}$ Delay Time)	400	490	600	mV
Short Circuit Detection Voltage	$V_{short}$	$V_{DD} = 3.0V$ , Detect Rising Edge of “VN” Pin Voltage ( $D_{out}$ Response with $t_{short}$ Delay Time)	$V_{DD}-1.7$	$V_{DD}-1.3$	$V_{DD}-0.9$	V
Over Current Level 1 Detection Delay Time	$t_{OC1}$	$V_{DD} = 3.0V$	5.6	8.0	10.4	ms
Over Current Level 2 Detection Delay Time	$t_{OC2}$	Room Temp. $\Rightarrow$ Low or High Temp. $\Rightarrow$ $V_{DD} = 3.0V$	1.4 1.1	2.0 2.0	2.6 3.4	ms ms
Short Circuit Detection Delay Time	$t_{short}$	$V_{DD} = 3.0V$		10	50	$\mu$ s
Charger Detection Voltage	$V_{CHR}$	Detect Rising Edge of “ $D_{out}$ ” Pin Voltage (when $V_{D1} < V_{DD} < V_{D2}$ )	-2.0	-1.3	-0.6	V
$C_{out}$ High Level Resistance	$R_{COH}$	$V_{DD} = 3.5V$ ; $C_{out} = 3.0V$ ; $VN = 0V$	1	2	10	k $\Omega$
$C_{out}$ Low Level Resistance	$R_{COL}$	$V_{DD} = 4.5V$ ; $C_{out} = 0.5V$ ; $VN = 0V$	150	602	2,380	k $\Omega$
$D_{out}$ High Level Resistance	$R_{DOH}$	$V_{DD} = 3.5V$ ; $D_{out} = 3.0V$ ; $VN = 0V$	2.5	5.0	10.0	k $\Omega$
$D_{out}$ Low Level Resistance	$R_{DOL}$	$V_{DD} = 1.8V$ ; $D_{out} = 0.5V$ ; $VN = 1.8V$	2.5	5.0	10.0	k $\Omega$
Internal Resistance between VN and $V_{DD}$	$R_{VND}$	$V_{DD} = 1.8V$ ; $VN=0V$	100	300	900	k $\Omega$
Internal Resistance between VN and GND	$R_{VNG}$	$V_{DD} = 3.5V$ ; $VN = 3.5V$	10	20	40	k $\Omega$



**AAT8660E DETECTION VOLTAGE AND DELAY TIME (25 )**

PARAMETER	SYMBOL	TEST CONDITION	MIN	TYP	MAX	UNIT
Over Charge Threshold Voltage	$V_{C1}$	Detect Rising Edge of Supply Voltage	4.230	4.280	4.330	V
Over Charge Release Voltage	$V_{C2}$	Detect Falling Edge of Supply Voltage	$V_{C1}-0.30$	$V_{C1}-0.20$	$V_{C1}-0.10$	V
Over Discharge Threshold Voltage	$V_{D1}$	Detect Falling Edge of Supply Voltage	2.201	2.281	2.361	V
Over Discharge Release Voltage	$V_{D2}$	Detect Rising Edge of Supply Voltage	$V_{D1}+0.5$	$V_{D1}+0.6$	$V_{D1}+0.7$	V
Over Charge Delay Time	$t_{C1}$	$V_{DD} = 3.6V$ to $4.5V$	0.700	1.000	1.300	s
Over Discharge Delay Time	$t_{D1}$	$V_{DD} = 3.6V$ to $2.4V$	87.5	125.0	162.5	ms
Over Current Level 1 Detection Voltage	$V_{OC1}$	Detect Rising Edge of “VN” Pin Voltage ( $D_{out}$ Response with $t_{OC1}$ Delay Time)	80	100	120	mV
Over Current Level 2 Detection Voltage	$V_{OC2}$	Detect Rising Edge of “VN” Pin Voltage ( $D_{out}$ Response with $t_{OC2}$ Delay Time)	400	480	600	mV
Short Circuit Detection Voltage	$V_{short}$	$V_{DD} = 3.0V$ , Detect Rising Edge of “VN” Pin Voltage ( $D_{out}$ Response with $t_{short}$ Delay Time)	$V_{DD}-1.7$	$V_{DD}-1.3$	$V_{DD}-0.9$	V
Over Current Level 1 Detection Delay Time	$t_{OC1}$	$V_{DD} = 3.0V$	5.6	8.0	10.4	ms
Over Current Level 2 Detection Delay Time	$t_{OC2}$	Room Temp. $\Rightarrow$ Low or High Temp. $\Rightarrow$ $V_{DD} = 3.0V$	1.4 1.1	2.0 2.0	2.6 3.4	ms ms
Short Circuit Detection Delay Time	$t_{short}$	$V_{DD} = 3.0V$		10	50	$\mu$ s
Charger Detection Voltage	$V_{CHR}$	Detect Rising Edge of “ $D_{out}$ ” Pin Voltage (when $V_{D1} < V_{DD} < V_{D2}$ )	-2.0	-1.3	-0.6	V
$C_{out}$ High Level Resistance	$R_{COH}$	$V_{DD} = 3.5V$ ; $C_{out} = 3.0V$ ; $VN = 0V$	1	2	10	k $\Omega$
$C_{out}$ Low Level Resistance	$R_{COL}$	$V_{DD} = 4.5V$ ; $C_{out} = 0.5V$ ; $VN = 0V$	150	602	2,380	k $\Omega$
$D_{out}$ High Level Resistance	$R_{DOH}$	$V_{DD} = 3.5V$ ; $D_{out} = 3.0V$ ; $VN = 0V$	2.5	5.0	10.0	k $\Omega$
$D_{out}$ Low Level Resistance	$R_{DOL}$	$V_{DD} = 1.8V$ ; $D_{out} = 0.5V$ ; $VN = 1.8V$	2.5	5.0	10.0	k $\Omega$
Internal Resistance between VN and $V_{DD}$	$R_{VND}$	$V_{DD} = 1.8V$ ; $VN = 0V$	100	300	900	k $\Omega$
Internal Resistance between VN and GND	$R_{VNG}$	$V_{DD} = 3.5V$ ; $VN = 3.5V$	10	20	40	k $\Omega$





**AAT8660F DETECTION VOLTAGE AND DELAY TIME (25 )**

PARAMETER	SYMBOL	TEST CONDITION	MIN	TYP	MAX	UNIT
Over Charge Threshold Voltage	$V_{C1}$	Detect Rising Edge of Supply Voltage	4.275	4.325	4.375	V
Over Charge Release Voltage	$V_{C2}$	Detect Falling Edge of Supply Voltage	$V_{C1}-0.35$	$V_{C1}-0.25$	$V_{C1}-0.15$	V
Over Discharge Threshold Voltage	$V_{D1}$	Detect Falling Edge of Supply Voltage	2.420	2.500	2.580	V
Over Discharge Release Voltage	$V_{D2}$	Detect Rising Edge of Supply Voltage	$V_{D1}+0.3$	$V_{D1}+0.4$	$V_{D1}+0.5$	V
Over Charge Delay Time	$t_{C1}$	$V_{DD} = 3.6V$ to $4.5V$	0.700	1.000	1.300	s
Over Discharge Delay Time	$t_{D1}$	$V_{DD} = 3.6V$ to $2.4V$	87.5	125.0	162.5	ms
Over Current Level 1 Detection Voltage	$V_{OC1}$	Detect Rising Edge of “VN” Pin Voltage ( $D_{out}$ Response with $t_{OC1}$ Delay Time)	80	100	120	mV
Over Current Level 2 Detection Voltage	$V_{OC2}$	Detect Rising Edge of “VN” Pin Voltage ( $D_{out}$ Response with $t_{OC2}$ Delay Time)	400	480	600	mV
Short Circuit Detection Voltage	$V_{short}$	$V_{DD} = 3.0V$ , Detect Rising Edge of “VN” Pin Voltage ( $D_{out}$ Response with $t_{short}$ Delay Time)	$V_{DD}-1.7$	$V_{DD}-1.3$	$V_{DD}-0.9$	V
Over Current Level 1 Detection Delay Time	$t_{OC1}$	$V_{DD} = 3.0V$	5.6	8.0	10.4	ms
Over Current Level 2 Detection Delay Time	$t_{OC2}$	Room Temp. $\Rightarrow$ Low or High Temp. $\Rightarrow$ $V_{DD} = 3.0V$	1.4 1.1	2.0 2.0	2.6 3.4	ms ms
Short Circuit Detection Delay Time	$t_{short}$	$V_{DD} = 3.0V$		10	50	$\mu$ s
Charger Detection Voltage	$V_{CHR}$	Detect Rising Edge of “ $D_{out}$ ” Pin Voltage (When $V_{D1} < V_{DD} < V_{D2}$ )	-2.0	-1.3	-0.6	V
$C_{out}$ High Level Resistance	$R_{COH}$	$V_{DD} = 3.5V$ ; $C_{out} = 3.0V$ ; $VN = 0V$	1	2	10	k $\Omega$
$C_{out}$ Low Level Resistance	$R_{COL}$	$V_{DD} = 4.5V$ ; $C_{out} = 0.5V$ ; $VN = 0V$	150	602	2,380	k $\Omega$
$D_{out}$ High Level Resistance	$R_{DOH}$	$V_{DD} = 3.5V$ ; $D_{out} = 3.0V$ ; $VN=0V$	2.5	5.0	10.0	k $\Omega$
$D_{out}$ Low Level Resistance	$R_{DOL}$	$V_{DD} = 1.8V$ ; $D_{out} = 0.5V$ ; $VN=1.8V$	2.5	5.0	10.0	k $\Omega$
Internal Resistance between VN and $V_{DD}$	$R_{VND}$	$V_{DD} = 1.8V$ ; $VN = 0V$	100	300	900	k $\Omega$
Internal Resistance between VN and GND	$R_{VNG}$	$V_{DD} = 3.5V$ ; $VN=3.5V$	10	20	40	k $\Omega$



**AAT8660G DETECTION VOLTAGE AND DELAY TIME (25 )**

PARAMETER	SYMBOL	TEST CONDITION	MIN	TYP	MAX	UNIT
Over Charge Threshold Voltage	$V_{C1}$	Detect Rising Edge of Supply Voltage	4.300	4.350	4.400	V
Over Charge Release Voltage	$V_{C2}$	Detect Falling Edge of Supply Voltage	$V_{C1}-0.30$	$V_{C1}-0.20$	$V_{C1}-0.10$	V
Over Discharge Threshold Voltage	$V_{D1}$	Detect Falling Edge of Supply Voltage	2.220	2.300	2.380	V
Over Discharge Release Voltage	$V_{D2}$	Detect Rising Edge of Supply Voltage	$V_{D1}+0.6$	$V_{D1}+0.7$	$V_{D1}+0.8$	V
Over Charge Delay Time	$t_{C1}$	$V_{DD} = 3.6V$ to $4.5V$	0.088	0.125	0.163	s
Over Discharge Delay Time	$t_{D1}$	$V_{DD} = 3.6V$ to $2.4V$	22.4	32.0	41.6	ms
Over Current Level 1 Detection Voltage	$V_{OC1}$	Detect Rising Edge of “VN” Pin Voltage ( $D_{out}$ Response with $t_{OC1}$ Delay Time)	180	200	220	mV
Over Current Level 2 Detection Voltage	$V_{OC2}$	Detect Rising Edge of “VN” Pin Voltage ( $D_{out}$ Response with $t_{OC2}$ Delay Time)	400	510	600	mV
Short Circuit Detection Voltage	$V_{short}$	$V_{DD} = 3.0V$ , Detect Rising Edge of “VN” Pin Voltage ( $D_{out}$ Response with $t_{short}$ Delay Time)	$V_{DD}-1.7$	$V_{DD}-1.3$	$V_{DD}-0.9$	V
Over Current Level 1 Detection Delay Time	$t_{OC1}$	$V_{DD} = 3.0V$	2.8	4	5.2	ms
Over Current Level 2 Detection Delay Time	$t_{OC2}$	Room Temp. $\Rightarrow$ Low or High Temp. $\Rightarrow$ $V_{DD} = 3.0V$	1.4 1.1	2.0 2.0	2.6 3.4	ms ms
Short Circuit Detection Delay Time	$t_{short}$	$V_{DD} = 3.0V$		10	50	$\mu$ s
Charger Detection Voltage	$V_{CHR}$	Detect Rising Edge of “ $D_{out}$ ” Pin Voltage (when $V_{D1} < V_{DD} < V_{D2}$ )	-2.0	-1.3	-0.6	V
$C_{out}$ High Resistance Level	$R_{COH}$	$V_{DD} = 3.5V$ ; $C_{out} = 3.0V$ ; VN=0V	1	2	10	k $\Omega$
$C_{out}$ Low Resistance Level	$R_{COL}$	$V_{DD} = 4.5V$ ; $C_{out} = 0.5V$ ; VN=0V	150	602	2,380	k $\Omega$
$D_{out}$ High Resistance Level	$R_{DOH}$	$V_{DD} = 3.5V$ ; $D_{out} = 3.0V$ ; VN=0V	2.5	5.0	10.0	k $\Omega$
$D_{out}$ Low Resistance Level	$R_{DOL}$	$V_{DD} = 1.8V$ ; $D_{out} = 0.5V$ ; VN=1.8V	2.5	5.0	10.0	k $\Omega$
Internal Resistance between VN and $V_{DD}$	$R_{VND}$	$V_{DD} = 1.8V$ ; VN=0V	100	300	900	k $\Omega$
Internal Resistance between VN and GND	$R_{VNG}$	$V_{DD} = 3.5V$ ; VN=3.5V	10	20	40	k $\Omega$



**AAT8660H DETECTION VOLTAGE AND DELAY TIME (25 )**

PARAMETER	SYMBOL	TEST CONDITION	MIN	TYP	MAX	UNIT
Over Charge Threshold Voltage	$V_{C1}$	Detect Rising Edge of Supply Voltage	4.250	4.300	4.350	V
Over Charge Release Voltage	$V_{C2}$	Detect Falling Edge of Supply Voltage	$V_{C1}-0.30$	$V_{C1}-0.20$	$V_{C1}-0.10$	V
Over Discharge Threshold Voltage	$V_{D1}$	Detect Falling Edge of Supply Voltage	2.220	2.300	2.380	V
Over Discharge Release Voltage	$V_{D2}$	Detect rising Edge of Supply Voltage	$V_{D1}-0.08$	$V_{D1}$	$V_{D1}+0.08$	V
Over Charge Delay Time	$t_{C1}$	$V_{DD} = 3.6V$ to $4.5V$	0.700	1.000	1.300	s
Over Discharge Delay Time	$t_{D1}$	$V_{DD} = 3.6V$ to $2.4V$	87.5	125.0	162.5	ms
Over Current Level 1 Detection Voltage	$V_{OC1}$	Detect Rising Edge of “VN” Pin Voltage ( $D_{out}$ Response with $t_{OC1}$ Delay time)	130	150	170	mV
Over Current Level 2 Detection Voltage	$V_{OC2}$	Detect rising Edge of “VN” Pin Voltage ( $D_{out}$ Response With $t_{OC2}$ Delay Time)	400	500	600	mV
Short Circuit Detection Voltage	$V_{short}$	$V_{DD} = 3.0V$ , Detect Rising Edge of “VN” Pin Voltage ( $D_{out}$ Response with $t_{short}$ Delay Time)	$V_{DD}-1.7$	$V_{DD}-1.3$	$V_{DD}-0.9$	V
Over Current Level 1 Detection Delay Time	$t_{OC1}$	$V_{DD} = 3.0V$	5.6	8.0	10.4	ms
Over Current Level 2 Detection Delay Time	$t_{OC2}$	Room Temp. $\Rightarrow$ Low or High Temp. $\Rightarrow$ $V_{DD} = 3.0V$	1.4 1.1	2.0 2.0	2.6 3.4	ms ms
Short Circuit Detection Delay Time	$t_{short}$	$V_{DD} = 3.0V$		10	50	$\mu$ s
Charger Detection Voltage	$V_{CHR}$	Detect Rising Edge of “ $D_{out}$ ” Pin Voltage (when $V_{D1} < V_{DD} < V_{D2}$ )	-2.0	-1.3	-0.6	V
$C_{out}$ High Resistance Level	$R_{COH}$	$V_{DD} = 3.5V$ ; $C_{out} = 3.0V$ ;VN=0V	1	2	10	k $\Omega$
$C_{out}$ Low Resistance Level	$R_{COL}$	$V_{DD} = 4.5V$ ; $C_{out} = 0.5V$ ;VN=0V	150	602	2,380	k $\Omega$
$D_{out}$ High Resistance Level	$R_{DOH}$	$V_{DD} = 3.5V$ ; $D_{out} = 3.0V$ ;VN=0V	2.5	5.0	10.0	k $\Omega$
$D_{out}$ Low Resistance Level	$R_{DOL}$	$V_{DD} = 1.8V$ ; $D_{out} = 0.5V$ ;VN=1.8V	2.5	5.0	10.0	k $\Omega$
Internal Resistance between VN and $V_{DD}$	$R_{VND}$	$V_{DD} = 1.8V$ ; VN=0V	100	300	900	k $\Omega$
Internal Resistance between VN and GND	$R_{VNG}$	$V_{DD} = 3.5V$ ; VN=3.5V	10	20	40	k $\Omega$



**AAT8660I DETECTION VOLTAGE AND DELAY TIME (25 )**

PARAMETER	SYMBOL	TEST CONDITION	MIN	TYP	MAX	UNIT
Over Charge Threshold Voltage	$V_{C1}$	Detect Rising Edge of Supply Voltage	4.250	4.300	4.350	V
Over Charge Release Voltage	$V_{C2}$	Detect Falling Edge of Supply Voltage	$V_{C1}-0.30$	$V_{C1}-0.20$	$V_{C1}-0.10$	V
Over Discharge Threshold Voltage	$V_{D1}$	Detect Falling Edge of Supply Voltage	2.220	2.300	2.380	V
Over Discharge Release Voltage	$V_{D2}$	Detect Rising Edge of Supply Voltage	$V_{D1}-0.08$	$V_{D1}$	$V_{D1}+0.08$	V
Over Charge Delay Time	$t_{C1}$	$V_{DD} = 3.6V$ to $4.5V$	0.700	1.000	1.300	s
Over Discharge Delay Time	$t_{D1}$	$V_{DD} = 3.6V$ to $2.4V$	87.5	125.0	162.5	ms
Over Current Level 1 Detection Voltage	$V_{OC1}$	Detect Rising Edge of “VN” Pin Voltage ( $D_{out}$ Response with $t_{OC1}$ Delay Time)	110	130	150	mV
Over Current Level 2 Detection Voltage	$V_{OC2}$	Detect Rising Edge of “VN” Pin Voltage ( $D_{out}$ Response with $t_{OC2}$ Delay Time)	400	490	600	mV
Short Circuit Detection Voltage	$V_{short}$	$V_{DD} = 3.0V$ , Detect Rising Edge of “VN” Pin Voltage ( $D_{out}$ Response with $t_{short}$ Delay Time)	$V_{DD}-1.7$	$V_{DD}-1.3$	$V_{DD}-0.9$	V
Over Current Level 1 Detection Delay Time	$t_{OC1}$	$V_{DD} = 3.0V$	5.6	8.0	10.4	ms
Over Current Level 2 Detection Delay Time	$t_{OC2}$	Room Temp. $\Rightarrow$ Low or High Temp. $\Rightarrow$ $V_{DD} = 3.0V$	1.4 1.1	2.0 2.0	2.6 3.4	ms ms
Short Circuit Detection Delay Time	$t_{short}$	$V_{DD} = 3.0V$		10	50	$\mu$ s
Charger Detection Voltage	$V_{CHR}$	Detect Rising Edge of “ $D_{out}$ ” Pin Voltage (when $V_{D1} < V_{DD} < V_{D2}$ )	-2.0	-1.3	-0.6	V
$C_{out}$ High Resistance Level	$R_{COH}$	$V_{DD} = 3.5V$ ; $C_{out} = 3.0V$ ;VN=0V	1	2	10	k $\Omega$
$C_{out}$ Low Resistance Level	$R_{COL}$	$V_{DD} = 4.5V$ ; $C_{out} = 0.5V$ ;VN=0V	150	602	2,380	k $\Omega$
$D_{out}$ High Resistance Level	$R_{DOH}$	$V_{DD} = 3.5V$ ; $D_{out} = 3.0V$ ;VN=0V	2.5	5.0	10.0	k $\Omega$
$D_{out}$ Low Resistance Level	$R_{DOL}$	$V_{DD} = 1.8V$ ; $D_{out} = 0.5V$ ;VN=1.8V	2.5	5.0	10.0	k $\Omega$
Internal Resistance between VN and $V_{DD}$	$R_{VND}$	$V_{DD} = 1.8V$ ; VN=0V	100	300	900	k $\Omega$
Internal Resistance between VN and GND	$R_{VNG}$	$V_{DD} = 3.5V$ ; VN=3.5V	10	20	40	k $\Omega$



**AAT8660J DETECTION VOLTAGE AND DELAY TIME (25 )**

PARAMETER	SYMBOL	TEST CONDITION	MIN	TYP	MAX	UNIT
Over Charge Threshold Voltage	$V_{C1}$	Detect Rising Edge of Supply Voltage	4.230	4.280	4.330	V
Over Charge Release Voltage	$V_{C2}$	Detect Falling Edge of Supply Voltage	$V_{C1}-0.30$	$V_{C1}-0.20$	$V_{C1}-0.10$	V
Over Discharge Threshold Voltage	$V_{D1}$	Detect Falling Edge of Supply Voltage	2.201	2.281	2.361	V
Over Discharge Release Voltage	$V_{D2}$	Detect Rising Edge of Supply Voltage	$V_{D1}-0.08$	$V_{D1}$	$V_{D1}+0.08$	V
Over Charge Delay Time	$t_{C1}$	$V_{DD} = 3.6V$ to $4.5V$	0.700	1.000	1.300	s
Over Discharge Delay Time	$t_{D1}$	$V_{DD} = 3.6V$ to $2.4V$	87.5	125.0	162.5	ms
Over Current Level 1 Detection Voltage	$V_{OC1}$	Detect Rising Edge of "VN" Pin Voltage ( $D_{out}$ Response with $t_{OC1}$ Delay Time)	180	200	220	mV
Over Current Level 2 Detection Voltage	$V_{OC2}$	Detect Rising Edge of "VN" Pin Voltage ( $D_{out}$ Response with $t_{OC2}$ Delay Time)	400	510	600	mV
Short Circuit Detection Voltage	$V_{short}$	$V_{DD} = 3.0V$ , Detect Rising Edge of "VN" Pin Voltage ( $D_{out}$ Response with $t_{short}$ Delay Time)	$V_{DD}-1.7$	$V_{DD}-1.3$	$V_{DD}-0.9$	V
Over Current Level 1 Detection Delay Time	$t_{OC1}$	$V_{DD} = 3.0V$	5.6	8.0	10.4	ms
Over Current Level 2 Detection Delay Time	$t_{OC2}$	Room Temp. $\Rightarrow$ Low or High Temp. $\Rightarrow$ $V_{DD} = 3.0V$	1.4 1.1	2.0 2.0	2.6 3.4	ms ms
Short Circuit Detection Delay Time	$t_{short}$	$V_{DD} = 3.0V$		10	50	$\mu$ s
Charger Detection Voltage	$V_{CHR}$	Detect Rising Edge of " $D_{out}$ " Pin Voltage (when $V_{D1} < V_{DD} < V_{D2}$ )	-2.0	-1.3	-0.6	V
$C_{out}$ High Level Resistance	$R_{COH}$	$V_{DD} = 3.5V$ ; $C_{out} = 3.0V$ ;VN=0V	1	2	10	k $\Omega$
$C_{out}$ Low Level Resistance	$R_{COL}$	$V_{DD} = 4.5V$ ; $C_{out} = 0.5V$ ;VN=0V	150	602	2,380	k $\Omega$
$D_{out}$ High Level Resistance	$R_{DOH}$	$V_{DD} = 3.5V$ ; $D_{out} = 3.0V$ ;VN=0V	2.5	5.0	10.0	k $\Omega$
$D_{out}$ Low Level Resistance	$R_{DOL}$	$V_{DD} = 1.8V$ ; $D_{out} = 0.5V$ ;VN=1.8V	2.5	5.0	10.0	k $\Omega$
Internal Resistance between VN and $V_{DD}$	$R_{VND}$	$V_{DD} = 1.8V$ ; VN=0V	100	300	900	k $\Omega$
Internal Resistance between VN and GND	$R_{VNG}$	$V_{DD} = 3.5V$ ; VN=3.5V	10	20	40	k $\Omega$



**SUMMARY OF AAT8660 DETECTION VOLTAGE AND DELAY TIME (25° C)**

PARAMETER	SYMBOL	DEVICE	MIN	TYP	MAX	UNIT
Over Charge Threshold Voltage	$V_{C1}$	AAT8660A	4.275	4.325	4.375	V
		AAT8660B	4.300	4.350	4.400	V
		AAT8660C	4.250	4.300	4.350	V
		AAT8660D	4.230	4.280	4.330	V
		AAT8660E	4.230	4.280	4.330	V
		AAT8660F	4.275	4.325	4.375	V
		AAT8660G	4.300	4.350	4.400	V
		AAT8660H	4.250	4.300	4.350	V
		AAT8660I	4.250	4.300	4.350	V
		AAT8660J	4.230	4.280	4.330	V
		Over Charge Release Voltage	$V_{C2}$	AAT8660A	$V_{C1}-0.35$	$V_{C1}-0.25$
AAT8660B	$V_{C1}-0.30$			$V_{C1}-0.20$	$V_{C1}-0.10$	V
AAT8660C	$V_{C1}-0.30$			$V_{C1}-0.20$	$V_{C1}-0.10$	V
AAT8660D	$V_{C1}-0.30$			$V_{C1}-0.20$	$V_{C1}-0.10$	V
AAT8660E	$V_{C1}-0.30$			$V_{C1}-0.20$	$V_{C1}-0.10$	V
AAT8660F	$V_{C1}-0.35$			$V_{C1}-0.25$	$V_{C1}-0.15$	V
AAT8660G	$V_{C1}-0.30$			$V_{C1}-0.20$	$V_{C1}-0.10$	V
AAT8660H	$V_{C1}-0.30$			$V_{C1}-0.20$	$V_{C1}-0.10$	V
AAT8660I	$V_{C1}-0.30$			$V_{C1}-0.20$	$V_{C1}-0.10$	V
AAT8660J	$V_{C1}-0.30$			$V_{C1}-0.20$	$V_{C1}-0.10$	V
Over Discharge Threshold Voltage	$V_{D1}$			AAT8660A	2.420	2.500
		AAT8660B	2.220	2.300	2.380	V
		AAT8660C	2.220	2.300	2.380	V
		AAT8660D	2.201	2.281	2.361	V
		AAT8660E	2.201	2.281	2.361	V
		AAT8660F	2.420	2.500	2.580	V
		AAT8660G	2.220	2.300	2.380	V
		AAT8660H	2.220	2.300	2.380	V
		AAT8660I	2.220	2.300	2.380	V
		AAT8660J	2.201	2.281	2.361	V



AAT8660 Series

**SUMMARY OF AAT8660 DETECTION VOLTAGE AND DELAY TIME (25 )**

PARAMETER	SYMBOL	DEVICE	MIN	TYP	MAX	UNIT
Over Discharge Release Voltage	$V_{D2}$	AAT8660A	$V_{D1}+0.3$	$V_{D1}+0.4$	$V_{D1}+0.5$	V
		AAT8660B	$V_{D1}+0.6$	$V_{D1}+0.7$	$V_{D1}+0.8$	V
		AAT8660C	$V_{D1}-0.08$	$V_{D1}$	$V_{D1}+0.08$	V
		AAT8660D	$V_{D1}-0.08$	$V_{D1}$	$V_{D1}+0.08$	V
		AAT8660E	$V_{D1}+0.5$	$V_{D1}+0.6$	$V_{D1}+0.7$	V
		AAT8660F	$V_{D1}+0.3$	$V_{D1}+0.4$	$V_{D1}+0.5$	V
		AAT8660G	$V_{D1}+0.6$	$V_{D1}+0.7$	$V_{D1}+0.8$	V
		AAT8660H	$V_{D1}-0.08$	$V_{D1}$	$V_{D1}+0.08$	V
		AAT8660I	$V_{D1}-0.08$	$V_{D1}$	$V_{D1}+0.08$	V
		AAT8660J	$V_{D1}-0.08$	$V_{D1}$	$V_{D1}+0.08$	V
Over Charge Delay Time	$t_{C1}$	AAT8660A	0.700	1.000	1.300	s
		AAT8660B	0.088	0.125	0.163	s
		AAT8660C	0.700	1.000	1.300	s
		AAT8660D	0.700	1.000	1.300	s
		AAT8660E	0.700	1.000	1.300	s
		AAT8660F	0.700	1.000	1.300	s
		AAT8660G	0.088	0.125	0.163	s
		AAT8660H	0.700	1.000	1.300	s
		AAT8660I	0.700	1.000	1.300	s
		AAT8660J	0.700	1.000	1.300	s
Over Discharge Delay Time	$t_{D1}$	AAT8660A	87.5	125.0	162.5	ms
		AAT8660B	22.4	32.0	41.6	ms
		AAT8660C	87.5	125.0	162.5	ms
		AAT8660D	87.5	125.0	162.5	ms
		AAT8660E	87.5	125.0	162.5	ms
		AAT8660F	87.5	125.0	162.5	ms
		AAT8660G	22.4	32.0	41.6	ms
		AAT8660H	87.5	125.0	162.5	ms
		AAT8660I	87.5	125.0	162.5	ms
		AAT8660J	87.5	125.0	162.5	ms

**SUMMARY OF AAT8660 DETECTION VOLTAGE AND DELAY TIME (25 )**

PARAMETER	SYMBOL	DEVICE	MIN	TYP	MAX	UNIT
Over Current Level 1 Detection Voltage	$V_{OC1}$	AAT8660A	130	150	170	mV
		AAT8660B	130	150	170	mV
		AAT8660C	80	100	120	mV
		AAT8660D	110	130	150	mV
		AAT8660E	80	100	120	mV
		AAT8660F	80	100	120	mV
		AAT8660G	180	200	220	mV
		AAT8660H	130	150	170	mV
		AAT8660I	110	130	150	mV
		AAT8660J	180	200	220	mV
Over Current Level 2 Detection Voltage	$V_{OC2}$	AAT8660A	400	500	600	mV
		AAT8660B	400	500	600	mV
		AAT8660C	400	480	600	mV
		AAT8660D	400	490	600	mV
		AAT8660E	400	480	600	mV
		AAT8660F	400	480	600	mV
		AAT8660G	400	510	600	mV
		AAT8660H	400	500	600	mV
		AAT8660I	400	490	600	mV
		AAT8660J	400	510	600	mV
Over Current Level 1 Detection Delay Time	$t_{OC1}$	AAT8660A	5.6	8.0	10.4	ms
		AAT8660B	2.8	4.0	5.2	ms
		AAT8660C	5.6	8.0	10.4	ms
		AAT8660D	5.6	8.0	10.4	ms
		AAT8660E	5.6	8.0	10.4	ms
		AAT8660F	5.6	8.0	10.4	ms
		AAT8660G	2.8	4.0	5.2	ms
		AAT8660H	5.6	8.0	10.4	ms
		AAT8660I	5.6	8.0	10.4	ms
		AAT8660J	5.6	8.0	10.4	ms





**TIMING CHART**  
**AAT8660 (CHARGE AND DISCHARGE)**

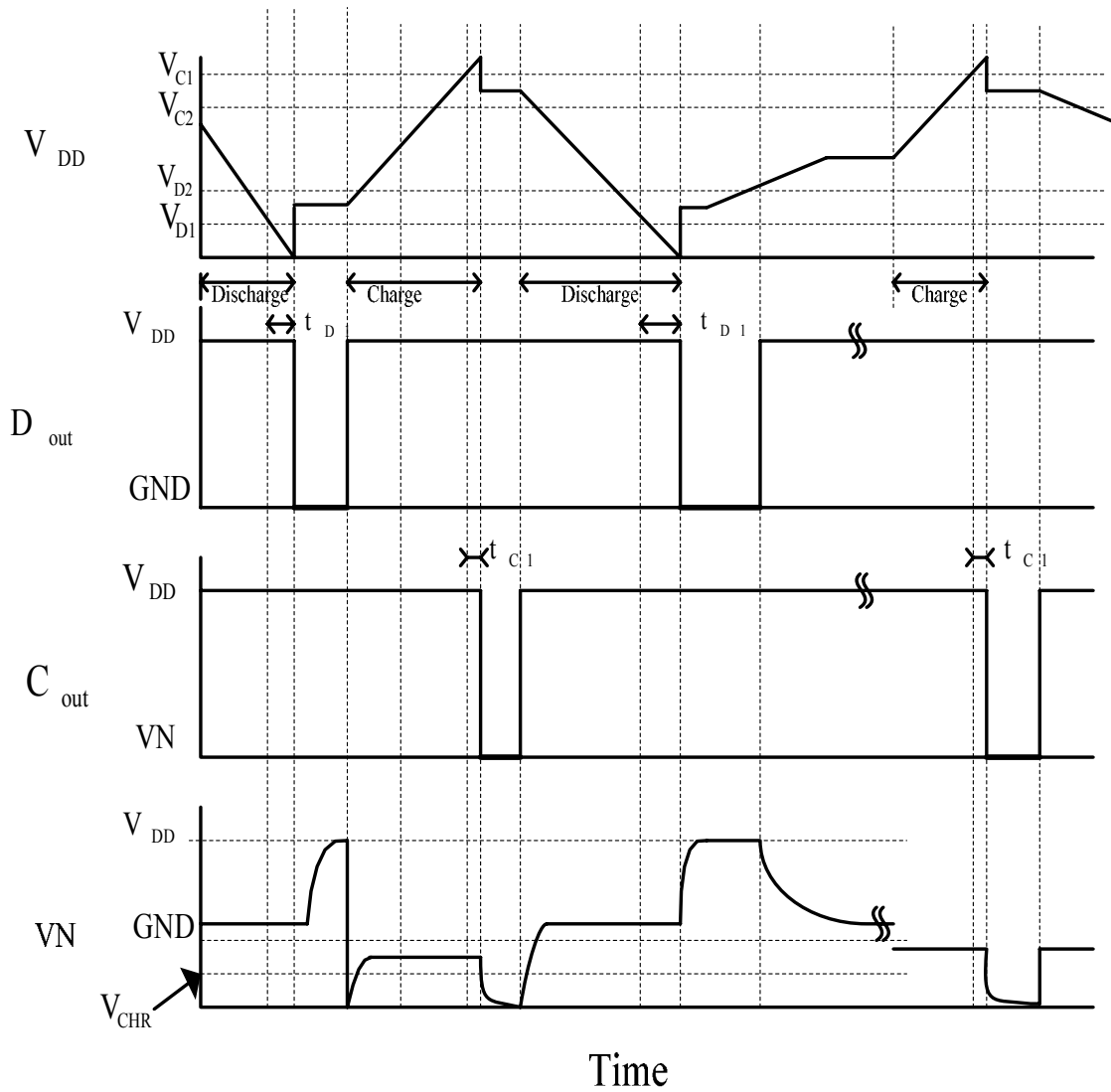



**TIMING CHART**

**AAT8660 (UNUSUAL CHARGE CURRENT, OVER CURRENT, SHORT CIRCUIT)**

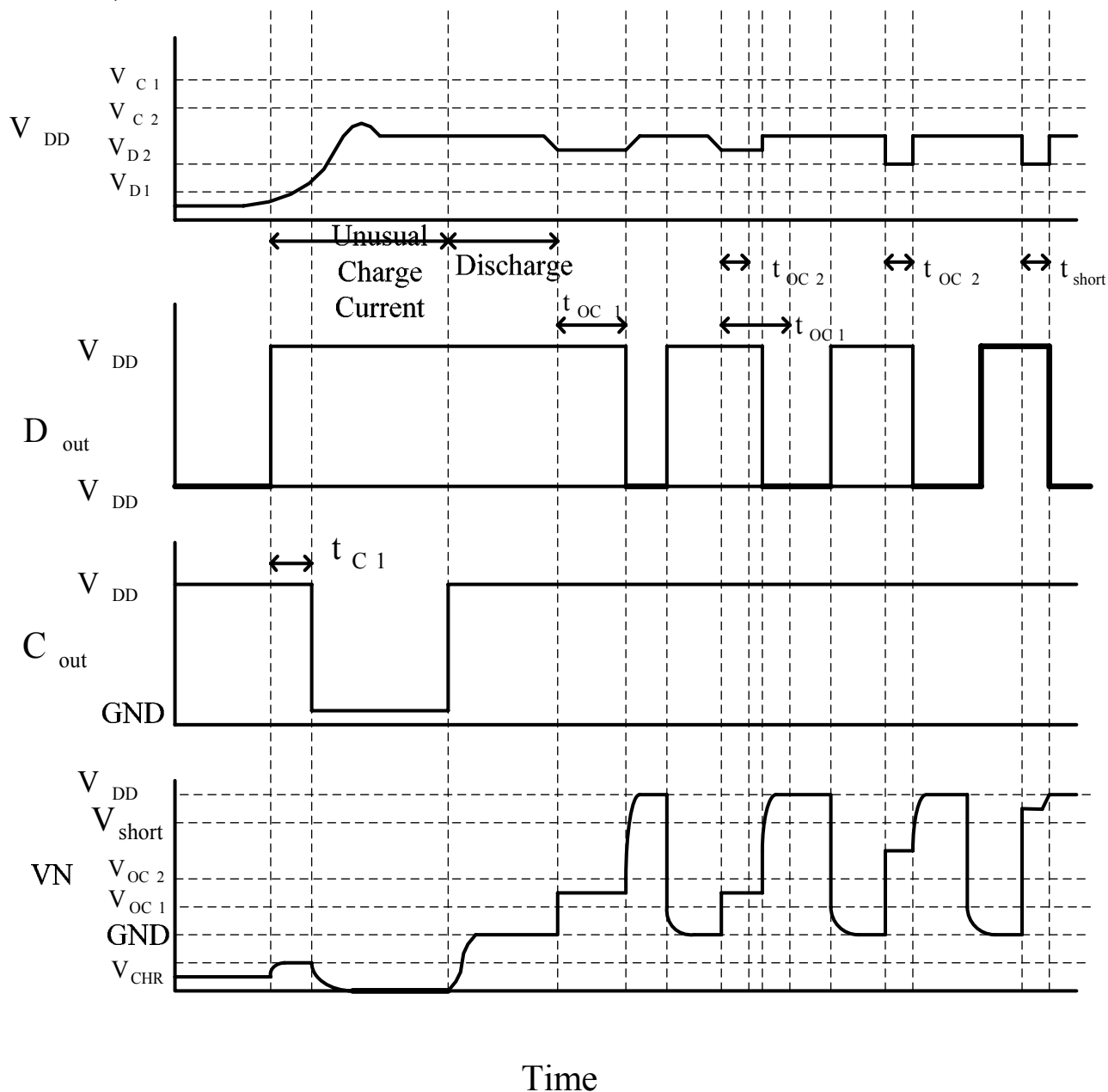



TYPICAL APPLICATION

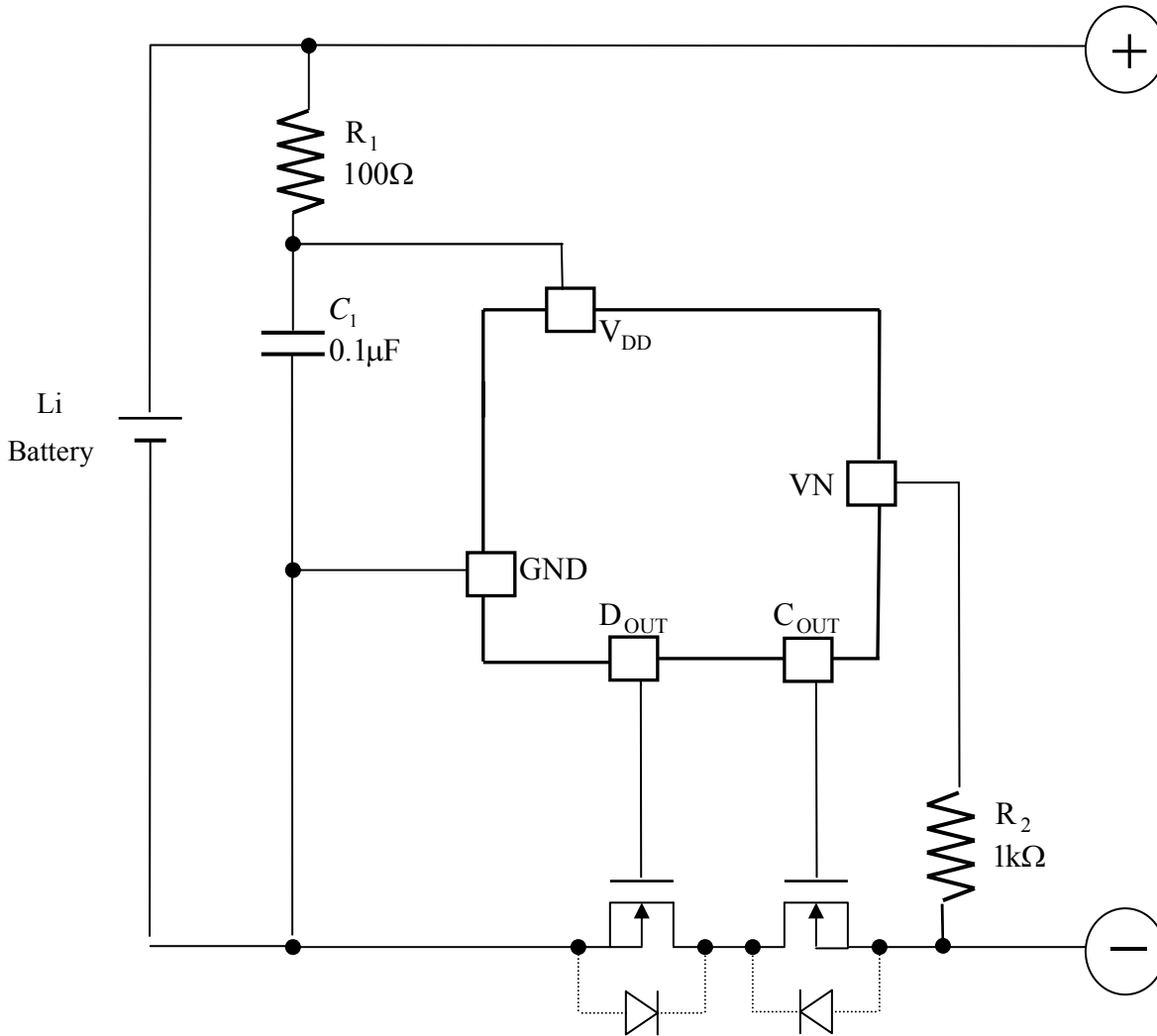



PACKAGE DIMENSION

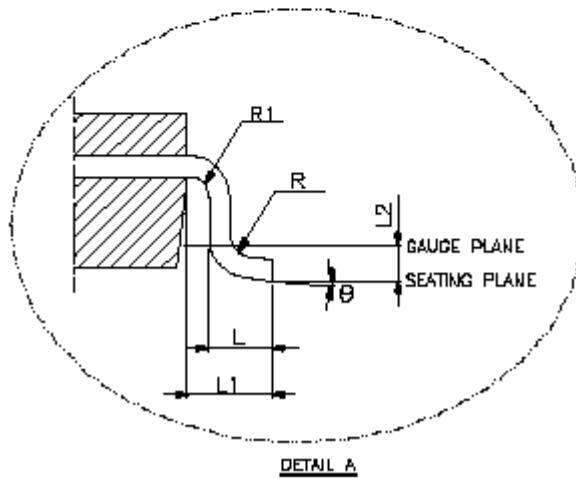
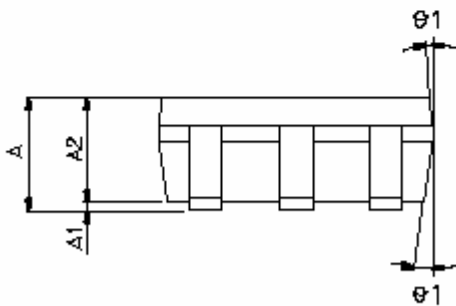
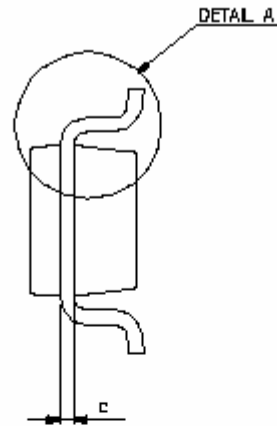
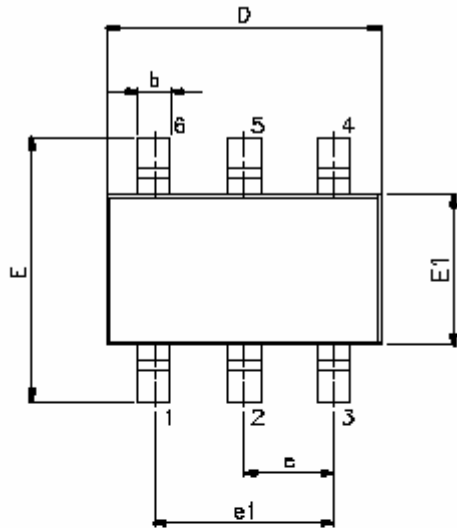



**PACKAGE DIMENSIONS (CONT.)**

**VARIATION (ALL DIMENSIONS SHOWN IN MILLIMETERS)**

SYMBOL	MIN	TYP	MAX
A	-----	-----	1.45
A1	-----	-----	0.15
A2	0.90	1.15	1.30
b	0.30	-----	0.50
c	0.08	-----	0.22
D	2.90 BSC		
E	2.80 BSC		
E1	1.60 BSC		
e	0.95 BSC		
e1	1.90 BSC		
L	0.30	0.45	0.60
L1	0.60 REF		
L2	0.25 BSC		
R	0.10	-----	-----
R1	0.10	-----	0.25
θ	0°	4°	8°
θ1	5°	10°	15°

NOTE:

1 JEDEC OUTLINE: MO-178 AB



**TAPE AND REEL**

**PACKING METHOD: 3,000PCS/REEL, 5 REELS/BOX**

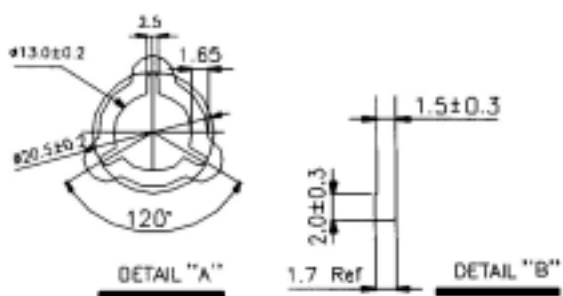
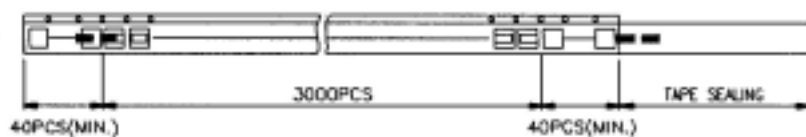
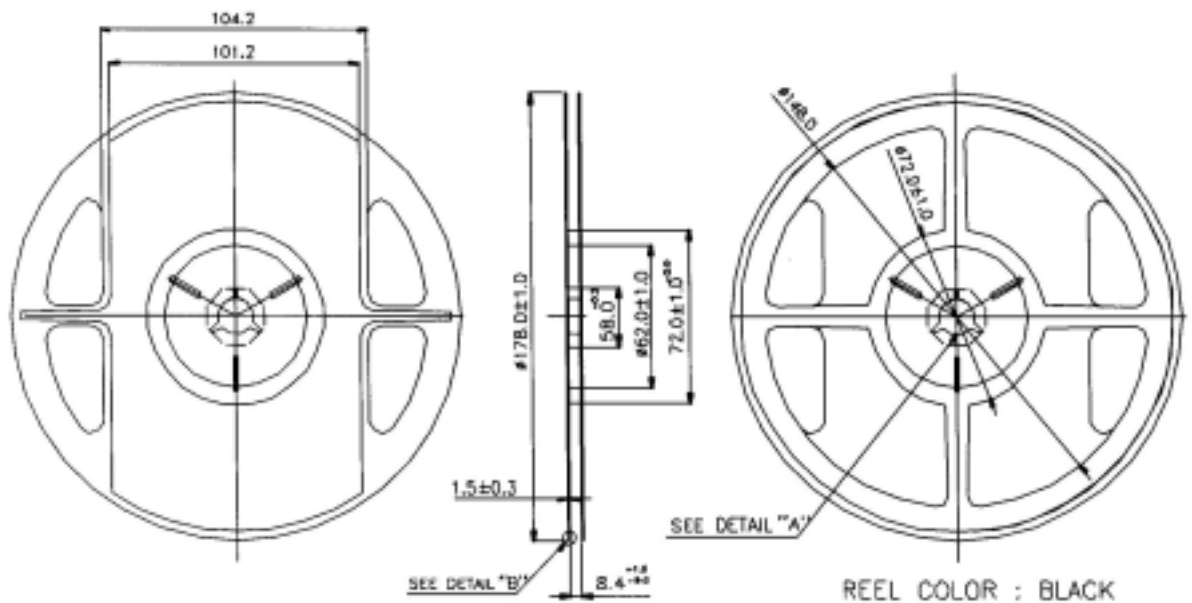



TAPE AND REEL (CONT.)

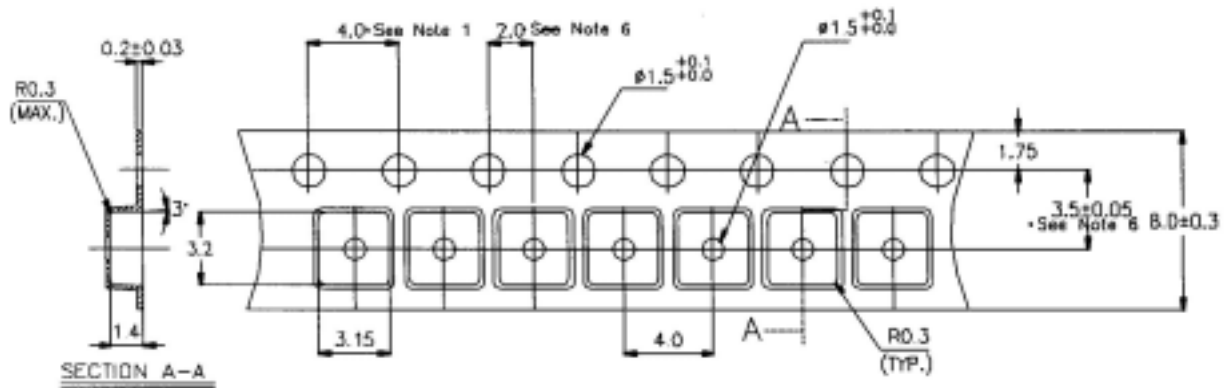
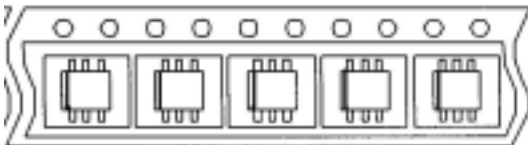

X.XXX X	± 0.0025
X.XXX	± 0.006
X.XX	± 0.025
X.X	± 0.10
X	± 0.25

UNIT: MILLIMETERS



## PART MARKING

### PREVIOUS SOT26 TOP MARKING

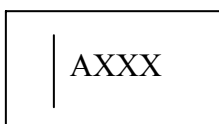

NOTE: SOT26 HAS NO BACK MARKING.

### CURRENT SOT26 TOP MARKING

