

THIS DOCUMENT AND THE DATA DISCLOSED HEREIN OR HEREWITH IS NOT TO BE REPRODUCED, USED, OR DISCLOSED IN WHOLE OR IN PART TO ANYONE WITHOUT PERMISSION OF VICOR CORP.

REV.	DESCRIPTION	DATE	APPROVED
#5	FORMAT WAS B SIZE: REVISED NO OF FINS AND NOTES, .140 THD DEPTH WAS .120	DPK 11/14/97	SWN
#6	REVISED PROFILE	DPK 11/17/97	SWN
#7	ADDED +.010 TOL TO DIM	DPK 12/8/97	SWN
#8	.49 WAS .490: REMOVED P/N STAMPING	DPK 8/24/98	SWN
#9	ADDED .40 DIM: ADDED "O" TO .190, .100	DPK 9/10/98	SWN
#A	ADDED NOTE 4, CRITICAL CHA. "O"	AK 10/7/99	SWN

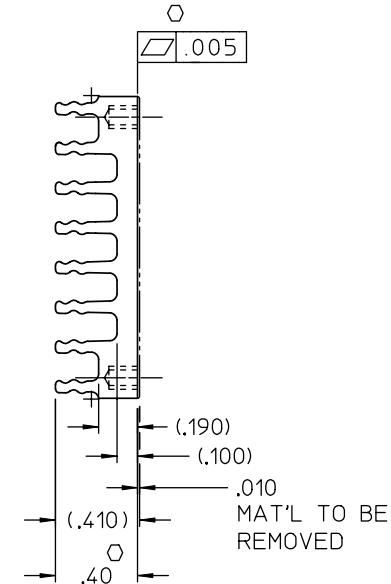
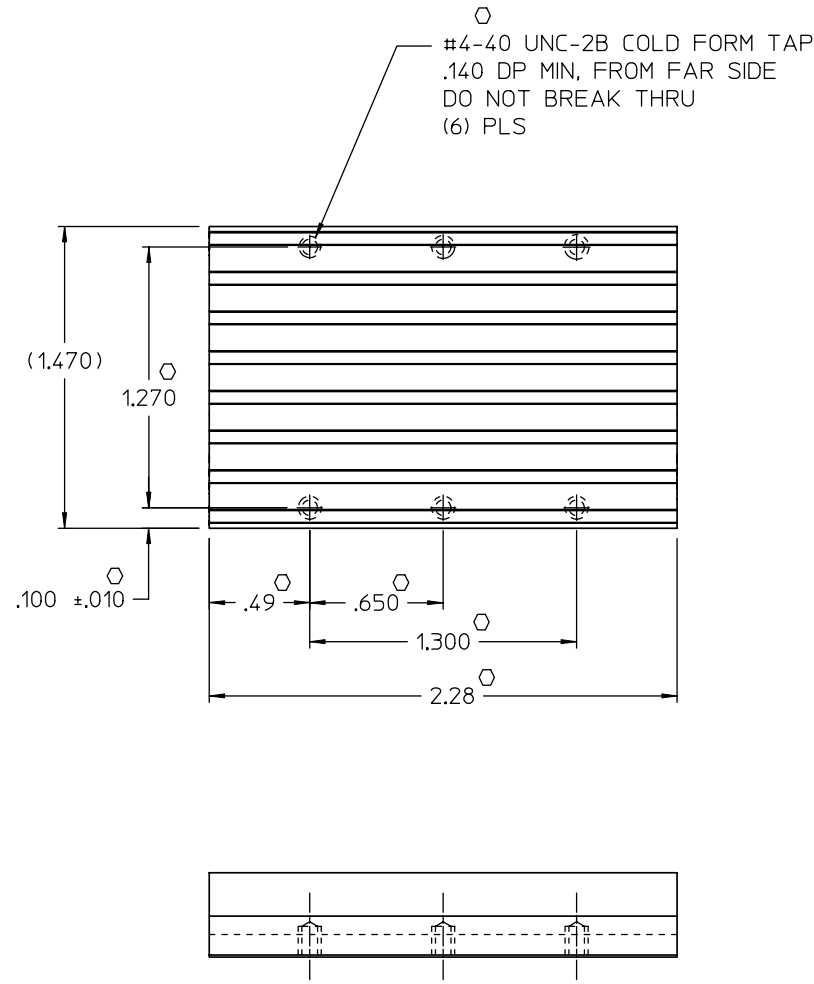

NOTES

1. MAKE FROM VICOR EXTRUSION 16287.
2. REMOVE ALL BURRS AND SHARP EDGES.
3. FINISH: CLEAR CHROMATE.
4. "O" DENOTES CRITICAL CHARACTERISTICS FOR LOT INSPECTION.

DRAWN BY D.P. KELLY		DATE 2/97	
UNLESS OTHERWISE SPECIFIED DIMENSIONS ARE IN INCHES- TOLERANCES ARE: FRACTIONS DECIMALS ANGLES 1/64 .XX- .01 °1° .XXX-.005			
THIRD ANGLE PROJECTION 		SIZE C	FSCM NO. 67131
DO NOT SCALE DRAWING		DWG NO. 16285	REV #A
SCALE 2=1		SHEET 1 OF 1	

VICOR

**HTSNK, "C" LONG. .4H
 LOW FLOW, THREADED**