

3.3V 16-Bit Bidirectional Transceiver with 3-State Outputs

Product Features

- PI74ALVCH16245 is designed for low voltage operation
- $V_{CC} = 2.3V$ to $3.6V$
- Hysteresis on all inputs
- Typical V_{OLP} (Output Ground Bounce)
< $0.8V$ at $V_{CC} = 3.3V, T_A = 25^\circ C$
- Typical V_{OHV} (Output V_{OH} Undershoot)
< $2.0V$ at $V_{CC} = 3.3V, T_A = 25^\circ C$
- Bus Hold retains last active bus state during 3-STATE, eliminating the need for external pullup resistors
- Industrial operation at $-40^\circ C$ to $+85^\circ C$
- Packages available:
 - 48-pin 240 mil wide plastic TSSOP (A)
 - 48-pin 300 mil wide plastic SSOP (V)

Product Description

Pericom Semiconductor's PI74ALVCH series of logic circuits are produced using the Company's advanced 0.5 micron CMOS technology, achieving industry leading speed grades.

The PI74ALVCH16245 is a 16-bit bidirectional transceiver designed for asynchronous two-way communication between data buses. The direction control input pin (xDIR) determines the direction of data flow through the bidirectional transceiver. The Direction and Output Enable controls are designed to operate this device as either two independent 8-bit transceivers or one 16-bit transceiver. The output enable (\overline{OE}) input, when HIGH, disables both A and B ports by placing them in HIGH Z condition.

To ensure the high-impedance state during power up or power down, \overline{OE} should be tied to V_{CC} through a pull-up resistor; the minimum value of the resistor is determined by the current sinking ability of the driver.

Active bus-hold circuitry is provided to hold unused or floating data inputs at a valid logic level.

Logic Block Diagram

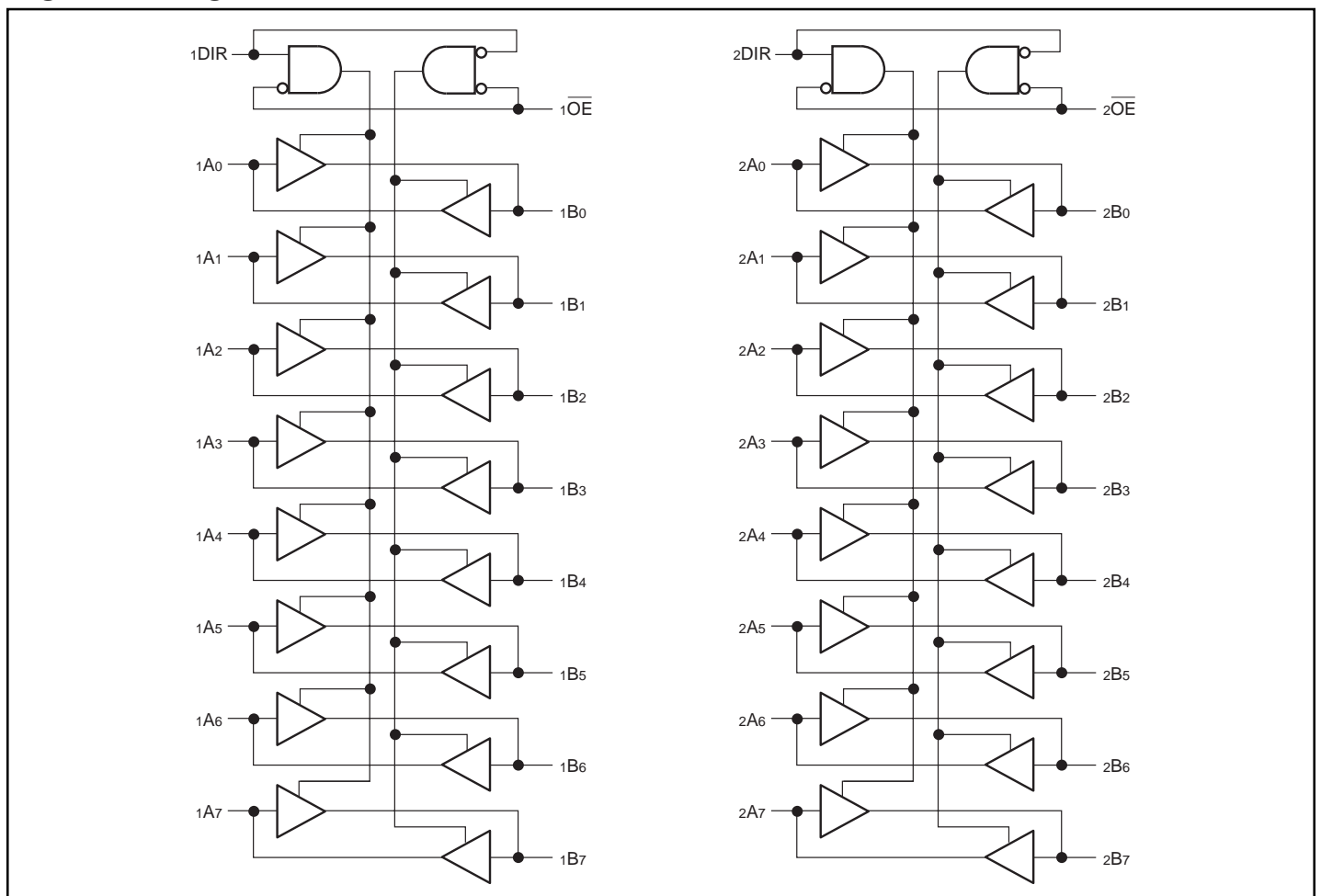

Product Pin Description

Pin Name	Description
\overline{xOE}	3-State Output Enable Inputs (Active LOW)
xDIR	Direction Control Input
xAx	Side A Inputs or 3-STATE Inputs
xBx	Side B Outputs or 3-STATE Outputs
GND	Ground
VCC	Power

Truth Table⁽¹⁾

Inputs ⁽¹⁾		Outputs ⁽¹⁾
\overline{xOE}	xDIR	
L	L	Bus B Data to Bus A
L	H	Bus A Data to Bus B
H	X	Z

Notes:

- 1. H = High Voltage Level
- L = Low Voltage Level
- X = Don't Care
- Z = High Impedance

Product Pin Configuration

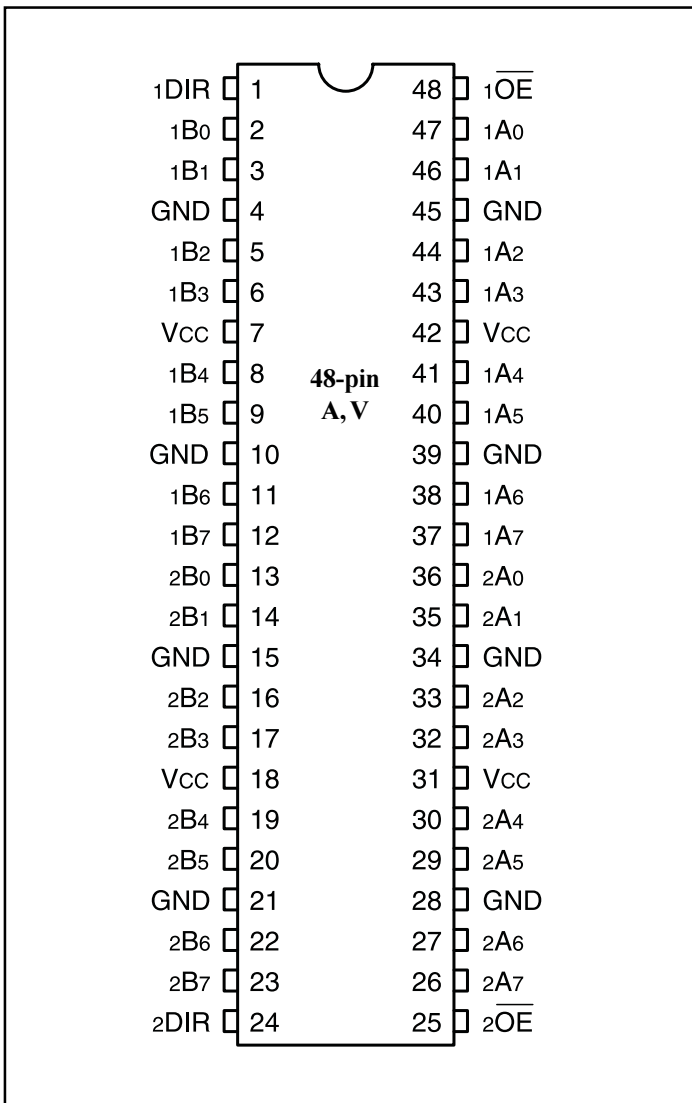

Maximum Ratings

(Above which the useful life may be impaired. For user guidelines, not tested.)

Storage Temperature	-65°C to +150°C
Ambient Temperature with Power Applied	-40°C to +85°C
Input Voltage Range, V_{IN}	-0.5V to $V_{CC}+4.6V$
Output Voltage Range, V_{OUT}	-0.5V to $V_{CC}+0.5V$
DC Input Voltage	-0.5V to +5.0V
DC Output Current	50 mA
Power Dissipation	1.0W

Note:

Stresses greater than those listed under MAXIMUM RATINGS may cause permanent damage to the device. This is a stress rating only and functional operation of the device at these or any other conditions above those indicated in the operational sections of this specification is not implied. Exposure to absolute maximum rating conditions for extended periods may affect reliability.

DC Electrical Characteristics (Over the Operating Range, $T_A = -40^\circ\text{C}$ to $+85^\circ\text{C}$, $V_{CC} = 3.3V \pm 10\%$)

Parameters	Description	Test Conditions ⁽¹⁾	Min.	Typ. ⁽²⁾	Max.	Units
V_{CC}	Supply Voltage		2.3		3.6	
$V_{IH}^{(3)}$	Input HIGH Voltage	$V_{CC} = 2.3V$ to $2.7V$	1.7			
		$V_{CC} = 2.7V$ to $3.6V$	2.0			
$V_{IL}^{(3)}$	Input LOW Voltage	$V_{CC} = 2.3V$ to $2.7V$			0.7	
		$V_{CC} = 2.7V$ to $3.6V$			0.8	
$V_{IN}^{(3)}$	Input Voltage		0		V_{CC}	
$V_{OUT}^{(3)}$	Output Voltage		0		V_{CC}	
V_{OH}	Output HIGH Voltage	$I_{OH} = -100\mu A$, $V_{CC} = \text{Min. to Max.}$	$V_{CC} - 0.2$			
		$V_{IH} = 1.7V$, $I_{OH} = -6mA$, $V_{CC} = 2.3V$	2.0			
		$V_{IH} = 1.7V$, $I_{OH} = -12mA$, $V_{CC} = 2.3V$	1.7			
		$V_{IH} = 2.0V$, $I_{OH} = -12mA$, $V_{CC} = 2.7V$	2.2			
		$V_{IH} = 2.0V$, $I_{OH} = -12mA$, $V_{CC} = 3.0V$	2.4			
		$V_{IH} = 2.0V$, $I_{OH} = -24mA$, $V_{CC} = 3.0V$	2.0			
V_{OL}	Output LOW Voltage	$I_{OL} = 100\mu A$, $V_{IL} = \text{Min. to Max.}$			0.2	
		$V_{IL} = 0.7V$, $I_{OL} = 6mA$, $V_{CC} = 2.3V$			0.4	
		$V_{IL} = 0.7V$, $I_{OL} = 12mA$, $V_{CC} = 2.3V$			0.7	
		$V_{IL} = 0.8V$, $I_{OL} = 12mA$, $V_{CC} = 2.7V$			0.4	
		$V_{IL} = 0.8V$, $I_{OL} = 24mA$, $V_{CC} = 3.0V$			0.55	
$I_{OH}^{(3)}$	Output HIGH Current	$V_{CC} = 2.3V$			-12	
		$V_{CC} = 2.7V$			-12	
		$V_{CC} = 3.0V$			-24	
$I_{OL}^{(3)}$	Output LOW Current	$V_{CC} = 2.3V$			12	
		$V_{CC} = 2.7V$			12	
		$V_{CC} = 3.0V$			24	

DC Electrical Characteristics-Continued (Over the Operating Range, $T_A = -40^\circ\text{C}$ to $+85^\circ\text{C}$, $V_{CC} = 3.3\text{V} \pm 10\%$)

Parameters	Description	Test Conditions ⁽¹⁾	Min.	Typ. ⁽²⁾	Max.	Units
I_{IN}	Input Current	$V_{IN} = V_{CC}$ or GND, $V_{CC} = 3.6\text{V}$			± 5	μA
$I_{IN}(\text{HOLD})$	Input Hold Current	$V_{IN} = 0.7\text{V}$, $V_{CC} = 2.3\text{V}$	45			
		$V_{IN} = 1.7\text{V}$, $V_{CC} = 2.3\text{V}$	-45			
		$V_{IN} = 0.8\text{V}$, $V_{CC} = 3.0\text{V}$	75			
		$V_{IN} = 2.0\text{V}$, $V_{CC} = 3.0\text{V}$	-75			
		$V_{IN} = 0$ to 3.6V , $V_{CC} = 3.6\text{V}$			± 500	
I_{OZ}	Output Current (3-STATE Outputs)	$V_{OUT} = V_{CC}$ or GND, $V_{CC} = 3.6\text{V}$			± 10	
I_{CC}	Supply Current	$V_{CC} = 3.6\text{V}$, $I_{OUT} = 0\mu\text{A}$, $V_{IN} = \text{GND}$ or V_{CC}			40	
ΔI_{CC}	Supply Current per Input @ TTL HIGH	$V_{CC} = 3.0\text{V}$ to 3.6V One Input at $V_{CC} - 0.6\text{V}$ Other Inputs at V_{CC} or GND			750	
C_I	Control Inputs	$V_{IN} = V_{CC}$ or GND, $V_{CC} = 3.3\text{V}$		4		pF
C_{IO}	A or B Ports	$V_O = V_{CC}$ or GND, $V_{CC} = 3.3\text{V}$		7		

Notes:

- For Max. or Min. conditions, use appropriate value specified under Electrical Characteristics for the applicable device type.
- Typical values are at $V_{CC} = 3.3\text{V}$, $+25^\circ\text{C}$ ambient and maximum loading.
- Unused Control Inputs must be held HIGH or LOW to prevent them from floating.

Switching Characteristics over Operating Range⁽¹⁾

Parameters	From (Input)	To (Output)	$V_{CC} = 2.5\text{V} \pm 0.2\text{V}$		$V_{CC} = 2.7\text{V}$		$V_{CC} = 3.3\text{V} \pm 0.3\text{V}$		Units
			Min. ⁽²⁾	Max.	Min. ⁽²⁾	Max.	Min. ⁽²⁾	Max.	
t_{PD}	A or B	B or A	1.0	3.7		3.6	1.0	3	ns
t_{EN}	$\overline{\text{OE}}$	B or A	1.0	5.7		5.4	1.0	4.4	
t_{DIS}	$\overline{\text{OE}}$	B or A	1.5	5.2		4.6	1.0	4.1	
Description									
$\Delta t/\Delta v^{(3)}$	Input Transition Rise or Fall		0	10	0	10	0	10	ns/V

Notes:

- See test circuit and waveforms.
- Minimum limits are guaranteed but not tested on Propagation Delays.
- Recommended operating condition.

Operating Characteristics, $T_A = 25^\circ\text{C}$

Parameter		Test Conditions	$V_{CC} = 2.5\text{V} \pm 0.2\text{V}$	$V_{CC} = 3.3\text{V} \pm 0.3\text{V}$	Units
			Typical		
C_{PD} Power Dissipation Capacitance	Outputs Enabled	$C_L = 50\text{pF}$ $f = 10\text{MHz}$	22	29	pF
	Outputs Disabled		4	5	