

### Features

- Differential Linearity Error .....  $\pm 0.5$  LSB
- Integral Linearity Error .....  $\pm 0.5$  LSB
- Integral Linearity Compensation Circuit
- Low Input Capacitance ..... 21pF
- Wide Analog Input Bandwidth ..... 150MHz
- Low Power Consumption ..... 760mW
- Internal  $1/2$  Frequency Divider Circuit (w/Reset Function)
- CLK/2 Clock Output
- Compatible with ECL, PECL and TTL Digital Input Levels
- 1:2 Demultiplexed Output Pin
- Surface Mounting Package
- Direct Replacement for Sony CXA3026Q

### Applications

- RGB Graphics Processing (LCD, PDP)
- Digital Oscilloscopes
- Digital Communications (QPSK, QAM)
- Magnetic Recording (PRML)

### Description

The HI3026 is an 8-bit, high-speed, flash analog-to-digital converter optimized for high speed, low power, and ease of use. With a 120 MSPS encode rate capability and full-power analog bandwidth of 150MHz, this component is ideal for applications requiring the highest possible dynamic performance.

To minimize system cost and power dissipation, only a +5V power supply is required. The HI3026's clock input interfaces directly to TTL, ECL, or PECL logic and will operate with single-ended inputs. The user may select 16-bit demultiplexed output or 8-bit single channel digital outputs. The demultiplexed mode interleaves the data through two 8-bit channels at  $1/2$  the clock rate. Operation in demultiplexed mode reduces the speed and cost of external digital interfaces, while allowing the A/D converter to be clocked to the full 120 MSPS conversion rate.

Fabricated with an advanced Bipolar process, the HI3026 is provided in a space-saving 48-lead MQFP surface mount plastic package and is specified over the  $-20^{\circ}\text{C}$  to  $75^{\circ}\text{C}$  temperature range. For a faster clock rate, please refer to the HI3026A (140 MSPS), AnswerFAX Document number 4246.

### Ordering Information

PART NUMBER	TEMP. RANGE (°C)	PACKAGE	PKG. NO.
HI3026JCQ	-20 to 75	48 Ld MQFP	Q48.12x12-S
HI3026EVAL	25	Evaluation Board	

### Pinout

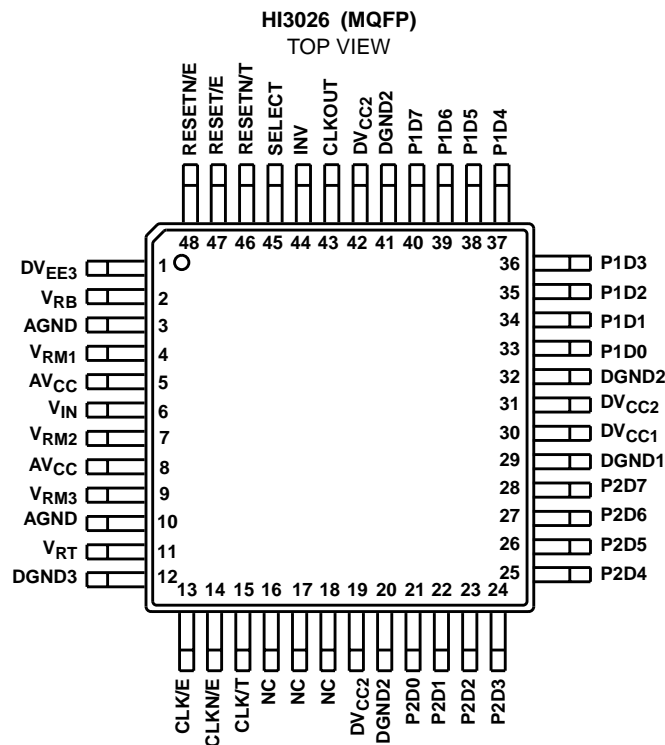

Block Diagram

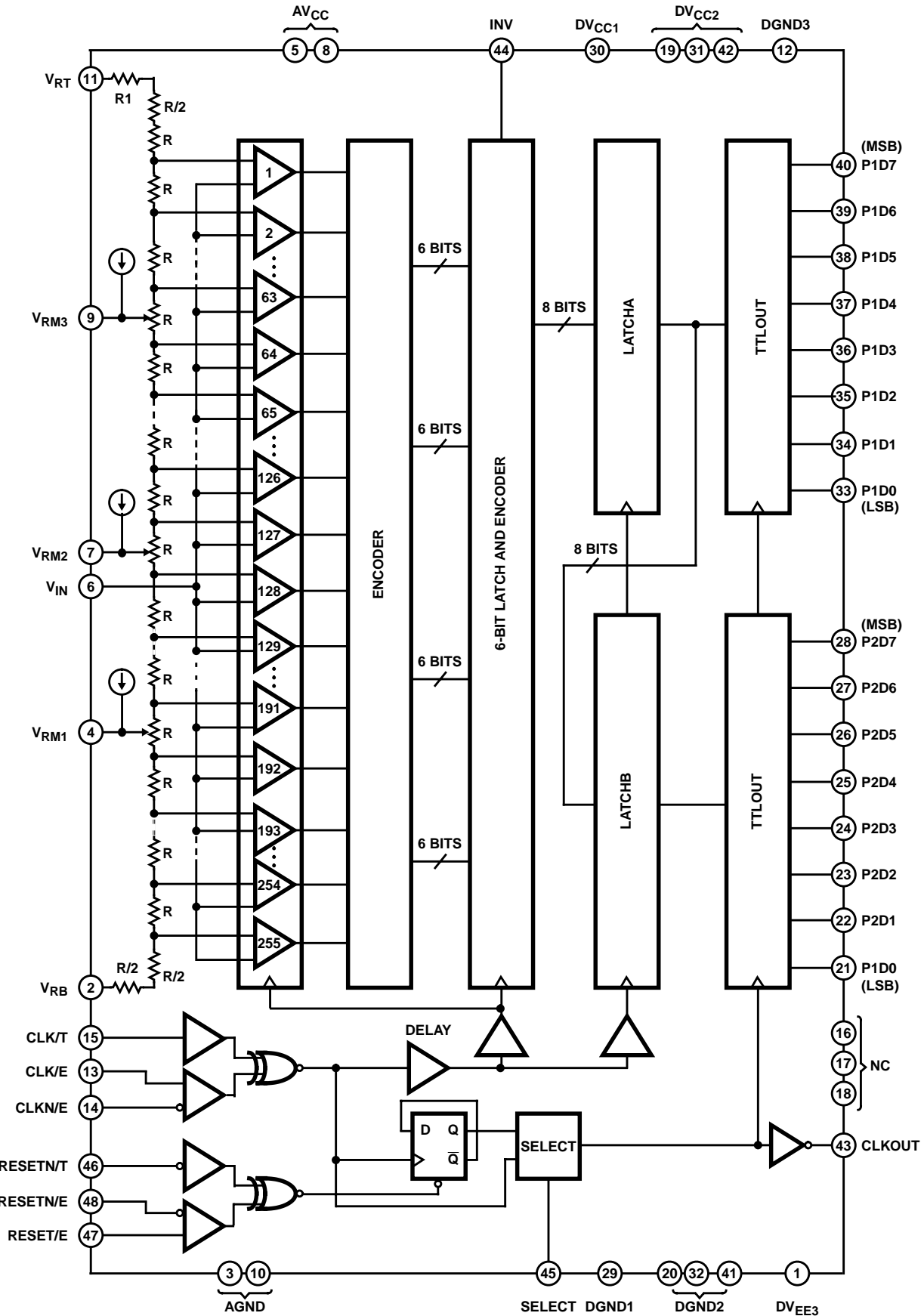

**Absolute Maximum Ratings**  $T_A = 25^\circ\text{C}$

Supply Voltage ( $V_{CC}$ , $DV_{CC1}$ , $DV_{CC2}$ )	-0.5V to 7.0V
(DGND3)	-0.5V to 7.0V
( $DV_{EE3}$ )	-7.0V to 0.5V
(DGND3 - $DV_{EE3}$ )	-0.5V to 7.0V
Analog Input Voltage ( $V_{IN}$ )	$V_{RT} - 2.7V$ to $AV_{CC}$
Reference Input Voltage ( $V_{RT}$ )	2.7V to $AV_{CC}$
( $V_{RB}$ )	$V_{IN} - 2.7V$ to $AV_{CC}$
( $ V_{RT} - V_{RB} $ )	2.5V
Digital Input Voltage	
ECL (***/E (Note 2))	$DV_{EE3}$ to 0.5V
PECL (***/E)	-0.5V to DGND3
TTL (***/T, INV)	-0.5V to $DV_{CC1}$
Other (SELECT)	-0.5V to $DV_{CC1}$
$V_{ID}$ ( ***/E - ***/N/E  (Note 3))	2.7V

**Thermal Information**

Thermal Resistance (Typical, Note 1)	$\theta_{JA}$ ( $^\circ\text{C}/\text{W}$ )
MQFP Package	63
Maximum Junction Temperature	150 $^\circ\text{C}$
Maximum Storage Temperature Range	-65 $^\circ\text{C}$ to 150 $^\circ\text{C}$
Maximum Lead Temperature (Soldering 10s)	300 $^\circ\text{C}$
(Lead Tips Only)	

**Recommended Operating Conditions**

**WITH A SINGLE POWER SUPPLY**

	MIN	TYP	MAX
Supply Voltage			
$DV_{CC1}$ , $DV_{CC2}$ , $AV_{CC}$	+4.75	+5.0	+5.25V
DGND1, DGND2, AGND	-0.05	0	+0.05V
DGND3	+4.75	+5.0	+5.25V
$DV_{EE3}$	-0.05	0	+0.05V
Analog Input Voltage ( $V_{IN}$ )	$V_{RB}$	-	$V_{RT}$
Reference Input Voltage			
$V_{RT}$	+2.9	-	+4.1V
$V_{RB}$	1.4	-	+2.6V
$ V_{RT} - V_{RB} $	1.5	-	2.1V
Digital Input Voltage			
PECL (***/E) $V_{IH}$	DGND3 - 1.05	DGND3 - 1.4V	
PECL (***/E) $V_{IL}$	DGND3 - 3.2	DGND3 - 1.4V	
TTL (***/T, INV) $V_{IH}$	2.0V	-	-
TTL (***/T, INV) $V_{IL}$	-	-	0.8V
Other (SELECT) $V_{IH}$	-	$DV_{CC1}$	-
Other (SELECT) $V_{IL}$	-	DGND1	-
VID (Note 3) ( ***/E - ***/N/E )	0.4	0.8	-
Max Conversion Rate ( $f_C$ , Straight Mode)	100	-	-
	MSPS		
Max Conversion Rate ( $f_C$ , DMUX Mode)	120	-	-
	MSPS		
Ambient Temperature ( $T_A$ )	-20 $^\circ\text{C}$ to 75 $^\circ\text{C}$		

**WITH DUAL POWER SUPPLIES**

	MIN	TYP	MAX
Supply Voltage			
$DV_{CC1}$ , $DV_{CC2}$ , $AV_{CC}$	+4.75	+5.0	+5.25V
DGND1, DGND2, AGND	-0.05	0	+0.05V
DGND3	-0.05	0	+0.05V
$DV_{EE3}$	-5.5	-5.0	-4.75V
Analog Input Voltage ( $V_{IN}$ )	$V_{RB}$	-	$V_{RT}$
Reference Input Voltage			
$V_{RT}$	+2.9	-	+4.1V
$V_{RB}$	1.4	-	+2.6V
$ V_{RT} - V_{RB} $	1.5	-	2.1V
Digital Input Voltage			
ECL (***/E) $V_{IH}$	DGND3 - 1.05	DGND3 - 0.5V	
ECL (***/E) $V_{IL}$	DGND3 - 3.2	DGND3 - 1.4V	
TTL (***/T, INV) $V_{IH}$	2.0V	-	-
TTL (***/T, INV) $V_{IL}$	-	-	0.8V
Other (SELECT) $V_{IH}$	-	$DV_{CC1}$	-
Other (SELECT) $V_{IL}$	-	DGND1	-
$V_{ID}$ (Note 3) ( ***/E - ***/N/E )	0.4	0.8	-
Max Conversion Rate ( $f_C$ , Straight Mode)	100	-	-
	MSPS		
Max Conversion Rate ( $f_C$ , DMUX Mode)	120	-	-
	MSPS		
Ambient Temperature ( $T_A$ )	-20 $^\circ\text{C}$ to 75 $^\circ\text{C}$		

CAUTION: Stresses above those listed in "Absolute Maximum Ratings" may cause permanent damage to the device. This is a stress only rating and operation of the device at these or any other conditions above those indicated in the operational sections of this specification is not implied.

NOTES:

- $\theta_{JA}$  is measured with the component mounted on an evaluation PC board in free air.
- \*\*\*/E and \*\*\*/T indicate CLK/E and CLK/T, etc., for the pin name.
- $V_{ID}$ : Input Voltage Differential.

**Electrical Specifications**  $DV_{CC1, 2}$ ,  $AV_{CC}$ , DGND3 = +5V, DGND1, 2, AGND,  $DV_{EE3} = 0V$ ,  $V_{RT} = 4V$ ,  $V_{RB} = 2V$ ,  $T_A = 25^\circ\text{C}$

PARAMETER	TEST CONDITIONS	MIN	TYP	MAX	UNITS
Resolution		-	8	-	Bits
<b>DC CHARACTERISTICS</b>					
Integral Linearity Error, $E_{IL}$	$V_{IN} = 2V_{P-P}$ , $f_C = 5$ MSPS	-	-	$\pm 0.5$	LSB
Differential Linearity Error, $E_{DL}$		-	-	$\pm 0.5$	LSB
<b>ANALOG INPUT</b>					
Analog Input Capacitance, $C_{IN}$	$V_{IN} = +3.0V + 0.07V_{RMS}$	-	21	-	pF
Analog Input Resistance, $R_{IN}$		4	-	50	k $\Omega$
Analog Input Current, $I_{IN}$		0	-	500	$\mu\text{A}$

# HI3026

**Electrical Specifications**  $DV_{CC1,2}, AV_{CC}, DGND3 = +5V, DGND1, 2, AGND, DV_{EE3} = 0V, V_{RT} = 4V, V_{RB} = 2V,$   
 $T_A = 25^\circ C$  (Continued)

PARAMETER	TEST CONDITIONS	MIN	TYP	MAX	UNITS
<b>REFERENCE INPUT</b>					
Reference Resistance (Note 4), $R_{REF}$		75	115	155	$\Omega$
Reference Current (Note 5), $I_{REF}$		9.7	17.4	28	mA
Offset Voltage $V_{RT}$ Side, EOT		2	-	15	mV
Offset Voltage $V_{RB}$ Side, EOB		2	-	10	mV
<b>DIGITAL INPUT (ECL, PECL)</b>					
Digital Input Voltage: High, $V_{IH}$		DGND3 - 1.05	-	DGND3 - 0.5	V
Digital Input Voltage: Low, $V_{IL}$		DGND3 - 3.2	-	DGND3 - 1.4	V
Threshold Voltage, $V_{TH}$		-	DGND3 - 1.2	-	V
Digital Input Current: High, $I_{IH}$	$V_{IH} = DGND3 - 0.8V$	-50	-	+50	$\mu A$
Digital Input Current: Low, $I_{IL}$	$V_{IL} = DGND3 - 1.6V$	-75	-	0	$\mu A$
Digital Input Capacitance		-	-	5	pF
<b>DIGITAL INPUT (TTL)</b>					
Digital Input Voltage: High, $V_{IH}$		2.0	-	-	V
Digital Input Voltage: Low, $V_{IL}$		-	-	0.8	V
Threshold Voltage, $V_{TH}$		-	1.5	-	V
Digital Input Current: High, $I_{IH}$	$V_{IH} = 3.5V$	-50	-	0	$\mu A$
Digital Input Current: Low, $I_{IL}$	$V_{IL} = 0.2V$	-500	-	0	$\mu A$
Digital Input Capacitance		-	-	5	pF
<b>DIGITAL OUTPUT (TTL)</b>					
Digital Output Voltage: High, $V_{OH}$	$I_{OH} = -2mA$	2.4	-	-	V
Digital Output Voltage: Low, $V_{OL}$	$I_{OL} = 1mA$	-	-	0.5	V
<b>SWITCHING CHARACTERISTICS</b>					
Maximum Conversion Rate, $f_C$	DMUX Mode	120	-	-	MSPS
Aperture Jitter, $t_{AJ}$		-	10	-	ps
Sampling Delay, $t_{DS}$		3	4.5	6	ns
Clock High Pulse Width, $t_{PW1}$	CLK	3.2	-	-	ns
Clock Low Pulse Width, $t_{PW0}$	CLK	3.2	-	-	ns
Reset Pulse Width, $t_{PWR}$ (Note 6)	RESETN	$t \times 2$	-	-	ns
RESET Signal Setup Time, $t_{RS}$	RESETN-CLK	3.5	-	-	ns
RESET Signal Hold Time, $t_{RH}$	RESETN-CLK	0	-	-	ns
CLKOUT Output Delay, $t_{DCLK}$	( $C_L = 5pF$ )	3.5	7	9	ns
Data Output Delay (Note 6), $t_{DO1}$ $t_{DO2}$	DEMUX Mode ( $C_L = 5pF$ )	t	t + 1	t + 2	ns
	( $C_L = 5pF$ )	4.5	8	10	ns
Output Rise Time, $t_r$	0.8 to 2.0V ( $C_L = 5pF$ )	-	2	-	ns
Output Fall Time, $t_f$	0.8 to 2.0V ( $C_L = 5pF$ )	-	2	-	ns
<b>DYNAMIC CHARACTERISTICS</b>					
Input Bandwidth	$V_{IN} = 2V_{P-P}, -3dB$	150	-	-	MHz
S/N Ratio	$f_C = 120$ MSPS, $f_{IN} = 1kHz$ Full Scale, DMUX Mode	-	46	-	dB
	$f_C = 120$ MSPS, $f_{IN} = 29.999MHz$ Full Scale, DMUX Mode	-	40	-	dB

# HI3026

**Electrical Specifications**  $DV_{CC1,2}, AV_{CC}, DGND3 = +5V, DGND1,2, AGND, DV_{EE3} = 0V, V_{RT} = 4V, V_{RB} = 2V,$   
 $T_A = 25^{\circ}C$  (Continued)

PARAMETER	TEST CONDITIONS	MIN	TYP	MAX	UNITS
Error Rate (Note 7)	$f_C = 120$ MSPS, $f_{IN} = 1$ kHz Full Scale, DMUX Mode, Error > 16 LSB	-	-	$10^{-12}$	TPS
	$f_C = 120$ MSPS, $f_{IN} = 29.999$ MHz Full Scale, DMUX Mode, Error > 16 LSB	-	-	$10^{-9}$	TPS
	$f_C = 100$ MSPS, $f_{IN} = 24.999$ MHz Full Scale, Straight Mode, Error > 16 LSB	-	-	$10^{-9}$	TPS
<b>POWER SUPPLY</b>					
Supply Current, $I_{CC}$		125	145	185	mA
Supply Current, $I_{EE}$		0.4	0.6	0.8	mA
Power Consumption (Note 8), $P_D$		660	760	960	mW

**NOTES:**

4.  $R_{REF}$ : Resistance value between  $V_{RT}$  and  $V_{RB}$ .

$$5. I_{REF} = \frac{V_{RT} - V_{RB}}{R_{REF}}$$

$$6. T = \frac{1}{f_C}$$

7. The unit of measure TPS: Times Per Sample.

$$8. P_D = (I_{CC} + I_{EE}) \cdot V_{CC} + \frac{(V_{RT} - V_{RB})^2}{V_{REF}}$$

## Timing Diagrams

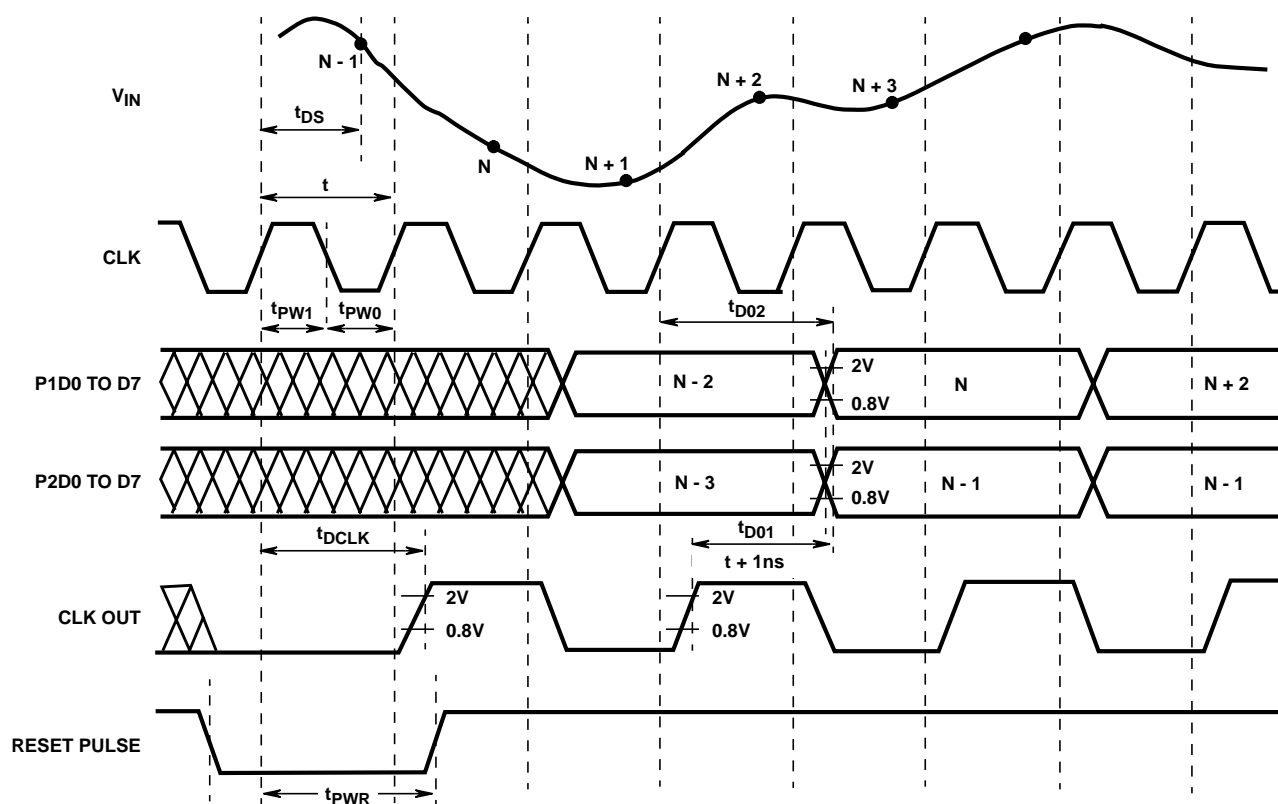

FIGURE 1. DEMUX MODE TIMING CHART (SELECT =  $V_{CC}$ )

Timing Diagrams

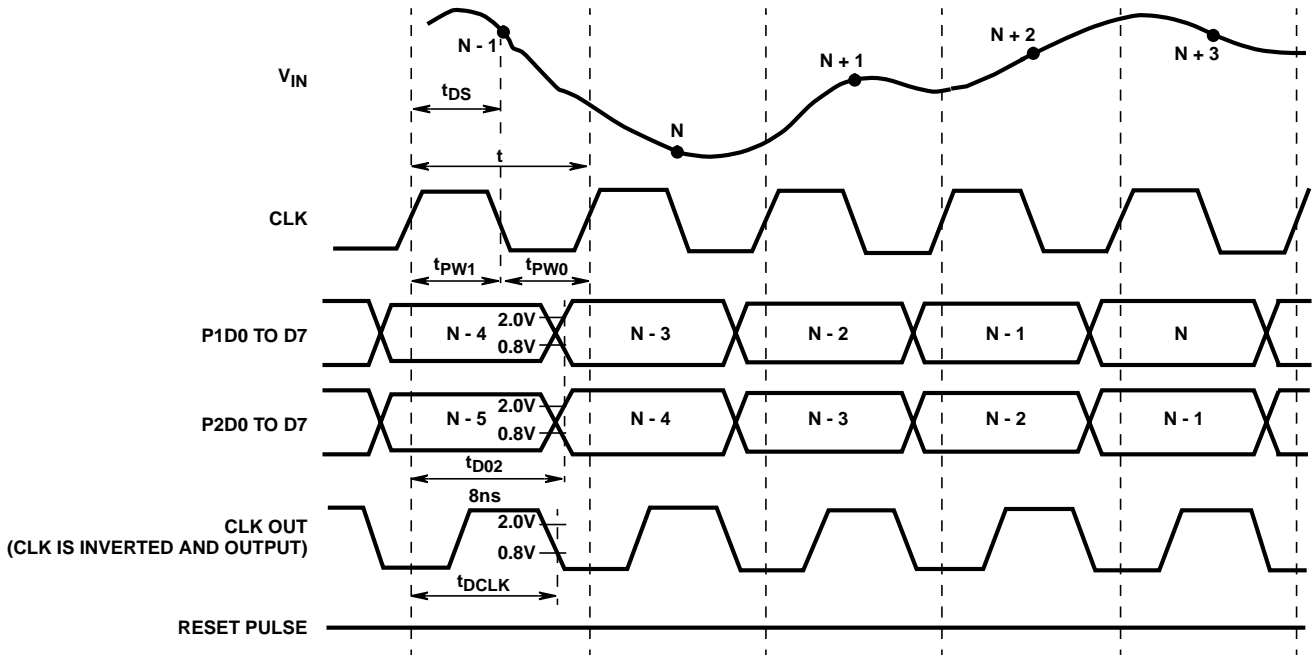

FIGURE 2. STRAIGHT MODE TIMING CHART (SELECT = GND)

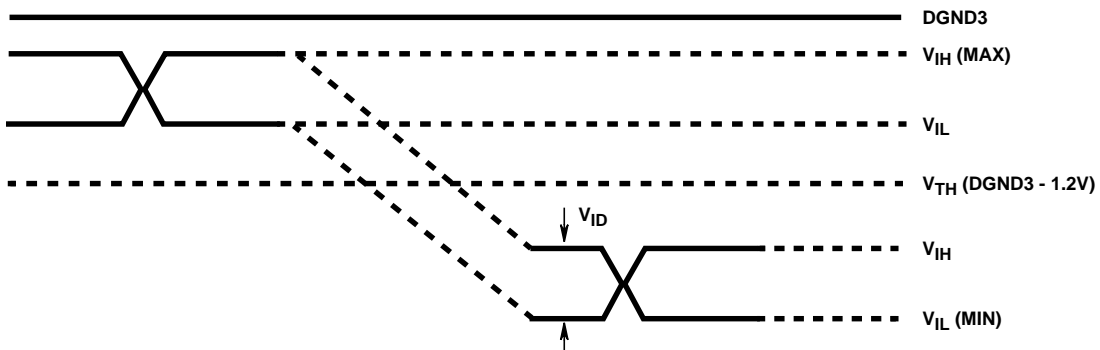

FIGURE 3. ECL AND PECL SWITCHING LEVEL

Pin Descriptions

PIN NO	SYMBOL	I/O	TYPICAL VOLTAGE LEVEL	EQUIVALENT CIRCUIT	DESCRIPTION
3, 10	AGND		GND		Analog Ground. Separated from the digital ground.
5, 8	AV <sub>CC</sub>		+5V (Typ)		Analog Power Supply. Separated from the digital power supply.
20, 29 32, 41	DGND1 DGND2		GND		Digital Ground.
19, 30 31, 42	DV <sub>CC</sub> 1 DV <sub>CC</sub> 2		+5V (Typ)		Digital Power Supply.
12	DGND3		+5V (Typ) (With a Single Power Supply) GND (With Dual Power Supplies)		Digital Power Supply. Ground for ECL input. -5V for PECL and TTL input.

**Pin Descriptions** (Continued)

PIN NO	SYMBOL	I/O	TYPICAL VOLTAGE LEVEL	EQUIVALENT CIRCUIT	DESCRIPTION
1	DVEE3		GND (With a Single Power Supply) +5V (Typ) (With Dual Power Supplies)		Digital Power Supply. Ground for ECL input. -5V for PECL and TTL input.
16, 17, 18	NC				No Connect pin. Not connected with the internal circuits.
13	CLK/E	I	ECL/PECL		<p>13</p> <p>48</p> <p>14</p> <p>47</p> <p>1.2V</p> <p>DGND3</p> <p>DVEE3</p>
14	CLK/NE	I			<p>CLK/E Complementary Input. When left open, this pin goes to the threshold potential. Only CLK/E can be used for operation, but complementary input is recommended to attain fast and stable operation.</p>
48	RE-SETN/E	I			<p>Reset Input. When the input is set to low level, the built-in CLK frequency divider circuit can be reset.</p>
47	RESET/E	I			<p>RESETN/E Complementary Input. When left open, this pin goes to the threshold voltage. Only RESETN/E can be used for operation.</p>
15	CLK/T	I	TTL		<p>15</p> <p>46</p> <p>DVCC1</p> <p>DGND1</p> <p>DVEE3</p> <p>1.5V</p> <p>R/2</p> <p>R</p>
46	RESETN/T	I			<p>Reset Input. When left open, this input goes to high level. When the input is set to low level, the built-in CLK frequency divider circuit can be reset.</p>
44	INV	I	TTL		<p>44</p> <p>DVCC1</p> <p>DGND1</p> <p>DVEE3</p>
45	SELECT		V <sub>CC</sub> or Ground		<p>45</p> <p>DVCC1</p> <p>DGND1</p> <p>DVEE3</p>

**Pin Descriptions** (Continued)

PIN NO	SYMBOL	I/O	TYPICAL VOLTAGE LEVEL	EQUIVALENT CIRCUIT	DESCRIPTION
11	$V_{RT}$	I	4.0V (Typ)		Top Reference Voltage. Bypass to AGND with a 1 $\mu$ F tantal capacitor and a 0.1 $\mu$ F chip capacitor.
9	$V_{RM3}$		$V_{RB} + \frac{3}{4}(V_{RT} - V_{RB})$		Reference Voltage Mid Point. Bypass to AGND with a 0.1 $\mu$ F chip capacitor.
7	$V_{RM2}$		$V_{RB} + \frac{2}{4}(V_{RT} - V_{RB})$		Reference Voltage Mid Point. Bypass to AGND with a 0.1 $\mu$ F chip capacitor.
4	$V_{RM1}$		$V_{RB} + \frac{1}{4}(V_{RT} - V_{RB})$		Reference Voltage Mid Point. Bypass to AGND with a 0.1 $\mu$ F chip capacitor.
2	$V_{RB}$	I	2.0V (Typ)		Bottom Reference Voltage. Bypass to AGND with a 1 $\mu$ F tantal capacitor and a 0.1 $\mu$ F chip capacitor.
6	$V_{IN}$	I	$V_{RT}$ to $V_{RB}$		Analog Input.
33 to 40	P1D0 to P1D7	O	TTL		Port 1 Side Data Output.
21 to 28	P2D0 to P2D7	O			Port 2 Side Data Output.
43	CLKOUT	O			Clock Output. (See Table 2; Operating Mode Table).



TABLE 1. A/D CODE TABLE

V <sub>IN</sub>	STEP	INV															
		1				0											
		D7	D6	D5	D0	D7	D6	D5	D0								
V <sub>RT</sub>	255	1	1	1	1	1	1	1	1	0	0	0	0	0	0	0	0
	254	1	1	1	1	1	1	1	0	0	0	0	0	0	0	0	1
V <sub>RM2</sub>	128	1	0	0	0	0	0	0	0	0	1	1	1	1	1	1	1
	127	0	1	1	1	1	1	1	1	1	0	0	0	0	0	0	0
V <sub>RB</sub>	1	0	0	0	0	0	0	0	1	1	1	1	1	1	1	1	0
	0	0	0	0	0	0	0	0	0	1	1	1	1	1	1	1	1

**Notes on Operation**

- The HI3026 is a high-speed A/D converter which is capable of TTL, ECL and PECL level clock input. Characteristic impedance should be properly matched to ensure optimum performance during high-speed operation.
- The power supply and grounding have a profound influence on converter performance. The power supply and grounding method are particularly important during high-speed operation. General points for caution are as follows:
  - The ground pattern should be as large as possible. It is recommended to make the power supply and ground patterns wider at an inner layer using a multi-layer board.

- To prevent interference between AGND and DGND and between AV<sub>CC</sub> and DV<sub>CC</sub>, make sure the respective patterns are separated. To prevent a DC offset in the power supply pattern, connect the AV<sub>CC</sub> and DV<sub>CC</sub> lines at one point each, via a ferrite-bead filter. Shorting the AGND and DGND patterns in one place immediately under the A/D converter improves A/D converter performance.
- Ground the power supply pins (AV<sub>CC</sub>, DV<sub>CC1</sub>, DV<sub>CC2</sub>, DV<sub>EE3</sub>) as close to each pin as possible with a 0.1μF or larger ceramic chip capacitor. (Connect the AV<sub>CC</sub> pin to the AGND pattern and the DV<sub>CC1</sub>, DV<sub>CC2</sub>, DV<sub>EE3</sub> pins to the DGND pattern).
- The digital output wiring should be as short as possible. If the digital output wiring is long, the wiring capacitance will increase, deteriorating the output slew rate and resulting in reflection to the output waveform since the original output slew rate is quite fast.
- The analog input pin V<sub>IN</sub> has an input capacitance of approximately 21pF. To drive the A/D converter with proper frequency response, it is necessary to prevent performance deterioration due to parasitic capacitance or parasitic inductance by using a large capacity drive circuit; keeping wiring as short as possible, and using chip parts for resistors and capacitors, etc.
- The V<sub>RT</sub> and V<sub>RB</sub> pins must have adequate bypass to protect them from high-frequency noise. Bypass them to AGND with approximately 1μF tantal capacitor and, 0.1μF capacitor. At this time, approximately DGND3 - 1.2V voltage is generated. However, this is not recommended for use as threshold voltage V<sub>BB</sub> as it is too weak.

When the digital input level is ECL or PECL level, \*\*\*/E pins should be used and \*\*\*/T pins left open. When the digital input level is TTL, \*\*\*/T pins should be used and III/E pins left open.

**Test Circuits**

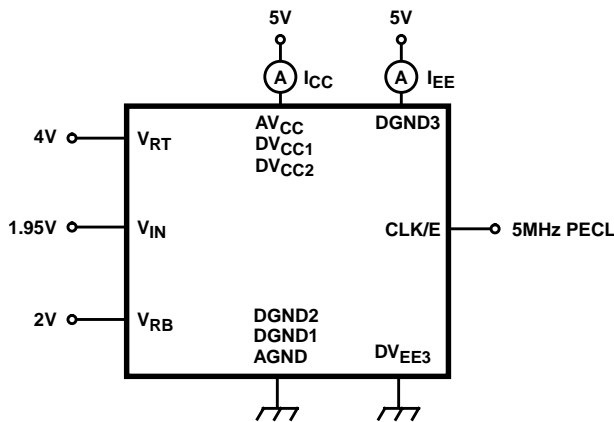

FIGURE 4. CURRENT CONSUMPTION MEASUREMENT CIRCUIT

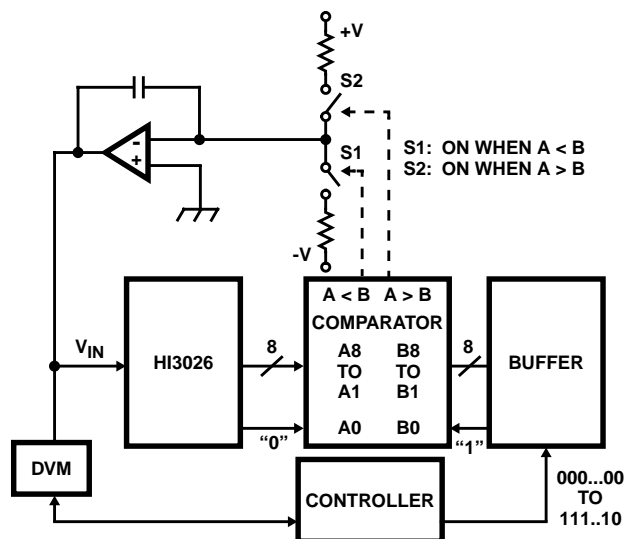

FIGURE 5. INTEGRAL LINEARITY ERROR/DIFFERENTIAL LINEARITY ERROR MEASUREMENT CIRCUIT

**Test Circuits** (Continued)

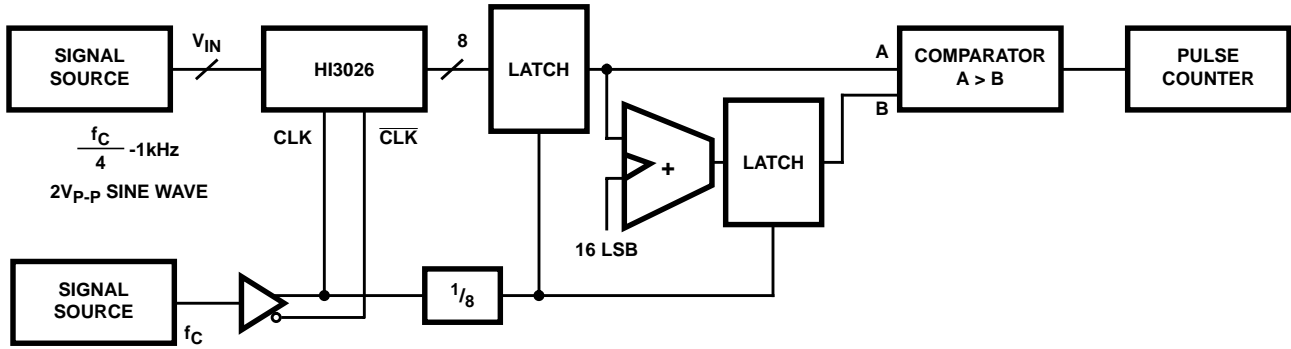

FIGURE 6. ERROR RATE MEASUREMENT CIRCUIT

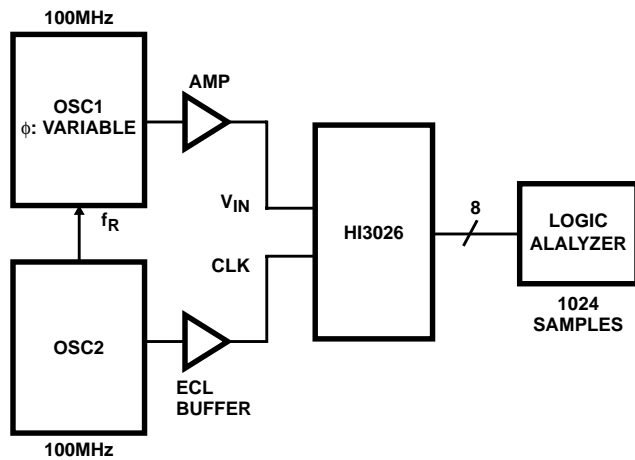
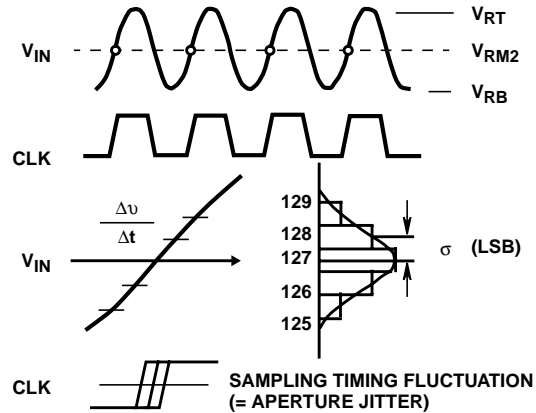

FIGURE 7. SAMPLING DELAY/APERTURE JITTER MEASUREMENT CIRCUIT



NOTE: Where  $\sigma$  (LSB) is the deviation of the output codes when the largest slew rate point is sampled at the clock which has exactly the same frequency as the analog input signal, the aperture jitter  $t_{AJ}$  is:

$$t_{AJ} = \left( \sigma \frac{\Delta v}{\Delta t} \right) = \sigma \left( \frac{256}{2} \times 2\pi f \right).$$

FIGURE 8. APERTURE JITTER MEASUREMENT METHOD

**Operating Modes**

The HI3026 has two types of operating modes which are selected with Pin 45 (SELECT).

TABLE 2. OPERATING MODE TABLE

OPERATING MODE	SELECT	MAXIMUM CONVERSION RATE	DATA OUTPUT	CLOCK OUTPUT
DMUX Mode	V <sub>CC</sub>	120 MSPS	Demultiplexed Output 60 MBPS	The input clock is 1/2 frequency divided and output at 60MHz.
Straight Mode	GND	100 MSPS	Straight Output 100 MBPS	The input clock is inverted and output at 100MHz.

DMUX Mode (See Application Circuits, Figures 18, 19, 20)

Set the SELECT pin to V<sub>CC</sub> for this mode. In this mode, the clock frequency is divided by 2 in the IC, and the data is output after being demultiplexed by this 1/2 frequency divided clock. The 1/2 frequency divided clock, which has adequate setup time and hold time for the output data, is output from the CLKOUT pin.

When using multiple HI3026 units in parallel in this mode, differences in the start timing of the 1/2 frequency divided clock may cause operation as shown in the figure below. As a coun-

termeasure, the HI3026 is equipped with a function which resets the 1/2 frequency divided clock. When resetting this clock, the RESET pulse must be input to the RESET pin. See the Timing Charts for the RESET pulse input timing. The A/D converter can operate at f<sub>C</sub> (Min) = 120 MSPS in this mode.

**Straight Mode (See Application Circuits, Figures 21, 22, 23)**

Set the SELECT pin to GND for this mode. In this mode, data output can be obtained in accordance with the clock frequency applied to the A/D converter for applications which use the clock applied to the A/D converter as the system clock.

The A/D converter can operate at  $f_C$  (Min) = 100 MSPS in this mode.

**Digital Input Level and Supply Voltage Settings**

The logic input level for the HI3026 supports ECL, PECL and TTL levels.

The power supplies ( $DV_{EE3}$ ,  $DGND3$ ) for the logic input block must be set to match the logic input (CLK and RESET signals) level.

TABLE 3. LOGIC INPUT LEVEL AND POWER SUPPLY SETTINGS

DIGITAL INPUT LEVEL	$DV_{EE3}$	$DGND3$	SUPPLY VOLTAGE	APPLICATION CIRCUITS
ECL	-5V	0V	5V	Figures 18, 21
PECL	0V	+5V	+5V	Figures 19, 22
TTL	0V	+5V	+5V	Figures 20, 23

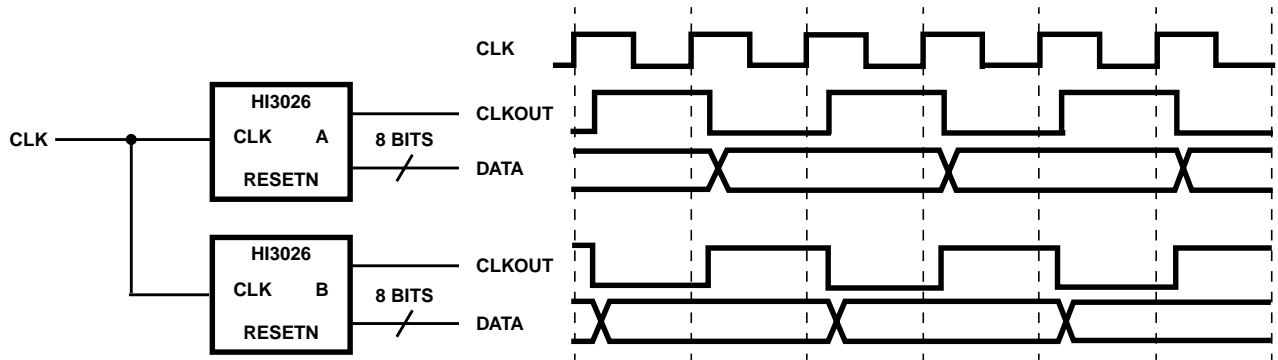

FIGURE 9. WHEN THE RESET PULSE IS NOT USED

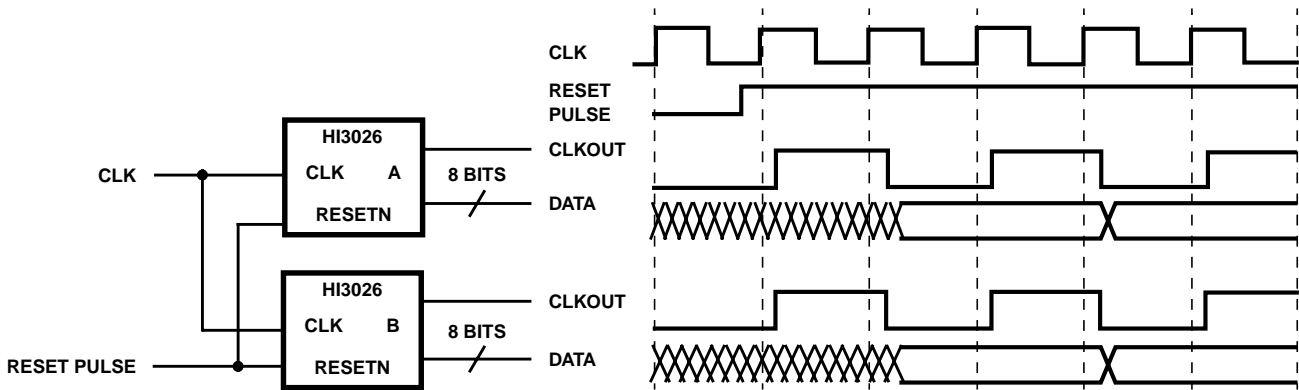

FIGURE 10. WHEN THE RESET PULSE IS USED

**Typical Performance Curves**

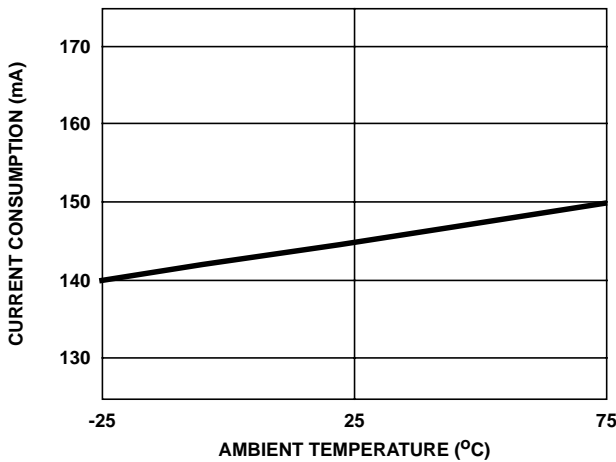

FIGURE 11. CURRENT CONSUMPTION vs AMBIENT TEMPERATURE CHARACTERISTICS

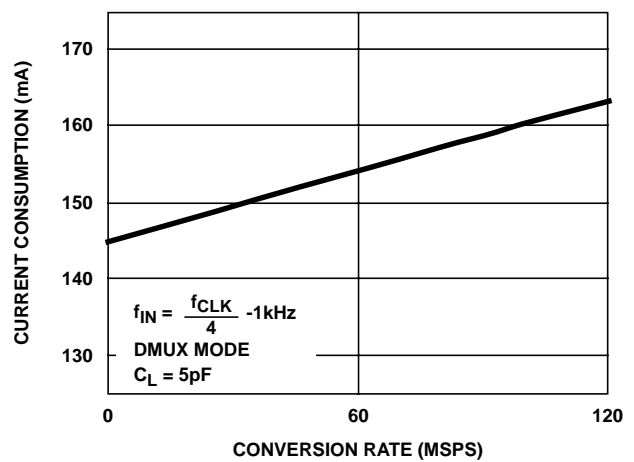

FIGURE 12. CURRENT CONSUMPTION vs CONVERSION RATE CHARACTERISTICS RESPONSE

Typical Performance Curves (Continued)

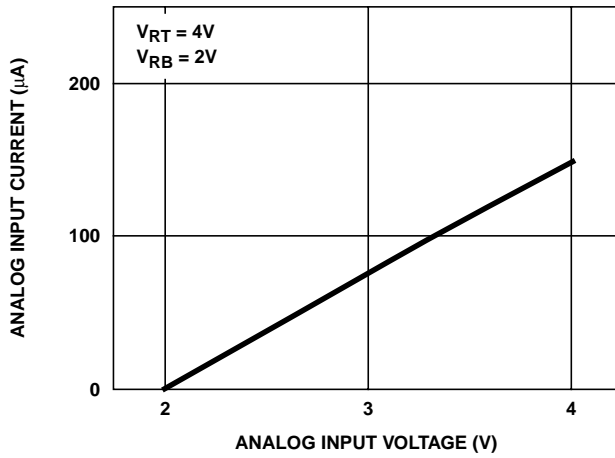

FIGURE 13. ANALOG INPUT CURRENT vs ANALOG INPUT VOLTAGE CHARACTERISTICS

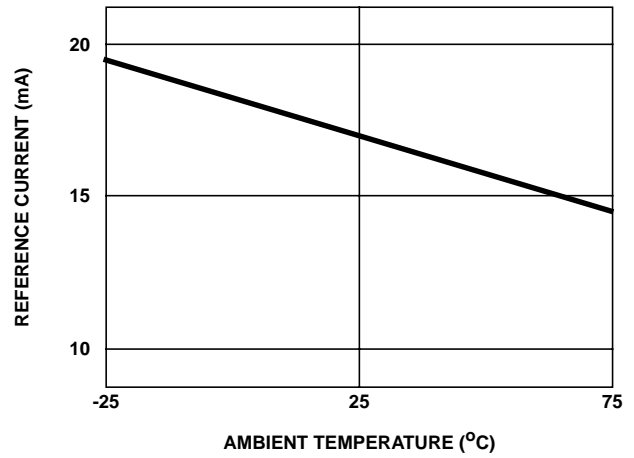

FIGURE 14. REFERENCE CURRENT vs AMBIENT TEMPERATURE CHARACTERISTICS

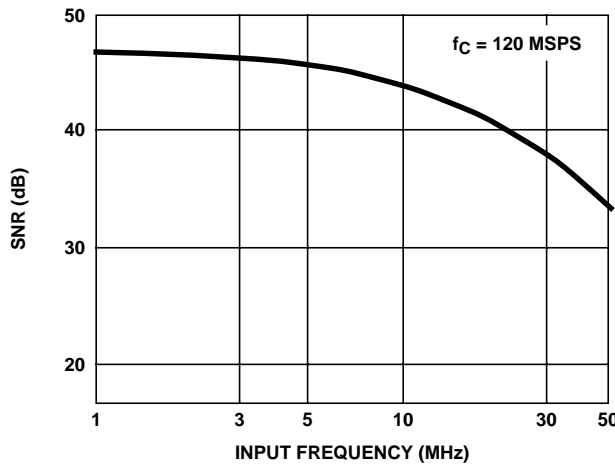

FIGURE 15. SNR vs INPUT FREQUENCY RESPONSE

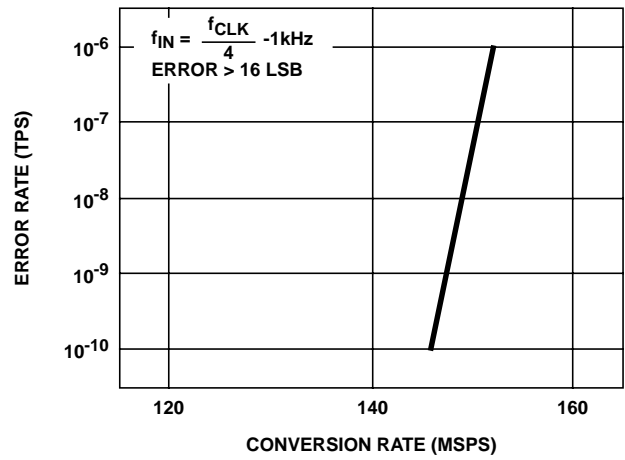

FIGURE 16. ERROR RATE vs CONVERSION RATE CHARACTERISTICS

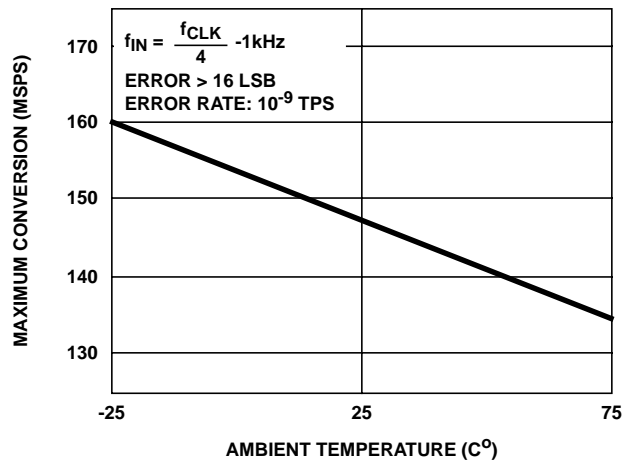

FIGURE 17. MAXIMUM CONVERSION RATE vs AMBIENT TEMPERATURE CHARACTERISTICS

Application Circuits

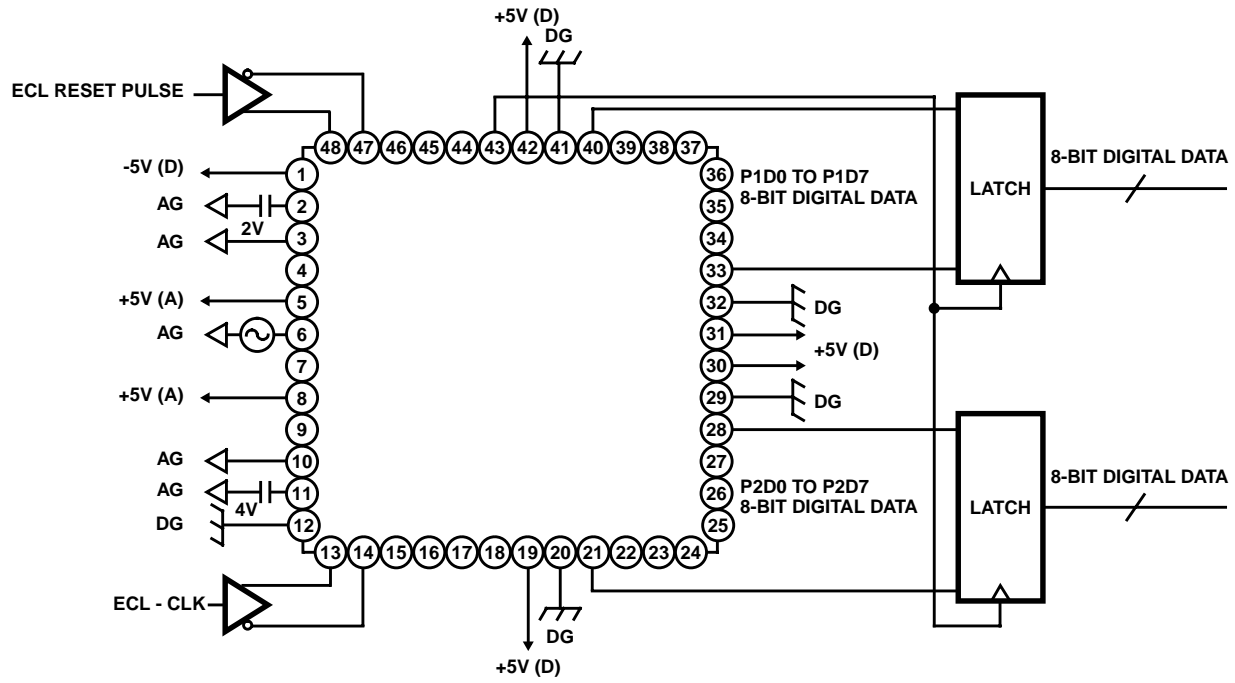

FIGURE 18. DMUX ECL INPUT

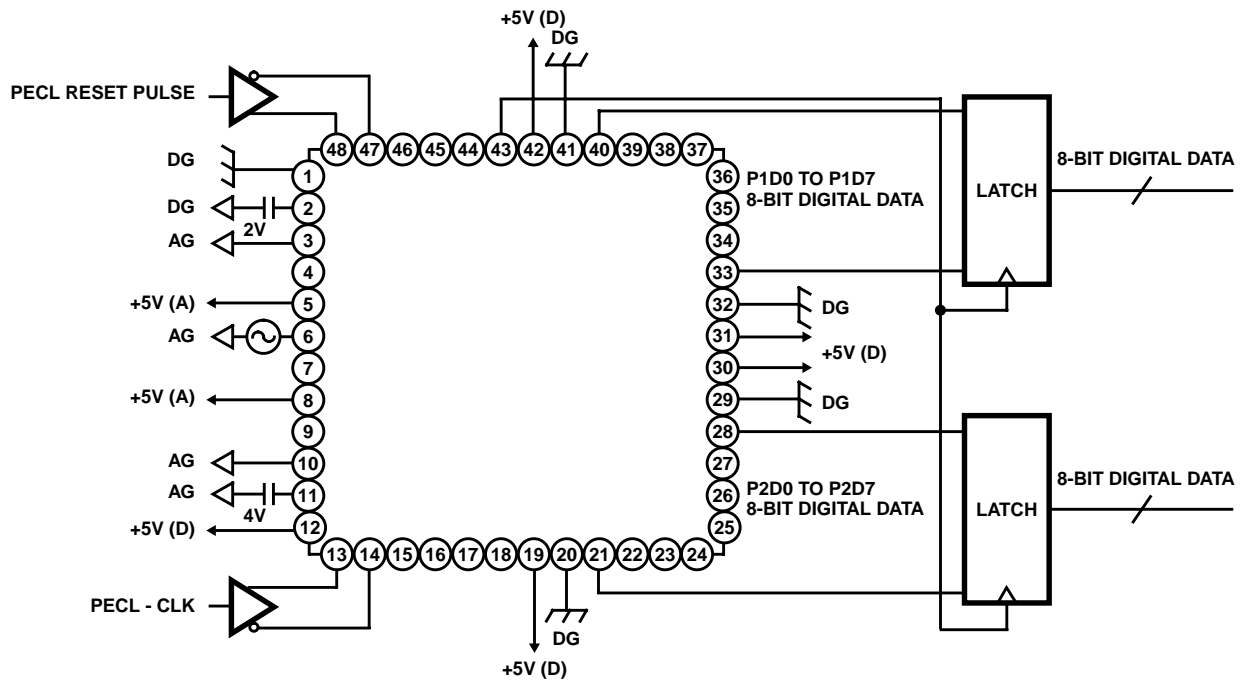

FIGURE 19. DMUX PECL INPUT

Application Circuits (Continued)

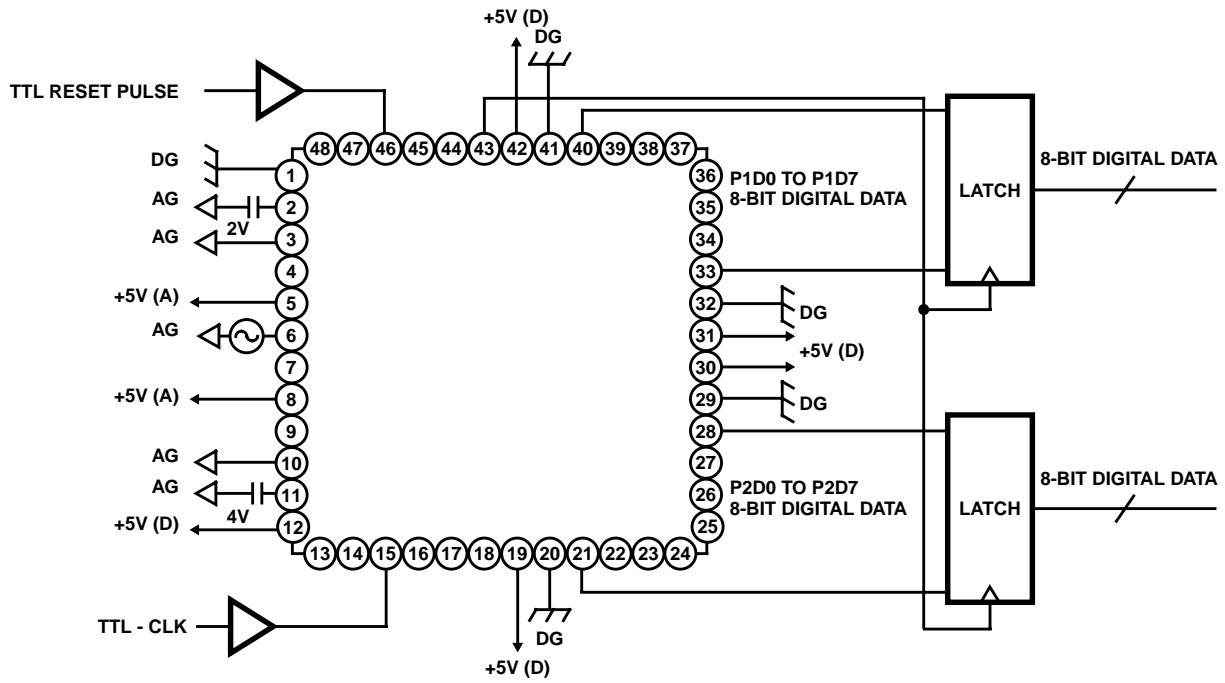

FIGURE 20. DMUX TTL INPUT

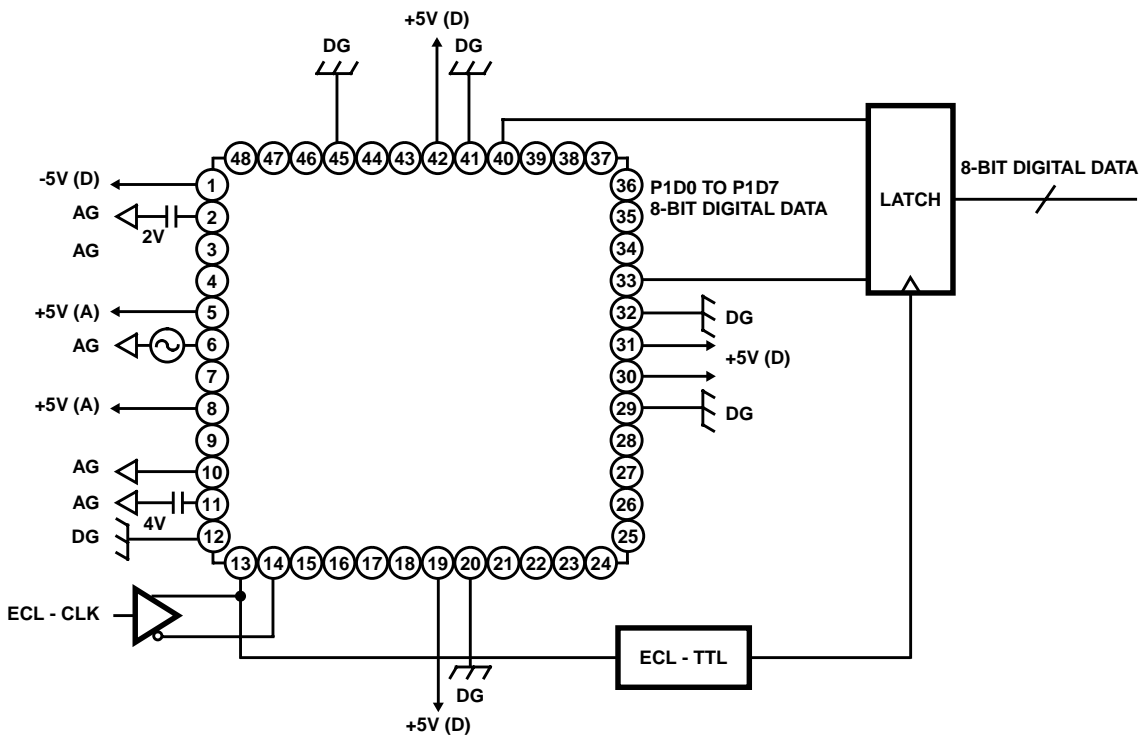

FIGURE 21. STRAIGHT ECL INPUT

Application Circuits (Continued)

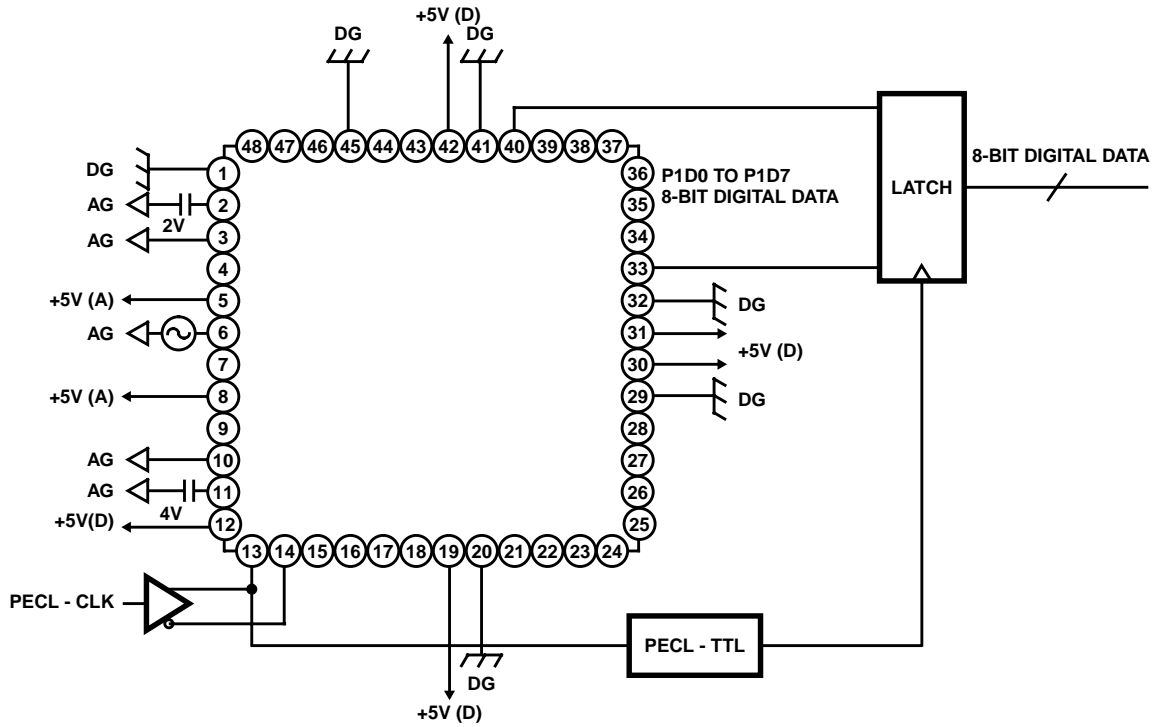

FIGURE 22. STRAIGHT PECL INPUT

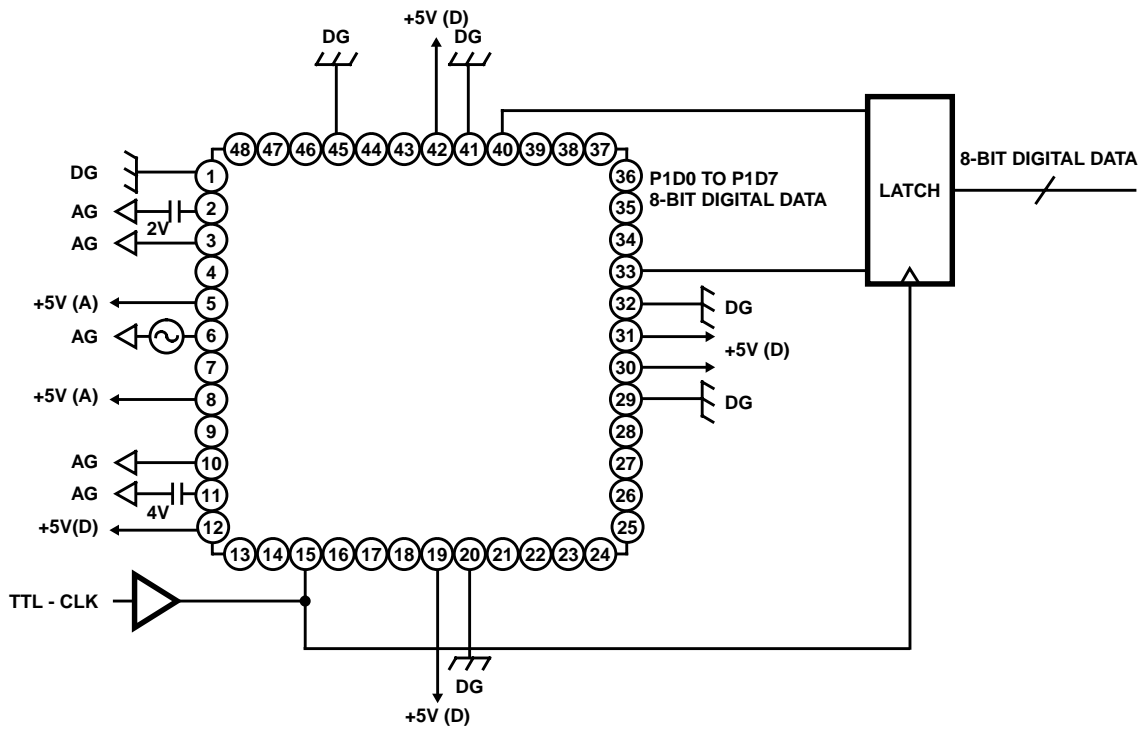

FIGURE 23. STRAIGHT TTL INPUT

Application Circuits (Continued)

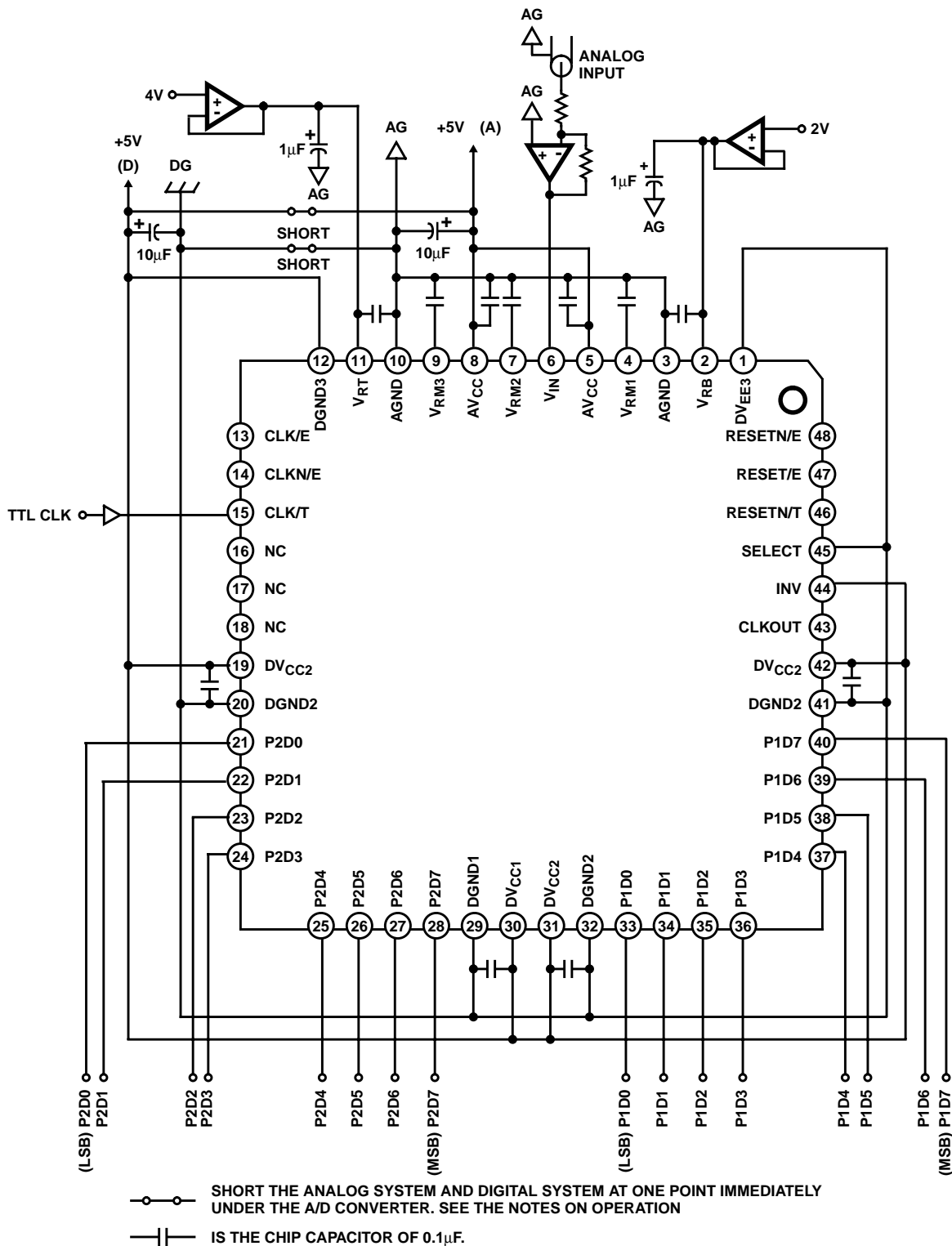

FIGURE 24. STRAIGHT MODE TTL I/O (WHEN A SINGLE POWER SUPPLY IS USED)



All Intersil semiconductor products are manufactured, assembled and tested under **ISO9000** quality systems certification.

*Intersil products are sold by description only. Intersil Corporation reserves the right to make changes in circuit design and/or specifications at any time without notice. Accordingly, the reader is cautioned to verify that data sheets are current before placing orders. Information furnished by Intersil is believed to be accurate and reliable. However, no responsibility is assumed by Intersil or its subsidiaries for its use; nor for any infringements of patents or other rights of third parties which may result from its use. No license is granted by implication or otherwise under any patent or patent rights of Intersil or its subsidiaries.*

For information regarding Intersil Corporation and its products, see web site <http://www.intersil.com>

### **Sales Office Headquarters**

#### **NORTH AMERICA**

Intersil Corporation  
P. O. Box 883, Mail Stop 53-204  
Melbourne, FL 32902  
TEL: (321) 724-7000  
FAX: (321) 724-7240

#### **EUROPE**

Intersil SA  
Mercure Center  
100, Rue de la Fusee  
1130 Brussels, Belgium  
TEL: (32) 2.724.2111  
FAX: (32) 2.724.22.05

#### **ASIA**

Intersil (Taiwan) Ltd.  
Taiwan Limited  
7F-6, No. 101 Fu Hsing North Road  
Taipei, Taiwan  
Republic of China  
TEL: (886) 2 2716 9310  
FAX: (886) 2 2715 3029