



Shenzhen HB Science & Technology Co., Ltd

zhren

Inspection Specification

To :
Date :

CPT TFT-LCD

CLAA170EA03

ACCEPTED BY :

APPROVED BY	CHECKED BY	PREPARED BY
		TFT-LCD Plant Application Div.

**Prepared by : Product Planning Management General Division TFT Business Unit
Shenzhen HB Science & Technology Co., Ltd**

BLOCK 1, LONGWU INDUSTRIAL ESTATE
SHANGTANG VILLEGE, LONGHUA TOWN
BAOAN DISTRICT, SHENZHEN CITY
GUANG TONG PROVINCE, P.R.CHINA

TEL: +86-755-28115516 FAX: +86-755-28115795

Doc.No:		Issue Date:	
---------	--	-------------	--

1. OVERVIEW

CLAA170EA03 is 17" color TFT-LCD (Thin Film Transistor Liquid Crystal Display) module composed of LCD panel, RSDS driver ICs, control circuit and backlight.

By applying 6 bit digital data, 1280 x1024, 262K color(6Bit) images are displayed on the 17.0" diagonal screen. Input power voltage is 12.0V for LCD driving. Inverter for backlight is not included in this module. General specification are summarized in the following table:

ITEM	SPECIFICATION
Display Area(mm)	337.920 (H)x270.336 (V) (17.0-inch diagonal)
Number of Pixels	1280(H)x1024(V)
Pixel Pitch(mm)	0.264(H)x0.264(V)
Color Pixel Arrangement	RGB vertical stripe
Display Mode	normally white, TN
Number of Colors	262144colors(6bit)
Brightness(cd/m ²)	300cd/m ² (Typ.)(Center point,lamp current:7mA)
Viewing Angle	140/130(Typ.)
Wide Viewing Angle Technology	Optical Compensation Film
Surface Treatment	Anti-glare
Electrical Interface	RSDS (2 pixel/clock)
Total Module Power(W)	20(Typ.)
Optimum Viewing Angle	6 o'clock
Module Size(mm)	358.5(W)x296.5(H)x17.0(D)
Module Weight(g)	1800(typ.)
Backlight Unit	CCFL, 4 tables, edge-light(top*2/bottom*2)

The LCD Products listed on this document are not suitable for use of aerospace equipment, submarine cables, nuclear reactor control system and life support systems. If customers intend to use these LCD products for above application or not listed in "Standard" as follows, please contact our sales people in advance.

Standard: Computer, Office equipment, Communication equipment, Test and Measurement equipment, Machine tool, Industrial robot, Audio and Visual equipment, Other consumer products.

2. ABSOLUTE MAXIMUM RATINGS

ITEM	SYMBOL	MIN.	MAX.	UNIT
Power Supply Voltage for LCD	VCC	-0.3	20.0	V
Logic Input Voltage	VDD	-0.3	5.0	V
Static Electricity	VESDt	-200	200	V
	VESDc	-8000	8000	V
ICC Rush Current	IRUSHc	-	3.0	A
IDD Rush Current	IRUSHd	-	0.75	A
Lamp Voltage	VL	0	2500	Vrms
Lamp Current	IL	0	10.0	mA rms
Lamp Frequency	FL	-	100	kHz
Operation Temperature	T _{op}	0	50	
Storage Temperature	T _{stg}	-20	60	

Note: Test Condition: IEC 1000-4-2 ,

VESDt : Contact discharge to input connector

VESDc : Contact discharge to module

50 μ sec , If Vcc rise time increase then I_{RUSH} decrease.

Humidity :

Humidity 85%RH without condensation.

Relative Humidity 95% (Ta 40)

Wet Bulb Temperature 39 (Ta 40)

T_{op}、T_{stg} Humidity 40 : Relative Humidity 90 % RH without condensation.

T_{op}、T_{stg} Humidity > 40 :40 , Absolute Humidity 90 % RH without condensation.

3. ELECTRICAL CHARACTERISTICS

(a)TFT-LCD

ITEM	SYMBOL	MIN	TYP	MAX	UNIT	Remark
Power Supply Voltage for Logic	VDDD	3.0	3.3	3.6	V	
Power Supply Current for Logic	IDDD	--	40	100	mA	
Permissive Ripple Voltage for Logic	VDRP	--	--	30	mVp-p	V=+3.3V
Power Supply Voltage	VCC	10.8	12.0	13.2	V	
Power Supply Current	ICC	--	100	250	mA	
Permissive Ripple Voltage	VCRP	-	-	100	mVp-p	V=+12.0V
Differential impedance	Zm	90	100	110		
Input Threshold Voltage	High	VIH	2.5	3.3	V	
	Low	VIL	0	--	0.8	V

[Note 1]

Power sequence

0<T1、 T4、 T5、 T6 10ms

0<T2 20ms ; 200ms T3

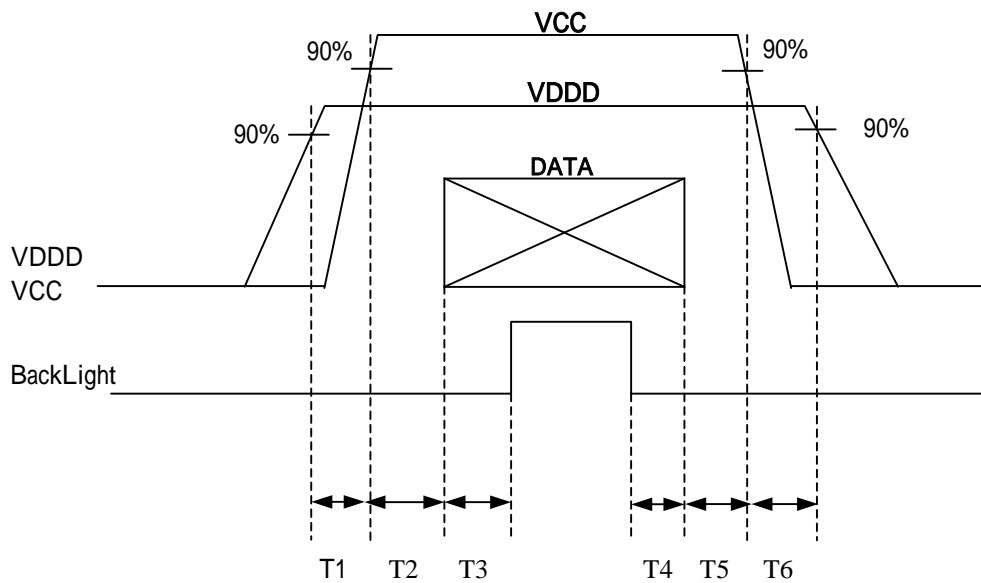

VCC-dip conditions

1)When 8.64V $V_{in(min)} < 10.8V$

t_d 10 ms

2)When $VCC < 8.64V$

VCC-dip conditions should also follow the VCC-turn-on conditions.

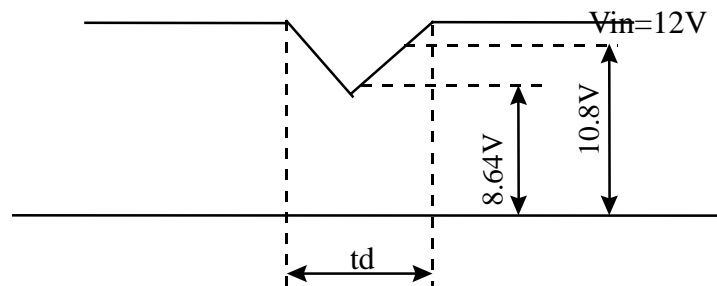

[Note 2] Typical current situation : 64-gray-bar pattern, 1280 line mode

$VCC = 12.0V$, $f_H = 64kHz$, $f_V = 60Hz$, $f_{CLK} = 54MHz$

$VDDD = 3.3V$, $f_H = 64kHz$, $f_V = 60Hz$, $f_{CLK} = 54MHz$

(b) Backlight

ITEM	SYMBOL	MIN	TYP	MAX	UNIT	REMARK
Lamp Voltage	VL	--	710	--	V	IL=7.0mA
Lamp Current	IL	5.0	7.0	8.0	mA	Note1
Interter Frequency	FL	45	50	70	kHz	Note2
Starting Lamp Voltage	VS	1350	-	-	V	Tb=0 , Note3
		1080	-	-	V	Ta=25 , Note3
Lamp life Time	LT	--	50,000	--	hr	IL=6.0mA Continuous Operation
		--	40,000	--	hr	IL=7.0mA Continuous Operation

[Note 1] Lamp Current measurement method (The current meter is inserted in cold line)

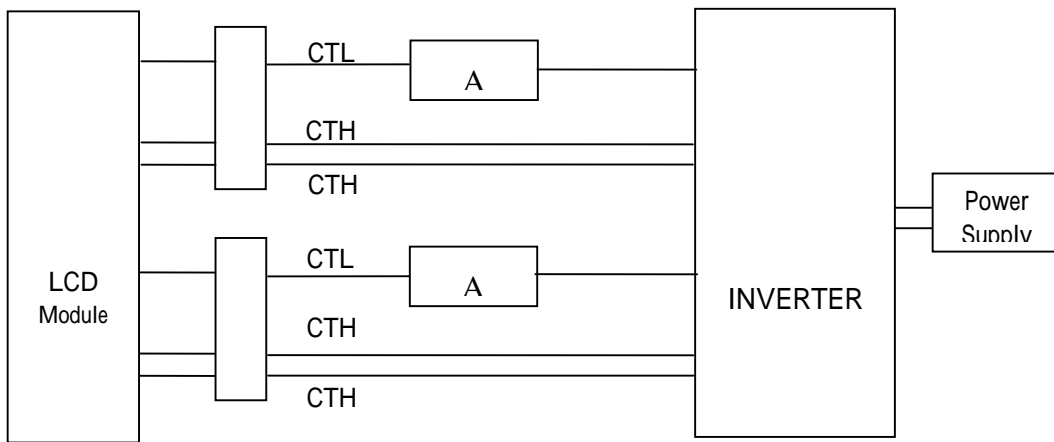

[Note 2] Lamp frequency of inverter may produce interference with horizontal synchronous frequency, and this may cause horizontal beat on the display. Therefore, please adjust lamp frequency, and keep inverter as far from module as possible or use electronic shielding between inverter and module to avoid the interference.

The degrees of unbalance: less than 10%
 The ratio of wave height: less than $2 \pm 10\%$

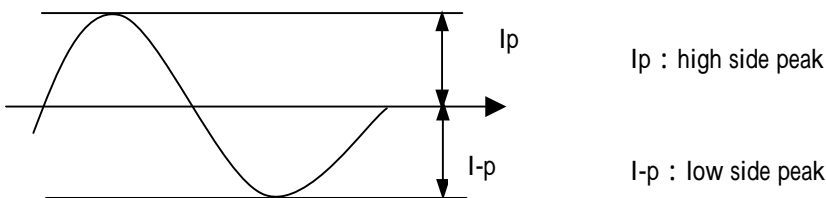

A : The degrees of unbalance = $| I_p - I-p | / I_{rms} \times 100 (\%)$
 B : The ratio of wave height = I_p (or $I-p$) / I_{rms}

[Note 3]
 Definition of the lamp life time
 Luminance: L under 50% of specification

(C) RSDS CHARACTERISTICS

ITEM	SYMBOL	CONDICTION	MIN	TYP	MAX	UNIT
RSDS Input high voltage high level	VIHRSDS	VCMRSDS=+1.2V	100	200	-	mV
RSDS Input high voltage low level	VILRSDS	VCMRSDS=+1.2V	-	-200	-100	mV
RSDS common mode Input voltage range	VCMRSDS	VDIFFRSDS ⁽²⁾ = 200 mV (minimum value)	1.0	-	1.4	V
RSDS leakage of input current	IDL	DxxP, DxxN, CLKP, CLKN	-10	-	10	uA

[Note]

- $VCM_{RSDS} = (VCLKP + VCLKN) / 2$ or $VCM_{RSDS} = (VDxxP + VDxxN) / 2$
- $VDIFF_{RSDS} = VCLKP - VCLKN$ or $VDIFF_{RSDS} = VDxxP - VDxxN$

RSDS Standard V-p to Vp value is 400mV from -200mV to +200mV.

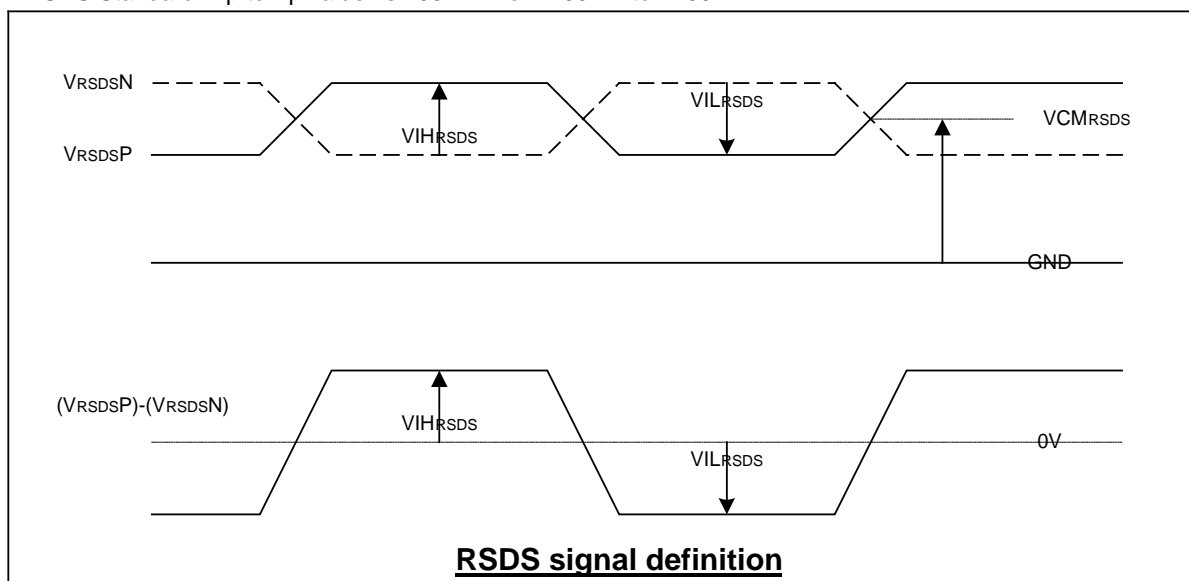

4. INTERFACE PIN CONNECTION

(a)CN1(Data Signal and Power Supply)

Used connector:IL-FHR-B30S-HF(JAE)

PIN NO.	symbol	Function
1	GND	Ground
2	B2P_B	RSDS Blue Data(+)(Back side)
3	B2N_B	RSDS Blue Data(-)(Back side)
4	GND	Ground
5	B1P_B	RSDS Blue Data(+)(Back side)
6	B1N_B	RSDS Blue Data(-)(Back side)
7	GND	Ground
8	B0P_B	RSDS Blue Data(+)(Back side)
9	B0N_B	RSDS Blue Data(-)(Back side)
10	GND	Ground
11	G2P_B	RSDS Green Data (+)(Back side)
12	G2N_B	RSDS Green Data (-)(Back side)
13	GND	Ground
14	G1P_B	RSDS Green Data (+)(Back side)
15	G1N_B	RSDS Green Data (-)(Back side)
16	GND	Ground
17	G0P_B	RSDS Green Data (+)(Back side)
18	G0N_B	RSDS Green Data (-)(Back side)
19	GND	Ground
20	CLKP_B	Source Driver IC RSDS CLK (+)(Back side)
21	CLKN_B	Source Driver IC RSDS CLK (-)(Back side)
22	GND	Ground
23	R2P_B	RSDS Red Data (+)(Back side)
24	R2N_B	RSDS Red Data (-)(Back side)
25	GND	Ground
26	R1P_B	RSDS Red Data (+)(Back side)
27	R1N_B	RSDS Red Data (-)(Back side)
28	GND	Ground
29	R0P_B	RSDS Red Data (+)(Back side)
30	R0N_B	RSDS Red Data (-)(Back side)

(b)CN2 Used connector: IL-FHR-B50S-HF(JAE)

Pin NO.	symbol	Function
1	GND	Ground
2	B2P_F	RSDS Blue Data(+)(Front side)
3	B2N_F	RSDS Blue Data(-)(Front side)
4	GND	Ground
5	B1P_F	RSDS Blue Data(+)(Front side)
6	B1N_F	RSDS Blue Data(-)(Front side)
7	GND	Ground
8	B0P_F	RSDS Blue Data(+)(Front side)
9	B0N_F	RSDS Blue Data(-)(Front side)
10	GND	Ground
11	G2P_F	RSDS Green Data (+)(Front side)
12	G2N_F	RSDS Green Data (-)(Front side)
13	GND	Ground
14	G1P_F	RSDS Green Data (+)(Front side)
15	G1N_F	RSDS Green Data (-)(Front side)
16	GND	Ground
17	G0P_F	RSDS Green Data (+)(Front side)
18	G0N_F	RSDS Green Data (-)(Front side)
19	GND	Ground
20	CLKP_F	Source Driver IC RSDS CLK (+)(Front side)

21	CLKN_F	Source Driver IC RSDS CLK (-)(Front side)
22	GND	Ground
23	R2P_F	RSDS Red Data (+)(Front side)
24	R2N_F	RSDS Red Data (-)(Front side)
25	GND	Ground
26	R1P_F	RSDS Red Data (+)(Front side)
27	R1N_F	RSDS Red Data (-)(Front side)
28	GND	Ground
29	R0P_F	RSDS Red Data (+)(Front side)
30	R0N_F	RSDS Red Data (-)(Front side)
31	GND	Ground
32	STH_F	Source Driver IC Start pulse(Front side)
33	LP	Source Driver IC Latch Pulse
34	POL	Source Driver M signal
35	STH_B	Source Driver IC Start pulse(Back side)
36	GND	Ground
37	CLKV	
38	STV	Gate Driver IC Start pulse
39	OE	Gate Driver IC Output Enable
40	VCOM(test)	N.C.
41	GND	Ground
42	3.3V	Power Supply Voltage for Logic
43	3.3V	Power Supply Voltage for Logic
44	12V	LCD Power Supply
45	GND	Ground
46	12V	LCD Power Supply
47	12V	LCD Power Supply
48	12V	LCD Power Supply
49	NC	NC
50	NC	NC

(C)CN3,4(BACKLIGHT)

Backlight-side connector: BHR-04VS-1(JST)

Inverter-side connector: SM04(4.0)B-BHS-1-TB(JST)

Pin No.	Symbol	Function
1	CTH1	VBLH1(HIGH VOLTAGE)
2	CTH2	VBLH2(HIGH VOLTAGE)
3	-	-
4	CTL1	VBLL(LOW VOLTAGE)

[Note]

VBLH-VBLL = VL

5. INTERFACE TIMING

(a) Timing Specifications

Item		Symbol	Min	Typ	Max	Unit	
LCD Timing	DCLK	Frequenc	f_{CLK}	41.6	54	67.5	MHz
		period	t_{CLK}	14.8	18.5	24	ns

Horizontal signal:

Item	Symbol	Min	Typ	Max	Unit
CLK pulse width	T_w	14	18.5	24	ns
CLK pulse width	T_{wh}	6	-	-	ns
CLK pulse width	T_{wl}	6	-	-	ns
DATA set-up time	T_{st1}	4	-	-	ns
DATA hold time	T_{hd1}	0.2	-	-	ns
STH set-up time	T_{st2}	4	-	-	ns
STH hold time	T_{hd2}	4	-	-	ns
STH pulse width	T_{wsth}	1	1	2	CLKP period
LP pulse width (H)	T_{wlp}	(48)	-	(53)	CLKP period
LP to STH setup time	T_{lp-sth}	5	-	-	CLKP period
Last data time	T_{ldt}	1	-	-	CLKP period
CLK-LP time	T_{clk-lp}	4	-	-	ns
LP-POL time	T_{lp-pol}	(640)	-	(784)	CLKP period
POL-LP time	T_{pol-lp}	(7)	-	(30)	CLKP period

Vertical signal:

Item	Symbol	MIN	TYP	MAX	Unit
STV set-up time	$t_{st}(STV)$	1	-	-	μs
STV hold time	$t_{hd}(STV)$	1	-	-	μs
CLKV period	$t_w(CLKV)$	8	-	-	μs
CLKV High width	$t_{wH}(CLKV)$	3.5	-	-	μs
CLKV Low width	$t_{wL}(CLKV)$	3.5	-	-	μs
OE pulse width	$T_w(OE)$	2.4	2.9	3.4	μs
OE-CLKV time	$t_{OE-CLKV}$	1.5	2	3	μs
LP rise-CLKV rise time	$t_{LP-CLKV}$	0	0	0	ns

(b) Timing Chart

a. Horizontal Timing Chart
Timing Diagram 1

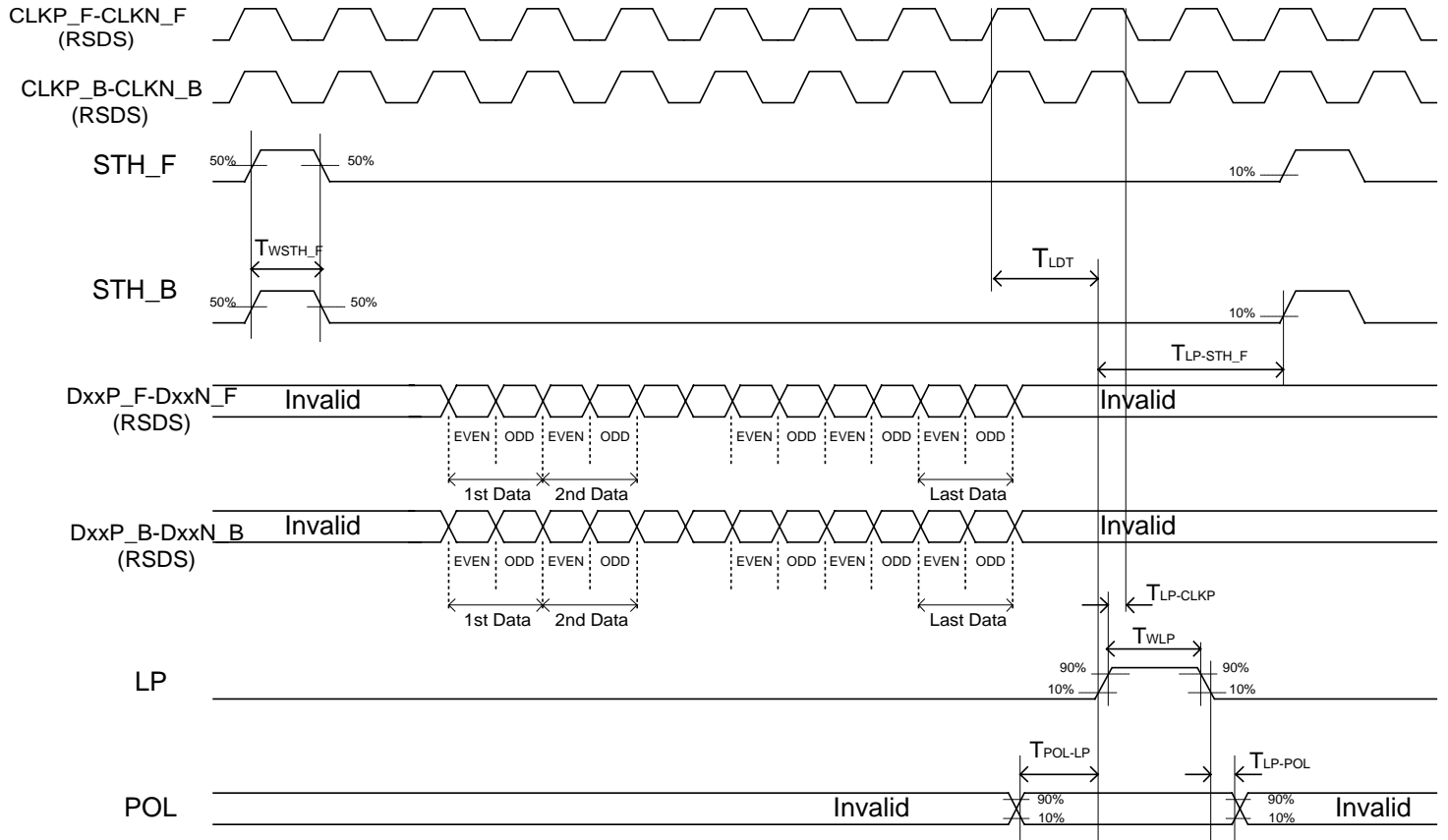

Timing Diagram 2

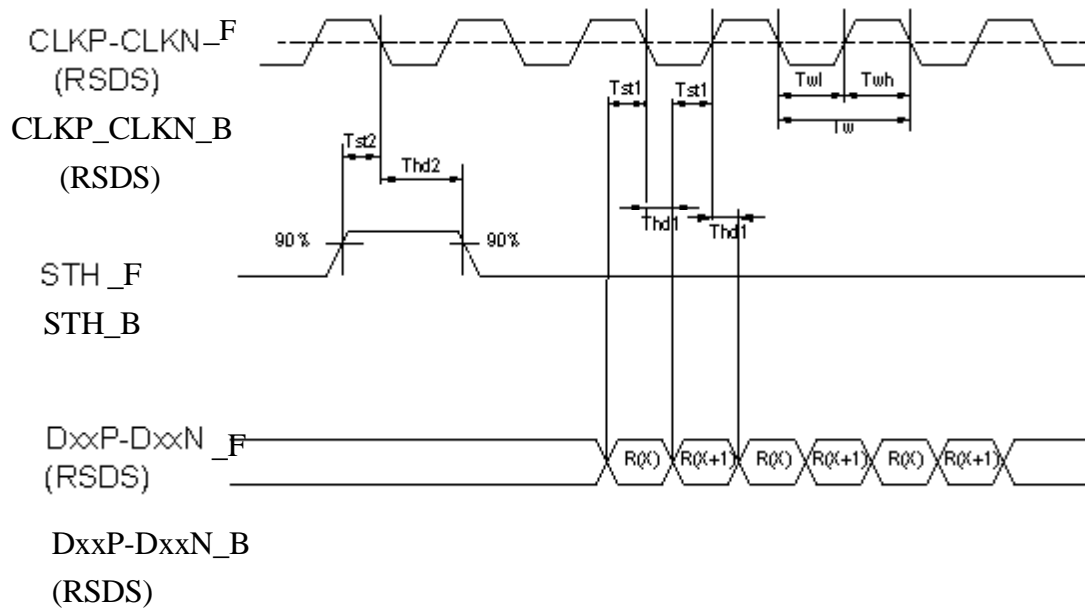

b. Vertical Timing Chart

Vertical Signal 1

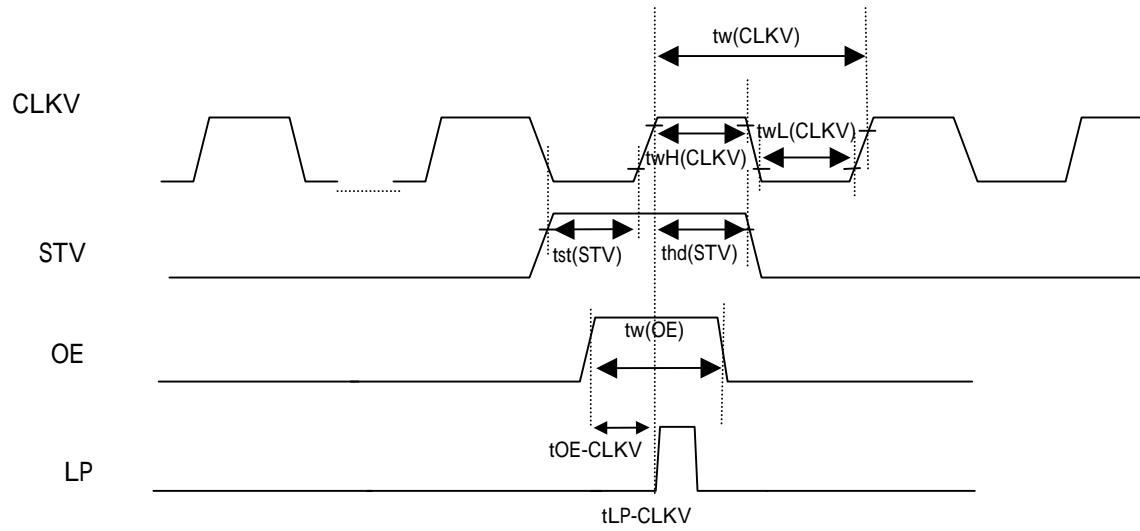

[Note] : STV、CLKV output signal specifications level is $V_{OL(\text{MAX})}=80\%$ 、 $V_{OH(\text{MIN})}=20\%$.

c. Color Data Assignment

COLOR	INPUT DATA	R DATA						G DATA						B DATA				
		R5 MSB	R4	R3	R2	R1	R0 LSB	G5 MSB	G4	G3	G2	G1	G0 LSB	B4	B3	B2	B1	B0 LSB
BASIC COLOR	BLACK	0	0	0	0	0	0	0	0	0	0	0	0	0	0	0	0	0
	RED(63)	1	1	1	1	1	1	0	0	0	0	0	0	0	0	0	0	0
	GREEN(63)	0	0	0	0	0	0	1	1	1	1	1	1	0	0	0	0	0
	BLUE(63)	0	0	0	0	0	0	0	0	0	0	0	0	1	1	1	1	1
	CYAN	0	0	0	0	0	0	1	1	1	1	1	1	1	1	1	1	1
	MAGENTA	1	1	1	1	1	1	0	0	0	0	0	0	1	1	1	1	1
	YELLOW	1	1	1	1	1	1	1	1	1	1	1	1	0	0	0	0	0
	WHITE	1	1	1	1	1	1	1	1	1	1	1	1	1	1	1	1	1
RED	RED(0)	0	0	0	0	0	0	0	0	0	0	0	0	0	0	0	0	0
	RED(1)	0	0	0	0	0	1	0	0	0	0	0	0	0	0	0	0	0
	RED(2)	0	0	0	0	1	0	0	0	0	0	0	0	0	0	0	0	0
	RED(62)	1	1	1	1	1	0	0	0	0	0	0	0	0	0	0	0	0
	RED(63)	1	1	1	1	1	1	0	0	0	0	0	0	0	0	0	0	0
GREEN	GREEN(0)	0	0	0	0	0	0	0	0	0	0	0	0	0	0	0	0	0
	GREEN(1)	0	0	0	0	0	0	0	0	0	0	0	1	0	0	0	0	0
	GREEN(2)	0	0	0	0	0	0	0	0	0	0	1	0	0	0	0	0	0
	GREEN(62)	0	0	0	0	0	0	1	1	1	1	1	0	0	0	0	0	0
	GREEN(63)	0	0	0	0	0	0	1	1	1	1	1	1	0	0	0	0	0
BLUE	BLUE(0)	0	0	0	0	0	0	0	0	0	0	0	0	0	0	0	0	0
	BLUE(1)	0	0	0	0	0	0	0	0	0	0	0	0	0	0	0	0	1
	BLUE(2)	0	0	0	0	0	0	0	0	0	0	0	0	0	0	0	1	0
	BLUE(62)	0	0	0	0	0	0	0	0	0	0	0	0	1	1	1	1	0
	BLUE(63)	0	0	0	0	0	0	0	0	0	0	0	0	1	1	1	1	1

[Note]

- (1) Definition of gray scale:
 Color(n) : n indicates gray scale level.
 Higher n means brighter level.
- (2) Data: 1-High, 0-Low.

(d) Color Data Assignment

D(1,1)	D(2,1)	..	D(X,1)	..	D(1280,1)
D(1,2)	D(2,2)	..	D(X,2)	..	D(1280,2)
..	..	+	..	+	..
D(1,Y)	D(2,Y)	..	D(X,Y)	..	D(1279,Y) D(1280,Y)
..	..	+	..	+	..
D(1,1023)	D(2,1023)	..	D(X,1023)	..	D(1279,1023)
D(1,1024)	D(2,1024)	..	D(X,1024)	..	D(1279,1024)

6. BLOCK DIAGRAM

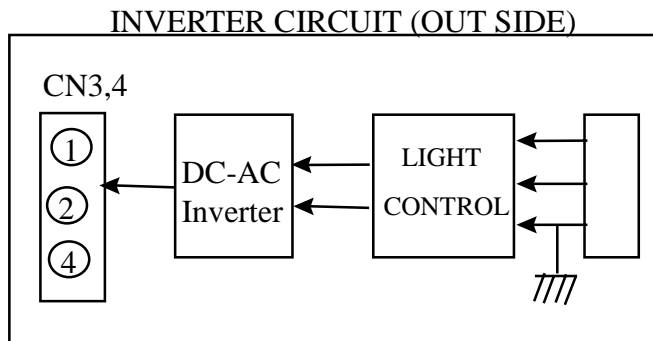
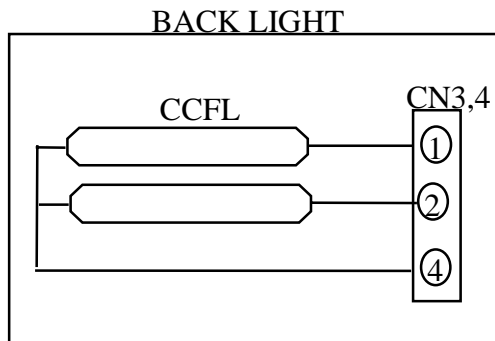
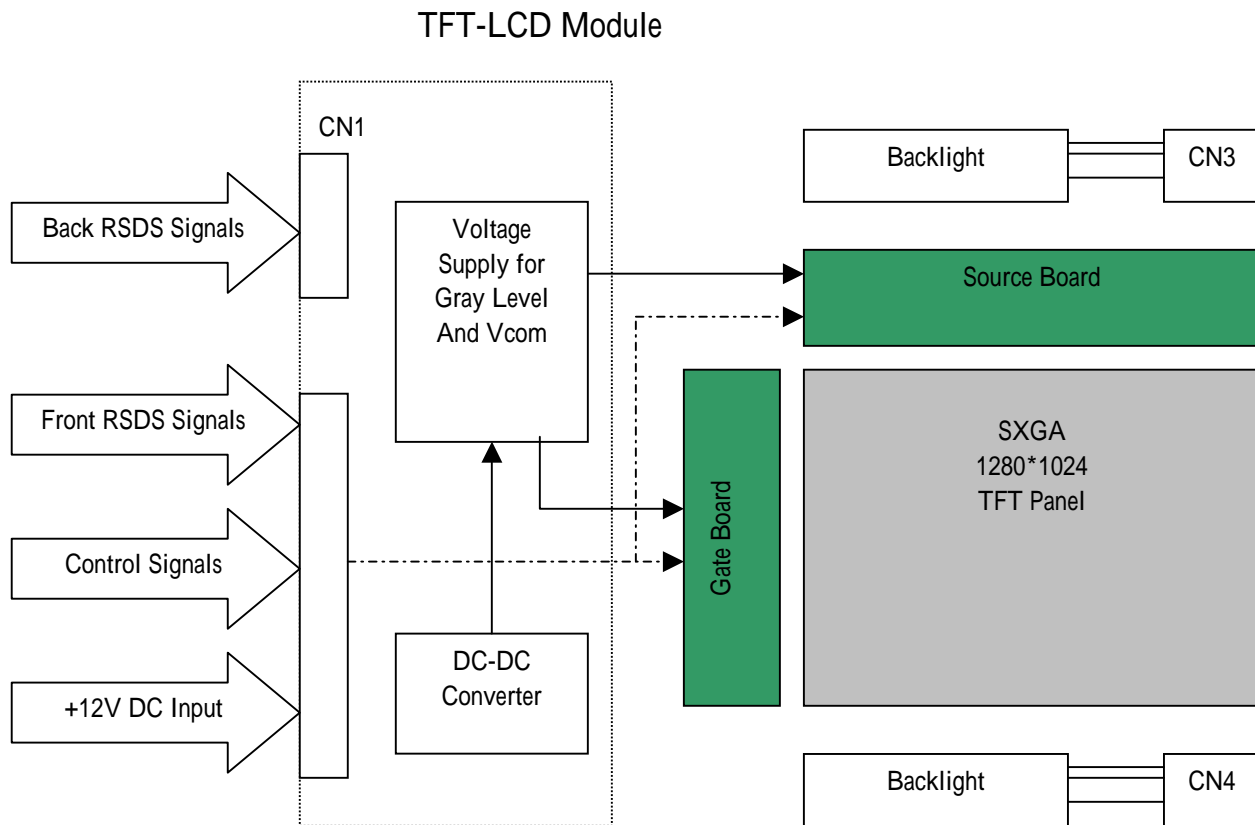

7. MECHANICAL SPECIFICATION

(a) Front side

Unit: mm

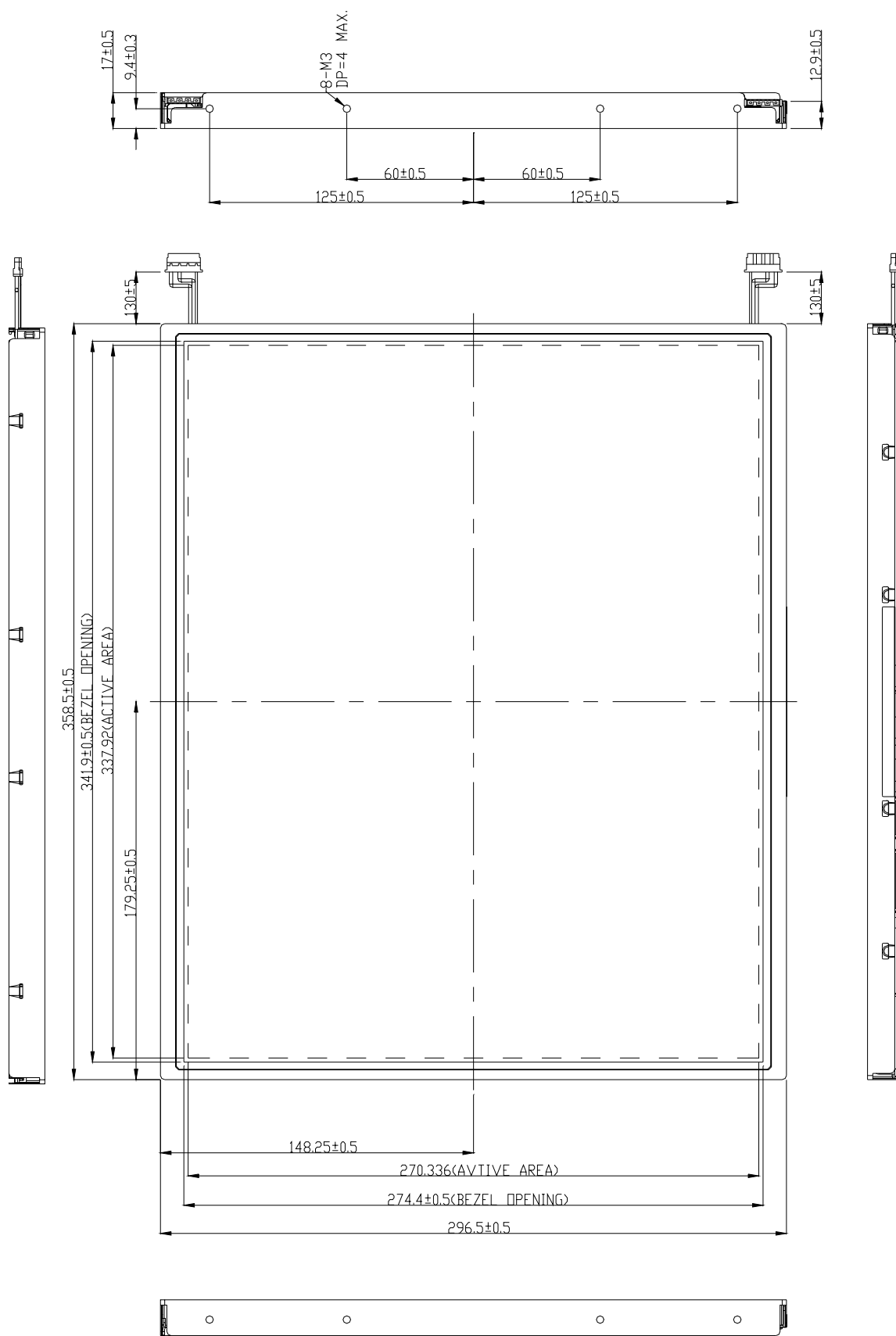

Tolerance is ± 0.5 mm unless noted

(b) Rear side

Unit: mm

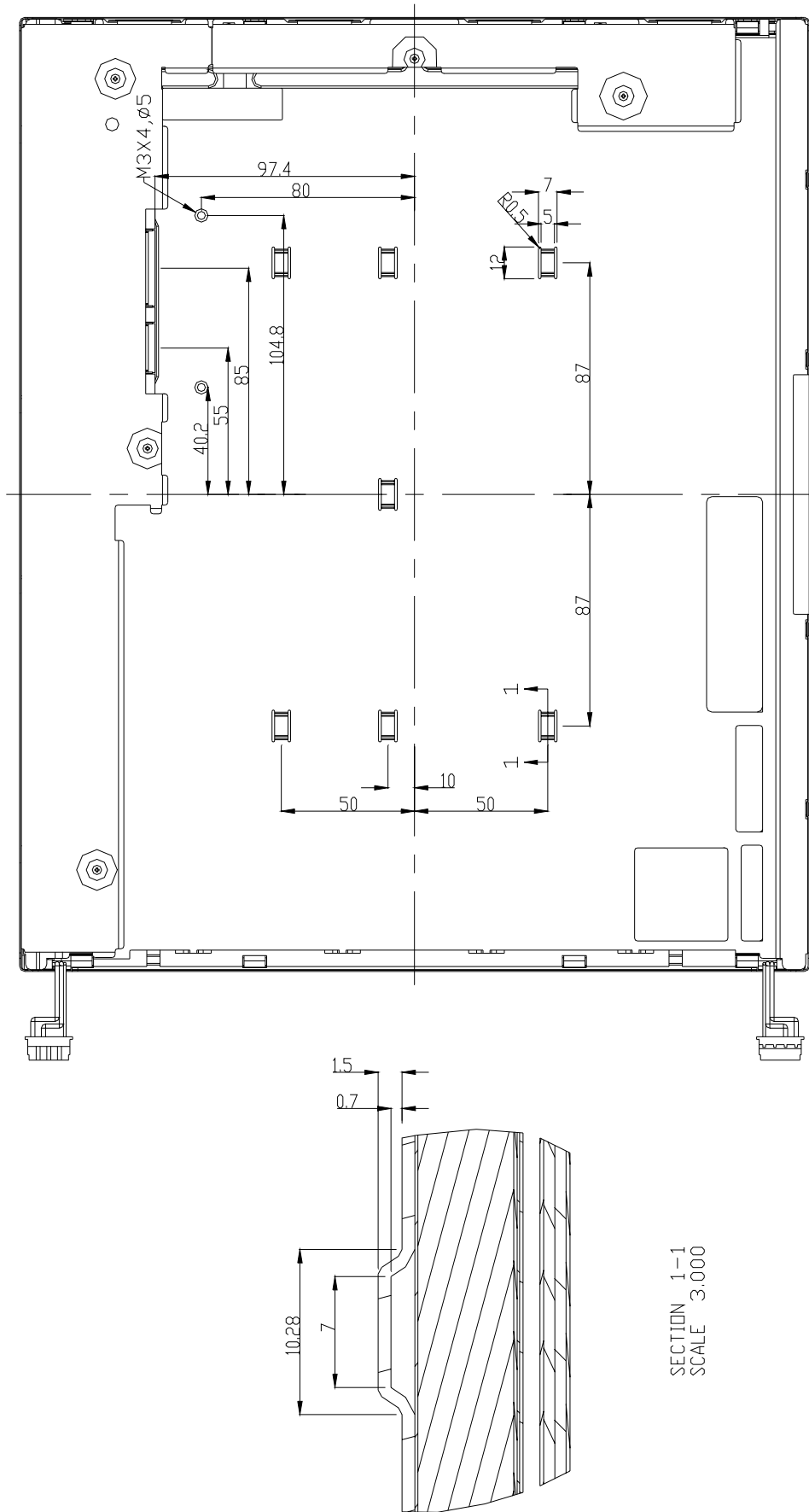

Tolerance is ±0.5mm unless noted

8.OPTICAL CHARACTERISTICS

Ta = 25°C , Vcc=12.0V

ITEM	SYMBOL	CONDITION	MIN.	TYP.	MAX.	UNIT		
Contrast Ratio	CR	$\theta = 0^\circ$	360	450	--	--		
Luminance	Center	L	$\theta = 0^\circ$	240	300	--	cd/m ²	
	5 point	Normal	L	$\theta = 0^\circ$	230	285	--	
		Uniformity	ΔL	$\theta = 0^\circ$	--	--	15	%
	9 point	Normal	L	$\theta = 0^\circ$	220	275	--	
		Uniformity	ΔL	$\theta = 0^\circ$	75	--	--	%
Response Time	Tr	$\theta = 0^\circ$	--	9	--	ms		
	Tf	$\theta = 0^\circ$	--	16	--	ms		
Image Sticking	Tis	2hour	--	--	2	sec		
Viewing Angle	Horizontal		CR 5	-75~75	-85~85	--	°	
	Vertical	θ		-75~75	-85~85	--	°	
	Horizontal		CR 10	-60~60	-70~70	--	°	
	Vertical	θ		-55~55	-65~65	--	°	
Color Coordinates	White	Wx	$\theta = 0^\circ$	0.283	0.313	0.343	--	
		Wy		0.299	0.329	0.359		
	Red	Rx		0.607	0.637	0.667		
		Ry		0.314	0.344	0.374		
	Green	Gx		0.280	0.310	0.340		
		Gy		0.552	0.582	0.612		
	Blue	Bx		0.113	0.143	0.173		
		By		0.070	0.100	0.130		

[Note] These items are measured using CS-1000 (MINOLUTA) OR BM-5A(TOPCON) under the dark room condition(no ambient light) after more than 30 minutes from turning on the lamp unless noted.

Condition: IL=7.0*4(lamp)mA, Inverter Frequency=50kHz.

Definition of these measurement items are as follows:

(1)Definition of Contrast Ratio : CR=ON(White)Luminance/OFF(Black)Luminance

(2)Definition of Luminance and Luminance uniformity

Measure White Luminance on the below center(5) , 5 point(5,10,11,12,13) and 9 point(1~9).

Uniformity : 5 point : $\Delta L = [(L_{MAX} - L_{MIN}) / L_{MIN}] \times 100\%$

9 point : $\Delta L = (L_{MIN} / L_{MAX}) \times 100\%$

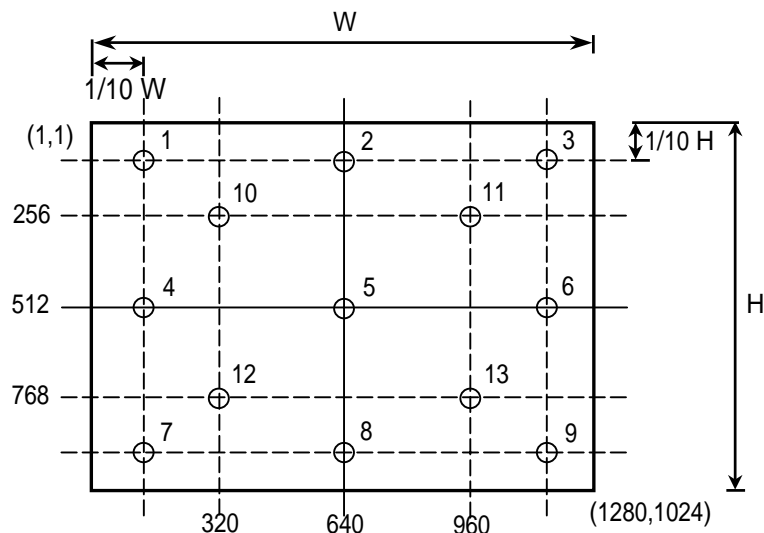

(3) Definition of Viewing Angle(,)

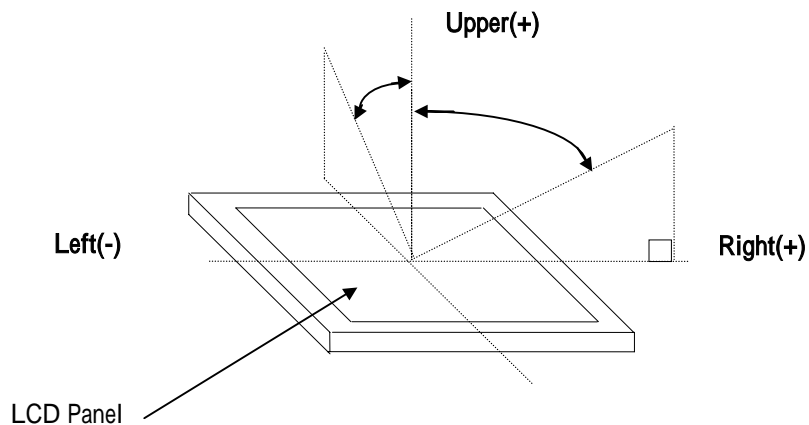

(4) Definition of Response Time

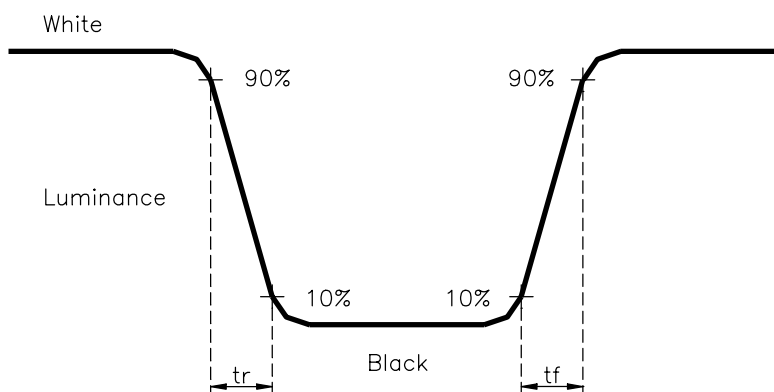

(5) Image sticking:

Continuously display the test pattern shown in the figure below for two-hours. Then display a completely white screen. The previous image shall not persist more than two seconds at 25 .

TEST PATTERN FOR IMAGE STICKING TEST

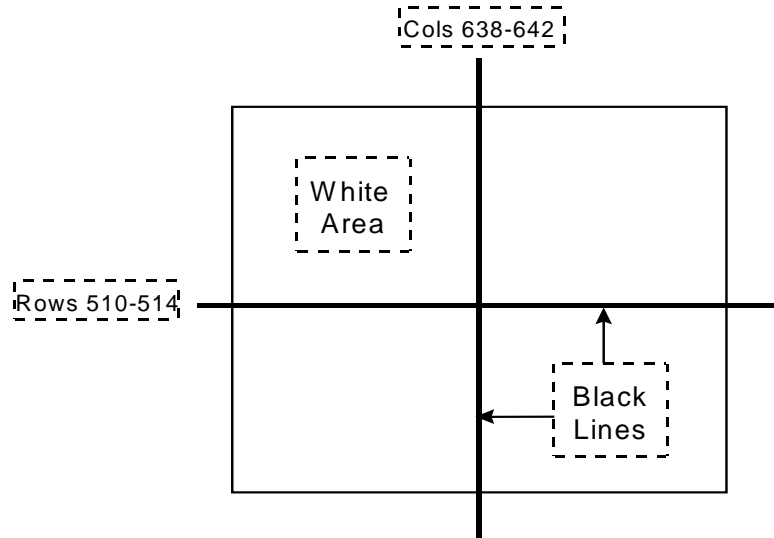

9.RELIABILITY TEST CONDITIONS

(1)Temperature and Humidity

TEST ITEMS	CONDITIONS
HIGH TEMPERATURE HIGH HUMIDITY OPERATION	40 ; 95%RH; 240h (No condensation)
HIGH TEMPERATURE HIGH HUMIDITY STORAGE	60 ; 90%RH;48h (No condensation)
HIGH TEMPERATURE OPERATION	50 ; 240h
LOW TEMPERATURE STORAGE	-20 ; 240h
THERMAL SHOCK	BETWEEN -20 (1hr)AND 60 (1hr); 100 CYCLES
HIGH TEMPERATURE STORAGE	60 ; 240h
LOW TEMPERATURE OPERATION	0 ; 240h

(2)Shock & Vibration

ITEMS	CONDITIONS
SHOCK (NON-OPERATION)	Shock level:1470m/s ² (150G) Waveform: half sinusoidal wave, 2ms Number of shocks: one shock input in each direction of three mutually perpendicular axes for a total of six shock inputs
VIBRATION (NON-OPERATION)	Vibration level: 9.8m/s ² (1.0G) zero to peak Waveform: sinusoidal Frequency range: 5 to 500 Hz Frequency sweep rate: 0.5 octave/min Duration: one sweep from 5 to 500Hz in each of three mutually perpendicular axis(each x,y,z axis: 1 hour, total 3 hours)

(3)Judgment standard

The judgment of the above test should be made as follow:

Pass: Normal display image with no obvious non-uniformity and no line defect.

Partial transformation of the module parts should be ignored.

Fail: No display image, obvious non-uniformity, or line defects.

10. HANDLING PRECAUTIONS FOR TFT-LCD MODULE

Please pay attention to the followings in handling- TFT-LCD products;

1 ASSEMBLY PRECAUTION

- (1) Please use the mounting hole on the module side in installing and do not beading or wrenching LCD in assembling. And please do not drop, bend or twist LCD module in handling.
- (2) Please design display housing in accordance with the following guide lines.
 - (2.1) Housing case must be destined carefully so as not to put stresses on LCD all sides and not to wrench module. The stresses may cause non-uniformity even if there is no non-uniformity statically.
 - (2.2) Keep sufficient clearance between LCD module back surface and housing when the LCD module is mounted. Approximately 1.0 mm of the clearance in the design is recommended taking into account the tolerance of LCD module thickness and mounting structure height on the housing.
 - (2.3) When some parts, such as, FPC cable and ferrite plate, are installed underneath the LCD module, still sufficient clearance is required, such as 0.5mm. This clearance is, especially, to be reconsidered when the additional parts are implemented for EMI countermeasure.
 - (2.4) Design the inverter location and connector position carefully so as not to give stress to lamp cable, or not to interface the LCD module by the lamp cable.
 - (2.5) Keep sufficient clearance between LCD module and the others parts, such as inverter and speaker so as not to interface the LCD module. Approximately 1.0mm of the clearance in the design is recommended.
- (3) Please do not push or scratch LCD panel surface with any-thing hard. And do not soil LCD panel surface by touching with bare hands. (Polarizer film, surface of LCD panel is easy to be flawed.)
- (4) Please do not press any parts on the rear side such as source TCP, gate TCP, control circuit board and FPCs during handling LCD module. If pressing rear part is unavoidable, handle the LCD module with care not to damage them.
- (5) Please wipe out LCD panel surface with absorbent cotton or soft cloth in case of it being soiled.
- (6) Please wipe out drops of adhesives like saliva and water on LCD panel surface immediately. They might damage to cause panel surface variation and color change.
- (7) Please do not take a LCD module to pieces and reconstruct it. Resolving and reconstructing modules may cause them not to work well.
- (8) Please do not touch metal frames with bare hands and soiled gloves. A color change of the metal frames can happen during a long preservation of soiled LCD modules.
- (9) Please pay attention to handling lead wire of backlight so that it is not tugged in connecting with inverter.

2 OPERATING PRECAUTIONS

- (1) Please be sure to turn off the power supply before connecting and disconnecting signal input cable.
 - (2) Please do not change variable resistance settings in LCD module. They are adjusted to the most suitable value. If they are changed, it might happen LCD does not satisfy the characteristics specification.
 - (3) Please consider that LCD backlight takes longer time to become stable of radiation characteristics in low temperature than in room temperature.
 - (4) A condensation might happen on the surface and inside of LCD module in case of sudden change of ambient temperature.
 - (5) Please pay attention to displaying the same pattern for very long time. Image might
-

stick on LCD. If then, time going on can make LCD work well.

- (6) Please obey the same caution descriptions as ones that need to pay attention to ordinary electronic parts.

3 PRECAUTIONS WITH ELECTROSTATICS

- (1) This LCD module use CMOS-IC on circuit board and TFT-LCD panel, and so it is easy to be affected by electrostatics. Please be careful with electrostatics by the way of your body connecting to the ground and so on.
- (2) Please remove protection film very slowly on the surface of LCD module to prevent from electrostatics occurrence.

4 STORAGE PRECAUTIONS

- (1) When you store LCDs for a long time, it is recommended to keep the temperature between 0 ~40 without the exposure of sunlight and to keep the humidity less than 90%RH.
- (2) Please do not leave the LCDs in the environment of high humidity and high temperature such as 60 ~90%RH.
- (3) Please do not leave the LCDs in the environment of low temperature; below -20 .

5 SAFETY PRECAUTIONS

- (1) When you waste LCDs, it is recommended to crush damaged or unnecessary LCDs into pieces and wash them off with solvents such as acetone and ethanol, which should later be burned.
- (2) If any liquid leaks out of a damaged-glass cell and comes in contact with the hands, wash off thoroughly with soap and water.

6 OTHERS

- (1) A strong incident light into LCD panel might cause display characteristics' changing inferior because of polarizer film, color filter, and other materials becoming inferior. Please do not expose LCD module direct sunlight and strong UV rays.
 - (2) Please pay attention to a panel side of LCD module not to contact with other materials in preserving it alone.
 - (3) For the packaging box, please pay attention to the followings:
 - (3.1) Packaging box and inner case for LCD are designed to protect the LCDs from the damage or scratching during transportation. Please do not open except picking LCDs up from the box.
 - (3.2) Please do not pile them up more than 3 boxes. (They are not designed so.) And please do not turn over.
 - (3.3) Please handle packaging box with care not to give them sudden shock and vibrations. And also please do not throw them up.
 - (3.4) Packing box and inner case for LCDs are made of cardboard. So please pay attention not to get them wet. (Such like keeping them in high humidity or wet place can occur getting them wet.)
-