

FEATURES

- **ON-CHIP LOW DISTORTION AMPLIFIER:**
IIP₃ = +2.5 dBm at minimum gain
- **WIDE AGC DYNAMIC RANGE:**
GCR = 50 dB TYP
- **ON-CHIP VIDEO AMPLIFIER:**
V_{OUT} = 1.0 VP-P at single-ended output
- **SUPPLY VOLTAGE:**
V_{CC} = 5 V
- **PACKAGED IN 8 PIN SSOP SUITABLE FOR SURFACE MOUNTING**
- **LOW NOISE FIGURE:**
4.2 dB TYP

DESCRIPTION

Nec's UPC3221GV is a Silicon Monolithic IC designed for use as an AGC Amplifier for digital CATV, cable modem and IP telephony systems. This IC consists of a two stage gain control amplifier and a fixed gain video amplifier. The device provides a differential input and differential output for noise performance, which eliminates shielding requirements.

The package is 8-pin SSOP (Shrink Small Outline Package) suitable for surface mount.

This IC is manufactured using NEC's 10 GHz f_T NESAT™ II AL silicon bipolar process. This process uses silicon nitride passivation film. This material can protect chip surface from external pollution and prevent corrosion/migration. Thus, this IC has excellent performance, uniformity and reliability.

NEC's stringent quality assurance and test procedures ensure the highest reliability and performance.

INTERNAL BLOCK DIAGRAM AND PIN CONFIGURATION

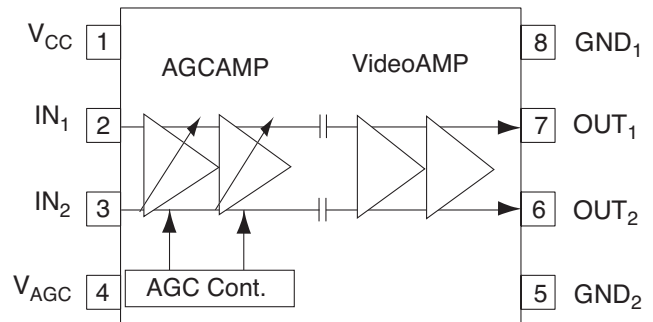

PACKAGE OUTLINE S08

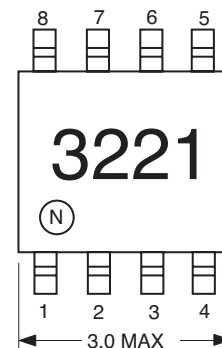

All dimensions are typical unless specified otherwise.

APPLICATIONS

- Digital CATV
- Cable modem receivers
- IP Telephony receivers

ELECTRICAL CHARACTERISTICS

(T_A = 25°C, V_{CC} = 5 V, Z_s = 1KΩ, Z_L = 1KΩ, f_{IN} = 45 MHz, single-ended output), unless otherwise noted

PART NUMBER PACKAGE OUTLINE			UPC3221GV S08		
SYMBOLS	PARAMETERS AND CONDITIONS	UNITS	MIN	TYP	MAX
DC Characteristics					
I _{CC}	Circuit Current ¹ (no input signal)	mA	26	33	41
I _{AGC (H)}	AGC Pin Current ¹ , No input Signal, V _{AGC} = 3.5 V	V	-	16	50
V _{AGC (H)}	AGC Voltage High Level ¹ , at Maximum gain	V	3.0	-	3.5
V _{AGC (L)}	AGC Voltage Low Level ¹ , at Minimum gain	V	0	-	0.5
RF Characteristics					
G _{MAX}	Maximum Gain ¹ , V _{AGC} = 3.0 V, P _{in} = -60 dBm	dB	57	60	63
G _{MID1}	Middle Gain ¹ , V _{AGC} = 2.2 V, P _{in} = -60 dBm	dB	47.5	50.5	53.5

UPC3221GV

ELECTRICAL CHARACTERISTICS, cont.

($T_A = 25^\circ\text{C}$, $V_{CC} = 5\text{ V}$, $f_{IN} = 45\text{ MHz}$, $Z_S = 50\Omega$, $Z_L = 250\Omega$, single-ended output), unless otherwise noted

PART NUMBER PACKAGE OUTLINE			UPC3221GV S08		
SYMBOLS	PARAMETERS AND CONDITIONS	UNITS	MIN	TYP	MAX
RF Characteristics					
G_{MID2}	Middle Gain 2 ¹ , $V_{AGC} = 1.2\text{ V}$, $P_{IN} = -30\text{ dBm}$	dB	18	21	24
G_{MIN}	Minimum Gain ¹ , $V_{AGC} = 0.5\text{ V}$, $P_{IN} = -30\text{ dBm}$	dB	6	10	14
G_{CRin}	Gain Control Range Input ¹ , $V_{AGC} = 0.5\text{ to }3.0\text{ V}$	dB	43	50	–
G_{CRout}	Gain Control Range Output ¹ , $V_{out} = 1.0\text{ V}_{p-p}$	dB	36	40	–
G_{slope}	Gain Control Slope ¹ , Gain (at $V_{AGC} = 2.2\text{ V}$) - Gain (at $V_{AGC} = 1.2\text{ V}$)	dB	26.5	29.5	32.5
V_{oclip}	Maximum Output Voltage ¹ , $V_{AGC} = 3.0\text{ V}$ at maximum gain	V_{p-p}	2.0	2.8	–
NF	Noise Figure ³ , $V_{AGC} = 3.0\text{ V}$ at maximum gain	dB	–	4.2	5.7
$IM_3\ 1$	Third Order Intermodulation Distortion ¹ , $f_{IN1} = 44\text{ MHz}$, $f_{IN2} = 45\text{ MHz}$, $P_{IN} = -30\text{ dBm/tone}$, $V_{out} = 0.7\text{ V}_{p-p}/\text{tone}$ at single ended output, $Z_L = 250\ \Omega$	dBc	43	47	–
$IM_3\ 2$	Third Order Intermodulation Distortion ¹ 2, $f_{IN1} = 44\text{ MHz}$, $f_{IN2} = 45\text{ MHz}$, $V_{AGC} = 3.0\text{ V}$ at maximum gain, $V_{out} = 0.7\text{ V}_{p-p}/\text{tone}$ at single ended output, $Z_L = 250\ \Omega$	dBc	50	56	–
ΔG	Gain ^{1,2} , $V_{AGC} = 3.0\text{ V}$, $P_{in} = -60\text{ dBm}$, $Z_L = 250\ \Omega$, $\Delta G = G$ at P_{out1} -G at P_{out2}	dB	-0.5	0	+0.5

STANDARD CHARACTERISTICS ($T_A = 25^\circ\text{C}$, $V_{CC} = 5\text{ V}$, $Z_S = 50\Omega$), unless otherwise noted

PART NUMBER PACKAGE OUTLINE		UPC3221GV S08	
SYMBOLS	PARAMETERS	UNITS	REFERENCE VALUE
NF2	GAIN Recuction ³ = -10 dB	dB	6.0
NF3	GAIN Recuction ³ = -20 dB	dB	9.5
V_{out}	$P_{in}^1 = -56\text{ to }-16\text{ dBm}$	V_{p-p}	1.0
Z_{in}	Input Impedance ⁴ = 0.5 V , $f = 45\text{ MHz}$	Ω	0.9k - j1.4k
Z_{out}	Output Impedance ⁴ = 0.5 V , $f = 45\text{ MHz}$	Ω	9.0+j1.9
IIP_3	3rd Order Input Intercept Point ¹ = $V_{AGC} = 0.5\text{ V}$ at minmum gain, $f_1 = 44\text{ MHz}$, $f_2 = 45\text{ MHz}$, $Z_L = 250\ \Omega$ at single ended output	dBm	+2.5

Note:

- By measurement Circuit 1
- By measurement Circuit 2
- By measurement Circuit 3
- By measurement Circuit 4

ABSOLUTE MAXIMUM RATINGS^{1,2}

($T_A = 25^\circ\text{C}$, $V_{CC} = 5\text{ V}$, $Z_S = 50\ \Omega$, unless otherwise specified)

SYMBOLS	PARAMETERS	UNITS	RATINGS
V_{CC}	Voltage Current	V	6.0
$V_{AGC}\ (H)$	AGC Voltage	V	0 to V_{CC}
P_D	Power Dissipation ²	mW	250
T_A	Operating Ambient Temp. ¹	$^\circ\text{C}$	-40 to +85
T_{STG}	Operating Ambient Temp. ¹	$^\circ\text{C}$	-55 to +150

Notes:

- Operation in excess of any one of these parameters may result in permanent damage.
- Mounted on a $50 \times 50 \times 1.6\text{ mm}$ epoxy glass PWB, with copper patterning on both sides, $T_A = 85^\circ\text{C}$

RECOMMENDED OPERATING CONDITIONS

SYMBOL	PARAMETER	UNITS	MIN	TYP	MAX
V_{CC}	Supply Voltage	V	4.5	5.0	5.5
T_A	Operating Ambient Temp. ¹	$^\circ\text{C}$	-40	+25	+85
V_{AGC}	Gain Control Voltage Range	V	0	–	3.5
fbw	Video Input Signal Range	dBmV	10	45	100

Note:

- $V_{CC} = 4.5\text{ to }5.5\text{ V}$

PIN EXPLANATIONS

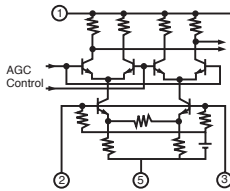
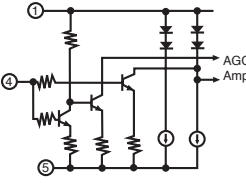
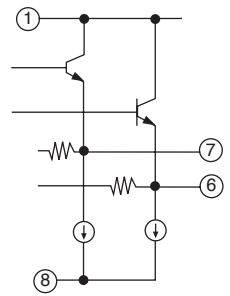
Pin No.	Name	Applied Voltage (v)	Pin Voltage (v) ¹	Description	Internal Equivalent Circuit
1	Vcc	4.5 to 5.5		Power supply pin. This pin should be externally equipped with bypass capacitor to minimize ground impedance.	
2	INPUT1		1.29	Signal input pins of AGC amplifier.	
3	INPUT2		1.29		
4	VAGC	0 to Vcc		Gain control pin. This pin's bias govern the AGC output level. Minimum Gain at VAGC = 0.5 V Maximum Gain at VAGC = 3 to 3.5 V Recommended to use by dividing AGC voltage with external resistor (ex. 1kΩ)	
5	GND 2	0		Ground pin. This pin should be connected to system ground with minimum inductance. Ground pattern on the board should be formed as wide as possible.	
6	OUTPUT2		2.28	Signal output pins of video amplifier	
7	OUTPUT1		2.28		
8	GND 1	0		Ground pin. This pin should be connected to system ground with minimum inductance. Ground pattern on the board should be formed as wide as possible. All ground pins must be connected together with wide ground pattern to decrease impedance difference.	

Note:

1. PIN is measured at Vcc = 5 V

MEASUREMENT CIRCUIT 1

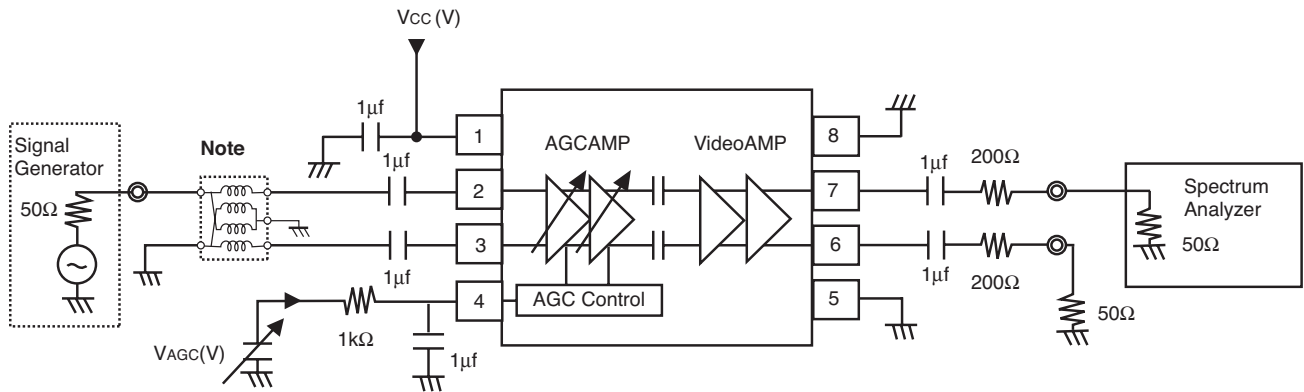

Note: Balun Transformer : TOKO 617DB-1010 B4F (Double balanced type)

MEASUREMENT CIRCUIT 2

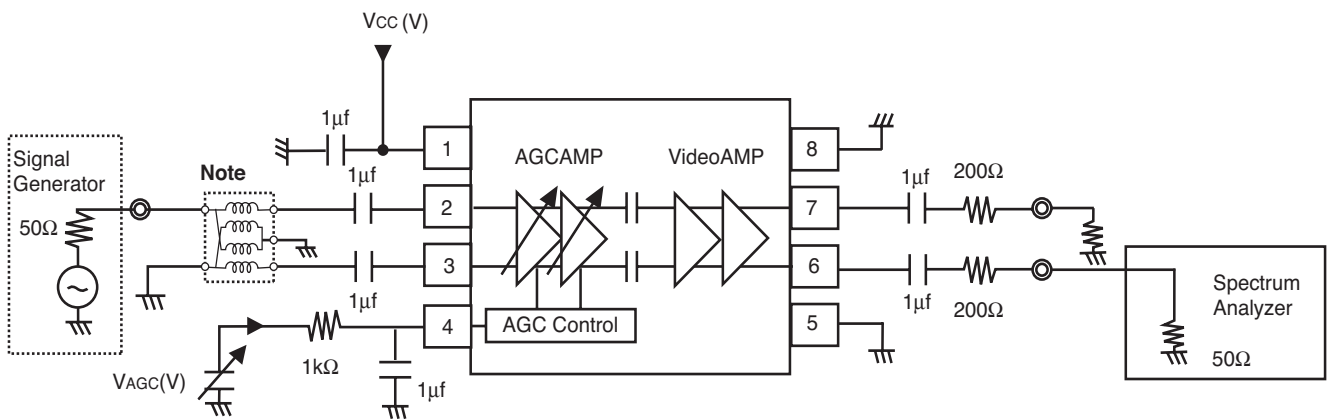

Note: Balun Transformer : TOKO 617DB-1010 B4F (Double balanced type)

MEASUREMENT CIRCUIT 3

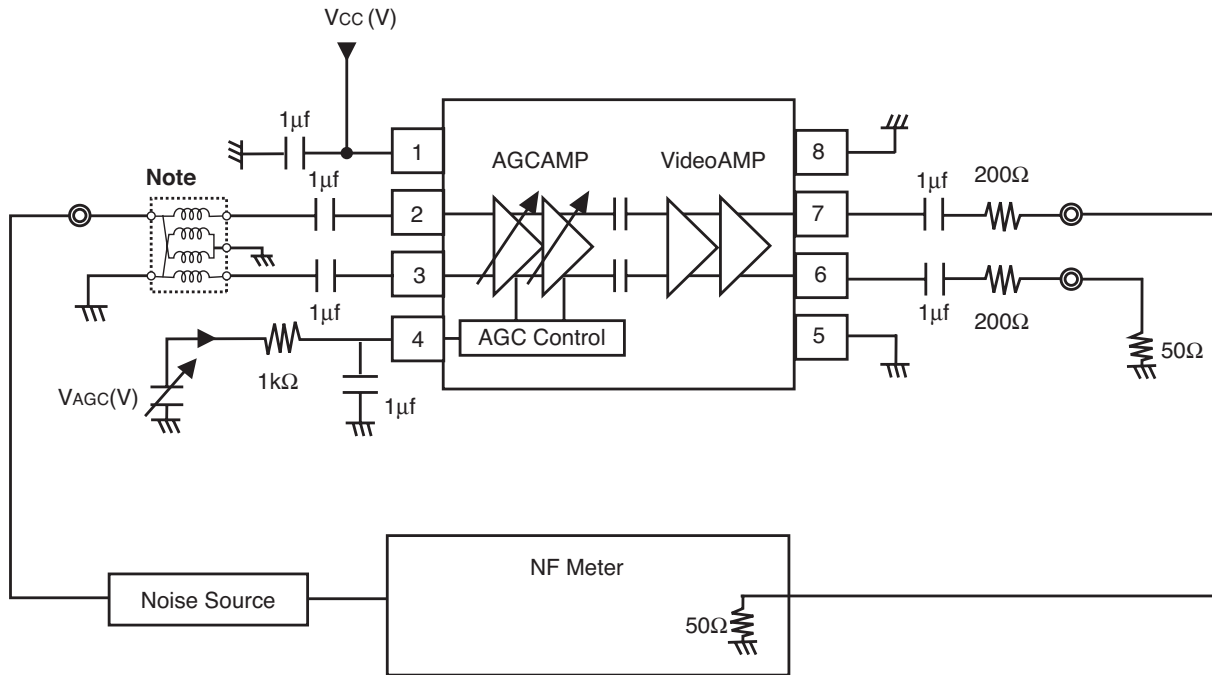

Note: Balun Transformer : TOKO 617DB-1010 B4F (Double balanced type)

MEASUREMENT CIRCUIT 4

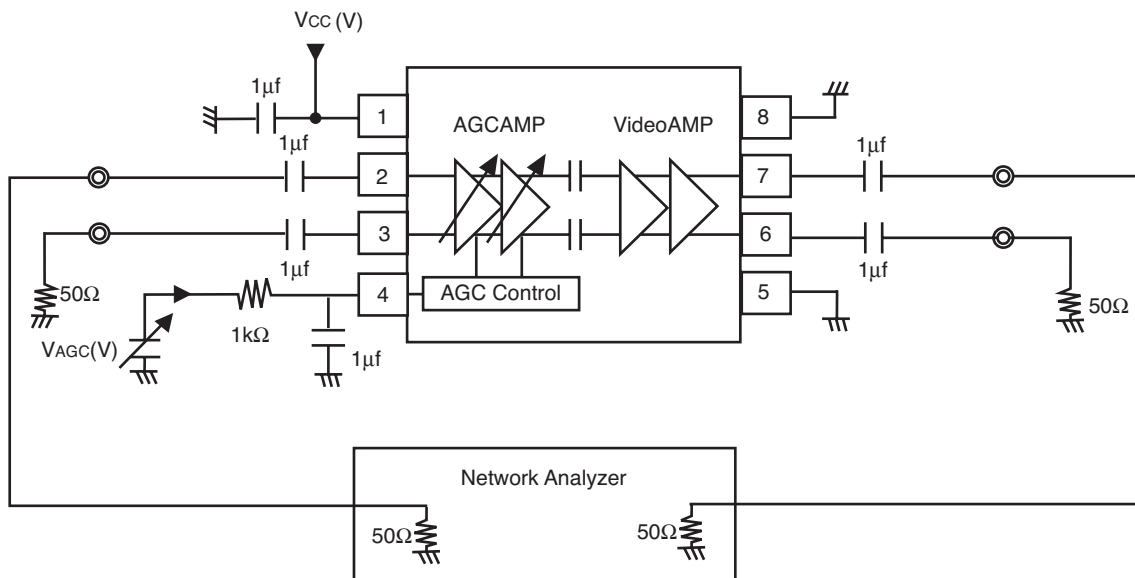

OUTLINE DIMENSIONS (Units in mm)

PACKAGE OUTLINE S08

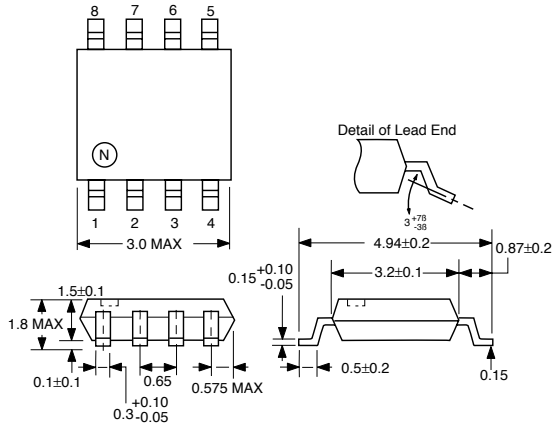

All dimensions are typical unless specified otherwise.

ORDERING INFORMATION

PART NUMBER	QUANTITY
UPC3221GV-E1	1 kp/reel

Note:
 Embossed tape 8 mm wide. Pin 1 indicates pull-out direction of tape.

Life Support Applications

These NEC products are not intended for use in life support devices, appliances, or systems where the malfunction of these products can reasonably be expected to result in personal injury. The customers of CEL using or selling these products for use in such applications do so at their own risk and agree to fully indemnify CEL for all damages resulting from such improper use or sale.