



ADVANCED INFORMATION

2V Control Triple-Band GSM/DCS/PCS SP5T Switch
0.5 – 2.0 GHz

SW-444
Rev 1.4

Features

- GSM Power Handling with +2.0V Control Voltage
- Low Power Consumption. Less than 1µA in Rx mode
- Integrated Decoder
- Leadless 4 x 4 mm FQFP-N, 20 Pin Package
- Low Insertion Loss of 0.6 dB in GSM Transmit Mode

Description

The M/A-COM SW-444 is a GaAs monolithic switch in a low cost, FQFP-N, surface mount plastic package. The SW-444 is ideally suited for applications where very low power consumption, high power handling, and low cost are required. The SW-444 includes an integrated decoder. This switch is designed for Transmit and Receive switching for Triple-Band GSM/DCS/PCS Mobile Phones. The switch offers GSM power handling as low as +2.0 V control voltage. The supply voltage VDD should be connected to the highest available voltage and may be unregulated.

The SW-444 is fabricated using a new 0.5-micron gate length GaAs pHEMT process. The process features full chip passivation for increased performance and reliability.

Functional Schematic

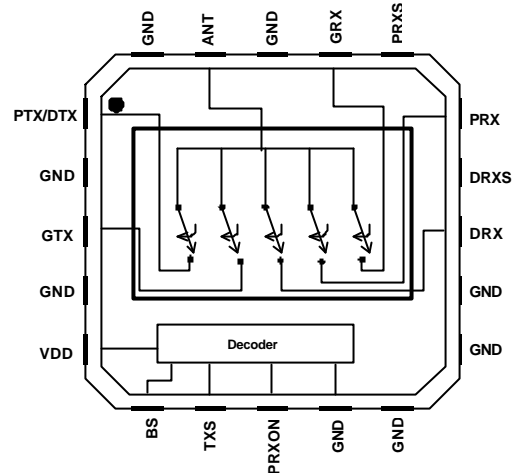

Ordering Information

Part Number	Description
SW-444TR	SW-444 on 1000 Piece Tape and Reel
SW-444TR-3000	SW-444 on 3000 Piece Tape and Reel
SW-444SMB	SW-444 Sample Test Board

The Advanced Information Data Sheet Contains Typical Electrical Specifications Which May Change Prior to Final Introduction.

M/A-COM, Inc.

North America: Tel. (800) 366-2266
Fax (800) 618-8883

♦ Asia/Pacific: Tel. +81 3 3263-8761
Fax +81 3 3263-8769

♦ Europe: Tel. +44 (1344) 869-595
Fax +44 (1344) 300-020

ELECTRICAL CHARACTERISTICS: Test Conditions: VDD = 2.5V, Vctrl = 2.0V, TA = +25°C

Mode	Specifications	Freq. (MHz)	Units	Min.	Typ.	Max.
ANT -> GSM RX	Insertion Loss	925 - 960	dB	0.74	0.8	0.9
	Isolation GSM Tx to ANT	880 - 915	dB	25	27	30
	Isolation GSM Tx to GSM Rx	880 - 915	dB	26	28	30
	Isolation GSM Tx to PCS Rx	880 - 915	dB	32	>35	52
	Isolation GSM Tx to DCS Rx	880 - 915	dB	32	>35	64
	Isolation PCS/DCS Tx to ANT	1710 - 1785	dB	22	24	26
	Isolation PCS/DCS Tx to GSM Rx	1710 - 1785	dB	23	25	27
	Isolation PCS/DCS Tx to PCS Rx	1710 - 1785	dB	32	>35	43
	Isolation PCS/DCS Tx to DCS Rx	1710 - 1785	dB	32	>35	54
ANT -> PCS RX	Insertion Loss	1930 - 1990	dB	0.94	1.0	1.1
	Isolation GSM Tx to ANT	880 - 915	dB	25	27	29
	Isolation GSM Tx to GSM Rx	880 - 915	dB	32	>35	55
	Isolation GSM Tx to PCS Rx	880 - 915	dB	26	28	30
	Isolation GSM Tx to DCS Rx	880 - 915	dB	32	>35	52
	Isolation PCS/DCS Tx to ANT	1710 - 1785	dB	22	24	26
	Isolation PCS/DCS Tx to GSM Rx	1710 - 1785	dB	32	>35	42
	Isolation PCS/DCS Tx to PCS Rx	1710 - 1785	dB	23	25	27
	Isolation PCS/DCS Tx to DCS Rx	1710 - 1785	dB	32	>35	42
	ANT -> DCS RX	Insertion Loss	1805 - 1880	dB	0.94	1.0
	Isolation GSM Tx to ANT	880 - 915	dB	25	27	29
	Isolation GSM Tx to GSM Rx	880 - 915	dB	32	>35	56
	Isolation GSM Tx to PCS Rx	880 - 915	dB	32	>35	60
	Isolation GSM Tx to DCS Rx	880 - 915	dB	26	28	30
	Isolation PCS/DCS Tx to ANT	1710 - 1785	dB	22	24	26
	Isolation PCS/DCS Tx to GSM Rx	1710 - 1785	dB	32	>35	44
	Isolation PCS/DCS Tx to PCS Rx	1710 - 1785	dB	32	>35	51
	Isolation PCS/DCS Tx to DCS Rx	1710 - 1785	dB	23	25	27
	ANT -> GSM TX	Insertion Loss	880 - 915	dB	0.54	0.6
	Isolation GSM Tx to GSM Rx	880 - 915	dB	29	31	33
	Isolation GSM Tx to PCS Rx	880 - 915	dB	31	33	35
	Isolation GSM Tx to DCS Rx	880 - 915	dB	32	34	36
	Isolation PCS/DCS Tx to ANT	1710 - 1785	dB	22	24	26
	Isolation PCS/DCS Tx to GSM Rx	1710 - 1785	dB	32	>35	44
	Isolation PCS/DCS Tx to PCS Rx	1710 - 1785	dB	32	>35	59
	Isolation PCS/DCS Tx to DCS Rx	1710 - 1785	dB	32	>35	59
ANT -> PCS/DCS TX	Insertion Loss	1710 - 1785	dB	0.84	0.9	1.0
	Isolation GSM Tx to ANT	880 - 915	dB	25	27	29
	Isolation GSM Tx to GSM Rx	880 - 915	dB	32	>35	55
	Isolation GSM Tx to PCS Rx	880 - 915	dB	32	>35	60
	Isolation GSM Tx to DCS Rx	880 - 915	dB	32	>35	64
	Isolation PCS/DCS Tx to GSM Rx	1710 - 1785	dB	23	25	27
	Isolation PCS/DCS Tx to PCS Rx	1710 - 1785	dB	32	34	36
	Isolation PCS/DCS Tx to DCS Rx	1710 - 1785	dB	31	33	35
ANT/PRX/DRX/GRX -> GND (IDLE MODE)	Isolation GSM Tx to ANT , FREQ = 900 MHz	925 - 960	dB	34	34	34
	Isolation PCS/DCS Tx to ANT , FREQ = 1810 MHz	925 - 960	dB	34	34	34
2nd Harmonics	Freq = 900 MHz, Input Power = +34 dBm		dBc	-84	-79	-70
	Freq = 1810 MHz, Input Power = +32 dBm		dBc	-84	-79	-65
3rd Harmonics	Freq = 900 MHz, Input Power = +34 dBm		dBc	-73	-69	-65
	Freq = 1810 MHz, Input Power = +32 dBm		dBc	-73	-69	-65
Supply Voltage			Volts	2.0	2.5	4.0
High Control Voltages			Volts	2.0	2.5	4.0
Low Control Voltages			Volts	-0.2	0	0.2

- DC blocking capacitors are required on all RF and shunt ports.
- All impedances are 50 ohms.

The Advanced Information Data Sheet Contains Typical Electrical Specifications Which May Change Prior to Final Introduction.

M/A-COM, Inc.

2

North America: Tel. (800) 366-2266
Fax (800) 618-8883

♦ Asia/Pacific: Tel. +81 3 3263-8761
Fax +81 3 3263-8769

♦ Europe: Tel. +44 (1344) 869-595
Fax +44 (1344) 300-020

Pin Configuration

Pin No.	Pin Name	Description
1	PTX/DTX	PCS/DCS Tx Port
2	GND	RF Ground
3	GTX	GSM Tx Port
4	GND	RF Ground
5	VDD	Decoder VDD
6	BS	Control 1
7	TXS	Control 2
8	PRXON	Control 3
9	GND	RF Ground
10	GND	RF Ground
11	GND	RF Ground
12	GND	RF Ground
13	DRX	DCS Rx Port
14	DRXS	DCS Rx Shunt
15	PRX	PCS Rx Port
16	PRXS	PCS Rx Shunt
17	GRX	GSM Rx Port
18	GND	RF Ground
19	ANT	ANT Port
20	GND	RF Ground
21	GND	Paddle

Block Diagram

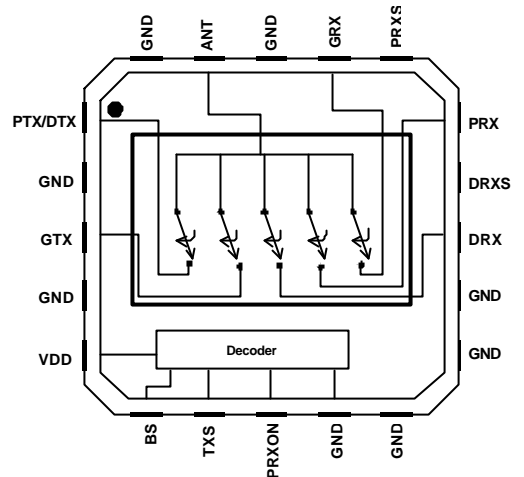

Truth Table

BS	TXS	PRXON	MODE
0	0	0	GSM RX - ANT
0	1	0	GSM TX - ANT
1	1	0	PCS TX/DCS TX - ANT
1	0	0	DCS RX - ANT
1	0	1	PCS RX - ANT

Logic Level	Voltage Level
VLo "0" =	0V
VHi "1" =	2.5V

The Advanced Information Data Sheet Contains Typical Electrical Specifications Which May Change Prior to Final Introduction.

M/A-COM, Inc.

North America: Tel. (800) 366-2266
Fax (800) 618-8883

♦ Asia/Pacific: Tel. +81 3 3263-8761
Fax +81 3 3263-8769

♦ Europe: Tel. +44 (1344) 869-595
Fax +44 (1344) 300-020

Sample Board Schematic

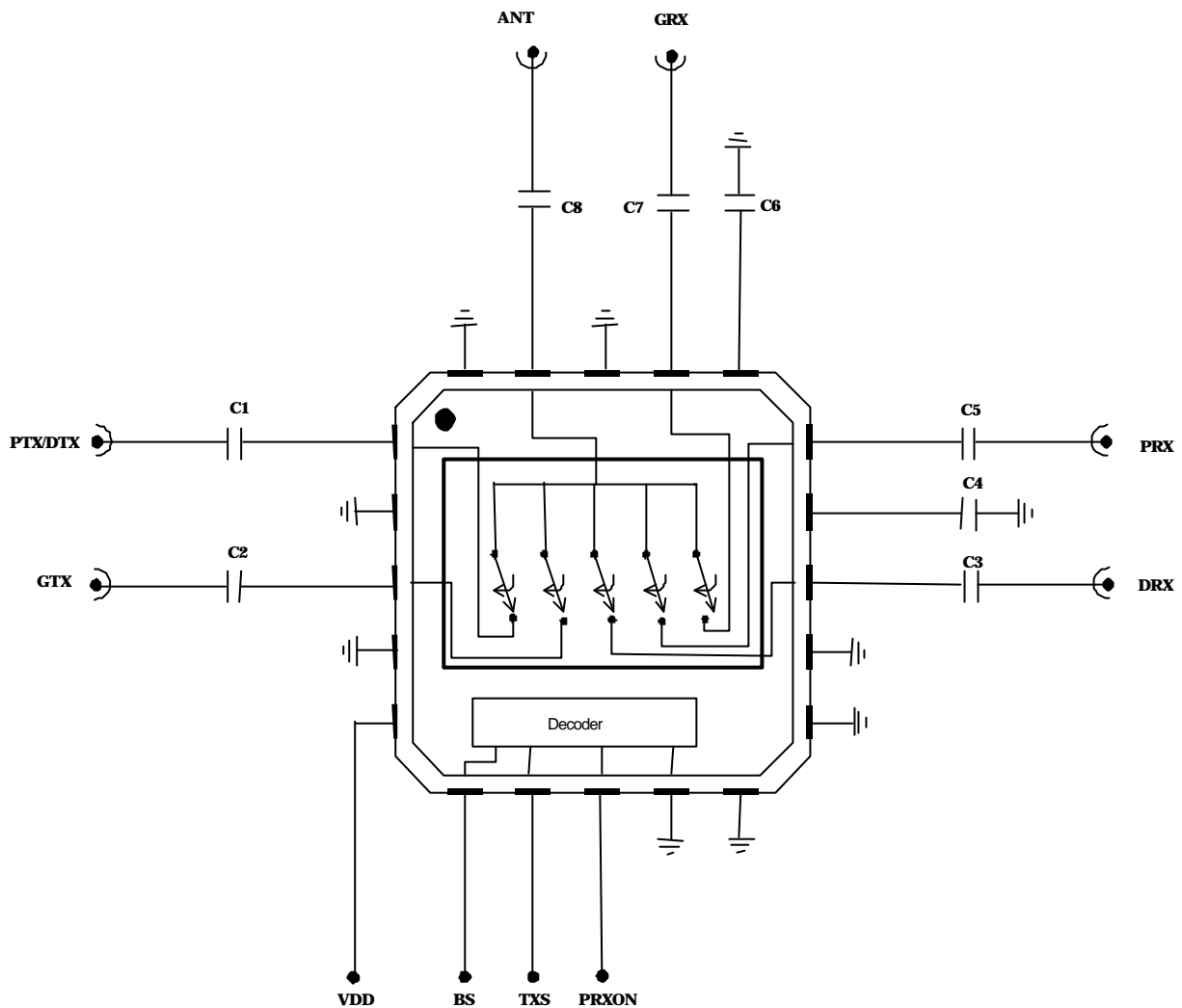

External Circuitry Parts List (Note: Values of external elements not final)

Ref. Designation	Value	Purpose
C1	22pF	DC Block
C2	22pF	DC Block
C3	22pF	DC Block
C4	4.7pF	RF Shunt
C5	22pF	DC Block
C6	4.7pF	RF Shunt
C7	22pF	DC Block
C8	22pF	DC Block

The Advanced Information Data Sheet Contains Typical Electrical Specifications Which May Change Prior to Final Introduction.

M/A-COM, Inc.

North America: Tel. (800) 366-2266
Fax (800) 618-8883

♦ Asia/Pacific: Tel. +81 3 3263-8761
Fax +81 3 3263-8769

♦ Europe: Tel. +44 (1344) 869-595
Fax +44 (1344) 300-020

4 mm FQFP-N, 20-Lead

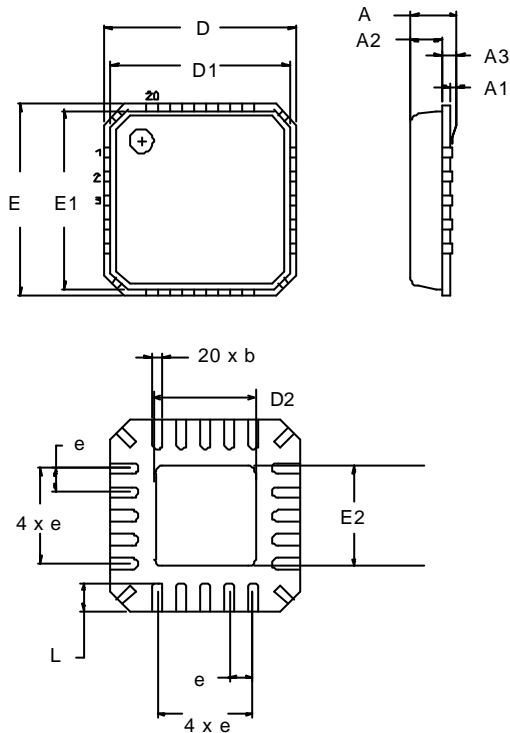

Dimension	Measurement (mm)		
	Min.	Nom.	Max.
A	0.80	0.90	1.00
A1	0	0.02	0.05
A2	0	0.65	1.00
A3		0.25 ref.	
b	0.18	0.23	0.30
D		4.00 basic	
D1		3.75 basic	
D2	0.75	1.70	2.25
e		0.50 basic	
E		4.00 basic	
E1		3.75 basic	
E2	0.75	1.70	2.25
L	0.35	0.55	0.75

Note: See JEDEC MO-220A VGGD-1 for additional dimensional and tolerance information

The Advanced Information Data Sheet Contains Typical Electrical Specifications Which May Change Prior to Final Introduction.

M/A-COM, Inc.

North America: Tel. (800) 366-2266
Fax (800) 618-8883

♦ Asia/Pacific: Tel. +81 3 3263-8761
Fax +81 3 3263-8769

♦ Europe: Tel. +44 (1344) 869-595
Fax +44 (1344) 300-020