

Series Number
 DN4835
 DN6149
 DN8140
 DN8155
 DN1047
 DN1058



3003 9th Avenue SW
 PO Box 50
 Watertown, SD 57201
 Toll free: 888-978-2638
 Ph: 605-886-3326
 Fax: 605-886-8995



SMD Unshielded Inductor Series; Part Numbering Sequence: (Series Number) - (Suffix Code)(Tolerance), example DQ1260-220M
 Bulk Packaging add (-B) to end of Part Numbering Sequence. example DQ1260-22M-B

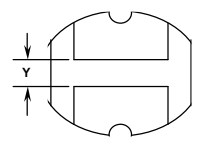
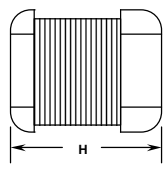
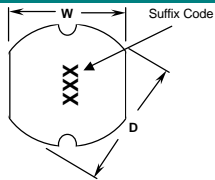
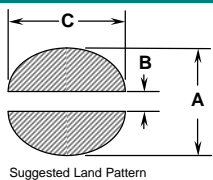

Series Number	Units	Maximum Dimensions				Reference Dimensions			
		D	W	H	Y	A	B	C	
DN4835	inches	0.189"	0.169"	0.138"	0.047"	0.217"	0.047"	0.169"	
	[mm]	[4.80]	[4.30]	[3.50]	[1.20]	[5.50]	[1.20]	[4.30]	
DN6149	inches	0.240"	0.217"	0.193"	0.051"	0.268"	0.051"	0.217"	
	[mm]	[6.10]	[5.50]	[4.90]	[1.30]	[6.80]	[1.30]	[5.50]	
DN8140	inches	0.319"	0.287"	0.157"	0.083"	0.346"	0.083"	0.287"	
	[mm]	[8.10]	[7.30]	[4.00]	[2.10]	[8.80]	[2.10]	[7.30]	
DN8155	inches	0.319"	0.287"	0.217"	0.083"	0.346"	0.083"	0.287"	
	[mm]	[8.10]	[7.30]	[5.50]	[2.10]	[8.80]	[2.10]	[7.30]	
DN1047	inches	0.406"	0.366"	0.185"	0.114"	0.433"	0.114"	0.366"	
	[mm]	[10.30]	[9.30]	[4.70]	[2.90]	[11.00]	[2.90]	[9.30]	
DN1058	inches	0.409"	0.370"	0.228"	0.114"	0.433"	0.114"	0.370"	
	[mm]	[10.40]	[9.40]	[5.80]	[2.90]	[11.00]	[2.90]	[9.40]	

- Features:**
- High energy storage and low resistance
 - Reliable surface mounting, flat top for pick and place.
 - Smaller real estate than other common inductors.
 - Robust temperature deflection to prevent damage during solder reflow.
 - Tape and Reel mechanical specifications available upon request.
 - Operating Temperature -40°C to +85°C.
 - Highly resistive core for EMI suppression applications.

L ¹ μH	Suffix Codes	DN4835			DN6149			DN8140			DN8155			DN1047			DN1058		
		DCR ² W	I _{SAT} ³ A	Tolerance Suffix ⁴	DCR ² W	I _{MAX} ³ A	Tolerance Suffix ⁴	DCR ² W	I _{MAX} ³ A	Tolerance Suffix ⁴	DCR ² W	I _{MAX} ³ A	Tolerance Suffix ⁴	DCR ² W	I _{MAX} ³ A	Tolerance Suffix ⁴	DCR ² W	I _{MAX} ³ A	Tolerance Suffix ⁴
1.0	1R0	0.033	3.80	M															
1.4	1R4	0.038	3.30	M															
1.8	1R8	0.042	2.91	M															
2.2	2R2	0.047	2.60	M															
2.7	2R7	0.052	2.43	M															
3.3	3R3	0.058	2.15	M															
3.9	3R9	0.076	1.98	M															
4.7	4R7	0.094	1.70	M															
5.6	5R6	0.101	1.60	M															
6.8	6R8	0.117	1.41	M	0.08	1.6	M												
8.2	8R2	0.132	1.26	M															
10	100	0.182	1.15	M	0.10	1.44	M	0.08	1.44	M	0.07	2.30	K	0.05	2.38	M	0.06	2.60	M
12	120	0.210	1.05	M	0.12	1.40	M	0.09	1.39	M	0.08	2.00	K	0.06	2.13	M	0.07	2.45	M
15	150	0.235	0.92	M	0.14	1.30	M	0.10	1.24	M	0.09	1.80	K	0.07	1.87	M	0.08	2.27	M
18	180	0.338	0.84	M	0.15	1.23	M	0.11	1.12	M	0.10	1.60	K	0.08	1.73	M	0.09	2.15	M
22	220	0.378	0.76	M	0.18	1.11	M	0.13	1.07	M	0.11	1.50	K	0.09	1.60	M	0.10	1.95	M
27	270	0.522	0.71	M	0.20	0.97	M	0.15	0.94	M	0.12	1.30	K	0.10	1.44	M	0.11	1.76	M
33	330	0.540	0.64	K	0.23	0.88	L	0.17	0.85	M	0.13	1.20	K	0.12	1.26	M	0.12	1.50	M
39	390	0.587	0.59	K	0.32	0.80	L	0.22	0.74	M	0.16	1.10	K	0.15	1.20	M	0.14	1.37	M
47	470	0.844	0.54	K	0.37	0.72	L	0.25	0.68	M	0.18	1.10	K	0.17	1.10	M	0.17	1.28	K
56	560	0.937	0.50	K	0.42	0.68	K	0.28	0.64	K	0.24	0.94	K	0.20	1.01	K	0.19	1.17	K
68	680	1.117	0.46	K	0.46	0.61	K	0.33	0.59	K	0.28	0.85	K	0.22	0.91	K	0.22	1.11	K
82	820				0.60	0.58	K	0.41	0.54	K	0.37	0.78	K	0.25	0.85	K	0.25	1.00	K
100	101				0.70	0.52	K	0.48	0.51	K	0.43	0.72	K	0.34	0.74	K	0.35	0.97	K
120	121				0.93	0.48	K	0.54	0.49	K	0.47	0.66	K	0.40	0.69	K	0.40	0.89	K
150	151				1.10	0.40	K	0.75	0.40	K	0.64	0.58	K	0.54	0.61	K	0.47	0.78	K
180	181				1.38	0.38	K	1.02	0.36	K	0.71	0.51	K	0.62	0.56	K	0.63	0.72	K
220	221				1.57	0.35	K	1.20	0.31	K	0.96	0.49	K	0.72	0.53	K	0.73	0.66	K
270	271							1.31	0.29	K	1.11	0.42	K	0.95	0.45	K	0.97	0.57	K
330	331							1.50	0.28	K	1.26	0.40	K	1.10	0.42	K	1.15	0.52	K
390	391										1.77	0.36	K	1.24	0.38	K	1.30	0.48	K
470	471										1.96	0.34	K	1.53	0.35	K	1.48	0.42	K
560	561													1.90	0.32	K	1.90	0.33	K
680	681																2.25	0.28	K
820	821																2.55	0.24	K
1000	102	11.5	0.11	K															

1) Test conditions are 1Vrms and 1.0-8.2μH(7.96MHz), 10-82μH (2.52MHz) 100-1000μH (1kHz).
 2) DCRs (DC resistances) are maximums @20°C.
 3) DC (Direct Current) current applied to produce a typical 10% drop in inductance or a temperature increase of 40°C whichever is lower. Maximum current is DC + AC.
 4) Suffix of J=5%, K=±10%, L=±15%, M=20%, N=±40%-30%

Specifications subject to change without notice.

Call Toll Free: 888-978-2638 Website: www.coev.net

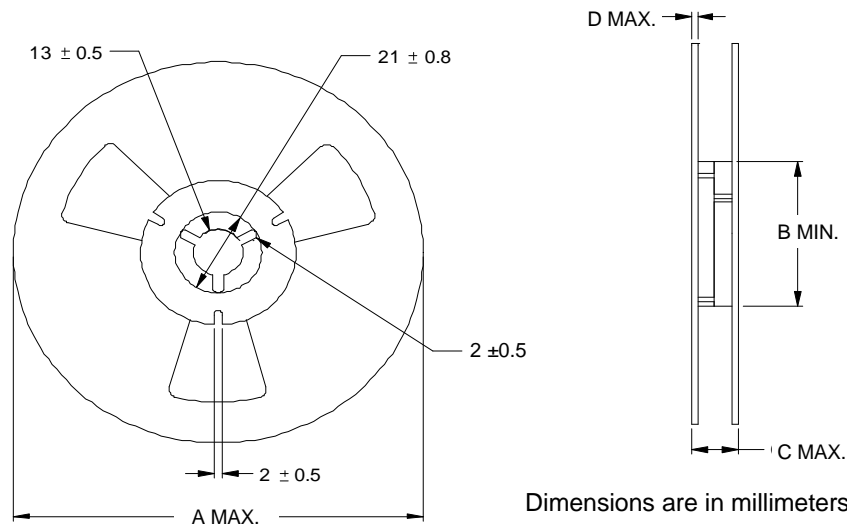

Dimensions are in millimeters unless specified.

Series Number	Units	Reel dimensions				Reel Qty	Packaging Specification
		A	B	C	D		
DN4835	in.	12.99"	4.02"	0.87"	0.106"	2000	90-0049
	[mm]	[330]	[102.0]	[22.2]	[2.70]		
DN6149	in.	12.99"	4.02"	0.87"	0.106"	1000	90-0050
	[mm]	[330]	[102.0]	[22.2]	[2.70]		
DN8140	in.	12.99"	4.02"	0.87"	0.106"	1000	90-0047
	[mm]	[330]	[102.0]	[22.2]	[2.70]		
DN8155	in.	12.99"	4.02"	0.87"	0.106"	1000	90-0048
	[mm]	[330]	[102.0]	[22.2]	[2.70]		
DN1047	in.	12.99"	4.02"	1.19"	0.106"	1000	90-0051
	[mm]	[330]	[102.0]	[30.2]	[2.70]		
DN1058	in.	12.99"	4.02"	1.19"	0.106"	800	90-0052
	[mm]	[330]	[102.0]	[30.2]	[2.70]		

PACKAGING NOTE: Only pressure sensitive cover tape is to be used.

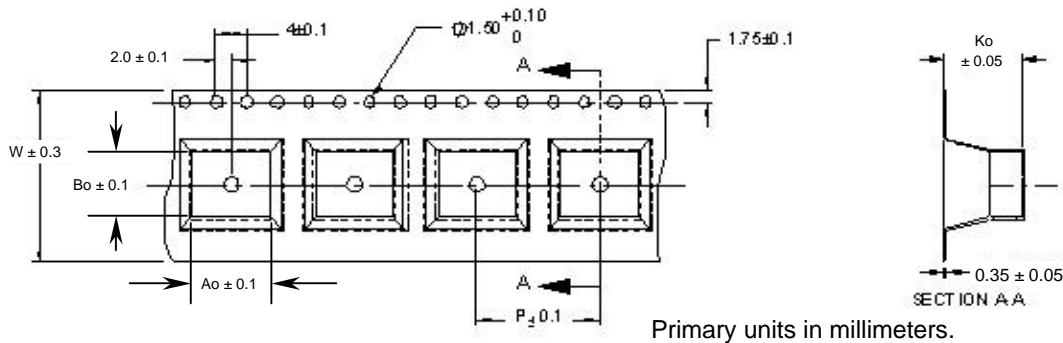

Primary units in millimeters.

Series	Ao	Bo	W	P	Ko
DN4835	4.20	4.60	16.0	8.0	4.00
DN6149	5.40	6.10	16.0	12.0	5.30
DN8140	6.60	7.00	16.0	12.0	4.10
DN8155	7.14	7.94	16.0	12.0	5.68
DN1047	9.40	10.40	24.0	12.0	4.80
DN1058	9.50	10.50	24.0	12.0	5.90

Customer Packaging Specifications
For Print Distribution to Customers

Series	Revision
DN SERIES	B
Sheet 2 of 3	

Item	Specification	Test Method/Condition
Environmental		
Static Humidity	After exposure part remains within specified electrical parameters for L, Q and DCR.	Expose parts to an environment of +50°C with 90 to 95% R.H. for 100 hours. After exposure, allow parts to dry for 2 hours before measurements are taken.
Storage Life	After exposure part remains within specified electrical parameters for L, Q and DCR.	Subject parts to an environment of +50°C 90 to 100% R.H. for 46 to 50 hours. After exposure, allow parts to dry for 2 hours before measurements are taken.
Moisture Resistance	After exposure, part shall not have a shorted or open winding.	Per MIL-STD 202 Method 106, ten 24 hour cycles at +25°C to +65°C at 80 to 95% R.H. During any of the first 9 cycles, inductors are revolved from the chamber and exposed to -10°C for 3 hours. Allow parts to dry for 2 hours before measurements are taken.
Temperature Cycle	After exposure part remains within specified electrical parameters for L, Q and DCR.	10 cycles (Air to Air) 1 cycle shall consist of: 30 minutes exposure to +85°C 30 minutes exposure to -40°C Allow 20 minutes transition between extremes.
Temperature Shock	After exposure part remains within specified electrical parameters for L, Q and DCR.	10 cycles (Air to Air) 1 cycle shall consist of: 30 minutes exposure to -45°C 30 minutes exposure to +125°C 15 seconds maximum transition between temperatures
General		
Storage Temperature Range	-40°C to +85°C	
Operating Temperature Range	-40°C to +85°C	
Flammability	IEC 695-2-2	Withstands needle-flame test
Other		
Vibration	After exposure part remains within specified electrical parameters for L, Q and DCR.	Inductors shall be randomly vibrated per NAVMAT P9492 profile. Samples shall be subjected to 0.04G/Hz for a minimum of 15 minutes per axis, for each of the three axes.
Mechanical Shock	After exposure part remains within specified electrical parameters for L, Q and DCR.	Test per MIL-STD 202 method 213 test condition A, test mounted samples 3 axes, 6 times, totaling 18 shocks. (50Gs, 11ms, half-sine).
Solderability	Wetting shall cover 90% minimum of each termination	Dip pads in RMA flux, 63/37 solder (Sn/Pb) at 232°C for 5 seconds ±2 seconds.
Component Adhesion (Push Test)	4 pounds	Apply and measure force with a digital force gauge set.
Resistance to Solvent	No sign of degradation in appearance or marking detail.	Withstands 6 minutes of alcohol. Withstands 3 minutes forced spray Freon TMS
Load Life	After exposure, part shall not have a shorted or open winding.	Parts to be stored at 110°C for 1000 hours with rated current applied. Parts to be tested at: start, 500 and 1000 hours. Allow 2 hours at room temperature before testing.

For Print Distribution to Customers	Series	Revision
	DN SERIES	B
	Sheet 3 of 3	