

■ OVERVIEW

The SM1140 series is the CMOS IC that can play enveloped melodies with two sound sources. Adopting digital envelope realizes low-cost, high-quality sound system with less number of external component.

■ FEATURES

- Maximum play ROM amount: 127 words
- Maximum number of jump: 31 times
- Number of play: max. 4 tunes
- Play starts by D C trigger at power-on
- Built-in digital envelope
- Main melody accompaniment are independently output with 30 musical scales.
- Play mode is level-hold playing mode
- Wide range of supply voltage: 1.2 to 5.5V

■ MARKING and PACKAGE

1140	Package	Marking
SM1140 x x P	8-pin DIP	SM1140 x x
SM1140 x x S	8-pin SOP	140 x x

x x : version name

■ EXTERNAL DIMENSIONS

•8-PIN DIP

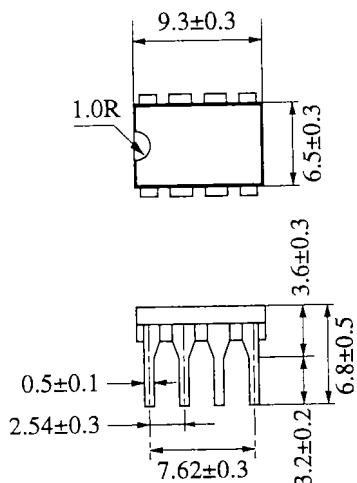

UNIT: mm

•8-PIN SOP

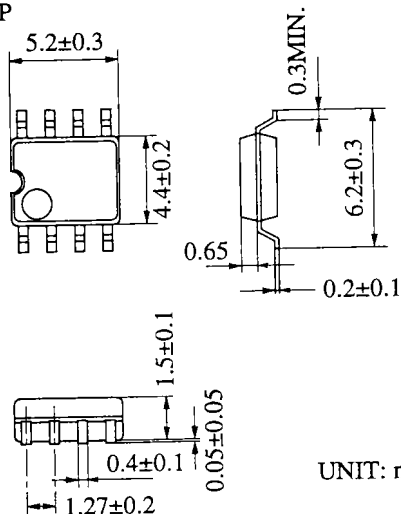

UNIT: mm

■ PIN DESCRIPTIONS

No.	Symbol	Function
1	OSC1	Resistor connecting pins for oscillation normally connecting 470kΩ resistor starts oscillation.
2	OSC2	
3	V _{SS}	Ground
4	T1	Test pin input. Internal pull-down resistor.
5	T01	Test output. Oscillation frequency (Typ 32.768KHz) can be monitored at this pin.
6	T02	Test output
7	MTO	Play signal output
8	V _{DD}	Supply pin +1.2 to +5.5V

■ PIN OUT

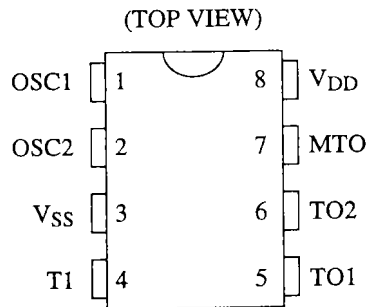

■ ABSOLUTE MAXIMUM RATINGS

Item	Symbol	Ratings	Unit
Supply voltage	V _{DD} -V _{SS}	-0.3 to 7.0	V
Input voltage	V _{IN}	V _{SS} -0.2 < V _{IN} < V _{DD} +0.2	V
Operating temp.	T _{OPR}	-20 to +80	°C
Storage temp.	T _{STG}	-55 to +125	°C
Soldering temp.	T _{SLD}	260 ± 5	°C
Soldering time	t _{SLD}	10	Sec.

■ ELECTRICAL CHARACTERISTICS

Ta=250°C, Vss=0V, VDD=1.5V

Item	Symbol	Condition	Rating			Unit	Note
			Min.	Typ.	Max.		
Supply voltage	V _{DD}		1.2	1.5	5.5	V	
Current consumption	I _{DD}	MTO=OPEN		200	400	μA	
Input current	I _{IH}	V _{IH} =1.5V			0.1	μA	OSC1 pin
	I _{IL}	V _{IL} =0V			0.1	μA	
Input oscillation width	V _{osc}	When external clock input V _{DD} ≥1.5V	V _{DD} /2 ±0.4			V	OSC1 pin
Oscillation frequency variation	f _{osc}	External R=470kΩ	-20		+20	%	
Frequency stability	Δf/f	f _{osc} =32.768KHz			1	%/0.1V	

■ APPLICATION CIRCUIT

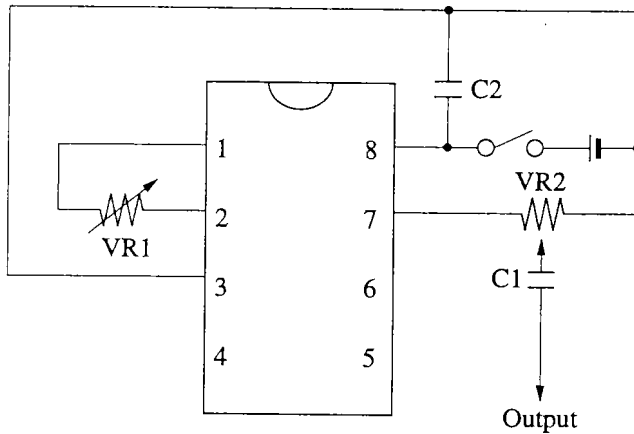

VR1 : 500 kΩ

VR2 : 50 kΩ

C1 : Determine due to next stage input Impedance

C2: by-pass capacitor 0.1 μF or more

FUNCTION SPECIFICATIONS

1. Play type

Play type is the level-hold playing mode in which play continues while power is on.

2. Play start timing

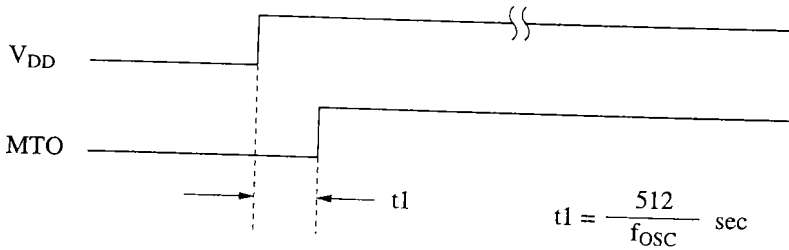

3. Digital envelope

In line with the previously programmed quasi-exponent curve, main melody and accompaniment are enveloped independently. Envelope waveform is shown as follows.

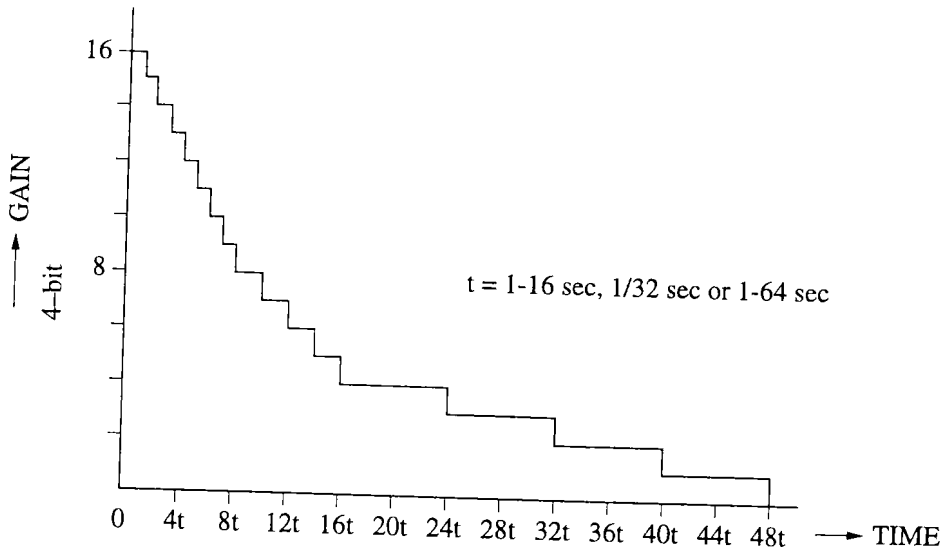

Envelope waveform

■ MUSICAL SPECIFICATIONS

1. Maximum number of program steps

Maximum 127 steps can be mask-programmed into the internal ROM. Within 1 step interval length, tie and rest of tone 1 and 2 can be specified.

2. Length (including rest)

8 kinds among 16th note (rest) to half note (rest) can be used.

	0	1	2	3	4	5	6	7
NOTE								
REST								

A note or rest longer than a half note (rest) can be made by combining 2 pieces of sound using tie. In this case 2 steps of ROM are needed.

3. Tempo

One kind among the following 32 can be selected.

	0	1	2	3	4	5	6	7
=	1280.0	640.0	426.7	320.0	256.0	213.3	182.9	160.0
	8	9	A	B	C	D	E	F
	142.2	128.0	116.4	106.7	98.5	91.4	85.3	80.0
	10	11	12	13	14	15	16	17
	75.3	71.1	67.4	64.0	61.0	58.2	55.7	53.3
	18	19	1A	1B	1C	1D	1E	1F
	51.2	49.2	47.4	45.7	44.1	42.7	41.3	40.0

4. Compass and scale

As for tune 1 and 2, 30 kinds of sound can be selected as scale from among 3 octaves of either C4 ~ C7 or C3 ~ C6 by mask-selection. The scale ranges of tune 1 and 2 do not have to be identical.

■ OUTPUT MUSICAL SCALE 1

Scale output standard clock-freq. =32.768KHz

Name	Output Frequency	Standard Frequency	Error (cent)	Data
C3	131.072	130.813	3.43	FA
C#3	138.847	138.591	3.20	EC
D3	146.942	146.832	1.29	DF
D#3	155.299	155.563	-2.95	D3
E3	164.663	164.814	-1.58	C7
F3	174.298	174.614	-3.14	BC
F#3	185.130	184.997	1.24	B1
G3	196.216	195.998	1.92	A7
G#3	207.392	207.652	-2.17	9E
A3	219.919	220.000	-0.63	95
A#3	232.397	233.082	-5.09	8D
B3	246.376	246.942	-3.97	85
C4	262.144	261.625	3.43	7D
C#4	277.695	277.183	3.20	76
D4	292.571	293.665	-6.46	70
D#4	312.076	311.127	5.27	69
E4	330.990	329.627	7.14	63
F4	348.596	349.228	-3.14	5E
F#4	368.180	369.994	-8.51	59
G4	390.095	391.995	-8.41	54
G#4	414.785	415.305	-2.17	4F
A4	442.811	440.000	11.02	4A
A#4	468.114	466.164	7.23	46
B4	496.485	493.883	9.10	42
C5	520.127	523.251	-10.37	3F
C#5	555.390	554.365	3.20	3B
D5	585.143	587.330	-6.46	38
D#5	618.264	622.254	-11.14	35
E5	655.360	659.255	-10.26	32
F5	697.191	698.457	-3.14	2F
F#5	744.727	739.989	11.05	2C
G5	780.190	783.991	-8.41	2A
G#5	840.205	830.610	19.88	27
A5	885.622	880.000	11.02	25
A#5	936.229	932.328	7.23	23
B5	992.970	987.767	9.09	21
C6	1057.03	1046.50	17.33	1F

Scale output standard clock-freq. 65.536KHz

Name	Output Frequency	Standard Frequency	Error (cent)	Data
C4	262.144	261.625	3.43	FA
C#4	277.695	277.183	3.20	EC
D4	293.883	293.665	1.29	DF
D#4	310.597	311.127	-2.95	D3
E4	329.327	329.627	-1.58	C7
F4	348.596	349.228	-3.14	BC
F#4	370.260	369.994	1.24	B1
G4	392.431	391.995	1.92	A7
G#4	414.785	415.305	-2.17	9E
A4	439.839	440.000	-0.63	95
A#4	464.794	466.164	-5.09	8D
B4	492.752	493.883	-3.97	84
C5	524.288	523.251	3.43	7D
C#5	555.390	554.365	3.20	76
D5	585.143	587.330	-6.46	70
D#5	624.152	622.254	5.27	69
E5	661.980	659.255	7.14	63
F5	697.191	698.457	-3.14	5E
F#5	736.360	739.989	-8.51	59
G5	780.190	783.991	-8.41	54
G#5	829.570	830.610	-2.17	4F
A5	885.622	880.000	11.02	4A
A#5	936.229	932.328	7.23	46
B5	992.970	987.767	9.09	42
C6	1040.25	1046.50	-10.37	3F
C#6	1110.78	1108.73	3.20	3B
D6	1170.29	1174.66	-6.46	38
D#6	1236.53	1244.51	-11.14	35
E6	1310.72	1318.51	-10.26	32
F6	1394.38	1396.91	-3.14	2F
F#6	1489.45	1479.98	11.05	2C
G6	1560.38	1567.98	-8.41	2A
G#6	1680.41	1661.22	19.88	27
A6	1771.24	1760.00	11.02	25
A#6	1872.46	1864.66	7.23	23
B6	1985.94	1975.54	9.09	21
C7	2114.06	2093.01	17.33	1F