

DATA SHEET

PDI1394P21

3-port physical layer interface

Objective specification

1999 Jul 09

3-port physical layer interface

PDI1394P21

1.0 FEATURES

- Fully supports provisions of IEEE 1394–1995 Standard for high performance serial bus and the P1394a supplement (Version 2.0)¹
- Full P1394a support includes:
 - Connection debounce
 - Arbitrated short reset
 - Multispeed concatenation
 - Arbitration acceleration
 - Fly-by concatenation
 - Port disable/suspend/resume
- Provides three 1394a fully-compliant cable ports at 100/200/400 Megabits per second (Mbits/s)
- Fully compliant with Open HCI requirements
- Cable ports monitor line conditions for active connection to remote node.
- Power down features to conserve energy in battery-powered applications include:
 - Automatic device power down during suspend
 - Device power down terminal
 - Link interface disable via LPS
 - Inactive ports powered-down
- Logic performs system initialization and arbitration functions
- Encode and decode functions included for data-strobe bit level encoding
- Incoming data resynchronized to local clock
- Single 3.3 volt supply operation
- Minimum V_{DD} of 2.7 V for end-of-wire power-consuming devices
- While unpowered and connected to the bus, will not drive TPBIAS on a connected port, even if receiving incoming bias voltage on that port
- Supports extended bias-handshake time for enhanced interoperability with camcorders

- Interface to link-layer controller supports low-cost bus-holder isolation and optional Annex J electrical isolation
- Data interface to link-layer controller through 2/4/8 parallel lines at 49.152 MHz
- Low-cost 24.576 MHz crystal provides transmit, receive data at 100/200/400 Mbits/s, and link-layer controller clock at 49.152 MHz
- Does not require external filter capacitors for PLL
- Interoperable with link-layer controllers using 3.3 V and 5 V supplies
- Interoperable with other Physical Layers (PHYs) using 3.3 V and 5 V supplies
- Node power class information signaling for system power management
- Cable power presence monitoring
- Separate cable bias (TPBIAS) for each port
- Register bits give software control of contender bit, power class bits, link active bit, and 1394a features
- Fully interoperable with FireWire™ implementation of IEEE Std 1394
- Function and pin compatible with the Texas Instruments 400 Mbps Phy TSB41LV03™

2.0 DESCRIPTION

The PDI1394P21 provides the digital and analog transceiver functions needed to implement a three port node in a cable-based IEEE 1394–1995 and/or 1394a network. Each cable port incorporates two differential line transceivers. The transceivers include circuitry to monitor the line conditions as needed for determining connection status, for initialization and arbitration, and for packet reception and transmission. The PDI1394P21 is designed to interface with a Link Layer Controller (LLC), such as the PDI1394L11 or PDI1394L21.

3.0 ORDERING INFORMATION

PACKAGE	TEMPERATURE RANGE	OUTSIDE NORTH AMERICA	NORTH AMERICA	PKG. DWG. #
80-pin plastic LQFP	0°C to +70°C	PDI1394P21 BE	PDI1394P21 BE	SOT315-1

1. Implements technology covered by one or more patents of Apple Computer, Incorporated and SGS Thompson, Limited.

3-port physical layer interface

PDI1394P21

4.0 PIN CONFIGURATION

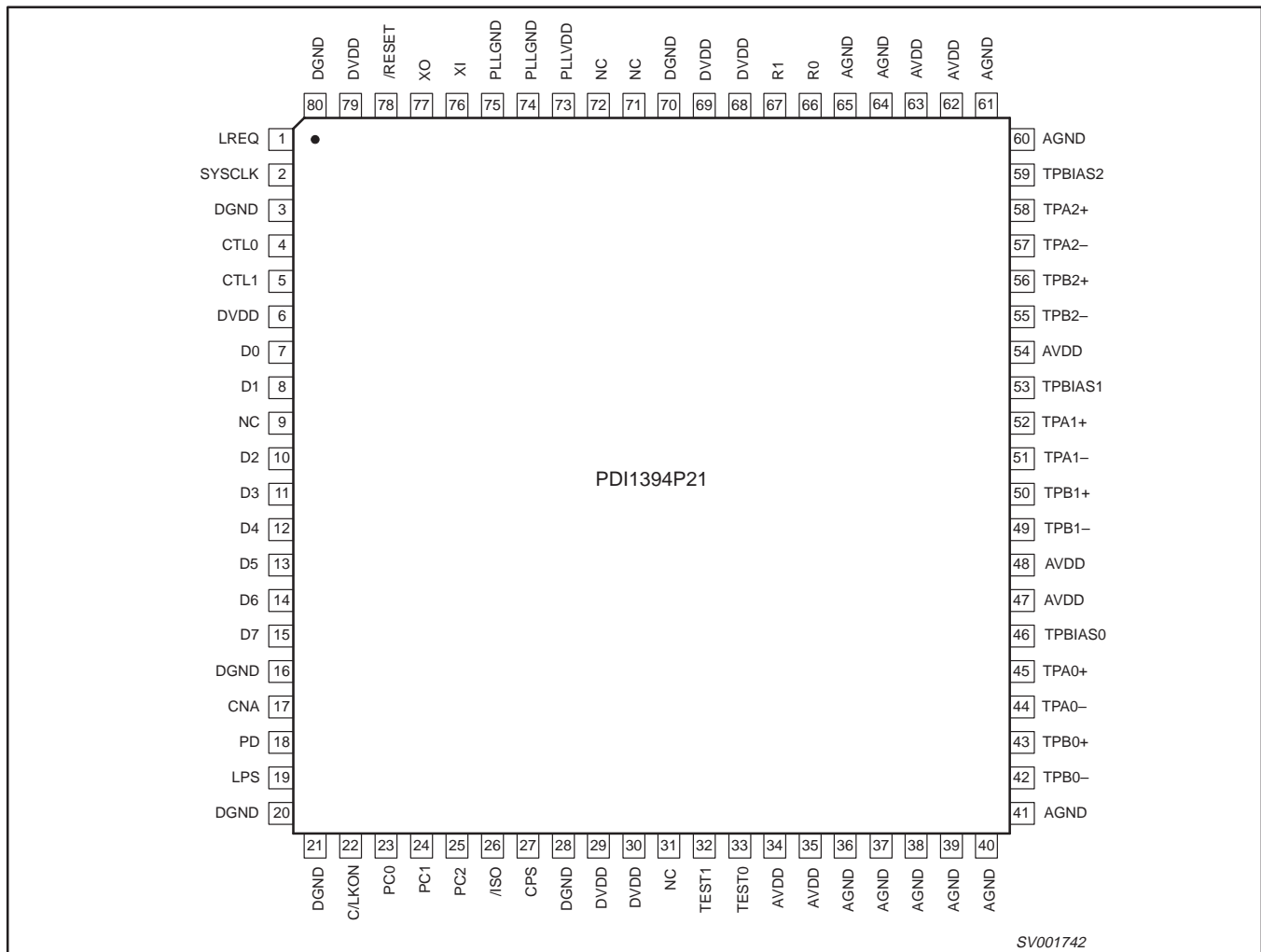

5.0 PIN DESCRIPTION

Name	Pin Type	Pin Numbers	I/O	Description
AGND	Supply	36, 37, 38, 39, 40, 41, 60, 61, 64, 65	—	Analog circuit ground terminals. These terminals should be tied together to the low impedance circuit board ground plane.
AVDD	Supply	34, 35, 47, 48, 54, 62, 63	—	Analog circuit power terminals. A combination of high frequency decoupling capacitors near each terminal are suggested, such as paralleled 0.1 μ F and 0.001 μ F. Lower frequency 10 μ F filtering capacitors are also recommended. These supply terminals are separated from PLLVDD and DVDD internal to the device to provide noise isolation. They should be tied to a low impedance point on the circuit board.
CNA	CMOS	17	O	Cable Not Active output. This terminal is asserted high when there are no ports receiving incoming bias voltage.
CPS	CMOS	27	I	Cable Power Status input. This terminal is normally connected to cable power through a 370–410 k Ω resistor. This circuit drives an internal comparator that is used to detect the presence of cable power.
CTL0, CTL1	CMOS 5V tol	4, 5	I/O	Control I/Os. These bi-directional signals control communication between the PDI1394P21 and the LLC. Bus holders are built into these terminals.

3-port physical layer interface

PDI1394P21

Name	Pin Type	Pin Numbers	I/O	Description
C/LKON	CMOS 5V tol	22	I/O	Bus Manager Contender programming input and link-on output. On hardware reset, this terminal is used to set the default value of the contender status indicated during self-ID. Programming is done by tying the terminal through a 10kΩ resistor to a high (contender) or low (not contender). The resistor allows the link-on output to override the input. Following hardware reset, this terminal is the link-on output, which is used to notify the LLC to power-up and become active. The link-on output is a square-wave signal with a period of approximately 163 ns (8 SYSCLK cycles) when active. The link-on output is deasserted low when the LPS input terminal is active.
DGND	Supply	3, 16, 20, 21, 28, 70, 80	—	Digital circuit ground terminals. These terminals should be tied together to the low impedance circuit board ground plane.
D0–D7	CMOS 5V tol	7, 8, 10, 11, 12, 13, 14, 15	I/O	Data I/Os. These are bi-directional data signals between the PDI1394P21 and the LLC. Bus holders are built into these terminals.
DVDD	Supply	6, 29, 30, 68, 69, 79	—	Digital circuit power terminals. A combination of high frequency decoupling capacitors near each terminal are suggested, such as paralleled 0.1 μF and 0.001 μF. Lower frequency 10 μF filtering capacitors are also recommended. These supply terminals are separated from PLLVDD and AVDD internal to the device to provide noise isolation. They should be tied at a low impedance point on the circuit board.
/ISO	CMOS	26	I	Link interface isolation control input. This terminal controls the operation of output differentiation logic on the CTL and D terminals. If an optional isolation barrier of the type described in Annex J of IEEE Std 1394–1395 is implemented between the PDI1394P21 and LLC, the /ISO terminal should be tied low to enable the differentiation logic. If no isolation barrier is implemented (direct connection), or bus holder isolation is implemented, the /ISO terminal should be tied high to disable the differentiation logic.
LPS	CMOS 5V tol	19	I	Link Power Status input. This terminal is used to monitor the power status of the LLC, and is connected to either the V _{DD} supplying the link layer controller through a 1kΩ resistor, or to a pulsed output which is active when the LLC is powered. The pulsed output is useful when using an isolation barrier. If this input is low for more than 25 μs, the LLC is considered powered down. If this input is high for more than 20 ns, the LLC is considered powered up. If the LLC is powered-down, the PHY–LLC interface is disabled, and the PDI1394P21 performs only the basic repeater functions required for network initialization and operation. Bus holder is built into this terminal.
LREQ	CMOS 5V tol	1	I	LLC Request input. The LLC uses this input to initiate a service request to the PDI1394P21. Bus holder is built into this terminal.
NC	No Connect	9, 31, 71, 72	—	These pins are not internally connected, and consequently are “don’t cares”. Other vendor’s pin compatible chips may require connections and external circuitry on these pins.
PC0, PC1, PC2	CMOS 5V tol	23, 24, 25	I	Power Class programming inputs. On hardware reset, these inputs set the default value of the power class indicated during self-ID. Programming is done by tying the terminals high or low. Refer to Table 18 for encoding.
PD	CMOS 5V tol	18	I	Power Down input. A logic high on this terminal turns off all internal circuitry except the cable-active monitor circuits which control the CNA output. Bus holder is built into this terminal. For more information, refer to Section 17.3
PLLGND	Supply	74, 75	—	PLL circuit ground terminals. These terminals should be tied together to the low impedance circuit board ground plane.
PLLVDD	Supply	73	—	PLL circuit power terminals. A combination of high frequency decoupling capacitors near each terminal are suggested, such as paralleled 0.1 μF and 0.001 μF. Lower frequency 10 μF filtering capacitors are also recommended. These supply terminals are separated from DVDD and AVDD internal to the device to provide noise isolation. They should be tied at a low impedance point on the circuit board.

3-port physical layer interface

PDI1394P21

Name	Pin Type	Pin Numbers	I/O	Description
/RESET	CMOS 5V tol	78	I	Logic reset input. Asserting this terminal low resets the internal logic. An internal pull-up resistor to V_{DD} is provided so only an external delay capacitor in parallel with a resistor is required for proper power-up operation. For more information, refer to Section 17.3. This input is otherwise a standard logic input, and can also be driven by an open-drain type driver.
R0, R1	Bias	66, 67	—	Current setting resistor terminals. These terminals are connected to an external resistance to set the internal operating currents and cable driver output currents. A resistance of $6.34 \text{ k}\Omega \pm 1\%$ is required to meet the IEEE Std 1394–1995 output voltage limits.
SYSCLK	CMOS	2	O	System clock output. Provides a 49.152 MHz clock signal, synchronized with data transfers, to the LLC.
TEST0	CMOS	33	I	Test control input. This input is used in manufacturing tests of the PDI1394P21. For normal use, this terminal should be tied to GND.
TEST1	CMOS	32	I	Test control input. This input is used in manufacturing tests of the PDI1394P21. For normal use, this terminal should be tied to GND.
TPA0+, TPA1+, TPA2+	Cable	45, 52, 58	I/O	Twisted-pair cable A differential signal terminals. Board traces from each pair of positive and negative differential signal terminals should be kept matched and as short as possible to the external load resistors and to the cable connector.
TPA0–, TPA1–, TPA2–	Cable	44, 51, 57	I/O	
TPB0+, TPB1+, TPB2+	Cable	43, 50, 56	I/O	Twisted-pair cable B differential signal terminals. Board traces from each pair of positive and negative differential signal terminals should be kept matched and as short as possible to the external load resistors and to the cable connector.
TPB0–, TPB1–, TPB2–	Cable	42, 49, 55	I/O	
TPBIAS0, TPBIAS1, TPBIAS2	Cable	46, 53, 59	I/O	Twisted-pair bias output. This provides the 1.86V nominal bias voltage needed for proper operation of the twisted-pair cable drivers and receivers, and for signaling to the remote nodes that there is an active cable connection. Each of these terminals must be decoupled with a $0.3 \mu\text{F}$ – $1 \mu\text{F}$ capacitor to ground.
XO, XI	Crystal	77, 76	—	Crystal oscillator inputs. These terminals connect to a 24.576 MHz parallel resonant fundamental mode crystal. The optimum values for the external shunt capacitors are dependent on the specifications of the crystal used. Can also be driven by an external clock generator (leave XO unconnected in this case).

3-port physical layer interface

PDI1394P21

6.0 BLOCK DIAGRAM

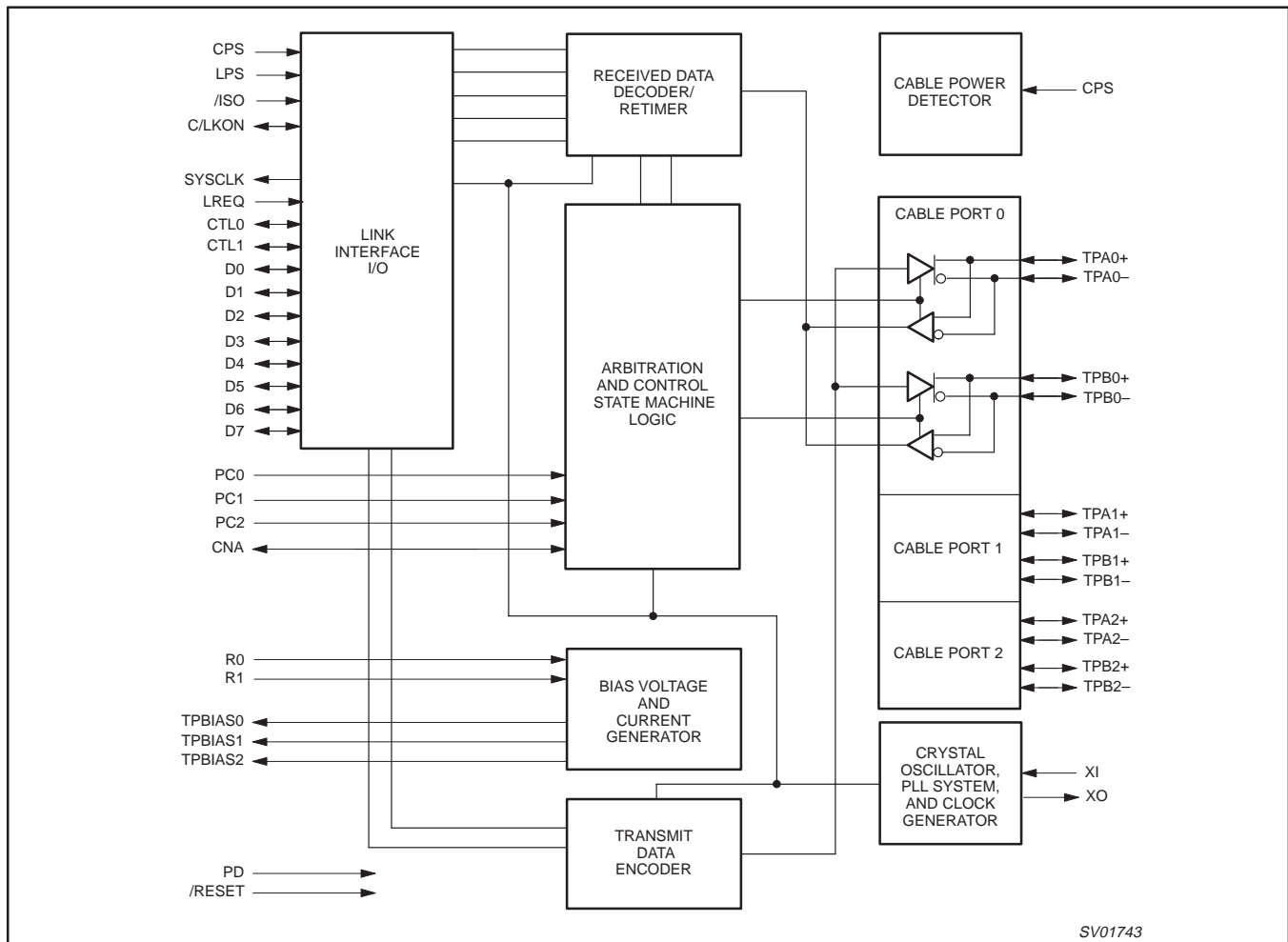

7.0 FUNCTIONAL SPECIFICATION

The PDI1394P21 requires only an external 24.576 MHz crystal as a reference. An external clock can be provided instead of a crystal. An internal oscillator drives an internal phase-locked loop (PLL), which generates the required 393.216 MHz reference signal. This reference signal is internally divided to provide the clock signals used to control transmission of the outbound encoded Strobe and Data information. A 49.152 MHz clock signal, supplied to the associated LLC for synchronization of the two chips, is used for resynchronization of the received data. The Power Down (PD) function, when enabled by asserting the PD terminal high, stops operation of the PLL and disables all circuits except the cable bias detectors at the TPB terminals. The port transmitter circuitry and the receiver circuitry are also disabled when the port is disabled, suspended, or disconnected.

The PDI1394P21 supports an optional isolation barrier between itself and its LLC. When the /ISO input terminal is tied high, the LLC interface outputs behave normally. When the /ISO terminal is tied low, internal differentiating logic is enabled, and the outputs are driven such that they can be coupled through a capacitive or transformer galvanic isolation barrier as described in *IEEE 1394a*

section 5.9.4. To operate with single capacitor (bus holder) isolation, the /ISO on the PHY terminal must be tied high.

Data bits to be transmitted through the cable ports are received from the LLC on two, four or eight parallel paths (depending on the requested transmission speed). They are latched internally in the PDI1394P21 in synchronization with the 49.152 MHz system clock. These bits are combined serially, encoded, and transmitted at 98.304/196.608/392.216 Mbits/s (referred to as S100, S200, and S400 speed, respectively) as the outbound data-strobe information stream. During transmission, the encoded data information is transmitted differentially on the TPB cable pair(s), and the encoded strobe information is transmitted differentially on the TPA cable pair(s).

During packet reception the TPA and TPB transmitters of the receiving cable port are disabled, and the receivers for that port are enabled. The encoded data information is received on the TPA cable pair, and the encoded strobe information is received on the TPB cable pair. The received data-strobe information is decoded to recover the receive clock signal and the serial data bits. The serial

3-port physical layer interface

PDI1394P21

data bits are split into two-, four- or eight-bit parallel streams (depending upon the indicated receive speed), resynchronized to the local 49.152 MHz system clock and sent to the associated LLC. The received data is also transmitted (repeated) on the other active (connected) cable ports.

Both the TPA and TPB cable interfaces incorporate differential comparators to monitor the line states during initialization and arbitration. The outputs of these comparators are used by the internal logic to determine the arbitration status. The TPA channel monitors the incoming cable common-mode voltage. The value of this common-mode voltage is used during arbitration to set the speed of the next packet transmission (speed signalling). In addition, the TPB channel monitors the incoming cable common-mode voltage on the TPB pair for the presence of the remotely supplied twisted-pair bias voltage (cable bias detection).

The PDI1394P21 provides a 1.86 V nominal bias voltage at the TPBIAS terminal for port termination. The PHY contains three independent TPBIAS circuits. This bias voltage, when seen through a cable by a remote receiver, indicates the presence of an active connection. This bias voltage source must be stabilized by an external filter capacitor of 0.3 μF –1 μF .

The line drivers in the PDI1394P21 operate in a high-impedance current mode, and are designed to work with external 112 Ω line-termination resistor networks in order to match the 110 Ω cable impedance. One network is provided at each end of all twisted-pair cable. Each network is composed of a pair of series-connected 56 Ω resistors. The midpoint of the pair of resistors that is directly connected to the twisted-pair A terminals is connected to its corresponding TPBIAS voltage terminal. The midpoint of the pair of resistors that is directly connected to the twisted-pair B terminals is coupled to ground through a parallel R-C network with recommended values of 5 k Ω and 220 pF. The values of the external line termination resistors are designed to meet the standard specifications when connected in parallel with the internal receiver circuits. An external resistor connected between the R0 and R1 terminals sets the driver output current, along with other internal operating currents. This current setting resistor has a value of 6.34 k Ω \pm 1%.

When the power supply of the PDI1394P21 is removed while the twisted-pair cables are connected, the PDI1394P21 transmitter and receiver circuitry presents a high impedance to the cable in order to not load the TPBIAS voltage on the other end of the cable.

When the PDI1394P21 is used with one or more of the ports not brought out to a connector, the twisted-pair terminals of the unused ports must be terminated for reliable operation. For each unused port, the TPB+ and TPB– terminals can be tied together and then pulled to ground, or the TPB+ and TPB– terminals can be connected to the suggested termination network. The TPA+ and TPA– and TPBIAS terminals of an unused port can be left unconnected.

The TEST0 and TEST1 terminals are used to set up various manufacturing test conditions. For normal operation, the TEST0 and TEST1 terminals should be connected to ground.

Four package terminals, used as inputs to set the default value for four configuration status bits in the self-ID packet, should be

hard-wired high or low as a function of the equipment design. The PC0–PC2 terminals are used to indicate the default power-class status for the node (the need for power from the cable or the ability to supply power to the cable). See Table 18 for power class encoding. The C/LKON terminal is used as an input to indicate that the node is a contender for bus manager.

The PHY supports suspend/resume as defined in the IEEE 1394a specification. The suspend mechanism allows pairs of directly connected ports to be placed into a low power state while maintaining a port-to-port connection between 1394 bus segments. While in a low power state, a port is unable to transmit or receive data transaction packets. However, a port in a low power state is capable of detecting connection status changes and detecting incoming TPBIAS. When all three ports of the PDI1394P21 are suspended, all circuits except the bias-detection circuits are powered down, resulting in significant power savings. The TPBIAS circuit monitors the value of incoming TPA pair common-mode voltage when local TPBIAS is inactive. Because this circuit has an internal current source and the connected node has a current sink, the monitored value indicates the cable connection status. This monitor is called connect-detect.

Both the cable bias-detect monitor and TPBIAS connect-detect monitor are used in suspend/resume signaling and cable connection detection. For additional details of suspend/resume operation, refer to the 1394a specification. The use of suspend/resume is recommended for new designs.

The port transmitter and receiver circuitry is disabled during power down (when the PD input terminal is asserted high), during reset (when the /RESET input terminal is asserted low), when no active cable is connected to the port, or when controlled by the internal arbitration logic. The port twisted-pair bias voltage circuitry is disabled during power down, during reset, or when the port is disabled as commanded by the LLC.

The CNA (cable-not-active) terminal provides a high output when all twisted-pair cable ports are disconnected, and can be used along with LPS to determine when to power down the PDI1394P21. The CNA output is not debounced. In Power Down mode, the CNA detection circuitry remains enabled.

The LPS (link power status) terminal works with the C/LKON terminal to manage the power usage in the node. The LPS signal from the LLC indicates to the PHY that the LLC is powered up and active. During LLC Power Down mode, as indicated by the LPS input being low for more than 25 μs , the PDI1394P21 deactivates the PHY-LLC interface to save power. The PDI1394P21 continues the necessary repeater function required for network operation during this low power state.

If the PHY receives a link-on packet from another node, the C/LKON terminal is activated to output a square-wave signal. The LLC recognizes this signal, reactivates any powered-down portions of the LLC, and notifies the PHY of its power-on status via the LPS terminal. The PHY confirms notification by deactivating the square-wave signal on the C/LKON terminal, then enables the PHY-link interface.

3-port physical layer interface

PDI1394P21

8.0 ABSOLUTE MAXIMUM RATINGS 1

In accordance with the Absolute Maximum Rating System (IEC 134). Voltages are referenced to GND (ground = 0 V).

SYMBOL	PARAMETER	CONDITION	LIMITS		UNIT
			MIN	MAX	
V_{DD}	DC supply voltage		-0.5	4.0	V
V_I	DC input voltage		-0.5	$V_{DD}+0.5$	V
V_{I-5V}	5 volt tolerant input voltage range		-0.5	5.5	V
V_O	DC output voltage range at any output		-0.5	$V_{DD}+0.5$	V
	Electrostatic discharge	Human Body Model		2	kV
		Machine Model		200	V
T_{amb}	Operating free-air temperature range		0	+70	°C
T_{stg}	Storage temperature range		-65	+150	°C

NOTE:

- Stresses beyond those listed under "Absolute Maximum Ratings" may cause permanent damage to the device. These are stress ratings only, and functional operation of the device at these or any other conditions beyond those indicated under "Recommended Operating Conditions" is not implied. Exposure to absolute-maximum-rated conditions for extended periods may affect device reliability.

9.0 RECOMMENDED OPERATING CONDITIONS

SYMBOL	PARAMETER		MIN	TYP	MAX	UNIT	
V_{DD}	Supply voltage	Source power node	3.0	3.3	3.6	V	
		Non-source power node	2.7 ¹	3.0	3.6	V	
V_{IH}	High-level input voltage, pins CTLn, Dn, C/LKON ²	/ISO = V_{DD} , $V_{DD} = 2.7$ V	2.3		5.5	V	
		/ISO = V_{DD} , $V_{DD} \geq 3.0$ V	2.6		5.5	V	
V_{IL}	Low-level input voltage, pins CTLn, Dn, C/LKON ²	/ISO = V_{DD}			0.7	V	
I_{OH}/I_{OL}	Output current, pins CTLn, Dn, C/LKON and SYSCLK	$V_{OH} = V_{DD} - 0.5$ V, $V_{OL} = 0.5$ V	-12		12	mA	
I_O	Output current	TPBIAS outputs	-6		2.5	mA	
V_{ID}	Differential input voltage amplitude	TPA, TPB cable inputs, during data reception	118		260	mV	
		TPA, TPB cable inputs, during data arbitration	168		265	mV	
V_{IC-100}	TPB common-mode input voltage	Speed signalling off or S100 speed signal	Source power node	1.165		2.515	V
			Non-source power node	1.165		2.015 ¹	V
V_{IC-200}	TPB common-mode input voltage	S200 speed signal	Source power node	0.935		2.515	V
			Non-source power node	0.935		2.015 ¹	V
V_{IC-100}	TPB common-mode input voltage	S400 speed signal	Source power node	0.523		2.515	V
			Non-source power node	0.523		2.015 ¹	V
t_{PU}	Power-up reset time	Set by capacitor between /RESET pin and GND	2			ms	
	Receive input jitter	TPA, TPB cable inputs, S100 operation			1.08	ns	
		TPA, TPB cable inputs, S200 operation			0.5	ns	
		TPA, TPB cable inputs, S400 operation			0.315	ns	
	Receive input skew	Between TPA and TPB cable inputs, S00 operation			0.8	ns	
		Between TPA and TPB cable inputs, S200 operation			0.55	ns	
		Between TPA and TPB cable inputs, S400 operation			0.5	ns	
f_{XTAL}	Crystal or external clock frequency	Crystal connected according to Figure 8 or external clock input at pin XI	24.5735	24.576	24.5785	MHz	

NOTES:

- For a node that does not source power to the bus (see Section 4.2.2.2 in the IEEE 1394-1995 standard).
- C/LKON is only an input when /RESET = 0.

3-port physical layer interface

PDI1394P21

10.0 CABLE DRIVER

SYMBOL	PARAMETER	TEST CONDITION	LIMITS			UNIT
			MIN	TYP	MAX	
V _{OD}	Differential output voltage	56 Ω load	172		265	mV
I _{O(diff)}	Driver Difference current, TPA+, TPA-, TPB+, TPB- ¹	Drivers enabled, speed signaling OFF	-1.05 ¹		0.88 ¹	mA
I _{SP}	Common mode speed signaling current, TPB+, TPB- ²	100 Mbit/s speed signaling enabled	-0.81		-0.44	mA
		200 Mbit/s speed signaling enabled	-4.84		-2.53	mA
		400 Mbit/s speed signaling enabled	-12.4		-8.10	mA
V _{OFF}	OFF state differential voltage	Drivers disabled			20	mV

NOTES:

- Limits defined as algebraic sum of TPA+ and TPA- driver currents. Limits also apply to TPB+ and TPB- algebraic sum of driver currents.
- Limits defined as absolute limit of each of TPB+ and TPB- driver currents.

11.0 CABLE RECEIVER

SYMBOL	PARAMETER	TEST CONDITION	LIMITS			UNIT
			MIN	TYP	MAX	
Z _{ID}	Differential input impedance	Drivers disabled	10	14		kΩ
					4	pF
Z _{IC}	Common mode input impedance	Drivers disabled	20			kΩ
					24	pF
V _{TH-R}	Receiver input threshold voltage	Drivers disabled	-30		30	mV
V _{TH-CB}	Cable bias detect threshold, TPBn cable inputs	Drivers disabled	0.6		1.0	V
V _{TH+}	Positive arbitration comparator threshold voltage	Drivers disabled	89		168	mV
V _{TH-}	Negative arbitration comparator threshold voltage	Drivers disabled	-168		-89	mV
V _{TH-SP200}	Speed signal threshold	TPBIAS-TPA common mode voltage, drivers disabled	49		131	mV
V _{TH-SP400}	Speed signal threshold	TPBIAS-TPA common mode voltage, drivers disabled	314		396	mV
I _{CD}	Connect detect output at TPBIAS pins	Drivers disabled			76	μA

3-port physical layer interface

PDI1394P21

12.0 OTHER DEVICE I/O

SYMBOL	PARAMETER	TEST CONDITION	MIN	TYP	MAX	UNIT
I _{DD}	Supply current	Peak ¹			tbf	mA
		Transmit ²		tbf		mA
		Repeat ³		tbf		mA
		Idle ⁴		tbf		mA
I _{DD-PD}	Supply current in power down or suspend mode	PD = V _{DD} in power down mode		tbf	tbf	mA
V _{TH}	Cable power status threshold voltage	370 kΩ–400 kΩ resistor between cable power and CPS pin: Measured at cable power side of resistor	7.5	8.0	8.5	V
V _{OH}	High-level output voltage. pins CTLn, Dn, SYSCLK, CNA, C/LKON	V _{DD} ≥ 2.7 V, I _{OH} = –4 mA, /ISO = V _{DD}	2.2			V
		V _{DD} ≥ 3.0 V, I _{OH} = –4 mA, /ISO = V _{DD}	2.8			V
		Annex J: I _{OH} = –9 mA, /ISO = 0	V _{DD} –0.4			V
V _{OL}	Low-level output voltage	I _{OL} = 4 mA, /ISO = V _{DD}			0.4	V
		Annex J: I _{OL} = 9 mA, /ISO = 0			0.4	V
I _{BH+}	Positive peak bus holder current	/ISO = V _{DD} , V _I = 0 V to V _{DD}	0.08		0.25	mA
I _{BH-}	Negative peak bus holder current	/ISO = V _{DD} , V _I = 0 V to V _{DD}	–0.25		–0.08	mA
I _I	Input current, pins LREQ, LPS, PD, TEST0, TEST1, PC0–PC2	/ISO = 0 V; V _{DD} = 3.6 V			5	μA
I _{OZ}	Off-state current, pins CTLn, Dn, C/LKON	V _O = V _{DD} or 0 V	–5		5	μA
I _{RST-UP}	Pullup current, /RESET input	V _I = 1.5 V, PD = 0	–80	–40	–20	μA
		V _I = 0 V, PD = 0	–90	–45	–22	μA
I _{RST-DN}	Pulldown current, /RESET input	V _I = V _{DD} , PD = V _{DD}	86	260	450	μA
V _{IT+}	Positive going threshold voltage, LREQ, CTL0, CTL1, D0–D7, C/LKON inputs ⁵	/ISO = 0 V	V _{DD} /2 + 0.3		V _{DD} /2 + 0.9	V
V _{IT-}	Negative going threshold voltage, LREQ, CTL0, CTL1, D0–D7, C/LKON inputs ⁵	/ISO = 0 V	V _{DD} /2 – 0.9		V _{DD} /2 – 0.3	V
V _{IT+}	Positive going threshold voltage, PD, LPS inputs	/ISO = 0 V. V _{LREF} = 0.42 x V _{DD}			V _{LREF} +1	V
V _{IT-}	Negative going threshold voltage, PD, LPS inputs	/ISO = 0 V. V _{LREF} = 0.42 x V _{DD}	V _{LREF} +0.2			V
V _O	TPBIAS output voltage	At rated I _O current	1.665		2.015	V

NOTES:

1. Worst case, all ports transmitting, 100% bandwidth at S400, V_{DD} = 3.6 V, T_A = 0°C: At T_A = 70°C, the maximum current is tbf mA.
2. All ports transmitting, 100% bandwidth at S400, V_{DD} = 3.3 V, T_A = 25°C
3. Receiving on port 0 and transmitting on port 1 and port 2. Full ISO payload of 84 μS, S400, data value of CCCCCCCh, V_{DD} = 3.3 V, T_A = 25°C
4. Receiving cycle starts on port 0 and transmitting cycle starts on port 1 and port 2, V_{DD} = 3.3 V, T_A = 25°C
5. C/LKON is only an input when /RESET = 0

3-port physical layer interface

PDI1394P21

13.0 THERMAL CHARACTERISTICS

SYMBOL	PARAMETER	TEST CONDITION	LIMITS			UNIT
			MIN	TYP	MAX	
R θ J α	Junction-to-free-air thermal resistance	Board mounted, no air flow		TBD		°C/W

14.0 AC CHARACTERISTICS

SYMBOL	PARAMETER	CONDITION	MIN	TYP	MAX	UNIT
	Transmit jitter	TPA, TPB			0.15	ns
	Transmit skew	Between TPA and TPB			0.10	ns
t _r	TPA, TPB differential output voltage rise time	10% to 90%; At 1394 connector	0.5		1.2	ns
t _f	TPA, TPB differential output voltage fall time	90% to 10%; At 1394 connector	0.5		1.2	ns
t _{su}	Setup time, CTL0, CTL1, D1–D7, LREQ to SYSCLK	50% to 50%; See Figure 2	5			ns
t _H	Hold time, CTL0, CTL1, D1–D7, LREQ after SYSCLK	50% to 50%; See Figure 2	0			ns
t _D	Delay time SYSCLK to CTL0, CTL1, D1–D7	50% to 50%; See Figure 3	0.5		11	ns

15.0 TIMING WAVEFORMS

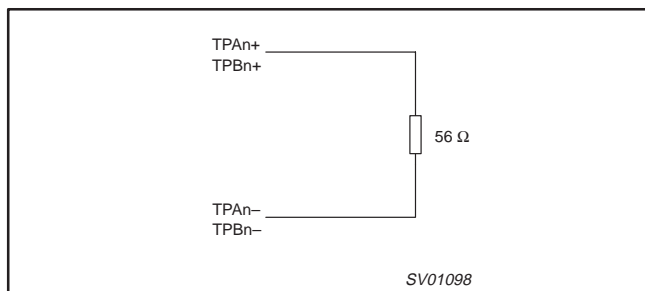

Figure 1. Test load diagram

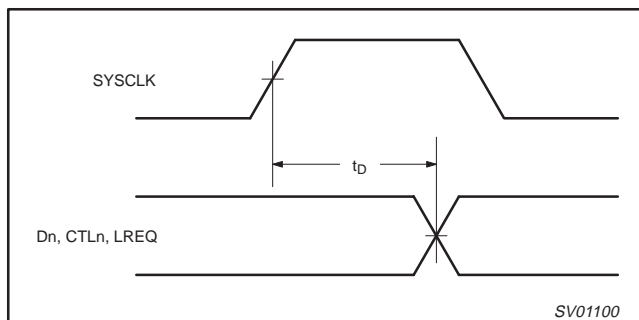

Figure 3. D_n, CTL_n, output delay relative to SYSCLK

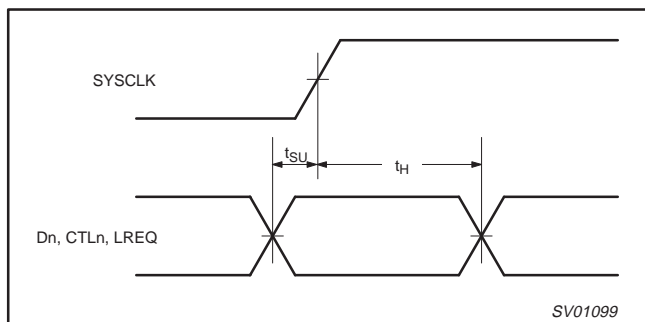

Figure 2. D_n, CTL_n, LREQ input setup and hold times

3-port physical layer interface

PDI1394P21

16.0 INTERNAL REGISTER CONFIGURATION

There are 16 accessible internal registers in the PDI1394P21. The configuration of the registers at addresses 0 through 7 (the base registers) is fixed, while the configuration of the registers at addresses 8h through Fh (the paged registers) is dependent upon which one of eight pages, numbered 0h through 7h, is currently selected. The selected page is set in base register 7h.

The configuration of the base registers is shown in Table 1, and corresponding field descriptions are given in Table 2. The base register field definitions are unaffected by the selected page number.

A reserved register or register field (marked as Reserved or Rsvd in the following register configuration tables) is read as 0, but is subject to future usage. All registers in address pages 2 through 6 are reserved.

Table 1. Base Register Configuration

ADDRESS	BIT POSITION							
	0	1	2	3	4	5	6	7
0000	Physical ID						R	CPS
0001	RHB	IBR	Gap_Count					
0010	Extended (111b)			Rsvd	Num_Ports (0011b)			
0011	PHY_Speed (010b)			Rsvd	Delay (0000b)			
0100	L	C	Jitter (000)			Pwr_Class		
0101	RPIE	ISBR	CTOI	CPSI	STOI	PEI	EAA	EMC
0110	Reserved							
0111	Page_Select			Rsvd	Port Select			

Table 2. Base Register Field Descriptions

FIELD	SIZE	TYPE	DESCRIPTION
Physical ID	6	Rd	This field contains the physical address ID of this node determined during self-ID. The physical-ID is invalid after a bus reset until self-ID has completed as indicated by an unsolicited register-0 status transfer.
R	1	Rd	Root. This bit indicates that this node is the root node. The R bit is reset to 0 by bus reset, and is set to 1 during tree-ID if this node becomes root.
CPS	1	Rd	Cable-power-status. This bit indicates the state of the CPS input terminal. The CPS terminal is normally tied to serial bus cable power through a 370 kΩ–410 kΩ resistor. A 0 in this bit indicates that the cable power voltage has dropped below its threshold for ensured reliable operation.
RHB	1	Rd/Wr	Root-holdoff bit. This bit instructs the PHY to attempt to become root after the next bus reset. The RHB bit is reset to 0 by a hardware reset, and is unaffected by a bus reset.
IBR	1	Rd/Wr	Initiate bus reset. This bit instructs the PHY to initiate a long (166 μs) bus reset at the next opportunity. Any receive or transmit operation in progress when this bit is set will complete before the bus reset is initiated. The IBR bit is reset to 0 after a hardware reset or a bus reset.
Gap_Count	6	Rd/Wr	Arbitration gap count. This value is used to set the subaction (fair) gap, arb-reset gap, and arb-delay times. The gap count can be set either by a write to the register, or by reception or transmission of a PHY_CONFIG packet. The gap count is reset to 3Fh by hardware reset or after two consecutive bus resets without an intervening write to the gap count register (either by a write to the PHY register or by a PHY_CONFIG packet).
Extended	3	Rd	Extended register definition. For the PDI1394P21, this field is 111b, indicating that the extended register set is implemented.
Num_Ports	4	Rd	Number of ports. This field indicates the number of ports implemented in the PHY. For the PDI1394P21 this field is 3.
PHY_Speed	3	Rd	PHY speed capability. For the PDI1394P21, this field is 010b, indicating S400 speed capability.
Delay	4	Rd	PHY repeater data delay. This field indicates the worst case repeater data delay for this PHY, expressed as 144+(delay × 20) ns. For the PDI1393P21, this field is 0.
L	1	Rd/Wr	Link active status. This bit indicates that this node's link is active. The logical AND of this bit and the LPS active status is replicated in the L field (bit 9) of the self-ID packet. This bit is set to 1 by a hardware reset and is unaffected by a bus reset.
C	1	Rd/Wr	Contender status. This bit indicates that this node is a contender for the bus or isochronous resource manager. This bit is replicated in the "c" field (bit 20) of the self-ID packet. This bit is set to the state specified by the C/LKON input terminal by a hardware reset and is unaffected by a bus reset.
Jitter	3	Rd	PHY repeater jitter. This field indicates the worst case difference between the fastest and slowest repeater data delay, expressed as (Jitter + 1) × 20 ns. For the PDI1394P21, this field is 0.

3-port physical layer interface

PDI1394P21

FIELD	SIZE	TYPE	DESCRIPTION
Pwr_Class	3	Rd/Wr	Node power class. This field indicates this node's power consumption and source characteristics and is replicated in the pwr field (bits 21–23) of the self-ID packet. This field is reset to the state specified by the PC0–PC2 input terminals upon hardware reset, and is unaffected by a bus reset. See Table 18.
RPIE	1	Rd/Wr	Resuming port interrupt enable. This bit, if set to 1, enables the port event interrupt (PEI) bit to be set whenever resume operations begin on any port. This bit is reset to 0 by hardware reset and is unaffected by bus reset.
ISBR	1	Rd/Wr	Initiate short arbitrated bus reset. This bit, if set to 1, instructs the PHY to initiate a short (1.3 μ s) arbitrated bus reset at the next opportunity. This bit is reset to 0 by a bus reset. NOTE: Legacy IEEE Std 1394–1995 compliant PHYs are not capable of performing short bus resets. Therefore, initiation of a short bus reset in a network that contains such a legacy device results in a long bus reset being performed.
CTOI	1	Rd/Wr	Configuration time-out interrupt. This bit is set to 1 when the arbitration controller times-out during tree-ID start, and may indicate that the bus is configured in a loop. This bit is reset to 0 by hardware reset, or by writing a 1 to this register bit. NOTE: If the network is configured in a loop, only those nodes which are part of the loop should generate a configuration time out interrupt. All other nodes should instead time out waiting for the tree-ID and/or self-ID process to complete and then generate a state time-out interrupt and bus-reset.
CPSI	1	Rd/Wr	Cable-power-status interrupt. This bit is set to 1 whenever the CPS input transitions from high to low indicating that cable power may be too low for reliable operation. This bit is reset to 0 by hardware reset, or by writing a 1 to this register bit.
STOI	1	Rd/Wr	State time-out interrupt. This bit indicates that a state time-out has occurred. This bit is reset to 0 by hardware reset, or by writing a 1 to this register bit.
PEI	1	Rd/Wr	Port event interrupt. This bit is set to 1 on any change in the connected, bias, disabled, or fault bits for any port for which the port interrupt enable (PIE) bit is set. Additionally, if the resuming port interrupt enable (RPIE) bit is set, the PEI bit is set to 1 at the start of resume operations on any port. This bit is reset to 0 by hardware reset, or by writing a 1 to this register bit.
EAA	1	Rd/Wr	Enable arbitration acceleration. This bit enables the PHY to perform the various arbitration acceleration enhancements defined in P1394a (ACK-accelerated arbitration, asynchronous fly-by concatenation, and isochronous fly-by concatenation). This bit is reset to 0 by hardware reset and is unaffected by bus reset. NOTE: The EAA bit should be set only if the attached LLC is P1394a compliant. If the LLC is not P1394a compliant, use of the arbitration acceleration enhancements can interfere with isochronous traffic by excessively delaying the transmission of cycle-start packets.
EMC	1	Rd/Wr	Enable multispeed concatenated packets. This bit enables the PHY to transmit concatenated packets of differing speeds in accordance with the protocols defined in P1394a. This bit is reset to 0 by hardware reset and is unaffected by bus reset. NOTE: The use of multispeed concatenation is completely compatible with networks containing legacy IEEE Std 1394–1995 PHYs. However, use of multispeed concatenation requires that the attached LLC be P1394a compliant.
Page_Select	3	Rd/Wr	Page_Select. This field selects the register page to use when accessing register addresses 8 through 15. This field is reset to 0 by a hardware reset and is unaffected by bus-reset.
Port_Select	4	Rd/Wr	Port_Select. This field selects the port when accessing per-port status or control (e.g., when one of the port status/control registers is accessed in page 0). Ports are numbered starting at 0. This field is reset to 0 by hardware reset and is unaffected by bus reset.

3-port physical layer interface

PDI1394P21

The Port Status page provides access to configuration and status information for each of the ports. The port is selected by writing 0 to the Page_Select field and the desired port number to the Port_Select field in base register 7. The configuration of the port status page registers is shown in Table 3 and corresponding field descriptions given in Table 4. If the selected port is unimplemented, all registers in the port status page are read as 0.

Table 3. Page 0 (Port Status) Register Configuration

ADDRESS	BIT POSITION							
	0	1	2	3	4	5	6	7
1000	AStat		BStat		Ch	Con	Bias	Dis
1001	Peer_Speed			PIE	Fault	Reserved		
1010	Reserved							
1011	Reserved							
1100	Reserved							
1101	Reserved							
1110	Reserved							
1111	Reserved							

Table 4. Page 0 (Port Status) Register Field Descriptions

FIELD	SIZE	TYPE	DESCRIPTION										
AStat	2	Rd	TPA line state. This field indicates the TPA line state of the selected port, encoded as follows: <table border="1" style="margin-left: 20px;"> <thead> <tr> <th>Code</th> <th>Arb Value</th> </tr> </thead> <tbody> <tr> <td>11</td> <td>Z</td> </tr> <tr> <td>01</td> <td>1</td> </tr> <tr> <td>10</td> <td>0</td> </tr> <tr> <td>00</td> <td>invalid</td> </tr> </tbody> </table>	Code	Arb Value	11	Z	01	1	10	0	00	invalid
Code	Arb Value												
11	Z												
01	1												
10	0												
00	invalid												
BStat	2	Rd	TPB line state. This field indicates the TPB line state of the selected port. This field has the same encoding as the ASTAT field.										
Ch	1	Rd	Child/parent status. A 1 indicates that the selected port is a child port. A 0 indicates that the selected port is the parent port. A disconnected, disabled, or suspended port is reported as a child port. The Ch bit is invalid after a bus-reset until tree-ID has completed.										
Con	1	Rd	Debounce port connection status. This bit indicates that the selected port is connected. The connection must be stable for the debounce time of 330ms–350ms for the Con bit to be set to 1. The Con bit is reset to 0 by hardware reset and is unaffected by bus reset. NOTE: The Con bit indicates that the port is physically connected to a peer PHY, but the port is not necessarily active.										
Bias	1	Rd	Debounce incoming cable bias status. A 1 indicates that the selected port is detecting incoming cable bias. The incoming cable bias must be stable for the debounce time of 41.6μs–52μs for the Bias bit to be set to 1.										
Dis	1	Rd/Wr	Port disabled control. If 1, the selected port is disabled. The Dis bit is reset to 0 by hardware reset (all ports are enabled for normal operation following hardware reset). The Dis bit is not affected by bus reset.										
Peer_Speed	3	Rd	Port peer speed. This field indicates the highest speed capability of the peer PHY connected to the selected port, encoded as follows: <table border="1" style="margin-left: 20px;"> <thead> <tr> <th>Code</th> <th>Peer Speed</th> </tr> </thead> <tbody> <tr> <td>000</td> <td>S100</td> </tr> <tr> <td>001</td> <td>S200</td> </tr> <tr> <td>010</td> <td>S400</td> </tr> <tr> <td>011–111</td> <td>invalid</td> </tr> </tbody> </table> The Peer_Speed field is invalid after a bus reset until self-ID has completed. NOTE: Peer speed codes higher than 010b (S400) are defined in P1394a. However, the PDI1394P21 is only capable of detecting peer speeds up to S400.	Code	Peer Speed	000	S100	001	S200	010	S400	011–111	invalid
Code	Peer Speed												
000	S100												
001	S200												
010	S400												
011–111	invalid												
PIE	1	Rd/Wr	Port event interrupt enable. When set to 1, a port event on the selected port will set the port event interrupt (PEI) bit and notify the link. this bit is reset to 0 by a hardware reset, and is unaffected by bus-reset.										
Fault	1	Rd/Wr	Fault. This bit indicates that a resume-fault or suspend-fault has occurred on the selected port, and that the port is in the suspended state. A resume-fault occurs when a resuming port fails to detect incoming cable bias from its attached peer. A suspend-fault occurs when a suspending port continues to detect incoming cable bias from its attached peer. Writing 1 to this bit clears the fault bit to 0. This bit is reset to 0 by hardware reset and is unaffected by bus reset.										

3-port physical layer interface

PDI1394P21

The Vendor Identification page is used to identify the vendor/manufacturer and compliance level. The page is selected by writing 1 to the Page_Select field in base register 7. The configuration of the Vendor Identification page is shown in Table 5, and corresponding field descriptions are given in Table 6.

Table 5. Page 1 (Vendor ID) Register Configuration

ADDRESS	BIT POSITION							
	0	1	2	3	4	5	6	7
1000	Compliance							
1001	Reserved							
1010	Vendor_ID[0]							
1011	Vendor_ID[1]							
1100	Vendor_ID[2]							
1101	Product_ID[0]							
1110	Product_ID[1]							
1111	Product_ID[2]							

Table 6. Page 1 (Vendor ID) Register Field Descriptions

FIELD	SIZE	TYPE	DESCRIPTION
Compliance	8	Rd	Compliance level. For the PDI1394P21, this field is 01h, indicating compliance with the P1394a specification.
Vendor_ID	24	Rd	Manufacturer's organizationally unique identifier (OUI). For the PDI1394P21, this field is 00_06_37h (Philips Semiconductors) (the MSB is at register address 1010b).
Product_ID	24	Rd	Product identifier. For the PDI1394P21, this field is 43_10_00h (the MSB is at register address 1101b).

3-port physical layer interface

PDI1394P21

17.0 APPLICATION INFORMATION

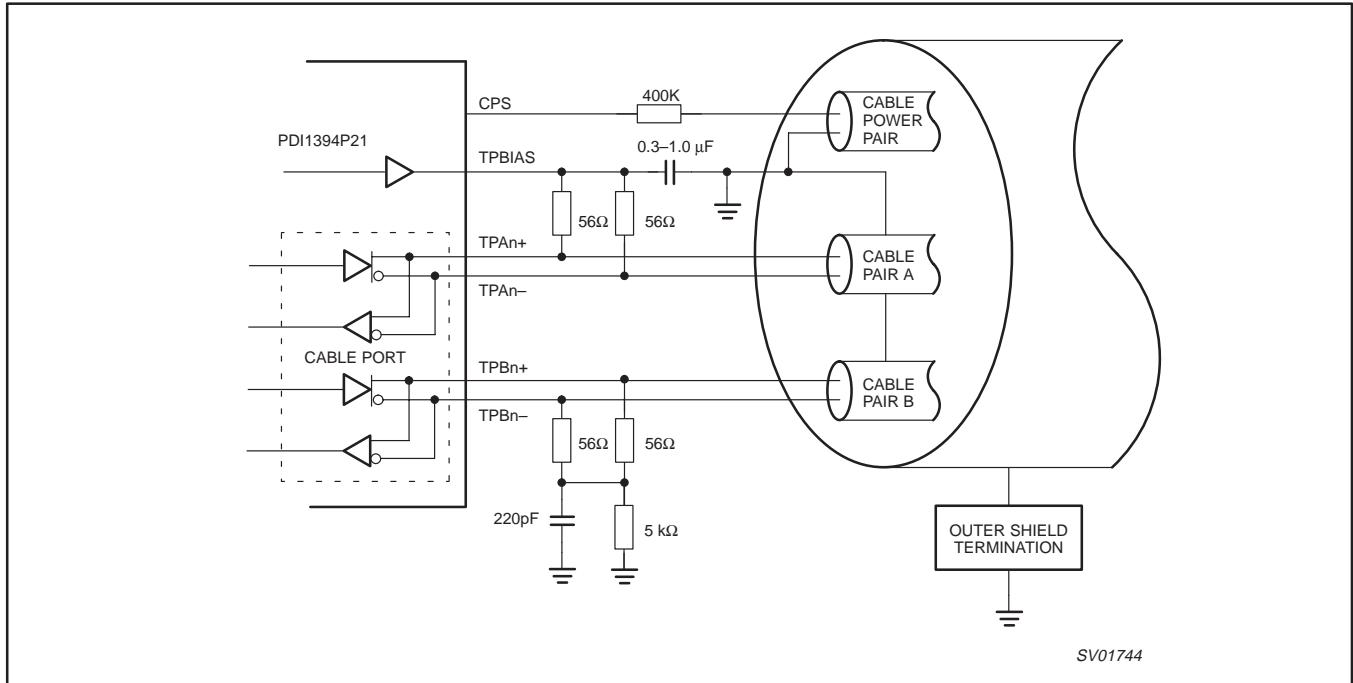

The IEEE Std 1394–1995 calls for a 250 pF capacitor, which is a non-standard component value. A 220 pF capacitor is recommended.
Figure 4. Twisted pair cable interface connections

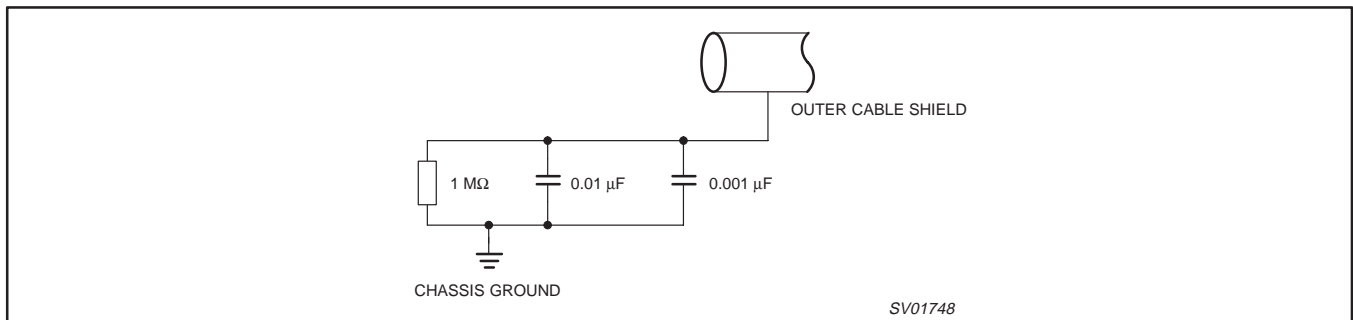
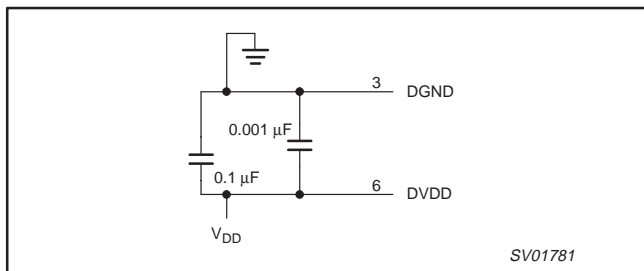

Figure 5. Typical outer shield termination



Use one of these networks per side for all digital power and ground pins and one per side for all analog power and ground pins. Place the network as close to the PHY as possible.

Figure 6. Power supply decoupling network

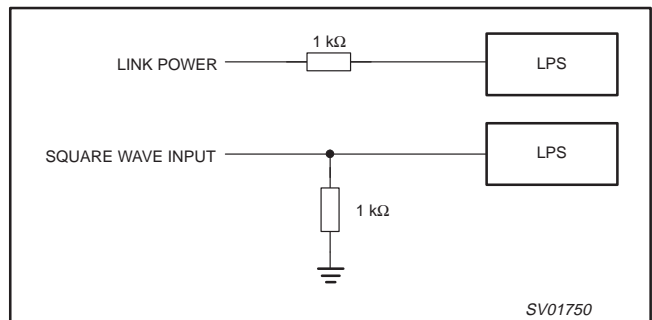
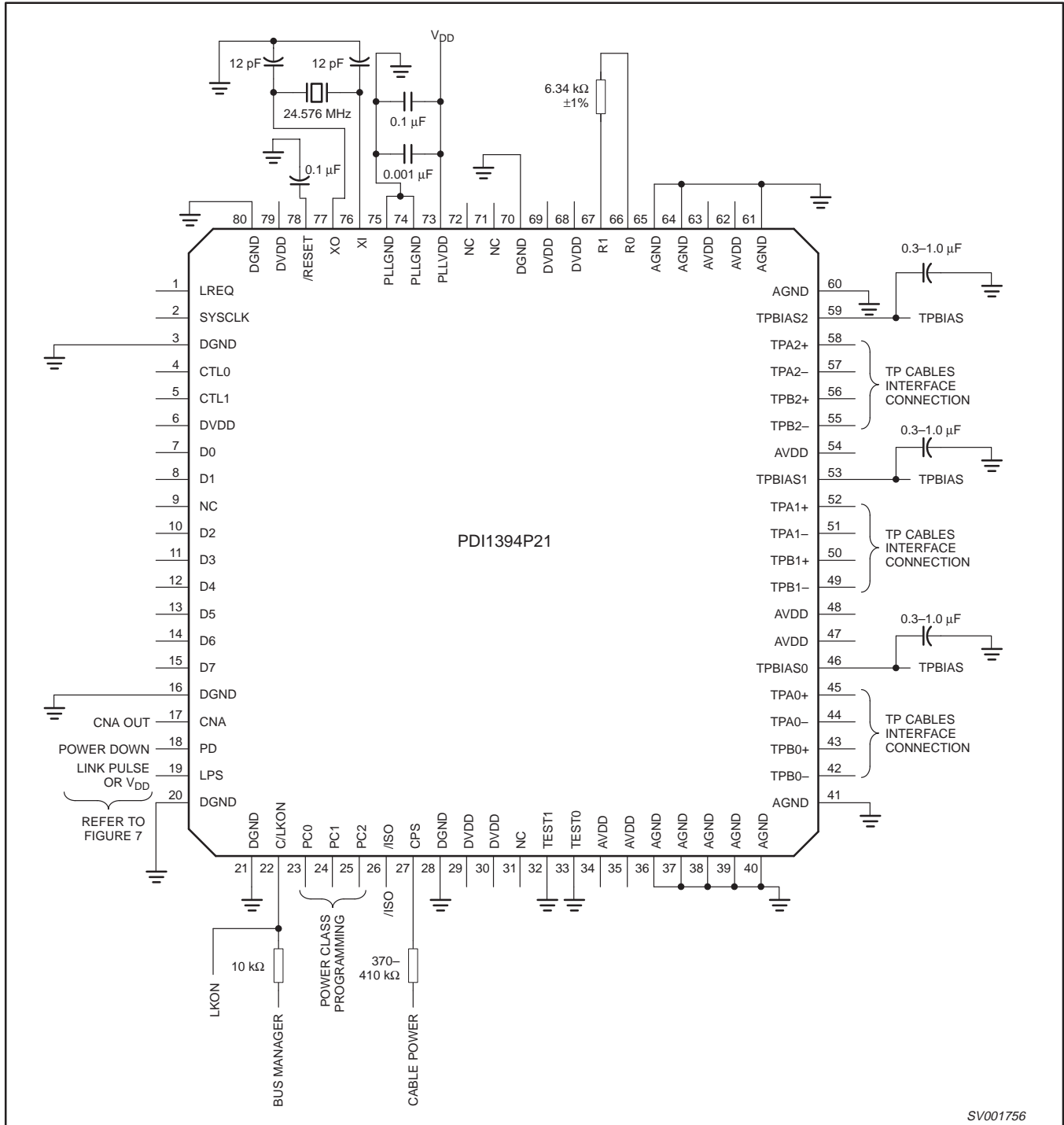

Figure 7. Non-isolated connection variations for LPS

3-port physical layer interface

PDI1394P21

17.1 External Component Connections



See Figure 6 for recommended power and ground connections.

Figure 8. External Component Connections

3-port physical layer interface

PDI1394P21

17.2 Using the PDI1394P21 with a non-P1394a link layer

The PDI1394P21 implements the PHY-LLC interface specified in the P1394a Supplement. This interface is based upon the interface described in informative Annex J of IEEE Std 1394-1995, which is the interface used in older PHY devices. The PHY-LLC interface specified in P1394a is completely compatible with the older Annex J interface.

The P1394a Supplement includes enhancements to the Annex J interface that must be comprehended when using the PDI1394P21 with a non-P1394a LLC device.

- A new LLC service request was added which allows the LLC to temporarily enable and disable asynchronous arbitration accelerations. If the LLC does not implement this new service request, the arbitration enhancements should not be enabled (see the EAA bit in PHY register 5).
- The capability to perform multispeed concatenation (the concatenation of packets of differing speeds) was added in order to improve bus efficiency (primarily during isochronous transmission). If the LLC does not support multispeed concatenation, multispeed concatenation should not be enabled in the PHY (see the EMC bit in PHY register 5).
- In order to accommodate the higher transmission speeds expected in future revisions of the standard, P1394a extended the speed code in bus requests from 2 bits to 3 bits, increasing the length of the bus request from 7 bits to 8 bits. The new speed codes were carefully selected so that new P1394a PHY and LLC devices would be compatible, for speeds from S100 to S400, with legacy PHY and LLC devices that use the 2-bit speed codes. The PDI1394P21 correctly interprets both 7-bit bus requests (with 2-bit speed code) and 8-bit bus requests (with 3-bit speed codes). Moreover, if a 7-bit bus request is immediately followed by another request (e.g., a register read or write request), the PDI1394P21 correctly interprets both requests. Although the PDI1394P21 correctly interprets 8-bit bus requests, a request with a speed code exceeding S400 results in the PDI1394P21 transmitting a null packet (data-prefix followed by data-end, with no data in the packet).

17.3 /Reset and Power Down

Forcing the /RESET pin low causes a Bus Reset condition on the active cable ports, and resets the internal logic to the Reset Start state. SYSCLK remains active. For power-up (and after Power Down is asserted) /RESET must be asserted low for a minimum of 2 ms from the time that the PHY power reaches the minimum required supply voltage. This is required to assure proper PLL operation before the PHY begins using the clock. An internal pull-up resistor is connected to V_{DD} , so only an external delay capacitor is required. When using a passive capacitor on the /RESET terminal to generate a power-on reset signal, the minimum value of 0.1 μF and also satisfies the following equation:

$$C_{\min} = 0.0077 \times T + 0.085$$

where C_{\min} is the minimum capacitance on the /RESET terminal in μF , and T is the V_{DD} ramp time, 10%–90%, in ms.

Additionally, an approximately 120 k Ω resistor should be connected in parallel with the reset capacitor from the /RESET terminal to GND to ensure that the capacitor is discharged when PHY power is removed. An alternative to the passive reset is to actively drive /RESET low for the minimum reset time following power on. This input is a standard logic buffer and may also be driven by an open drain logic output buffer.

The /RESET pin also has a n-channel pull-down transistor activated by the Power Down pin. For a reset during normal operation, a 10 μs low pulse on this pin will accomplish a full PHY reset. This pulse, as well as the 2 ms power up pulse, could be microprocessor controlled, in which case the external delay capacitor would not be needed. For more details on using single capacitor isolation with this pin, please refer to the Philips Isolation Application Note AN2452

The Power Down input powers down all device functions with the exception of the CNA circuit to conserve power in portable or battery-powered applications. It must be held high for at least 3.5 ms to assure a successful reset after power down. This pin is equipped with Bus Hold circuitry and supports an optional isolation barrier.

3-port physical layer interface

PDI1394P21

18.0 PRINCIPLES OF OPERATION

The PDI1394P21 is designed to operate with an LLC such as the Philips Semiconductors PDI1394L11 or PDI1394L21. The following paragraphs describe the operation of the PHY-LLC interface.

The interface to the LLC consists of the SYSCLK, CTL0–CTL1, D0–D7, LREQ, LPS, C/LKON, and /ISO terminals on the PDI1394P21 as shown in Figure 9.

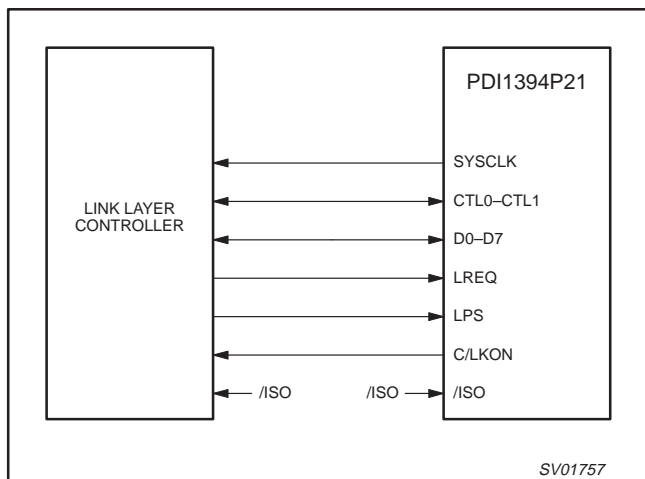

Figure 9. PHY-LLC interface

The SYSCLK terminal provides a 49.152 MHz interface clock. all control and data signals are synchronized to, and sampled on, the rising edge of SYSCLK.

The CTL0 and CTL1 terminals form a bidirectional control bus, which controls the flow of information and data between the PDI1394P21 and LLC.

The D0–D7 terminals form a bidirectional data bus, which is used to transfer status information, control information, or packet data between the devices. The PDI1394P21 supports S100, S200, and S400 data transfers over the D0–D7 data bus. In S100 operation only the D0 and D1 terminals are used; in S200 operation only the D0–D3 terminals are used; and in S400 operation all D0–D7

terminals are used for data transfer. When the PDI1394P21 is in control of the D0–D7 bus, unused Dn terminals are driven low during S100 and S200 operations. When the LLC is in control of the D0–D7 bus, unused Dn terminals are ignored by the PDI1394P21.

The LREQ terminal is controlled by the LLC to send serial service requests to the PHY in order to request access to the serial bus for packet transmission, read or write PHY registers, or control arbitration acceleration.

The LPS and C/LKON terminals are used for power management of the PHY and LLC. The LPS terminal indicates the power status of the LLC, and may be used to reset the PHY-LLC interface or to disable SYSCLK. The C/LKON terminal is used to send a wake-up notification to the LLC and to indicate an interrupt to the LLC when either LPS is inactive or the PHY register L bit is zero.

The /ISO terminal is used to enable the output differentiation logic on the CTL0–CTL1 and D0–D7 terminals. Output differentiation is required when an isolation barrier of the type described in Annex J of IEEE Std 1394-1995 is implemented between the PHY and LLC.

The PDI1394P21 normally controls the CTL0–CTL1 and D0–D7 bidirectional buses. The LLC is allowed to drive these buses only after the LLC has been granted permission to do so by the PHY.

There are four operations that may occur on the PHY-LLC interface: link service request, status transfer, data transmit, and data receive. The LLC issues a service request to read or write a PHY register, to request the PHY to gain control of the serial bus in order to transmit a packet, or to control arbitration acceleration.

The PHY may initiate a status transfer either autonomously or in response to a register read request from the LLC.

The PHY initiates a receive operation whenever a packet is received from the serial bus.

The PHY initiates a transmit operation after winning control of the serial-bus following a bus request by the LLC. The transmit operation is initiated when the PHY grants control of the interface to the LLC.

The encoding of the CTL0–CTL1 bus is shown in Table 7 and Table 8.

Table 7. CTL encoding when PHY has control of the bus

CTL0	CTL1	NAME	DESCRIPTION
0	0	Idle	No activity (this is the default mode)
0	1	Status	Status information is being sent from the PHY to the LLC
1	0	Receive	An incoming packet is being sent from the PHY to the LLC
1	1	Grant	The LLC has been given control of the bus to send an outgoing packet

Table 8. CTL encoding when LLC has control of the bus

CTL0	CTL1	NAME	DESCRIPTION
0	0	Idle	The LLC releases the bus (transmission has been completed)
0	1	Hold	The LLC is holding the bus while data is being prepared for transmission, or indicating that another packet is to be transmitted (concatenated) without arbitrating
1	0	Transmit	An outgoing packet is being sent from the LLC to the PHY
1	1	Reserved	None

3-port physical layer interface

PDI1394P21

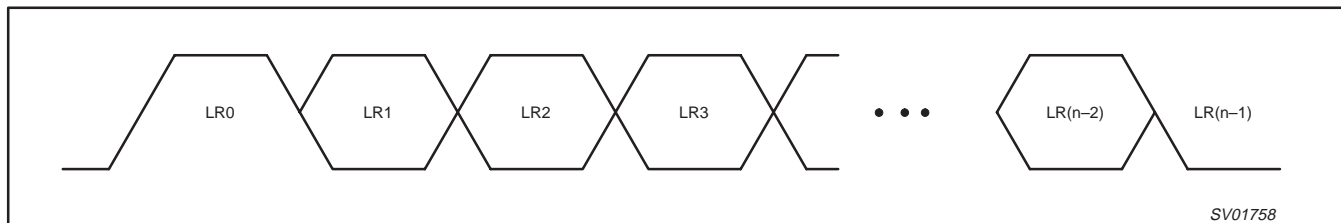

Figure 10. LREQ Request Stream

18.1 LLC service request

To request access to the bus, to read or write a PHY register, or to control arbitration acceleration, the LLC sends a serial bit stream on the LREQ terminal as shown in Figure 10.

The length of the stream will vary depending on the type of request as shown in Table 9.

Table 9. Request Stream Bit Length

REQUEST TYPE	NUMBER OF BITS
Bus request	7 or 8
Read register request	9
Write register request	17
Acceleration control request	6

Regardless of the type of request, a start bit of 1 is required at the beginning of the stream, and a stop bit of 0 is required at the end of the stream. The second through fourth bits of the request stream indicate the type of the request. In the descriptions below, bit 0 is the most significant, and is transmitted first in the request bit stream. The LREQ terminal is normally low.

Encoding for the request type is shown in Table 10.

Table 10. Request Type Encoding

LR1–LR3	NAME	DESCRIPTION
000	ImmReq	Immediate bus request. Upon detection of idle, the PHY takes control of the bus immediately without arbitration
001	IsoReq	Isochronous bus request. Upon detection of idle, the PHY arbitrates for the bus without waiting for a subaction gap.
010	PriReq	Priority bus request. The PHY arbitrates for the bus after a subaction gap, ignores the fair protocol.
011	FairReq	Fair bus request. The PHY arbitrates for the bus after a subaction gap, follows the fair protocol
100	RdReg	The PHY returns the specified register contents through a status transfer.
101	WrReg	Write to the specified register.
110	AccelCtl	Enable or disable asynchronous arbitration acceleration.
111	Reserved	Reserved.

For a bus request the length of the LREQ bit stream is 7 or 8 bits, as shown in Table 11.

Table 11. Bus Request

BIT(S)	NAME	DESCRIPTION
0	Start Bit	Indicates the beginning of the transfer (always 1).
1–3	Request Type	Indicates the type of bus request. See Table 10.
4–6	Request Speed	Indicates the speed at which the PHY will send the data for this request. See Table 12 for the encoding of this field.
7	Stop Bit	Indicates the end of the transfer (always 0). If bit 6 is 0, this bit may be omitted.

The 3-bit request speed field used in bus requests is shown in Table 12.

Table 12. Bus Request Speed Encoding

LR4–LR6	DATA RATE
000	S100
010	S200
100	S400
All others	Invalid

NOTE:

The PDI1394P21 will accept a bus request with an invalid speed code and process the bus request normally. However, during packet transmission for such a request, the PDI1394P21 will ignore any data presented by the LLC and will transmit a null packet.

For a read register request, the length of the LREQ bit stream is 9 bits as shown in Table 13.

Table 13. Read Register Request

BIT(S)	NAME	DESCRIPTION
0	Start Bit	Indicates the beginning of the transfer (always 1).
1–3	Request Type	A 100 indicating this is a read register request.
4–7	Address	Identifies the address of the PHY register to be read.
8	Stop Bit	Indicates the end of the transfer (always 0).

3-port physical layer interface

PDI1394P21

For a write register request, the length of the LREQ bit stream is 17 bits as shown in Table 14.

Table 14. Write Register Request

BIT(S)	NAME	DESCRIPTION
0	Start Bit	Indicates the beginning of the transfer (always 1).
1–3	Request Type	A 101 indicating that this is a write register request.
4–7	Address	Identifies the address of the PHY register to be written to.
8–15	Data	Gives the data that is to be written to the specified register address.
16	Stop Bit	Indicates the end of the transfer (always 0).

For an acceleration control request, the length of the LREQ data stream is 6 bits as shown in Table 15.

Table 15. Acceleration Control Request

BIT(S)	NAME	DESCRIPTION
0	Start Bit	Indicates the beginning of the transfer (always 1).
1–3	Request Type	A 110 indicating this is an acceleration control request.
4	Control	Asynchronous period arbitration acceleration is enabled if 1, and disabled if 0.
5	Stop Bit	Indicates the end of the transfer (always 0).

For fair or priority access, the LLC sends the bus request (FairReq or PriReq) at least one clock after the PHY-LLC interface becomes idle. If the CTL terminals are asserted to the receive state (10b) by the PHY, then any pending fair or priority request is lost (cleared). Additionally, the PHY ignores any fair or priority requests if the Receive state is asserted while the LLC is sending the request. The LLC may then reissue the request one clock after the next interface idle.

The cycle master node uses priority bus request (PriReq) to send a cycle start packet. After receiving or transmitting a cycle start message, the LLC can issue an isochronous bus request (IsoReq). The PHY will clear an isochronous request only when the bus has been won.

To send an acknowledge packet, the link must issue an immediate bus request (ImmReq) during the reception of the packet addressed to it. This is required in order to minimize the idle gap between the

end of the received packet and the start of the transmitted acknowledge packet. As soon as the receive packet ends, the PHY immediately grants control of the bus to the LLC. The LLC sends an acknowledgment to the sender unless the header CRC of the received packet is corrupted. In this case, the LLC does not transmit an acknowledge, but instead cancels the transmit operation and releases the interface immediately; the LLC must not use this grant to send another type of packet. After the interface is released, the LLC may proceed with another request.

The LLC may request only one bus request at a time. Once the LLC issues any request for bus access (ImmReq, IsoReq, FairReq, or PriReq), it cannot issue another request until the PHY indicates that the bus request was “lost” (bus arbitration lost and another packet received), or “won” (bus arbitration won and the LLC granted control). The PHY ignores new bus requests while a previous bus request is pending. All bus requests are cleared upon a bus reset.

For write register requests, the PHY loads the specified data into the addressed register as soon as the request transfer is complete. For read register requests, the PHY returns the contents of the addressed register to the LLC at the next opportunity through a status transfer. If a received packet interrupts the status transfer, then the PHY continues to attempt the transfer of the requested register until it is successful. A write or read register request may be made at any time, including while a bus request is pending. Once a read register request is made, the PHY ignores further read register requests until the register contents are successfully transferred to the LLC. A bus reset does not clear a pending read register request.

The PDI1394P21 includes several arbitration acceleration enhancements which allow the PHY to improve bus performance and throughput by reducing the number and length of inter-packet gaps. These enhancements include autonomous (fly-by) isochronous packet concatenation, autonomous fair and priority packet concatenation onto acknowledge packets, and accelerated fair and priority request arbitration following acknowledge packets. Then enhancements are enabled when the EAA bit in PHY register 5 is set.

The arbitration acceleration enhancements may interfere with the ability of the cycle master node to transmit the cycle start packet under certain circumstances. The acceleration control request is therefore provided to allow the LLC to temporarily enable or disable the arbitration acceleration enhancements of the PDI1394P21 during the asynchronous period. The LLC typically disables the enhancements when its internal cycle counter rolls over indicating that a cycle start packet is imminent, and then re-enables the enhancements when it receives a cycle start packet. The acceleration control request may be made at any time, however, and is immediately serviced by the PHY. Additionally, a bus reset or isochronous bus request will cause the enhancements to be re-enabled, if the EAA bit is set.

3-port physical layer interface

PDI1394P21

18.2 Status transfer

A status transfer is initiated by the PHY when there is status information to be transferred to the LLC. The PHY waits until the interface is idle before starting the transfer. The transfer is initiated by the PHY asserting Status (01b) on the CTL terminals, along with the first two bits of status information on the D[0:1] terminals. The PHY maintains CTL = Status for the duration of the status transfer. The PHY may prematurely end a status transfer by asserting something other than Status on the CTL terminals. This occurs if a packet is received before the status transfer completes. The PHY continues to attempt to complete the transfer until all status information has been successfully transmitted. There is at least one idle cycle between consecutive status transfers.

The PHY normally sends just the first four bits of status to the LLC. These bits are status flags that are needed by the LLC state machines. The PHY sends an entire 16-bit status packet to the LLC after a read register request, or when the PHY has pertinent information to send to the LLC or transaction layers. The only defined condition where the PHY automatically sends a register to the LLC is after self-ID, where the PHY sends the physical-ID register that contains the new node address. All status transfers are either 4 or 16 bits unless interrupted by a received packet. The status flags are considered to have been successfully transmitted to the LLC immediately upon being sent, even if a received packet

subsequently interrupts the status transfer. Register contents are considered to have been successfully transmitted only when all 8 bits of the register have been sent. A status transfer is retried after being interrupted only if any status flags remain to be sent, or if a register transfer has not yet completed.

The definition of the bits in the status transfer is shown in Table 16, and the timing is shown in Figure 11.

The sequence of events for a status transfer is as follows:

- Status transfer initiated. the PHY indicates a status transfer by asserting status on the CTL lines along with the status data on the D0 and D1 lines (only 2 bits of status are transferred per cycle). Normally (unless interrupted by a receive operation), a status transfer will be either 2 or 8 cycles long. A 2-cycle (4 bit) transfer occurs when only status information is to be sent. An 8-cycle (16 bit) transfer occurs when register data is to be sent in addition to any status information.
- Status transfer terminated. The PHY normally terminates a status transfer by asserting idle on the CTL lines. If a bus reset is pending, the PHY may also assert Grant on the CTL line immediately following a complete status transfer.

Table 16. Status Bits

BIT(S)	NAME	DESCRIPTION
0	Arbitration Reset Gap	Indicates that the PHY has detected that the bus has been idle for an arbitration reset gap time (as defined in the IEEE 1394–1995 standard). This bit is used by the LLC in the busy/retry state machine.
1	Subaction gap	Indicates that the PHY has detected that the bus has been idle for a subaction gap time (as defined in the IEEE 1394–1995 standard). This bit is used by the LLC to detect the completion of an isochronous cycle.
2	Bus reset	Indicates that the PHY has entered the bus reset state.
3	Interrupt	Indicates that a PHY interrupt event has occurred. An interrupt event may be a configuration time-out, a cable-power voltage falling too low, a state time-out, or a port status change.
4–7	Address	This field holds the address of the PHY register whose contents are being transferred to the LLC.
8–15	Data	This field holds the register contents.

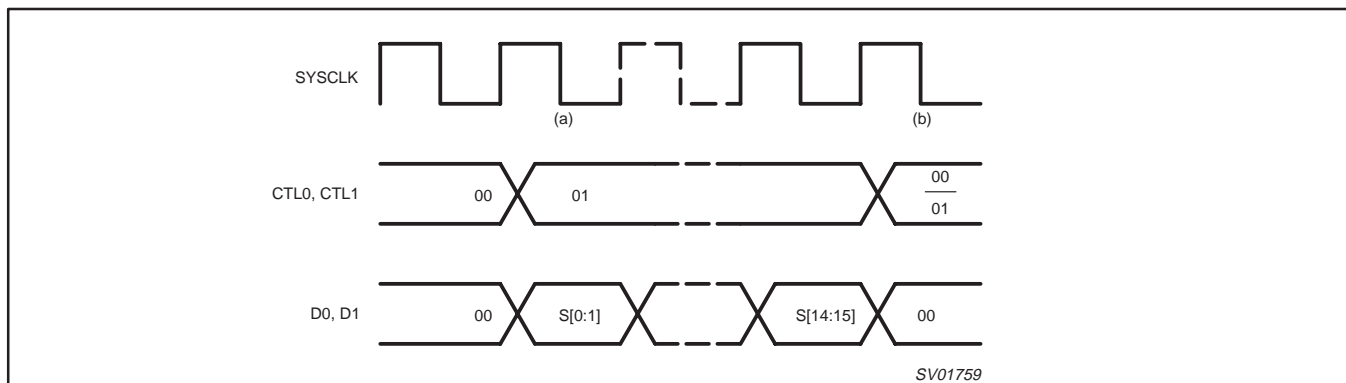

Figure 11. Status Transfer Timing

3-port physical layer interface

PDI1394P21

18.3 Receive

Whenever the PHY detects the data-prefix state on the serial bus, it initiates a receive operation by asserting Receive on the CTL terminals and a logic 1 on each of the D terminals (“data-on” indication). The PHY indicates the start of a packet by placing the speed code (encoded as shown in Table 17) on the D terminals, followed by packet data. The PHY holds the CTL terminals in the Receive state until the last symbol of the packet has been transferred. The PHY indicates the end of packet data by asserting Idle on the CTL terminals. All received packets are transferred to the LLC. Note that the speed code is part of the PHY-LLC protocol and is not included in the calculation of CRC or any other data protection mechanisms.

Table 17. Speed Code for the Receiver

D0–D7	DATA RATE
0000 0000	S100
0100 0000	S200
0101 0000	S400
1111 1111	“data-on” indication

It is possible for the PHY to receive a null packet, which consists of the data-prefix state on the serial bus followed by the data-end state, without any packet data. A null packet is transmitted whenever the packet speed exceeds the capability of the receiving PHY, or whenever the LLC immediately releases the bus without transmitting any data. In this case, the PHY will assert Receive on the CTL terminals with the “data-on” indication (all 1’s) on the D terminals, followed by Idle on the CTL terminals, without any speed code or data being transferred. In all cases, in normal operation, the

PDI1394P21 sends at least one “data-on” indication before sending the speed code or terminating the receive operation.

The PDI1394P21 also transfers its own self-ID packet, transmitted during the self-ID phase of bus initialization to the LLC. This packet is transferred to the LLC just as any other received self-ID packet.

The sequence of events for a normal packet reception is as follows:

- Receive operation initiated. The PHY indicates a receive operation by asserting Receive on the CTL lines. Normally, the interface is idle when receive is asserted. However, the receive operation may interrupt a status transfer operation that is in progress so that the CTL lines may change from status to receive without an intervening idle.
- Data-on indication. The PHY may assert the data-on indication code on the D lines for one or more cycles preceding the speed code.
- Speed code. The PHY indicates the speed of the received packet by asserting a speed code on the D lines for one cycle immediately preceding packet data. The link decodes the speed code on the first Receive cycle for which the D lines are not the data-on code. If the speed code is invalid, or indicates a speed higher than that which the link is capable of handling, the link should ignore the subsequent data.
- Receive data. Following the data-on indication (if any) and the speed code, the PHY asserts packet data on the D lines with receive on the CTL lines for the remainder of the receive operation.
- Receive operation terminated. The PHY terminates the receive operation by asserting the idle on the CTL lines. The PHY asserts at least one cycle of idle following a receive operation.

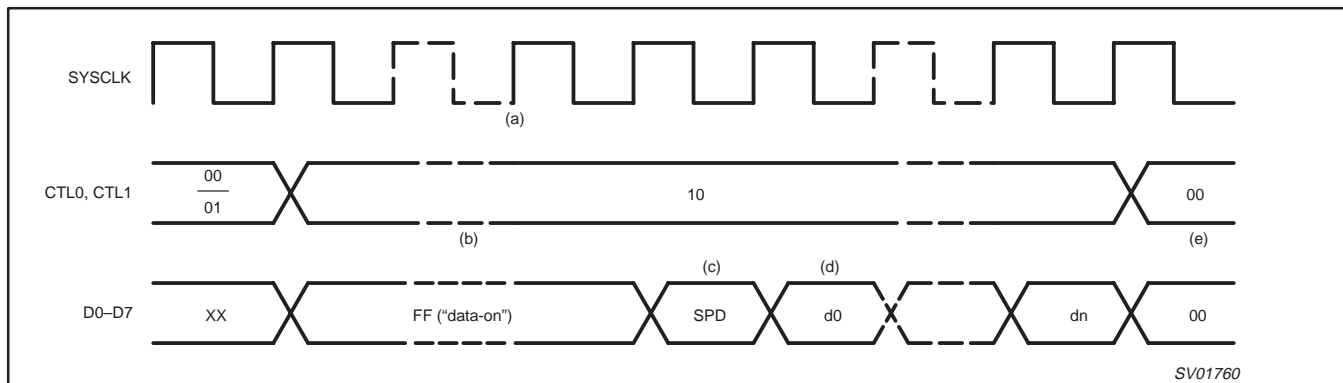

NOTE: SPD = Speed code; see Table 17; d0–dn = Packet data.

Figure 12. Normal Packet Reception Timing

3-port physical layer interface

PDI1394P21

The sequence of events for a null packet reception is as follows:

- Receive operation initiated. The PHY indicates a receive operation by asserting receive on the CTL lines. Normally, the interface is idle when receive is asserted. However, the receive operation may interrupt a status transfer operation that is in progress so that the CTL lines may change from status to receive without an intervening idle.
- Data-on indication. The PHY asserts the data-on indication code on the D lines for one or more cycles.
- Receive operation terminated. The PHY terminates the receive operation by asserting Idle on the CTL lines. The PHY shall assert at least one cycle of Idle following a receive operation.

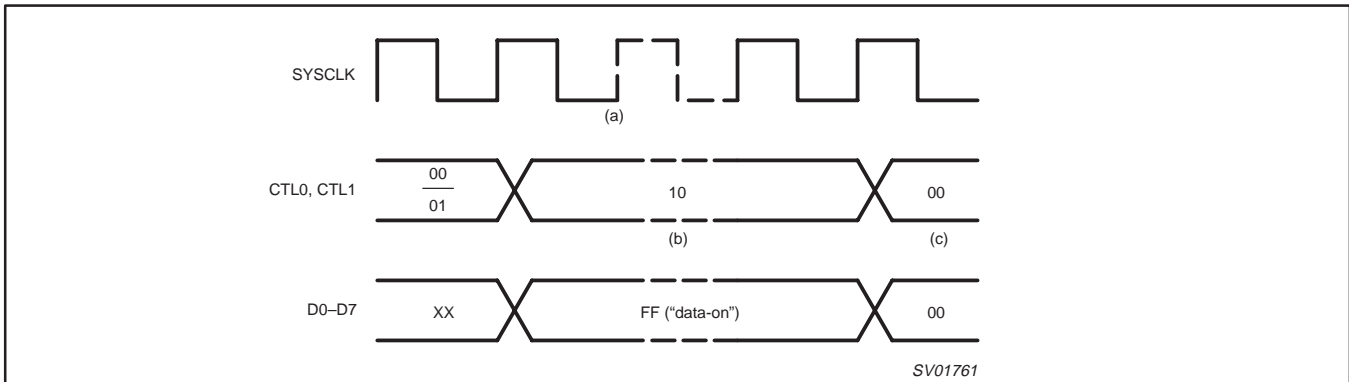

Figure 13. Null Packet Reception Timing

3-port physical layer interface

PDI1394P21

18.4 Transmit

When the LLC issues a bus request through the LREQ terminal, the PHY arbitrates to gain control of the bus. If the PHY wins arbitration for the serial bus, the PHY-LLC interface bus is granted to the link by asserting the Grant state (11b) on the CTL terminals for one SYSCLK cycle, followed by Idle for one clock cycle. The LLC then takes control of the bus by asserting either Idle (00b), Hold (01b), or Transmit (10b) on the CTL terminals. Unless the LLC is immediately releasing the interface, the link may assert the Idle state for at most one clock before it must assert either Hold or Transmit on the CTL terminals. The Hold state is used by the LLC to retain control of the bus while it prepares data for transmission. The LLC may assert Hold for zero or more clock cycles (i.e., the LLC need not assert Hold before Transmit). The PHY asserts data-prefix on the serial bus during this time.

When the LLC is ready to send data, the LLC asserts Transmit on the CTL terminals as well as sending the first bits of packet data on the D lines. The Transmit state is held on the CTL terminals until the last bits of data have been sent. The LLC then asserts either Hold or Idle on the CTL terminals for one clock cycle and then asserts Idle for one additional cycle before releasing the interface bus and putting the CTL and D terminals in a high-impedance state. The PHY then regains control of the interface bus.

The Hold state asserted at the end of packet transmission indicates to the PHY that the LLC requests to send another packet (concatenated packet) without releasing the serial bus. The PHY responds to this concatenation request by waiting the required minimum packet separation time and then asserting Grant as before. This function may be used to send a unified response after sending an acknowledge, or to send consecutive isochronous packets during a single isochronous period. Unless multi-speed concatenation is enabled, all packets transmitted during a single bus ownership must be of the same speed (since the speed of the packet is set before the first packet). If multi-speed concatenation is enabled (when the EMSC bit of PHY register 5 is set), the LLC must specify the speed code of the next concatenated packet on the D terminals when it asserts Hold on the CTL terminals at the end of a packet. The encoding for this speed code is the same as the speed code that precedes received packet data as given in Table 17.

After sending the last packet for the current bus ownership, the LLC releases the bus by asserting Idle on the CTL terminals for two clock cycles. The PHY begins asserting Idle on the CTL terminals one clock after sampling Idle from the link. Note that whenever the D and

CTL terminals change direction between the PHY and the LLC, there is an extra clock period allowed so that both sides of the interface can operate on registered versions of the interface signals.

The sequence of events for a normal packet transmission is as follows:

- Transmit operation initiated. The PHY asserts grant on the CTL lines followed by Idle to hand over control of the interface to the link so that the link may transmit a packet. The PHY releases control of the interface (i.e., it 3-States the CTL and D outputs) following the idle cycle.
- Optional idle cycle. The link may assert at most one idle cycle preceding assertion of either hold or transmit. This idle cycle is optional; the link is not required to assert Idle preceding either hold or transmit.
- Optional hold cycles. The link may assert hold for up to 47 cycles preceding assertion of transmit. These hold cycle(s) are optional; the link is not required to assert hold preceding transmit.
- Transmit data. When data is ready to be transmitted, the link asserts transmit on the CTL lines along with the data on the D lines.
- Transmit operation terminated. The transmit operation is terminated by the link asserting hold or idle on the CTL lines the link asserts hold to indicate that the PHY is to retain control of the serial bus in order to transmit a concatenated packet. the link asserts idle to indicate that packet transmission is complete and the PHY may release the serial bus. The link then asserts Idle for one more cycle following this cycle of hold or idle before releasing the interface and returning control the the PHY.
- Concatenated packet speed-code. If multi-speed concatenation is enabled in the PHY, the link shall assert a speed-code on the D lines when it asserts Hold to terminate packet transmission. This speed-code indicates the transmission speed for the concatenated packet that is to follow. The encoding for this concatenated packet speed-code is the same as the encoding for the received packet speed-code (see Table 17). the link may not concatenate an S100 packet onto any higher speed packet.
- After regaining control of the interface, the PHY shall assert at least one cycle of idle before any subsequent status transfer, receive operation, or transmit operation.

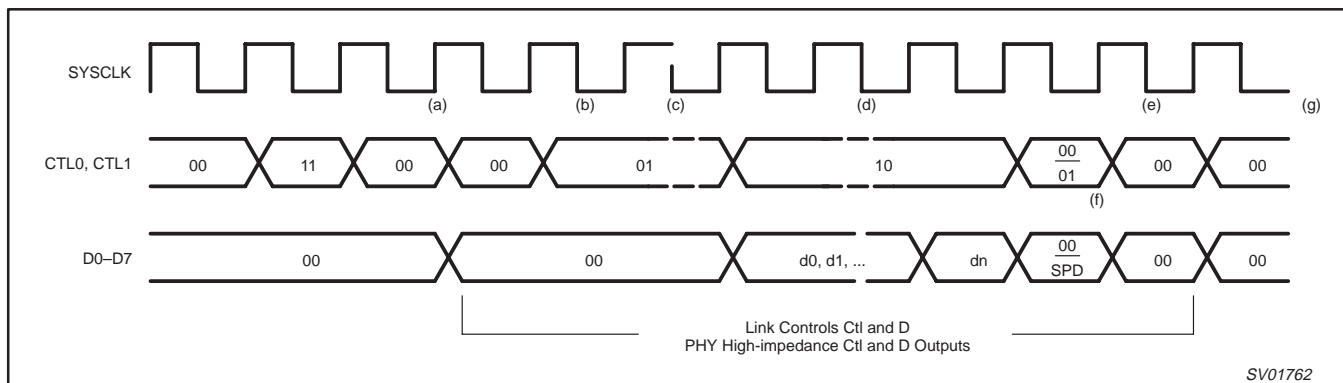

NOTE: SPD = Speed code; see Table 17; d0–dn = Packet data.

Figure 14. Normal Packet Transmission Timing

3-port physical layer interface

PDI1394P21

The sequence of events for a cancelled/null packet transmission is as follows:

- Transmit operation initiated. PHY asserts grant on the CTL lines followed by idle to hand over control of the interface to the link.
- Optional Idle cycle. The link may assert at most one idle cycle preceding assertion of hold. This idle cycle is optional; the link is not required to assert idle preceding Hold.
- Optional Hold cycles. The link may assert Hold for up to 47 cycles preceding assertion of idle. These hold cycle(s) are optional; the link is not required to assert hold preceding Idle.
- Null transmit termination. The null transmit operation is terminated by the link asserting two cycles of idle on the CTL lines and then releasing the interface and returning control to the PHY. Note that the link may assert Idle for a total of 3 consecutive cycles if it asserts the optional first idle cycle but does not assert hold. It is recommended that the link assert 3 cycles of Idle to cancel a packet transmission if no hold cycles are asserted. This ensures that either the link or PHY controls the interface in all cycles.
- After regaining control of the interface, the PHY shall assert at least one cycle of Idle before any subsequent status transfer, receive operation, or transmit operation.

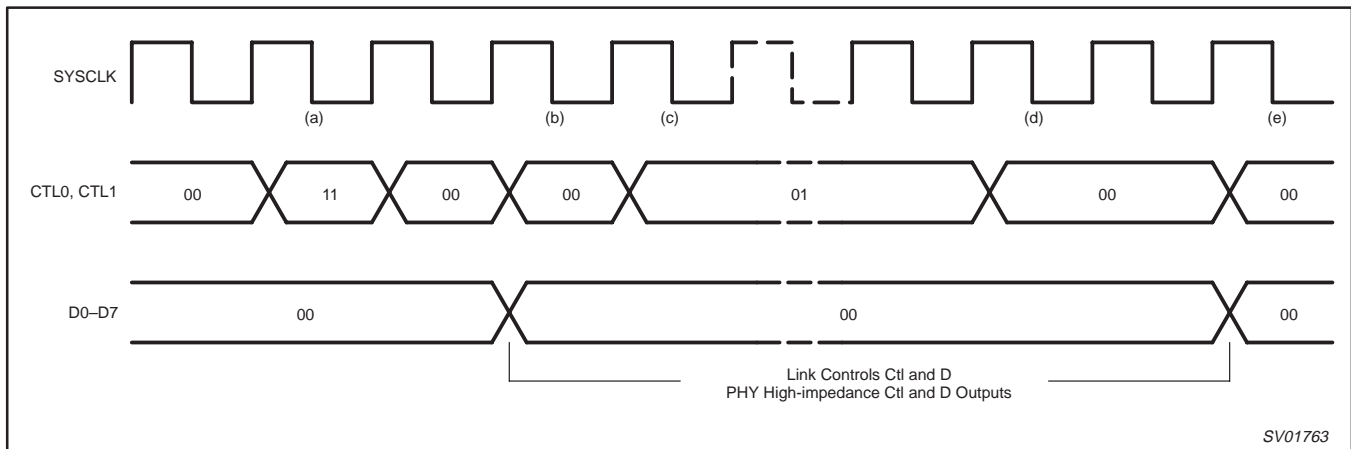

Figure 15. Cancelled/Null Packet Transmission

19.0 POWER-CLASS PROGRAMMING

The PC0–PC2 terminals are programmed to set the default value of the power-class indicated in the pwr field (bits 21–23) of the transmitted self-ID packet. Descriptions of the various power-classes are given in Table 18. The default power-class value is loaded following a hardware reset, but is overridden by any value subsequently loaded into the Pwr_Class field in register 4.

Table 18. Power Class Descriptions

PC0-PC2	DESCRIPTION
000	Node does not need power and does not repeat power.
001	Node is self powered, and provides a minimum of 15 W to the bus.
010	Node is self powered, and provides a minimum of 30 W to the bus.
011	Node is self powered, and provides a minimum of 45 W to the bus.
100	Node may be powered from the bus and is using up to 3 W.
101	Node is powered from the bus and uses up to 3 W. No additional power is needed to enable the link.
110	Node is powered from the bus and uses up to 3 W. An additional 3 W is needed to enable the link.
111	Node is powered from the bus and uses up to 3 W. An additional 7 W is needed to enable the link.

3-port physical layer interface

PDI1394P21

LQFP80: plastic low profile quad flat package; 80 leads; body 12 x 12 x 1.4 mm

SOT315-1

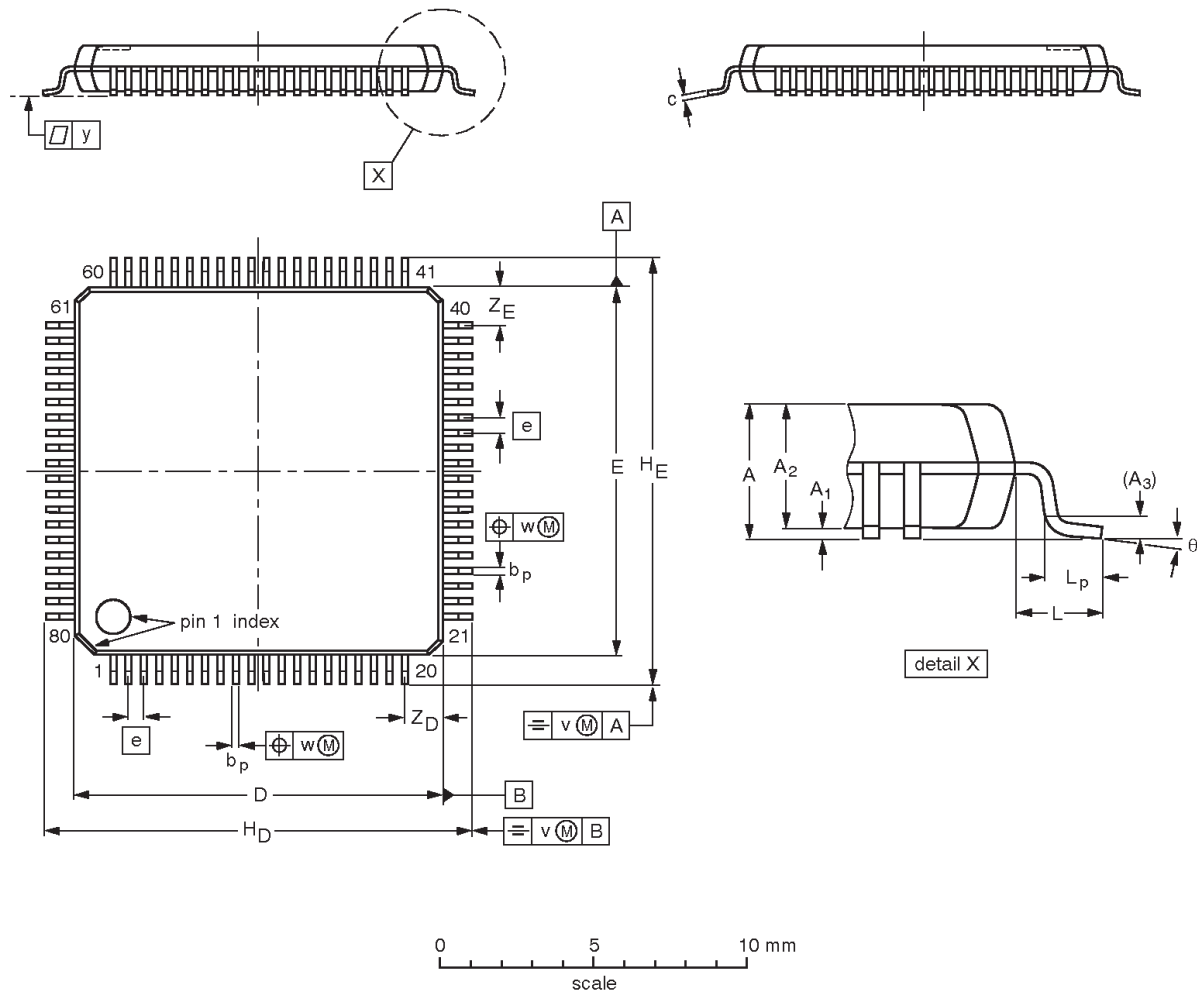

DIMENSIONS (mm are the original dimensions)

UNIT	A max.	A ₁	A ₂	A ₃	b _p	c	D ⁽¹⁾	E ⁽¹⁾	e	H _D	H _E	L	L _p	v	w	y	Z _D ⁽¹⁾	Z _E ⁽¹⁾	θ
mm	1.6	0.16 0.04	1.5 1.3	0.25	0.27 0.13	0.18 0.12	12.1 11.9	12.1 11.9	0.5	14.15 13.85	14.15 13.85	1.0	0.75 0.30	0.2	0.15	0.1	1.45 1.05	1.45 1.05	7° 0°

Note

1. Plastic or metal protrusions of 0.25 mm maximum per side are not included.

OUTLINE VERSION	REFERENCES				EUROPEAN PROJECTION	ISSUE DATE
	IEC	JEDEC	EIAJ			
SOT315-1						95-12-19 97-07-15

3-port physical layer interface

PDI1394P21

Data sheet status

Data sheet status	Product status	Definition [1]
Objective specification	Development	This data sheet contains the design target or goal specifications for product development. Specification may change in any manner without notice.
Preliminary specification	Qualification	This data sheet contains preliminary data, and supplementary data will be published at a later date. Philips Semiconductors reserves the right to make changes at any time without notice in order to improve design and supply the best possible product.
Product specification	Production	This data sheet contains final specifications. Philips Semiconductors reserves the right to make changes at any time without notice in order to improve design and supply the best possible product.

[1] Please consult the most recently issued datasheet before initiating or completing a design.

Definitions

Short-form specification — The data in a short-form specification is extracted from a full data sheet with the same type number and title. For detailed information see the relevant data sheet or data handbook.

Limiting values definition — Limiting values given are in accordance with the Absolute Maximum Rating System (IEC 134). Stress above one or more of the limiting values may cause permanent damage to the device. These are stress ratings only and operation of the device at these or at any other conditions above those given in the Characteristics sections of the specification is not implied. Exposure to limiting values for extended periods may affect device reliability.

Application information — Applications that are described herein for any of these products are for illustrative purposes only. Philips Semiconductors make no representation or warranty that such applications will be suitable for the specified use without further testing or modification.

Disclaimers

Life support — These products are not designed for use in life support appliances, devices or systems where malfunction of these products can reasonably be expected to result in personal injury. Philips Semiconductors customers using or selling these products for use in such applications do so at their own risk and agree to fully indemnify Philips Semiconductors for any damages resulting from such application.

Right to make changes — Philips Semiconductors reserves the right to make changes, without notice, in the products, including circuits, standard cells, and/or software, described or contained herein in order to improve design and/or performance. Philips Semiconductors assumes no responsibility or liability for the use of any of these products, conveys no license or title under any patent, copyright, or mask work right to these products, and makes no representations or warranties that these products are free from patent, copyright, or mask work right infringement, unless otherwise specified.

Philips Semiconductors
811 East Arques Avenue
P.O. Box 3409
Sunnyvale, California 94088-3409
Telephone 800-234-7381

© Copyright Philips Electronics North America Corporation 1999
All rights reserved. Printed in U.S.A.

Date of release: 08-99

Document order number:

9397-750-06384

Let's make things better.