



MBR20100C

DIODE

SCHOTTKY BARRIER RECTIFIER

■ FEATURES

- * 20 amps total (10 amps per diode leg)
- * Guard ring for transient protection
- * Low forward voltage drop
- * High surge capability
- * Low power loss/High efficiency

■ SYMBOL

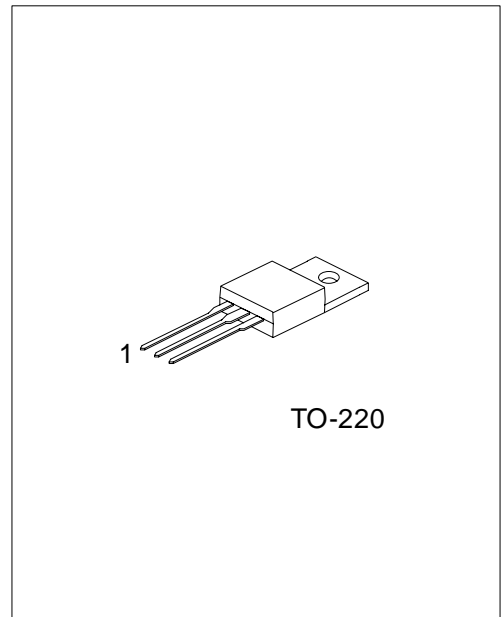
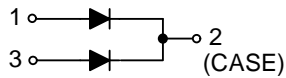

*Pb-free plating product number: MBR20100CL

■ ORDERING INFORMATION

Order Number		Package	Pin Assignment			Packing
Normal	Lead Free Plating		1	2	3	
MBR20100C-TA3-T	MBR20100CL-TA3-T	TO-220	A	K	A	Tube

Note: Pin Assignment: A: Anode K: Cathode

<p>MBR20100CL-TA3-T</p> <p>(1)Packing Type (2)Package Type (3)Lead Plating</p>	<p>(1) T: Tube (2) TA3: TO-220, (3) L: Lead Free Plating Blank: Pb/Sn</p>
--	---

■ ELECTRICAL CHARACTERISTICS (Ta=25 , unless otherwise specified)

PARAMETER			SYMBOL	RATINGS	UNIT
Maximum Repetitive Peak Reverse Voltage			V_{RRM}	100	V
Maximum DC Blocking Voltage			V_R	100	V
Working Peak Reverse Voltage			V_{RWM}	100	V
Maximum PMS Reverse Voltage			$V_{R(RMS)}$	70	V
Average Forward Rectified Output Current		Per Leg	I_{OUT}	10	A
		Total Device		20	A
Non-Repetitive Peak Forward Surge Current 8.3ms Single Half-Sine-Wave			I_{FSM}	150	A
Forward Voltage	$T_C=25$	$I_F=10A,$	V_F	0.85	V
		$I_F=20A,$		0.95	V
	$T_C=125$	$I_F=10A,$		0.75	V
		$I_F=20A,$		0.85	V
Maximum DC Reverse Current	$T_C=25$		I_R	0.15	mA
	$T_C=125$			150	mA
Junction Capacitance (Note 1)			C_J	1000	pF
Operating Temperature			T_J	-55 ~ +150	
Storage Temperature			T_{STG}	-55 ~ +150	

Notes.1: Applied $V_R = 4.0V$ and $f = 1.0MHz$.

TYPICAL CHARACTERISTICS

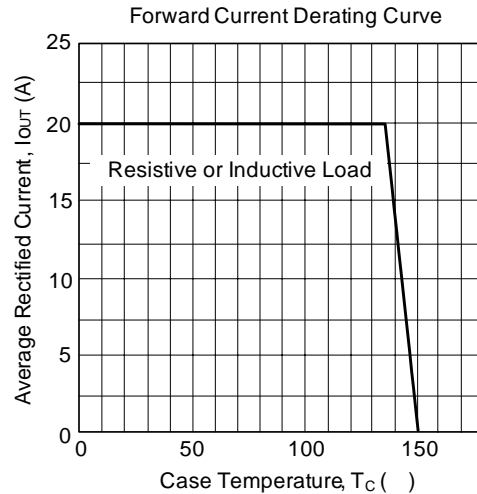
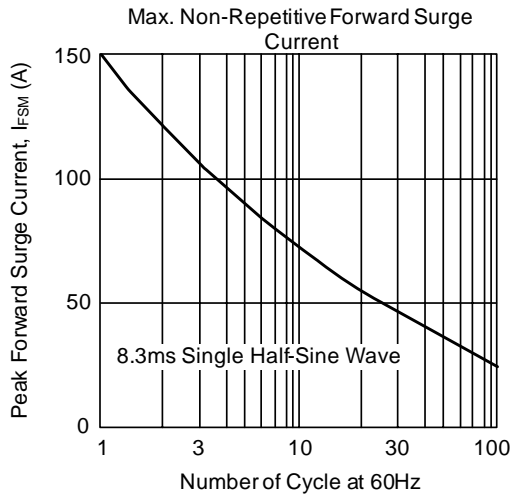
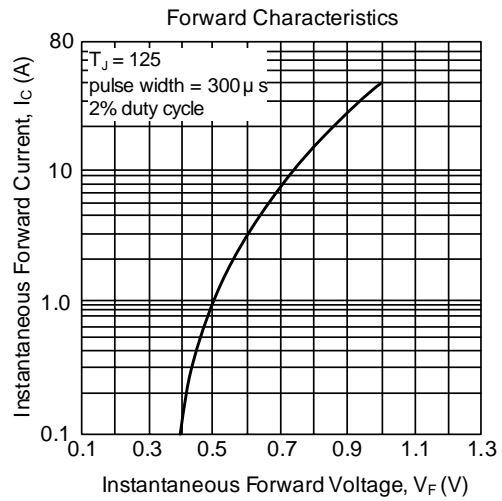
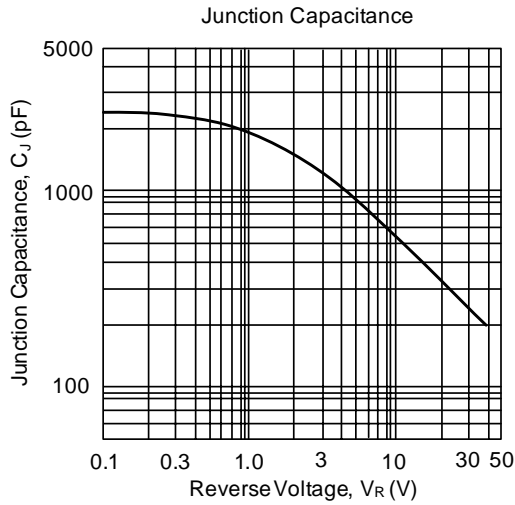

UTC assumes no responsibility for equipment failures that result from using products at values that exceed, even momentarily, rated values (such as maximum ratings, operating condition ranges, or other parameters) listed in products specifications of any and all UTC products described or contained herein. UTC products are not designed for use in life support appliances, devices or systems where malfunction of these products can be reasonably expected to result in personal injury. Reproduction in whole or in part is prohibited without the prior written consent of the copyright owner. The information presented in this document does not form part of any quotation or contract, is believed to be accurate and reliable and may be changed without notice.