

**Description**

The BL0509/0510 is CMOS LSI designed for use on the general infrared ray remote control receiver, and when it is used in combination with BL9148, the remote control system can be constructed.

The BL0509 is DIP 16 Pin type and is capable of controlling 10 functions, while the BL0510 is DIP 24 PIN type and is capable of controlling 18 functions. Except these, the principle and the block diagram of the two circuits are almost the same.

**Pin Assignment**

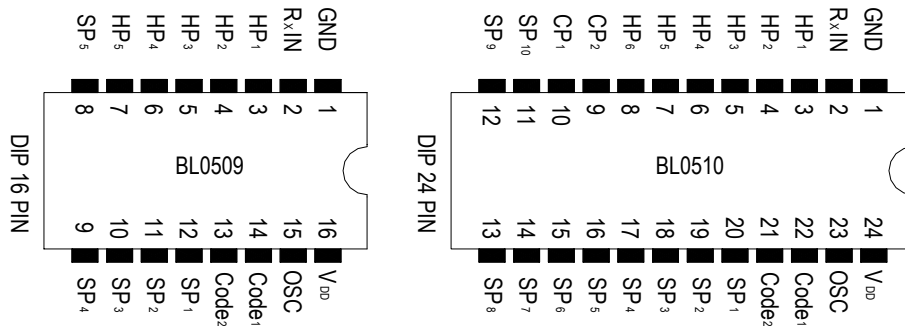

**Features**

- High anti-interference: excellent capability to anti-interfere, such as fluorescent lamp’s ballast, television, etc. No error-code can be output.
- When power on reset period, on pulse can be output from all ports and mal-operation can’t be happened
- Able to output multiple keying signals parallel sent from the BL9148.(The BL0509 is able to output parallel up to 5functions,while the BL0510 is up to 6 functions)
- Single pulse, continuous pulse and cyclic pulse outputs are provided,(Cyclic pulse is available only for BL0510)
- A single terminal type oscillator by means of CR is provided
- Code detection circuit provided for code check with the transmitter preventing interference’s form other types.

**Applications**

Use as remote control transmitters in audios, air conditioners, toys and others.

BL0509 External Circuit

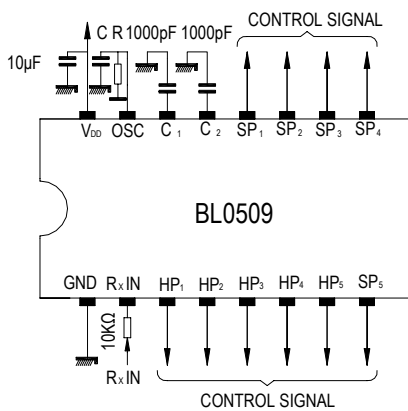

Note: R=39K , C=1000pF

BL0510 External Circuit

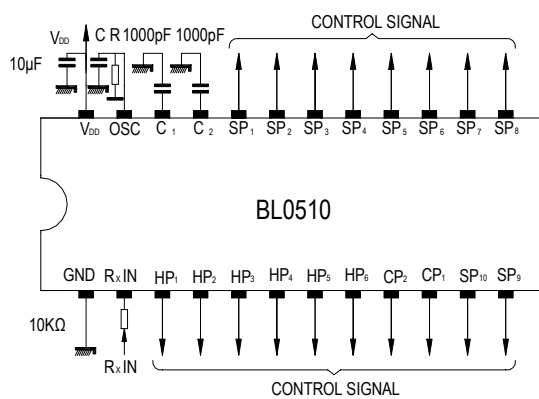

Note: R=39K , C=1000pF