

Type MQ Quick Acting Micro Fuse

MQD0801



Electrical Characteristics (UL/CSA STD. 248-14)

Testing current	Blow Time	
	Minimum	Maximum
100%	4 Hrs.	N/A
200%	N/A	5 Sec

Approvals



Safety Agency Approvals	Amp range / Volt @ I.R. ability
Recognized File No. E20624 Certified File No. LR39772	100mA - 15A/125V @ 50A AC, 300A DC

Environmental Specification

Operating Temperature

-55°C to +125°C

Soldering Heat Resistance

260°C, 10 sec. per IEC 68-2-20

Moisture Resistance

MIL-STD-202F, Method 106

Salt Spray

MIL-STD-202, Method 101, Condition B (48Hrs)

Shock Resistance

MIL-STD-202, Method 213, Condition I (Sawtooth)

Vibration Resistance

10-55 Hz x 3 axis/ no load (MIL-STD-202, Method 201)

Physical Specification

Materials

Body:

Molded with UL Recognized epoxy component plastic, UL 94-V0

LeadWire:

Tin-lead plated Copper,
Diameter 0.025" for 7A and less
Diameter 0.032" for rating above 7A

Marking:

On fuse:
"bel", "MQ", "Current Rating", "125V" printed in white color

On label:

Above info plus "UL SF CE" and interrupting rating

Catalog Number	Ampere Rating	Typical Cold Resistance (ohm)	Volt-drop @100% In (Volt) max.	Melting I ² T < 10 mSec (A ² Sec)	Melting I ² T @10 In (A ² Sec)	Maximum Power Dissipation (W)
MQ 100	100mA	15.5	3.00	0.0007	0.0006	0.35
MQ 125	125mA	2.2	0.61	0.0012	0.0009	0.087
MQ 150	150mA	1.6	0.54	0.0019	0.0015	0.10
MQ 200	200mA	1.2	0.48	0.003	0.002	0.12
MQ 250	250mA	0.85	0.43	0.005	0.004	0.14
MQ 300	300mA	0.62	0.39	0.009	0.008	0.16
MQ 375	375mA	0.49	0.35	0.013	0.012	0.18
MQ 500	500mA	0.33	0.31	0.025	0.023	0.21
MQ 750	750mA	0.19	0.25	0.062	0.056	0.27
MQ 1	1A	0.13	0.22	0.11	0.10	0.33
MQ 1.5	1.5A	0.07	0.18	0.29	0.25	0.42
MQ 2	2A	0.054	0.24	0.33	0.27	0.33
MQ 2.5	2.5A	0.041	0.22	0.59	0.50	0.40
MQ 3	3A	0.031	0.20	1.1	0.9	0.48
MQ 4	4A	0.023	0.19	1.9	1.6	0.58
MQ 5	5A	0.018	0.17	3.4	3.0	0.71
MQ 7	7A	0.012	0.15	8	7	0.9
MQ 10	10A	0.007	0.098	25	21	1.3
MQ 12	12A	0.006	0.093	41	35	1.5
MQ 15	15A	0.004	0.088	70	63	1.8

Consult manufacturer for other ratings

Packaging

- In bulk:
1,000 pcs per box
- On Axial Tape & Reel:
2,500 pcs per reel
- Tape & Reel specification:
per EIA-296-E & IEC 286-1
@ 5mm Pitch and 52.4mm inside Tape Spacing

Mechanical Dimensions

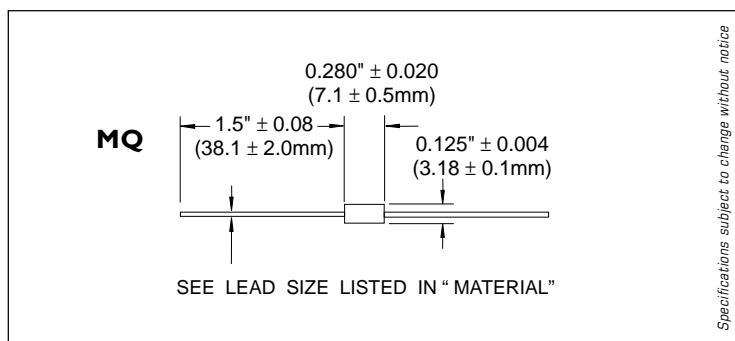

ORDERING INFORMATION SEE PAGES 67 & 68

Type MQ
Quick Acting Micro Fuse

MQ - TIME CURRENT CHARACTERISTIC CURVE

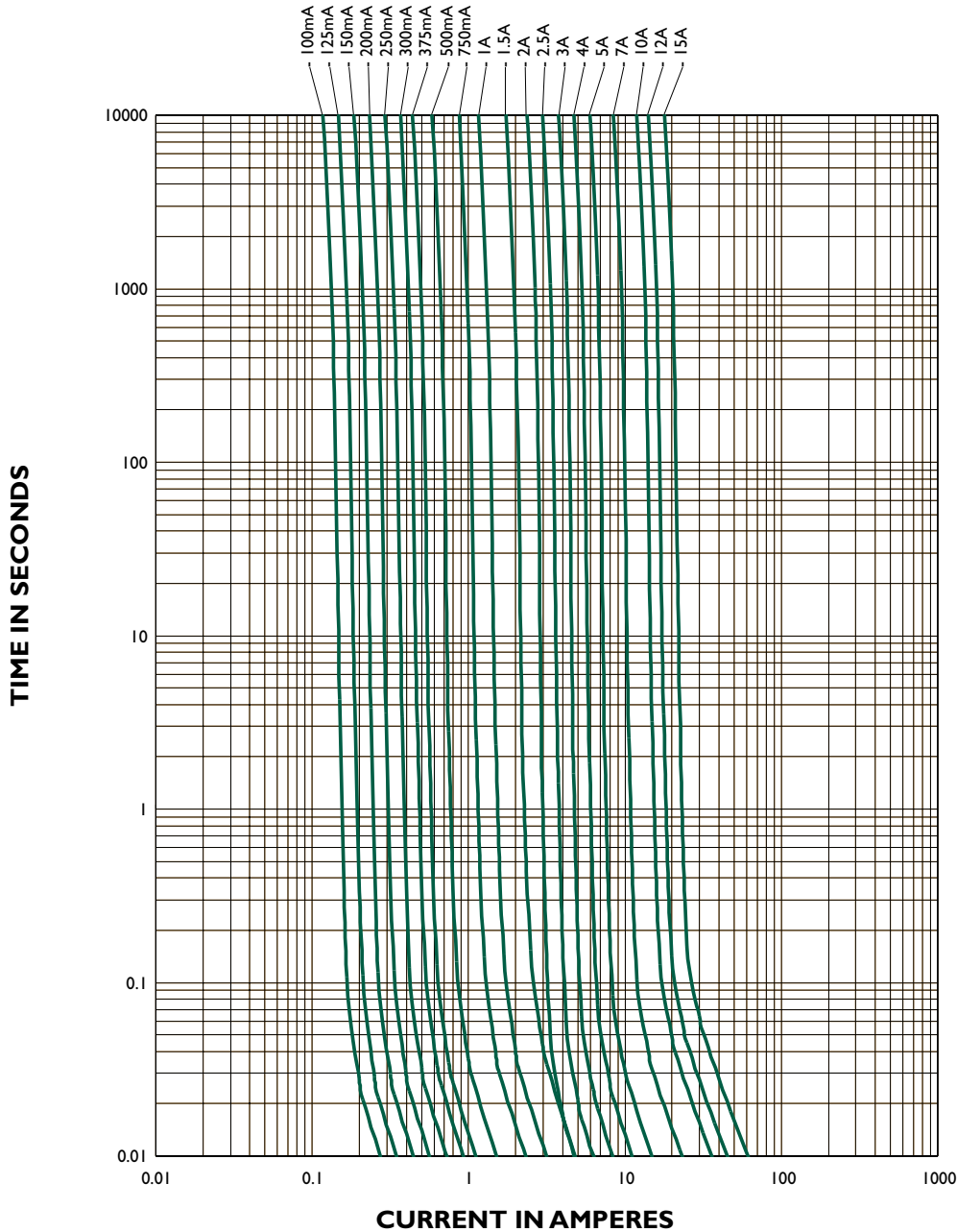

Specifications subject to change without notice

NOTE - see important information under "User Guide" on P.08

Corporate Office
Bel Fuse Inc.
206 Van Vorst Street, Jersey City, NJ 07302
Tel: 201-432-0463
Fax: 201-432-9542
E-Mail: belfuse@belfuse.com
Website: www.belfuse.com

Far East Office
Bel Fuse Ltd.
8F/8 Luk Hop Street
San Po Kong
Kowloon, Hong Kong
Tel: 852-2328-5515
Fax: 852-2352-3706

European Office
Bel Fuse Europe Ltd.
Preston Technology Management Centre
Marsh Lane, Preston PR1 8UD
Lancashire, U.K
Tel: 44-1772-556601
Fax: 44-1772-888366