

Power GaAs MMIC Amplifier

2 - 6.5 GHz

MAAM26100

V 2.00

Features

- +30 dBm Typical Saturated Power
- 19 dB Typical Gain
- 30% Typical Power Added Efficiency
- On-Chip Bias Network
- DC Decoupled RF Input and Output

Electrical Specifications @ $T_A = +25^\circ\text{C}$

Frequency Range	2.0 – 6.5 GHz	
Gain ¹	19.0 dB Typ	15.0 dB Min
VSWR ¹	Input	2.0:1 Typ
	Output	2.2:1 Typ
Saturated Power Output ¹ (Input Power = +14 dBm)	+30 dBm Typ	
Output Power at 1 Gain dB Compression	+28 dBm Typ	
Third Order Intercept	+39 dBm Typ	
Reverse Isolation	30 dB Typ	
Impedance	50 Ω Typ	
Bias Voltage	$V_{DD} = +8 V_{DC}$, $V_{GG} = -1.3 V_{DC}$ Typ	
Bias Current		
No RF	420 mA Typ	
$P_{IN} = +14$ dBm	600 mA Typ	
Thermal Resistance ²	14°C/W Typ	

Maximum Ratings

Voltage	$V_{DD} = +10$ Volts, $V_{GG} = -5$ Volts
Input Power	+23 dBm
Storage Temperature	-65°C to +150°C
Operating Channel Temperature	+150°C

1. 100% on-wafer tested.
2. Attachment method not included.

Schematic

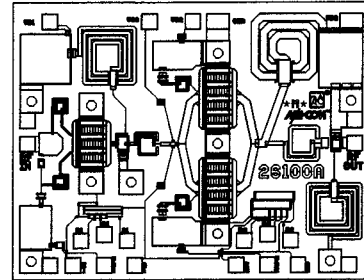
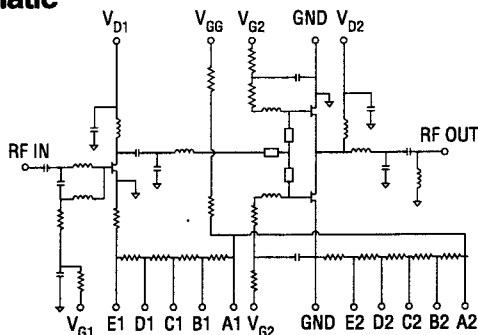

Typical Performance @ +25°C

LINEAR GAIN AND INPUT RETURN LOSS vs FREQUENCY

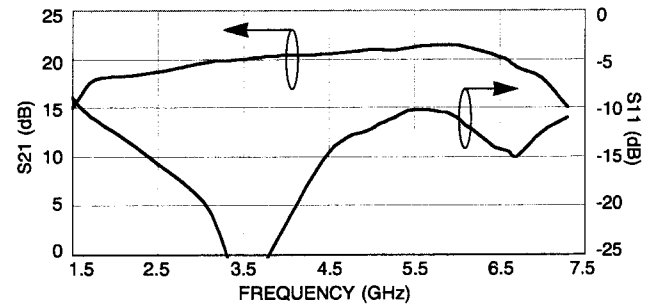

OUTPUT POWER vs FREQUENCY @ $P_{IN} = +14$ dBm

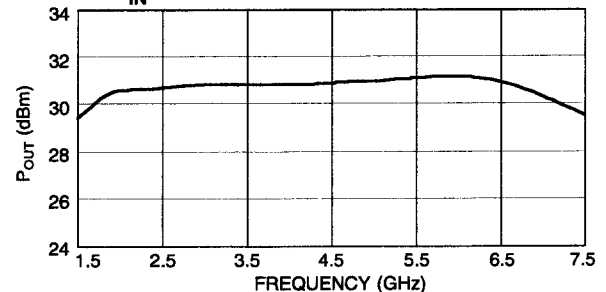

POWER ADDED EFFICIENCY vs FREQUENCY @ $P_{IN} = +14$ dBm

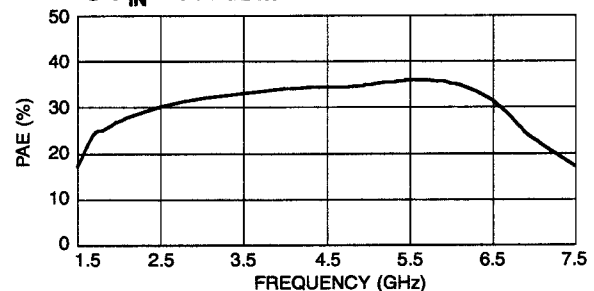

Specifications Subject to Change Without Notice.

11-50

M/A-COM, Inc.

North America: Tel. (800) 366-2266
Fax (800) 618-8883

Asia/Pacific: Tel. +81 (03) 3226-1671
Fax +81 (03) 3226-1451

Europe: Tel. +44 (1344) 869 595
Fax +44 (1344) 300 020

Handling

Permanent damage to the MAAM26100 may occur if the following precautions are not adhered to:

- A. Cleanliness — The MAAM26100 should be handled in a clean environment. DO NOT attempt to clean assembly after the MAAM26100 is installed.
- B. Static Sensitivity — All die handling equipment and personnel should comply with DOD-STD-1686 Class I.
- C. Transients — Avoid instrument and power supply transients while bias is connected to the MAAM26100. Use shielded signal and bias cables to minimize inductive pick-up.
- D. General Handling — DO NOT touch the surface of the die. It is recommended that the MAAM26100 die be handled along the long side with a sharp pair of tweezers.

Mounting

The MAAM26100 is back-metallized with Pd/Ni/Au (100/1,000/30,000Å) metallization. It is recommended that the die be mounted with Au/Sn eutectic preforms. The attachment surface should be clean and flat.

- A. An 80/20 preform is recommended with a work surface temperature of approximately 255°C and a tool temperature of 265°C. When hot 90/5 nitrogen/hydrogen gas is applied, solder temperature should be approximately 290°C.
- B. DO NOT expose the MAAM26100 to a temperature greater than 320°C for more than 20 seconds. No more than 3 seconds of scrubbing should be required for attachment.

Bonding

- A. Ball or wedge bond with 1.0 mil diameter gold wire or 3.0 mil x 0.5 mil ribbon. Thermosonic bonding with a nominal stage temperature of 150°C and a ball bonding force of 40 to 50 grams or wedge bonding force of 18 to 22 grams is recommended. Ultrasonic energy and time should be adjusted to the minimum levels necessary to achieve reliable bonds.
- B. Bonds should be started on the die and terminated on the package.
- C. Bonding pads are 4.0 x 4.0 mils. minimum.

Outline

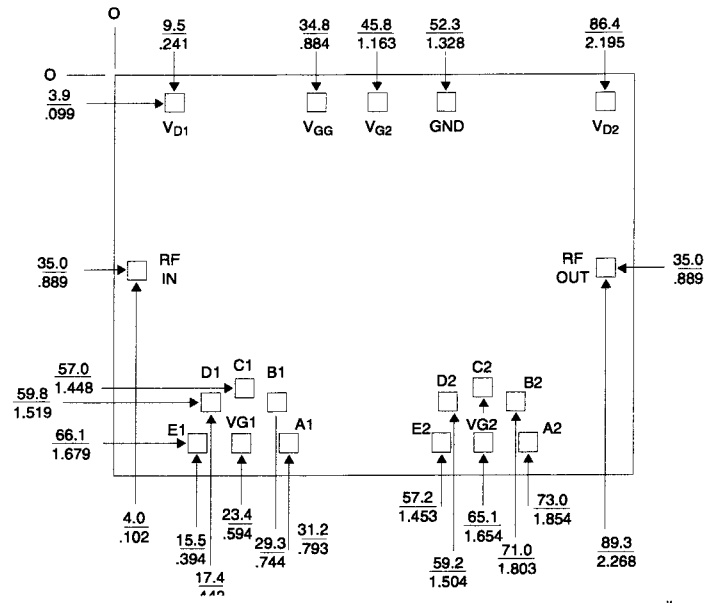

All dimensions are ^{mils}mm.
Die Size 0.091" x 0.070" x 0.004"
(2.319mm x 0.889m x 0.102mm)

Typical Bias Configuration

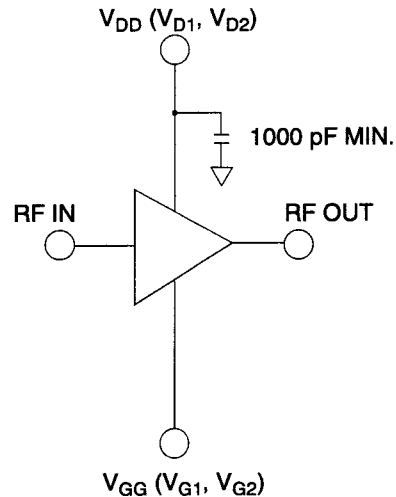

1. Nominal bias is obtained by first connecting -1.2 volts to pads V_{G1} and V_{G2} followed by connecting +8 volts to pads V_{D1} and V_{D2} (note sequence).
2. The recommended V_{DD} range is +6 to +9 volts.
3. Optional on-chip resistor networks are used by connecting a nominal -5 volts to pad V_{GG} then connecting pad "B1", "C1", "D1", or "E1" to pad V_{G1} ; and "B2", "C2", "D2", or "E2" to pad V_{G2} .

Specifications Subject to Change Without Notice.

M/A-COM, Inc.

11-51

North America: Tel. (800) 366-2266 ■ Asia/Pacific: Tel. +81 (03) 3226-1671 ■ Europe: Tel. +44 (1344) 869 595
 Fax (800) 618-8883 Fax +81 (03) 3226-1451 Fax +44 (1344) 300 020