

## ■ OUTLINE

The BL8501 is a CMOS-based PWM step-down DC-DC Converter controller. The device can offer the following advantages: lower supply current and wider operating input-voltage range.

The BL8501 consists of an oscillator, a PWM control circuit, a reference voltage unit, an error amplifier, a soft-start circuit, a protection circuit, a PWM/VFM alternative circuit, a chip enable circuit, and detecting input voltage circuit. A low ripple, high efficiency step-down DC-DC converter can be easily composed of this IC with only several external components, or a power-transistor, an inductor, a diode and capacitors. Output Voltage can be adjusted with external resistors.

## ■ FEATURES

- ◆ Range of input Voltage: 3.5V~12V
- ◆ Built-in Soft-start Function and Protection Function (Reset type protection)
- ◆ Oscillation Frequency: 500KHz
- ◆ High efficiency: 90%
- ◆ High Accuracy Output Voltage:  $\pm 2.0\%$
- ◆ Low Temperature-Drift Coefficient of Output Voltage: Typ:  $\pm 100\text{ppm}/^\circ\text{C}$
- ◆ Operating Temperature Range:  $-20^\circ\text{C}\sim 85^\circ\text{C}$

## ■ APPLICATIONS

- ◆ Power source for hand-held communication equipment, cameras, video instruments such as VCRs, camcorders.
- ◆ Power source for battery-powered equipment.
- ◆ Power source for household electrical appliances.

## ■ PIN CONFIGURATION

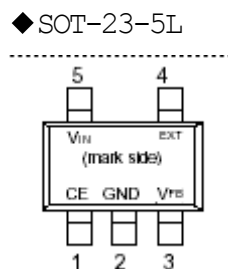

## ■ PIN DESCRIPTION

Pin No.	Symbol	Description
1	CE	Chip Enable Pin (Active with "H")
2	GND	Ground Pin
3	$V_{FB}$	Pin for Feedback Voltage
4	EXT	External Transistor Drive Pin (CMOS Output)
5	$V_{IN}$	Power Supply Pin

## ■ DETAILED DESCRIPTION

The following description refer to the functional block diagram:

### **Error Amplifier**

The error amplifier is a high-gain differential amplifier used to regulate the converter output voltage. The amplifier generates an error signal, which is fed to the PWM comparator. The error signal is generated when a sample of the output voltage is compared to the internal reference and the difference is amplified. The output sample is obtained from  $V_{FB}$ , which is obtained from an external resistive divider connected between output voltage and GND.

### **PWM Comparator**

The PWM comparator generates a series of pulses, which is obtained when the error signal is compared to the oscillator clock. And the series of pulses are used to control the state of the power switch by turning the driver on or off.

### **PWM/VFM controller**

With a PWM/VFM alternative circuit, when the load current is small, the operation is automatically switching into the VFM oscillator from PWM oscillator. Therefore, the efficiency at small load current is improved.

### **Oscillator**

The oscillator circuit provides a 500kHz clock, to set the converter operating frequency, and a timing ramp of slope compensation. The clock waveform is a pulse, a few hundred nanoseconds in duration.

### **Protection circuit**

If the term of maximum duty cycle keeps on a certain time, the embedded protection circuit works. The protection circuit is Reset-type protection circuit, and it works to restart the operation with soft-start and repeat this operation until maximum duty cycle condition is released. When the cause of large load current or something else is removed, the operation is automatically released and returns to normal operation.

### **Soft-Start**

The Soft-Start circuit causes the output voltage to increase to the regulation point at a controlled rate of rise. The voltage on the charging soft-start capacitor gradually raises the reference voltage of the error amplifier to clamp the error signal.

### **UVLO**

UVLO function works when the input voltage is equal or less than UVLO threshold, it makes this IC be standby and suppresses the consumption current and avoids an unstable operation.

### **Enable (CE)**

Logic low on CE puts the BL8501 in standby state. In standby mode, the output power switch, voltage reference, and other functions are shut off, the supply current is reduced to  $1\mu A$  maximum.

**■ ABSOLUTE MAXIMUM RATINGS**

Symbol	Item	Rating	Unit
V <sub>IN</sub>	V <sub>IN</sub> Supply Voltage	12	V
V <sub>EXT</sub>	EXT Pin Output Voltage	-0.3 ~ V <sub>IN</sub> +0.3	V
V <sub>CE</sub>	CE Pin Input Voltage	-0.3 ~ V <sub>IN</sub> +0.3	V
V <sub>F<sub>B</sub></sub>	V <sub>F<sub>B</sub></sub> Pin Input Voltage	-0.3 ~ V <sub>IN</sub> +0.3	V
I <sub>EXT</sub>	EXT Pin Inductor Drive Output Current	±20	mA
PD	Power Dissipation	100	mW
T <sub>opt</sub>	Operating Temperature Range	-20 ~ +85	°C
T <sub>stg</sub>	Storage Temperature Range	-55 ~ +125	°C

**■ ELECTRICAL CHARACTERISTICS**

Symbol	Item	Conditions	Min.	Typ.	Max.	Unit
V <sub>IN</sub>	Operating Input Voltage		3.5		12	V
V <sub>F<sub>B</sub></sub>	Feedback Voltage	V <sub>IN</sub> =V <sub>CE</sub> =8V, I <sub>F<sub>B</sub></sub> =-100mA	0.98	1.00	1.02	V
ΔV <sub>F<sub>B</sub></sub> /ΔT	Feedback Voltage Temperature Coefficient	-20°C ≤ T <sub>opt</sub> ≤ 85°C		± 100		ppm/°C
f <sub>osc</sub>	Oscillator Frequency	V <sub>IN</sub> =V <sub>CE</sub> =8V, I <sub>F<sub>B</sub></sub> =-100mA	400	500	600	KHz
Δf <sub>osc</sub> /ΔT	Oscillator Frequency Temperature Coefficient	-20°C ≤ T <sub>opt</sub> ≤ 85°C		±0.2		%/°C
I <sub>DD1</sub>	Supply Current 1	V <sub>IN</sub> = V <sub>CE</sub> = V <sub>F<sub>B</sub></sub> = 8.0V		65		μA
I <sub>stb</sub>	Standby Current	V <sub>IN</sub> =8.0V, V <sub>CE</sub> = V <sub>F<sub>B</sub></sub> =0V		0	1	μA
I <sub>EXTH</sub>	EXT "H" Output Current	V <sub>IN</sub> = 8V, V <sub>EXT</sub> = 7.9V, V <sub>CE</sub> = 0, V <sub>F<sub>B</sub></sub> = 8V		-7.8		mA
I <sub>EXTL</sub>	EXT "L" Output Current	V <sub>IN</sub> = 8V, V <sub>EXT</sub> = 0.1V, V <sub>CE</sub> = 8V, V <sub>F<sub>B</sub></sub> = 0V		6.1		mA
I <sub>CEH</sub>	CE "H" Input Current	V <sub>IN</sub> = V <sub>CE</sub> = V <sub>F<sub>B</sub></sub> = 8.0V		0	0.5	μA
I <sub>CEL</sub>	CE "L" Input Current	V <sub>IN</sub> = V <sub>F<sub>B</sub></sub> = 8.0V, V <sub>CE</sub> = 0V	-0.5	0		μA
V <sub>CEH</sub>	CE "H" Input Voltage	V <sub>IN</sub> = 8V, V <sub>F<sub>B</sub></sub> = 0V	1.5			V
V <sub>CEL</sub>	CE "L" Input Voltage	V <sub>IN</sub> = 8V, V <sub>F<sub>B</sub></sub> = 0V			0.3	V
Maxdty	Oscillator Maximum Duty Cycle		100			%
T <sub>start</sub>	Delay Time by Soft-start function	V <sub>IN</sub> = 8V, I <sub>F<sub>B</sub></sub> = -10mA V <sub>CE</sub> = 0 → >8V	3	7	10	ms
T <sub>prot</sub>	Delay Time for protection circuit	V <sub>IN</sub> = V <sub>CE</sub> = 8V V <sub>F<sub>B</sub></sub> = 2.5V → >0V	150	200	250	μs

**■ TYPICAL APPLICATION AND APPLICATION HINTS**

Example: Output Voltage=3.3V

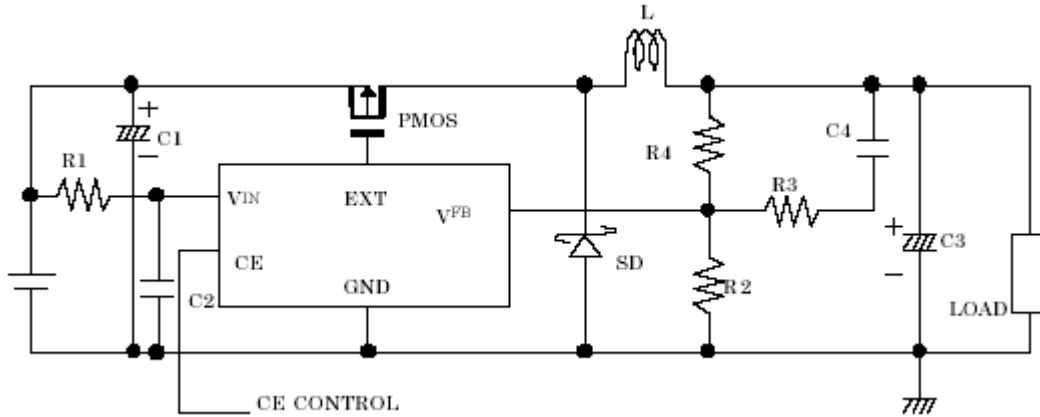

PMOS: SI9435

L: 27  $\mu$ H

SD1: 1N5817

C1: 10  $\mu$ F (Ceramic Type or Electrolytic Type)

C2: 0.1  $\mu$ F (Ceramic Type or Electrolytic Type)

C3: 47  $\mu$ F (Tantalum Type)

C4: 1000pF (Ceramic Type)

R1=10  $\Omega$ , R2=14.3k  $\Omega$ , R3=2.7k  $\Omega$ , R4=33k  $\Omega$

When you use this chip, consider the following issues:

- As shown in the block diagram, a parasitic diode is formed in the terminal, this diode is not formed for load current, therefore do not use it in such a way. When you control the CE pin by another power supply, do not make its "H" level more than the voltage level of  $V_{IN}$  pin.
- Set external components as close as possible to the IC and minimize the connection between the components and the IC. In particular, a capacitor should be connected to  $V_{OUT}$  pin with the minimum connection. Make sufficient ground and reinforce supplying. A large switching current could flow through the connection of power supply, an inductor and the connection of  $V_{OUT}$ . If the impedance of the connection of power supply is high, the voltage level of power supply of the IC fluctuates with the switching current. This may cause unstable operation of the IC.
- Protection circuit may work if the maximum duty cycle continues for the time defined in the electrical characteristics. Once after stopping the output voltage, output will restart with soft-start operation. If the difference between input voltage and output voltage is small, the protection circuit may work.
- Use capacitors with a capacity of 47  $\mu$ F or more for  $V_{OUT}$  pin, and with good high

frequency characteristics such as tantalum capacitors. We recommend you to use output capacitors with an allowable voltage at least twice as much as setting output voltage. This is because there may be a case where a spike –shaped high voltage is generated by an inductor when an external transistor is on and off.

- Choose an inductor that has sufficiently small D.C. resistance and large allowable current and is hard to reach magnetic saturation. And if the value of inductance of an inductor is extremely small, the  $I_{LX}$  may exceed the absolute maximum rating at the maximum loading.  
Use an inductor with appropriate inductance.
- Use a diode of a Schottky type with high switching speed, and also pay attention to its current capacity.
- Do not use this IC under the condition with  $V_{IN}$  voltage at equal or less than minimum operating voltage.
- When the threshold level of an external power MOSFET is rather low and the drive-ability of voltage supplier is small, if the output pin is short circuit, input voltage may be equal or less than UVLO detector threshold. In this case, the device is reset with UVLO function that is different from the reset-protection function caused by maximum duty cycle.
- With the PWM/VFM alternative circuit, when the on duty cycle of switching is 20% or less, the IC alters from PWM mode to VFM mode (Pulse skip mode). The purpose of this circuit is raising the efficiency with a light load by skipping the frequency and suppressing the consumption current. However, the ratio of output voltage against input voltage is 20% or less, (ex.  $V_{IN} > 10V$  and  $V_{OUT} = 2V$ ) even if the large current may be loaded, the IC keeps its VFM mode. As a result, frequency might be decreased, and oscillation waveform might be unstable. These phenomena are the typical characteristics of the IC with PWM/VFM alternative circuit.

★ The performance of power source circuits using this IC extremely depends upon the peripheral circuits. Pay attention in the selection of the peripheral circuits. In particular, design the peripheral circuits in a way that the values such as voltage, current, and power of each component, PCB patterns and the IC does not exceed their respected rated values.

### ■ How to Adjust Output Voltage and about Phase Compensation

As for adjustable Output type, feedback pin ( $V_{FB}$ ) voltage is controlled to maintain 1.0V.

Output Voltage,  $V_{OUT}$  is as following equation:

$$V_{OUT} : (R2+R4) = V_{FB} : R2$$

$$V_{OUT} = V_{FB} * (R2+R4) / R2$$

Thus, with changing the value of R2 and R4, output voltage can be set in the specified range. In the DC-DC converter, with the load current and external components such as L and C, phase might be behind 180 degree. In this case, the phase margin of the system will be less and stability will be worse. To prevent this, phase margin should be secured with proceeding the phase. A pole is formed with external components L and C3.

$$F_{pole} \sim 1/2 \pi \sqrt{L \times C3}$$

A zero (signal back to zero) is formed with R4 and C4.

$$\cong F_{zero} \sim 1/(2\pi \times R4 \times C4)$$

For example, if L=27  $\mu$ H, C3=47  $\mu$ F, the cut off frequency of the pole is approximately 4.5kHz. To make the cut off frequency of the pole as much as 4.5kHz, set R4=33  $k\Omega$  and C4=1000pF. If  $V_{OUT}$  is set at 5.5V, R2=7.3  $k\Omega$  is appropriate.

R3 prevents feedback of the noise to  $V_{FB}$  pin, about 2.7  $k\Omega$  is appropriate value.

## ■ External Components

### 1. Inductor

Select an inductor that peak current does not exceed  $IL_{max}$ . If larger current than allowable current flows, magnetic saturation occurs and makes transform efficiency worse. When the load current is definite, the smaller value of L, the larger the ripple current. Provided that the allowable current is large in that case and DC current is small, therefore, for large output current, efficiency is better than using an inductor with a large value of L and vice versa.

### 2. Diode

Use a diode with low  $V_F$  (Schottky type is recommended.) and high switching speed.

Reverse voltage rating should be more than  $V_{IN}$  and current rating should be equal or more than  $IL_{max}$ .

### 3. Capacitors

As for  $C_{IN}$ , use a capacitor with low ESR (Equivalent Series Resistance) and a capacity of at least 10  $\mu$ F for stable operation.

$C_{OUT}$  can reduce ripple of Output Voltage, therefore 47  $\mu$ F or more value of tantalum type capacitor is recommended.

### 4. Lx Transistor

Pch Power MOSFET is required for this IC.

Its breakdown voltage between gate and source should be a few V higher than Input Voltage. In the case of Input Voltage is low, to turn on MOSFET completely, to use a MOSFET with low threshold voltage is effective.

If a large load current is necessary for your application and important, choose a MOSFET with low ON resistance for good efficiency.

If a small load current is mainly necessary for your application, choose a MOSFET with low gate capacity for good efficiency.

Maximum continuous drain current of MOSFET should be larger than peak current,

## ■ TEST CIRCUITS

### 1、 $V_{FB}$ (Feedback Voltage)

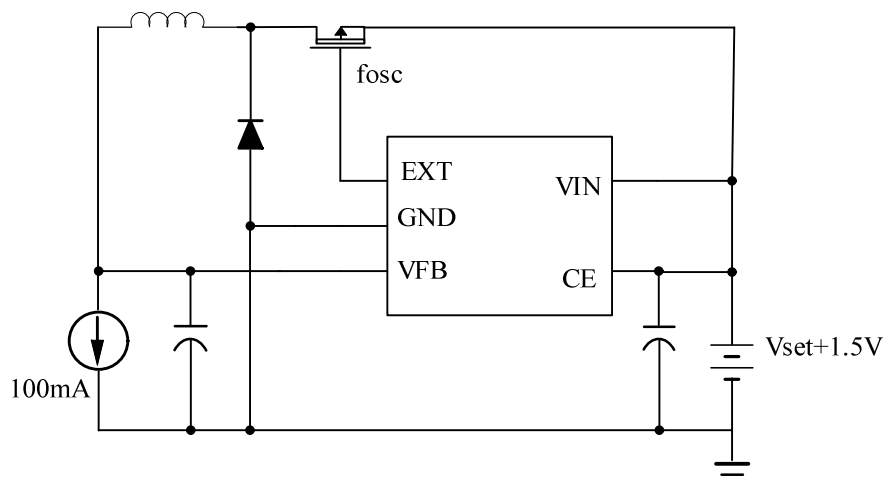

### 2、 $f_{osc}$ (Oscillator frequency)

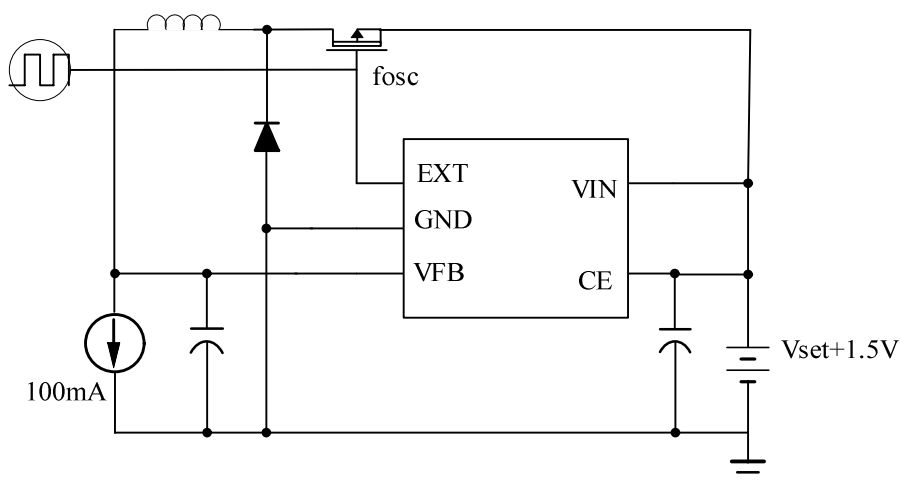

3、 $I_{DD}$  (Supply current)

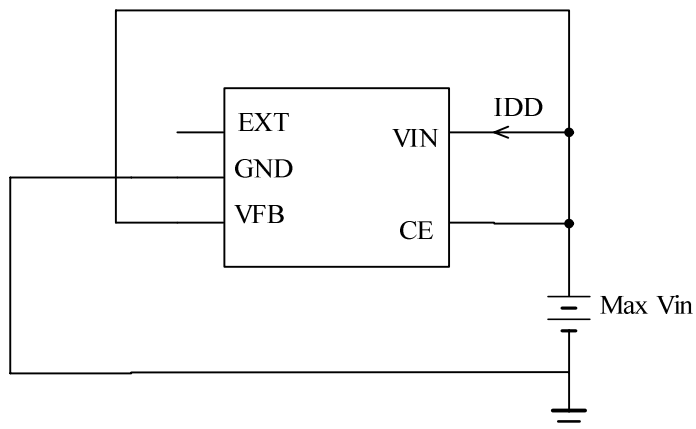

4、 $I_{stb}$  (Standby current)

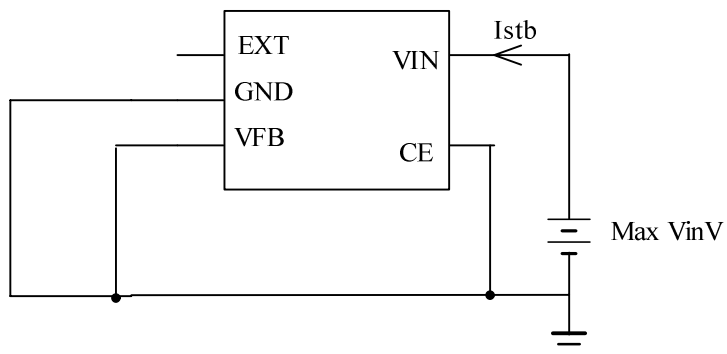

5、 $I_{EXTH}$  (EXT "H" Output Current)

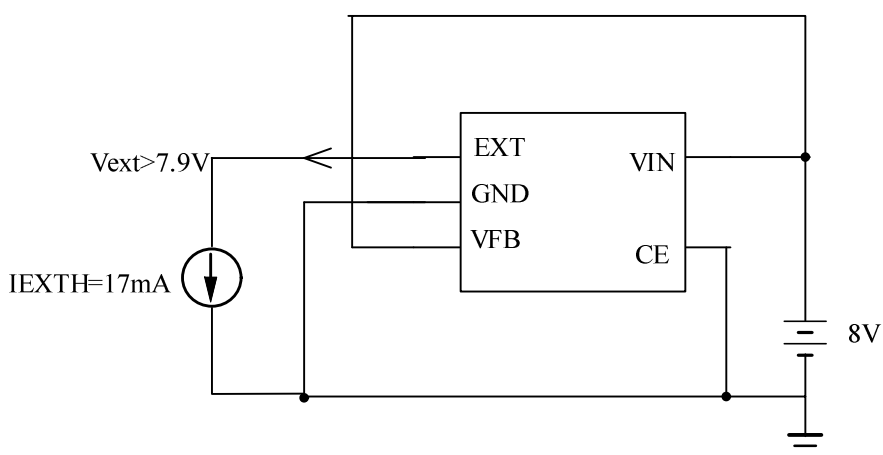



6、  $I_{EXTL}$  (EXT "L" Output Current)

Embedded protection circuit works.

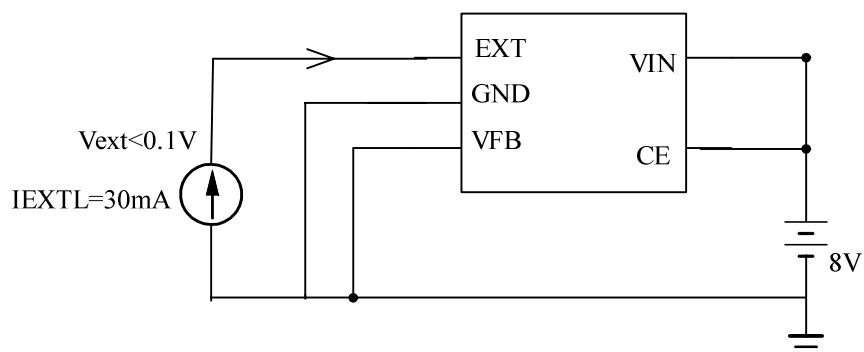

7、  $I_{CEH}$  (CE "H" input current)

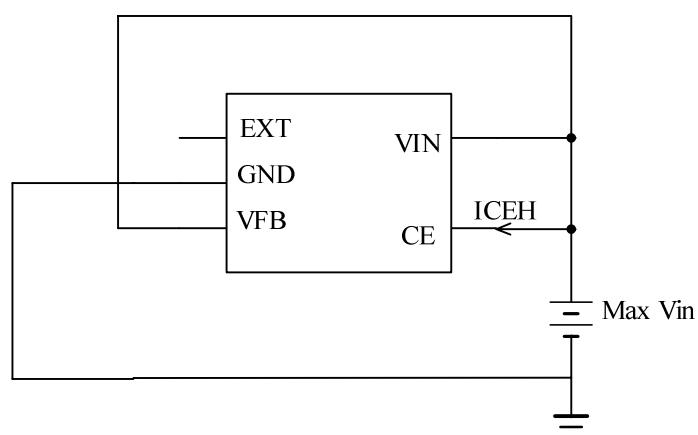

8、  $I_{CEL}$  (CE "L" input current)

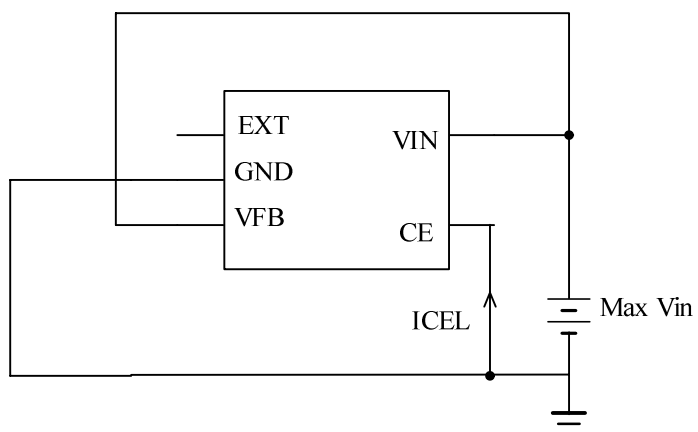

9、 $T_{start}$  (Delay Time by Soft-Start function)

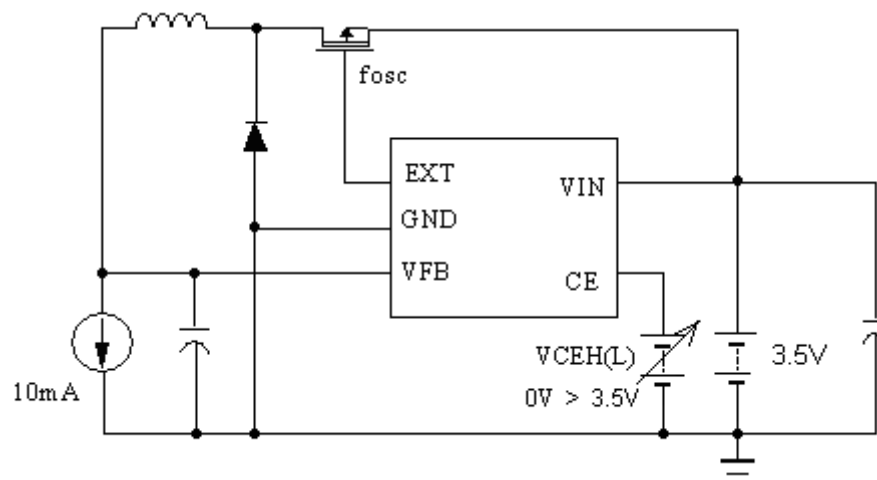

10、 $T_{prot}$  (Delay Time by protection circuit)

