

M61540FP

6ch Electronic Volume with 5 Input Selector

REJ03F0117-0100Z

Rev.1.0

May.31.2004

Description

M61540FP is an audio signal processor for home audio. This IC contains 6 channel electronic volume, gain control, input selector and 2 band tone control.

Features

- Electric Volume 6 channel independent Electronic Volume with High Voltage Transistor.
(0 to -99dB/1dBstep, -∞dB)
- Gain Control 6 channel independent Gain Control (0, 6, 12, 18dB)
- Input Selector L/R channel 5 Input Selector
- Multi Channel Input 6 channel Input
- Tone Control Bass: -14 to + 14dB(2dB step),
Treble: -14 to + 14dB(2dB step)
- REC Output Can use 2 Input for REC Output
- ADC Out Built-in ADC out

Recommended Operating Condition

Supply Voltage Range AVCC = 7.0V(typ), AVEE = -7.0V(typ), DVDD = 3.0 to 5.5V

System Block Diagram

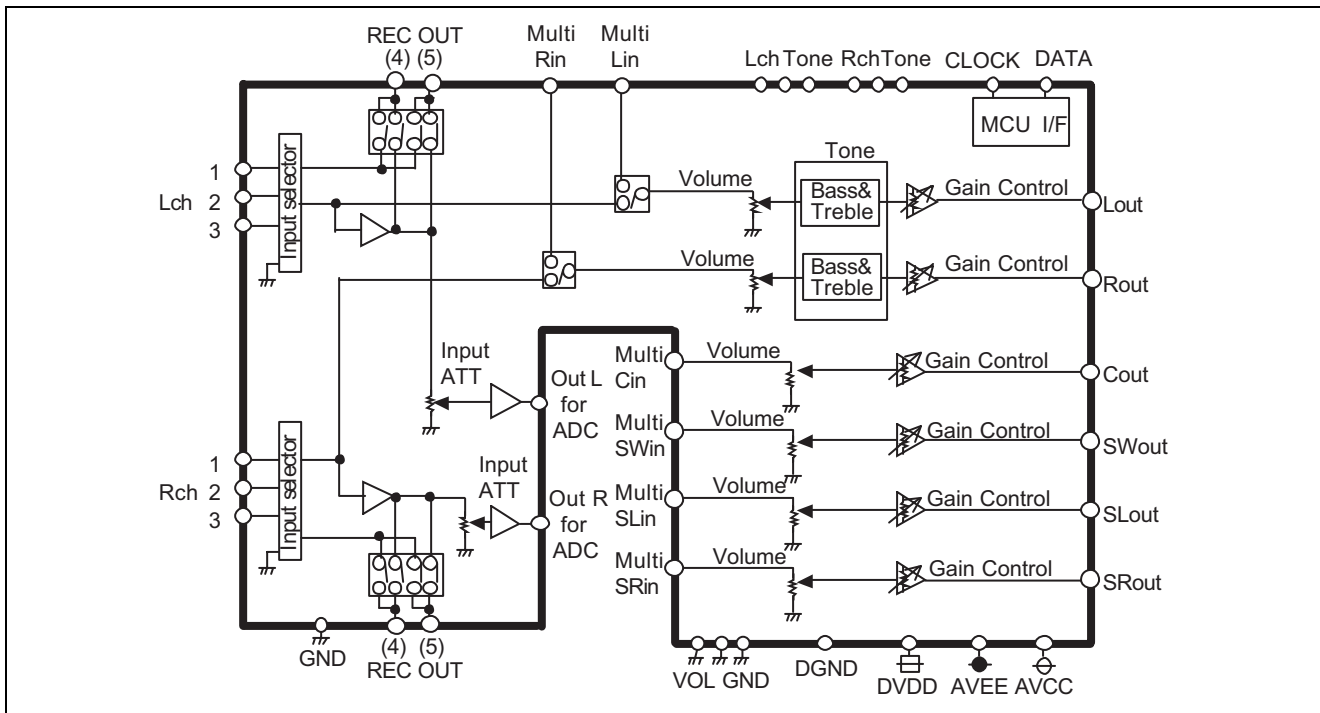

Block Diagram and Pin Configuration

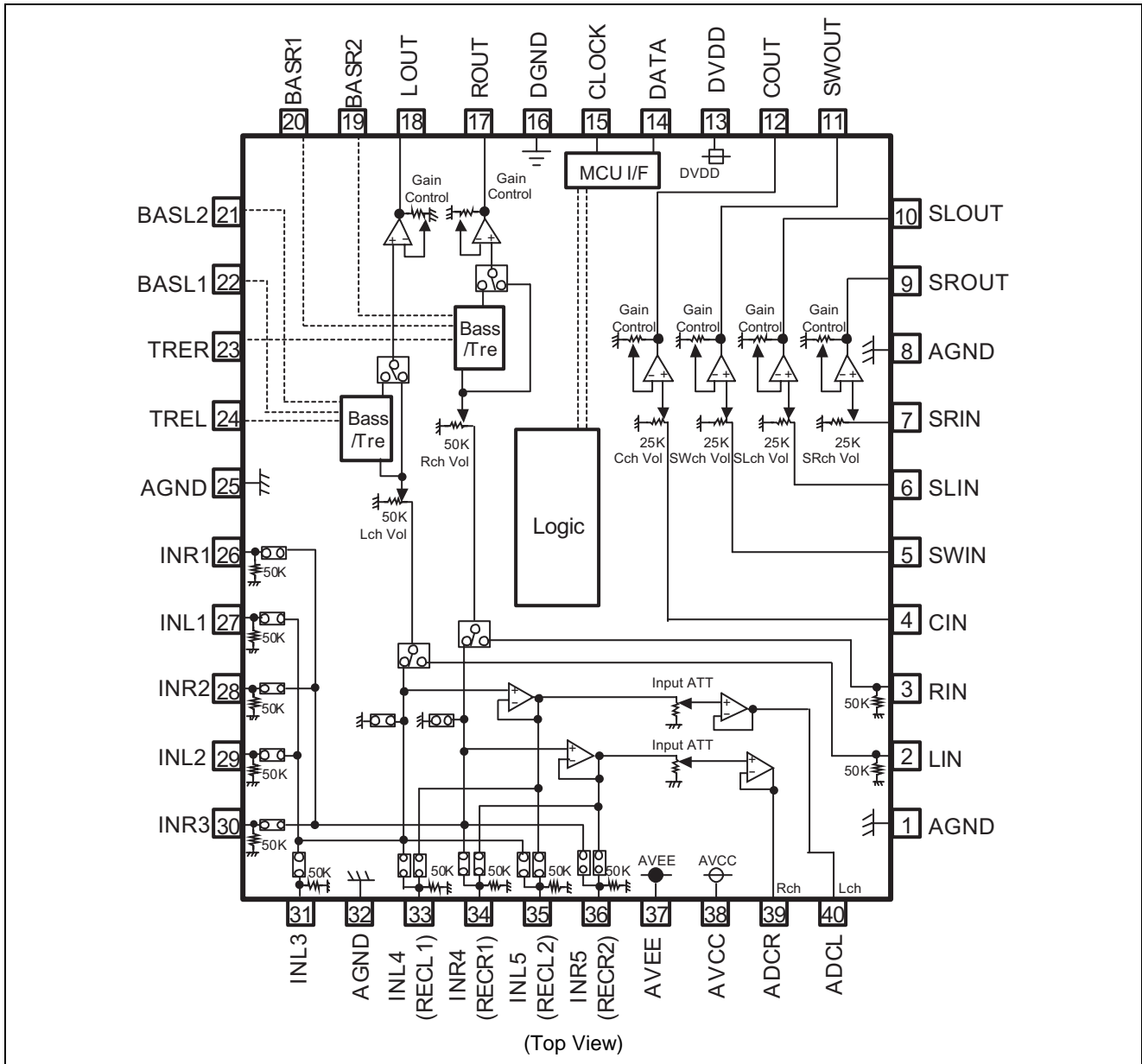

Pin Description

Pin No.	Name	Function
1, 8, 25, 32	AGND	Analog Ground
2	LIN	Input pin of L channel (Multi)
3	RIN	Input pin of R channel (Multi)
4	CIN	Input pin of C channel (Multi)
5	SWIN	Input pin of SW channel (Multi)
6	SLIN	Input pin of SL channel (Multi)
7	SRIN	Input pin of SR channel (Multi)
9	SROUT	Output pin of SR channel
10	SLOUT	Output pin of SL channel
11	SWOUT	Output pin of SW channel
12	COUT	Output pin of C channel
13	DVDD	Power supply to internal logic circuit
14	DATA	Input pin of control data
15	CLOCK	Input pin of control clock
16	DGND	Ground of internal logic circuit
17	ROUT	Output pin of R channel
18	LOUT	Output pin of L channel
19, 20	BASR1, BASR2	Frequency characteristic setting pin of R channel tone control (BASS)
21, 22	BASL1, BASL2	Frequency characteristic setting pin of L channel tone control (BASS)
23	TRER	Frequency characteristic setting pin of R channel tone control (Treble)
24	TREL	Frequency characteristic setting pin of L channel tone control (Treble)
26, 28, 30	INR1, 2, 3	Input pin of R channel (Input Selector)
27, 29, 31	INL1, 2, 3	Input pin of L channel (Input Selector)
33, 35	INL4, 5/ RECL1, 2	Input pin of L channel (Input Selector) can use REC output pin
34, 36	INR4, 5/ RECR1, 2	Input pin of R channel (Input Selector) can use REC output pin
37	AVEE	Negative power supply to internal analog circuit
38	AVCC	Positive power supply to internal analog circuit
39, 40	ADCR, ADCL	Output pin for ADC

Absolute Maximum Ratings

Parameter	Symbol	Ratings	Unit	Condition
Power Supply	Supply Voltage	16	V	AVCC-AVEE
		6		DVDD-DGND
Power dissipation	Pd	1.46	W	Ta≤25°C
Thermal derating	K	85.3	mW/°C	Ta>25°C
Operating temperature	Topr	-20 to +75	°C	
Storage temperature	Tstg	-40 to +125	°C	

Note: AVEE≤DGND<DVDD≤AVCC

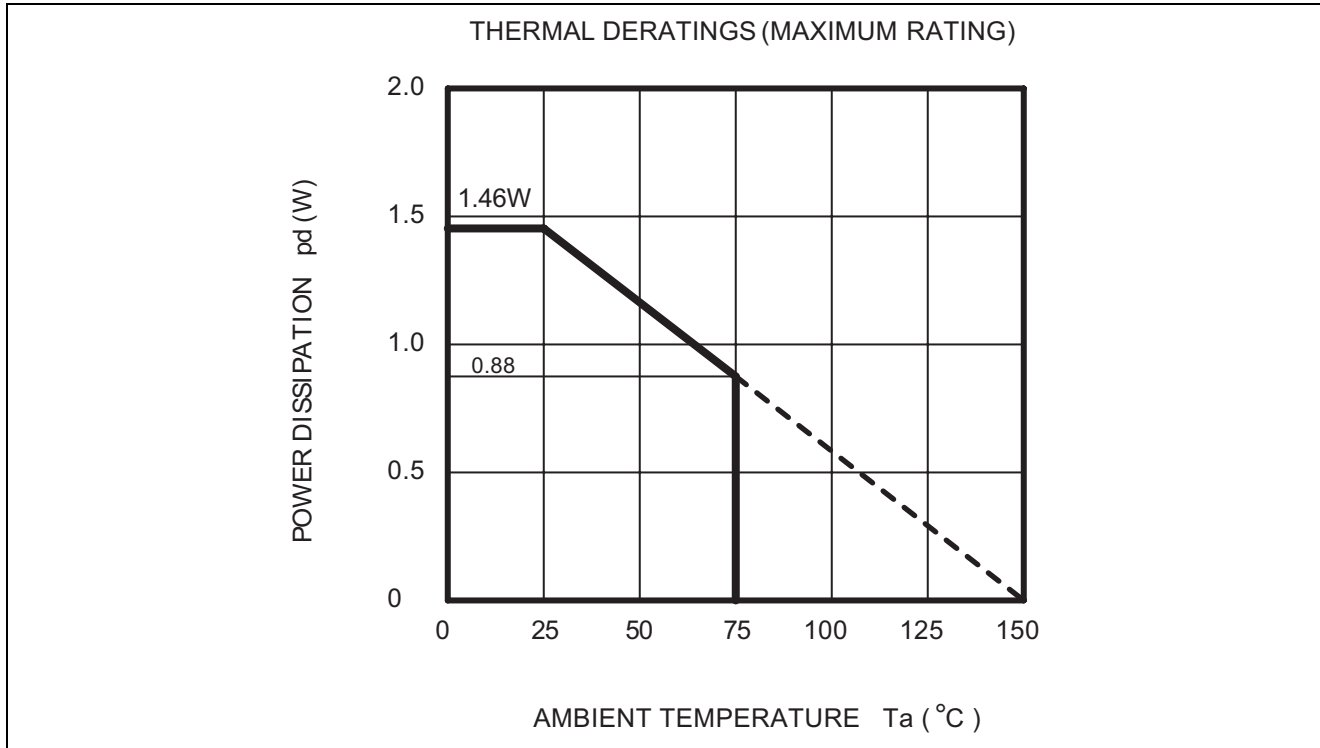

Recommended Operating Conditions

(Ta=25°C, unless otherwise noted.)

Parameter	Symbol	Min	Typ	Max	Unit	Condition
Analog Supply Voltage (Positive)	AVCC	4.5	7.0	7.5	V	
Analog Supply Voltage (Negative)	AVEE	-7.5	-7.0	-4.5	V	
Digital Supply Voltage	DVDD	3.0	3.3	5.5	V	
Logic "H" level Input Voltage	VIH	DVDD×0.7	—	DVDD	V	DGND reference
Logic "L" level Input Voltage	VIL	DGND	—	DVDD×0.2	V	DGND reference

Note: AVEE≤DGND<DVDD≤AVCC

Relationship Between Data and Clock

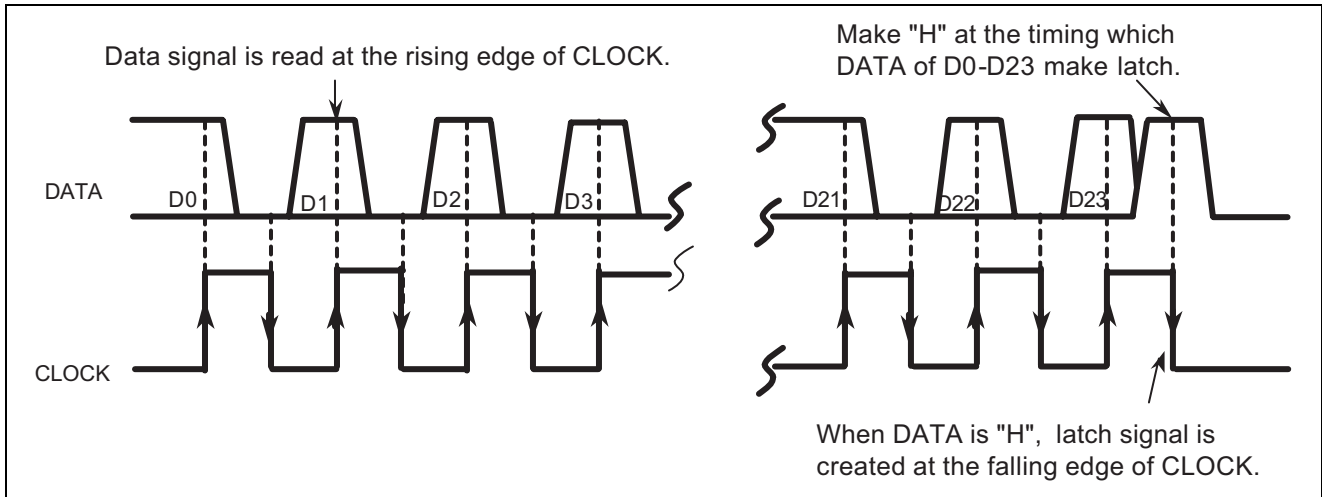

Clock and Data Timings

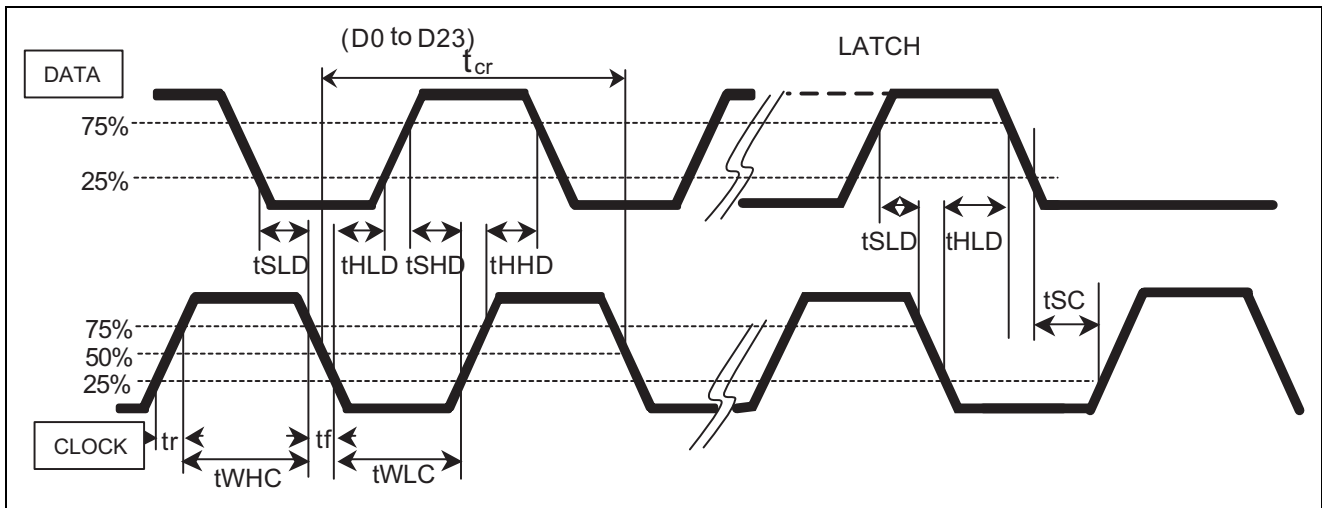

Timing Definition of Digital Block

Parameter	Symbol	Limits			Unit
		Min	Typ	Max	
CLOCK cycle time	tcr	8	—	—	
CLOCK pulse width ("H" level)	tWHC	3.2	—	—	
CLOCK pulse width ("L" level)	tWLC	3.2	—	—	
Rising time of clock and data	tr	—	—	0.8	μs
Falling time of clock and data	tf	—	—	0.8	
DATA setup time (Rising time of clock)	tSHD	1.6	—	—	
DATA setup time (Falling time of clock)	tSLD	1.6	—	—	
DATA hold time ("H" level)	tHHD	1.6	—	—	
DATA hold time ("L" level)	tHLD	1.6	—	—	
CLOCK setup time	tSC	1.6	—	—	

Power on Reset

This IC built-in the power on reset function.

The voltage of DVDD (13 pin) -DGND (16 pin) less than 2.6V, the serial DATA can not accept.

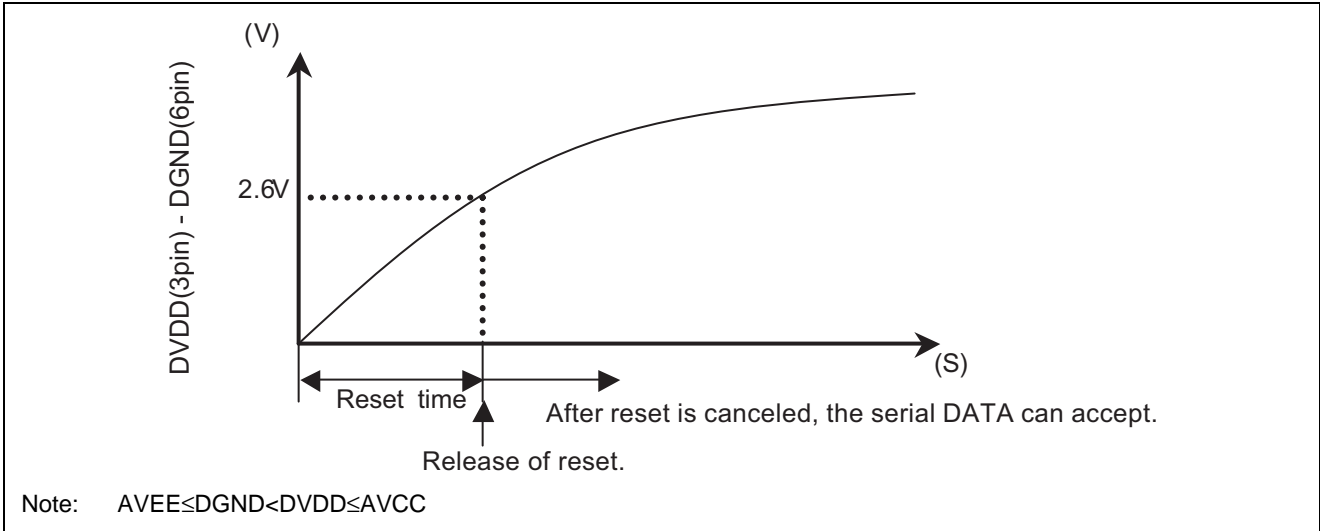

Data Control Specification

Initialize all data of the 4 formats when Digital Power supply (DVDD) turns on.

Prohibit using except specified Data code as follows.

Slot1																								
D0a	D1a	D2a	D3a	D4a	D5a	D6a	D7a	D8a	D9a	D10a	D11a	D12a	D13a	D14a	D15a	D16a	D17a	D18a	D19a	D20a	D21a	D22	D23	
(1) Input Selector		(2) REC Output		(3) ADC Input ATT		(4) L/R Vol Input		(5) Bass/ Tone control Bypass				(6) Treble				0	0	0	0	0	0	0	0	0

Slot2																								
D0b	D1b	D2b	D3b	D4b	D5b	D6b	D7b	D8b	D9b	D10b	D11b	D12b	D13b	D14b	D15b	D16b	D17b	D18b	D19b	D20b	D21b	D22	D23	
(7) Lch Gain Control		(8) Lch Volume						(7) Rch Gain Control		(8) Rch Volume						0	0	0	0	0	0	0	0	1

Slot3																									
D0c	D1c	D2c	D3c	D4c	D5c	D6c	D7c	D8c	D9c	D10c	D11c	D12c	D13c	D14c	D15c	D16c	D17c	D18c	D19c	D20c	D21c	D22	D23		
(7) Cch Gain Control		(8) Cch Volume						(7) SWch Gain Control		(8) SWch Volume						0	0	0	0	0	0	0	0	1	0

Slot4																									
D0d	D1d	D2d	D3d	D4d	D5d	D6d	D7d	D8d	D9d	D10d	D11d	D12d	D13d	D14d	D15d	D16d	D17d	D18d	D19d	D20d	D21d	D22	D23		
(7) SLch Gain Control		(8) SLch Volume						(7) SRch Gain Control		(8) SRch Volume						0	0	0	0	0	0	0	0	1	1

Note: No guarantee except for these codes.

Setting Code

 It's initial setting when power is turned on.

(1) Input Selector

Setting	D0a	D1a	D2a
ALL OFF	0	0	0
IN1	0	1	0
IN2	1	0	0
IN3	1	1	0
IN4*	0	0	1
IN5*	0	1	1

Note: *No guarantee except for these codes.

(2) REC Output

REC Output	REC1	REC2
Setting	D3a	D4a
OFF	0	0
ON	1 ^{*1}	1 ^{*2}

*1: When IN4 selected, REC1 can not use.

IN4	REC1	D0a	D1a	D2a	D3a
ON	OFF	0	0	1	1

*2: When IN5 selected, REC2 can not use.

IN5	REC2	D0a	D1a	D2a	D4a
ON	OFF	0	1	1	1

(3) ADC Input ATT

ATT Setting	D5a	D6a
0dB	0	0
-6dB	0	1
-12dB	1	0
-18dB	1	1

(4) L/R Volume Input

Setting	D7a
Selector In	0
Multi In	1

 It's initial setting when power is turned on.

(5) Bass/Bypass

ATT Setting	D8a	D9a	D10a	D11a
+14dB	1	1	1	1
+12dB	1	1	1	0
+10dB	1	1	0	1
+8dB	1	1	0	0
+6dB	1	0	1	1
+4dB	1	0	1	0
+2dB	1	0	0	1
0dB	1	0	0	0
-2dB	0	0	0	1
-4dB	0	0	1	0
-6dB	0	0	1	1
-8dB	0	1	0	0
-10dB	0	1	0	1
-12dB	0	1	1	0
-14dB	0	1	1	1
Bypass*3	0	0	0	0

*3: Tone control is bypass.

(6) Treble

ATT Setting	D12a	D13a	D14a	D15a
+14dB	1	1	1	1
+12dB	1	1	1	0
+10dB	1	1	0	1
+8dB	1	1	0	0
+6dB	1	0	1	1
+4dB	1	0	1	0
+2dB	1	0	0	1
0dB	1/0	0	0	0
-2dB	0	0	0	1
-4dB	0	0	1	0
-6dB	0	0	1	1
-8dB	0	1	0	0
-10dB	0	1	0	1
-12dB	0	1	1	0
-14dB	0	1	1	1

(7) Gain Control

ATT Setting	Lch	D0b	D1b
	Rch	D9b	D10b
	Cch	D0c	D1c
	SWch	D9c	D10c
	SLch	D0d	D1d
	SRch	D9d	D10d
0dB		0	0
6dB		0	1
12dB		1	0
18dB		1	1

(8) 6ch Volume

 It's initial setting when power is turned on.

	Lch	D2b	D3b	D4b	D5b	D6b	D7b	D8b
	Rch	D11b	D12b	D13b	D14b	D15b	D16b	D17b
	Cch	D2c	D3c	D4c	D5c	D6c	D7c	D8c
ATT	SWch	D11c	D12c	D13c	D14c	D15c	D16c	D17c
	SLch	D2d	D3d	D4d	D5d	D6d	D7d	D8d
	SRch	D11d	D12d	D13d	D14d	D15d	D16d	D17d
0dB	0	0	0	0	0	0	0	0
-1dB	0	0	0	0	0	0	0	1
-2dB	0	0	0	0	0	0	1	0
-3dB	0	0	0	0	0	0	1	1
-4dB	0	0	0	0	0	1	0	0
-5dB	0	0	0	0	0	1	0	1
-6dB	0	0	0	0	0	1	1	0
-7dB	0	0	0	0	0	1	1	1
-8dB	0	0	0	0	1	0	0	0
-9dB	0	0	0	0	1	0	0	1
-10dB	0	0	0	0	1	0	1	0
-11dB	0	0	0	0	1	0	1	1
-12dB	0	0	0	0	1	1	0	0
-13dB	0	0	0	0	1	1	0	1
-14dB	0	0	0	0	1	1	1	0
-15dB	0	0	0	0	1	1	1	1
-16dB	0	0	0	1	0	0	0	0
-17dB	0	0	0	1	0	0	0	1
-18dB	0	0	0	1	0	0	1	0
-19dB	0	0	0	1	0	0	1	1
-20dB	0	0	0	1	0	1	0	0
-21dB	0	0	0	1	0	1	0	1
-22dB	0	0	0	1	0	1	1	0
-23dB	0	0	0	1	0	1	1	1
-24dB	0	0	0	1	1	0	0	0
-25dB	0	0	0	1	1	0	0	1
-26dB	0	0	0	1	1	0	1	0
-27dB	0	0	0	1	1	0	1	1
-28dB	0	0	0	1	1	1	0	0
-29dB	0	0	0	1	1	1	0	1
-30dB	0	0	0	1	1	1	1	0
-31dB	0	0	0	1	1	1	1	1
-32dB	0	0	1	0	0	0	0	0
-33dB	0	0	1	0	0	0	0	1
-34dB	0	0	1	0	0	0	1	0
-35dB	0	0	1	0	0	0	1	1
-36dB	0	0	1	0	0	1	0	0
-37dB	0	0	1	0	0	1	0	1
-38dB	0	0	1	0	0	1	1	0
-39dB	0	0	1	0	0	1	1	1
-40dB	0	0	1	0	0	0	0	0

	Lch	D2b	D3b	D4b	D5b	D6b	D7b	D8b
	Rch	D11b	D12b	D13b	D14b	D15b	D16b	D17b
	Cch	D2c	D3c	D4c	D5c	D6c	D7c	D8c
ATT	SWch	D11c	D12c	D13c	D14c	D15c	D16c	D17c
	SLch	D2d	D3d	D4d	D5d	D6d	D7d	D8d
	SRch	D11d	D12d	D13d	D14d	D15d	D16d	D17d
-41dB	0	1	0	1	0	0	1	1
-42dB	0	1	0	1	0	1	0	0
-43dB	0	1	0	1	0	1	1	1
-44dB	0	1	0	1	1	0	0	0
-45dB	0	1	0	1	1	0	1	1
-46dB	0	1	0	1	1	1	1	0
-47dB	0	1	0	1	1	1	1	1
-48dB	0	1	1	0	0	0	0	0
-49dB	0	1	1	0	0	0	0	1
-50dB	0	1	1	0	0	1	1	0
-51dB	0	1	1	0	0	1	1	1
-52dB	0	1	1	0	1	0	0	0
-53dB	0	1	1	0	1	0	1	1
-54dB	0	1	1	0	1	1	1	0
-55dB	0	1	1	0	1	1	1	1
-56dB	0	1	1	1	0	0	0	0
-57dB	0	1	1	1	0	0	0	1
-58dB	0	1	1	1	0	1	1	0
-59dB	0	1	1	1	0	1	1	1
-60dB	0	1	1	1	1	0	0	0
-61dB	0	1	1	1	1	0	1	1
-62dB	0	1	1	1	1	1	1	0
-63dB	0	1	1	1	1	1	1	1
-64dB	1	0	0	0	0	0	0	0
-65dB	1	0	0	0	0	0	0	1
-66dB	1	0	0	0	0	1	1	0
-67dB	1	0	0	0	0	1	1	1
-68dB	1	0	0	0	1	0	0	0
-69dB	1	0	0	0	1	0	0	1
-70dB	1	0	0	0	1	1	1	0
-71dB	1	0	0	0	1	1	1	1
-72dB	1	0	0	1	0	0	0	0
-73dB	1	0	0	1	0	0	0	1
-74dB	1	0	0	1	0	1	1	0
-75dB	1	0	0	1	0	1	1	1
-76dB	1	0	0	1	1	0	0	0
-77dB	1	0	0	1	1	0	0	1
-78dB	1	0	0	1	1	1	1	0
-79dB	1	0	0	1	1	1	1	1
-80dB	1	0	1	0	0	0	0	0
-81dB	1	0	1	0	0	0	0	1
-82dB	1	0	1	0	0	1	1	0
-83dB	1	0	1	0	0	1	1	1
-84dB	1	0	1	0	1	0	0	0

	Lch	D2b	D3b	D4b	D5b	D6b	D7b	D8b
	Rch	D11b	D12b	D13b	D14b	D15b	D16b	D17b
	Cch	D2c	D3c	D4c	D5c	D6c	D7c	D8c
ATT	SWch	D11c	D12c	D13c	D14c	D15c	D16c	D17c
	SLch	D2d	D3d	D4d	D5d	D6d	D7d	D8d
	SRch	D11d	D12d	D13d	D14d	D15d	D16d	D17d
-85dB	1	0	1	0	1	0	1	1
-86dB	1	0	1	0	1	1	1	0
-87dB	1	0	1	0	1	1	1	1
-88dB	1	0	1	1	0	0	0	0
-89dB	1	0	1	1	0	0	0	1
-90dB	1	0	1	1	0	1	1	0
-91dB	1	0	1	1	0	1	1	1
-92dB	1	0	1	1	1	1	0	0
-93dB	1	0	1	1	1	1	0	1
-94dB	1	0	1	1	1	1	1	0
-95dB	1	0	1	1	1	1	1	1
-96dB	1	1	0	0	0	0	0	0
-97dB	1	1	0	0	0	0	0	1
-98dB	1	1	0	0	0	0	1	0
-99dB	1	1	0	0	0	0	1	1
-∞dB	1	1	1/0	1/0	1	1/0	1/0	1/0

Note: No guarantee except for these codes.

Electrical Characteristics

Unless otherwise noted, Ta = 25°C, AVCC = 7V, AVEE = -7V, DVDD = 5V, f = 1kHz, Volume = 0dB, Input Selector = IN1, Gain Control = 0dB, ADC Input ATT = 0dB, Tone = Bypass

(1) Power supply characteristics

Parameter	Symbol	Limits			Unit	Test condition
		Min	Typ	Max		
Analog positive power circuit current	Alcc	—	32	42	mA	With AVCC = 7V and AVEE = -7V 38pin current, when no signal is provided
Analog negative power circuit current	Alee	-42	-32	—	mA	With AVCC = 7V and AVEE = -7V 37pin current, when no signal is provided
Digital power circuit current	Dldd	—	2	3	mA	With DVDD = 3.3V, 13pin current, when no signal is provided

(2) Input/Output characteristics (OVER ALL)

Parameter	Symbol	Limits			Unit	Test condition
		Min	Typ	Max		
Input resistance	Rin	17	25	33	Ω	2 to 7, 26, 27 pin
Maximum output voltage	VOM	3.8	4.4	—	Vrms	2 to 7pin input, 9 to 12,17,18pin output, THD = 1%, RL = 10k Ω , Output Gain Control = +6dB
Pass gain	Gv	-2.0	0	2.0	dB	2 to 7,26,27 pin input, 9 to 12,17,18pin output, Vi = 0.3Vrms, FLAT
Total harmonic distortion	THD1	—	0.002	0.008	%	2 to 7pin input, 9 to 12, 17,18 pin output, BW: 400Hz to 30kHz, f = 1kHz, Vo = 0.3Vrms, RL=10k Ω
	THD2	—	0.01	0.1		2 to 7pin input, 9 to 12, 17,18pin output, BW: 400Hz to 30kHz, f = 1kHz, Vo = 2Vrms, RL = 10k Ω
Balance of mutual channels	CBAL	-0.5	0	0.5	dB	26,27pin input, 17,18pin output, Vi = 0.3Vrms
Output noise voltage	Vono1	—	1	3	μ Vrms	JIS-A, Rg = 0 Ω , 17,18pin output, Output Gain Control = 0dB
		—	5	15		Volume = - ∞ dB setting Output Gain Control = +12dB
	Vono2	—	1.5	4.5	JIS-A, Rg = 0 Ω , 17,18pin output, Output Gain Control = 0dB	
		—	7.2	22	Volume = 0dB setting Output Gain Control = +12dB	
Vono3	—	1	3	JIS-A, Rg = 0 Ω , 9 to 12pin output, Output Gain Control = 0dB		
	—	5	15	Volume = 0dB setting Output Gain Control = +12dB		
Selector separation	SS1	—	-90	-70	dB	< Input Selector > Vo = 1Vrms, Rg = 0 Ω , RL = 10k Ω , JIS-A
	SS2	—	-90	-70		< Multi Input Selector > Vo = 1Vrms, Rg = 0 Ω , RL = 10k Ω , JIS-A
Channel separation	CS	—	-90	-70		Vo = 1Vrms, Rg = 0 Ω , RL = 10k Ω , JIS-A

(3) 6 channel Volume characteristics

Parameter	Symbol	Limits			Unit	Test condition
		Min	Typ	Max		
Maximum attenuation	ATTmax	—	-100	-95	dB	Vi = 2Vrms, JIS-A, VOL = - ∞ dB
Volume gain gang error of mutual channels	Dvol	-0.5	0	+0.5	dB	Volume = 0dB

(4) Tone control characteristics

Unless otherwise noted, Tone ON/OFF = ON

Parameter	Symbol	Limits			Unit	Test condition
		Min	Typ	Max		
Tone control voltage gain (Boost/Bass)	G (BASS) B	+12	+14	+16	dB	f = 100Hz Bass +14dB setting
Tone control voltage gain (Cut/Bass)	G (BASS) C	-16	-14	-12	dB	f = 100Hz Bass -14dB setting
Tone control voltage gain (Boost/Treble)	G (TRE) B	+12	+14	+16	dB	f = 10kHz Treble +14dB setting
Tone control voltage gain (Cut/Treble)	G (TRE) C	-16	-14	-12	dB	f = 10kHz Treble -10dB setting
Balance of mutual channels	BALT	-2	0	+2	dB	Bass setting +14, -14dB Treble setting +14, -14dB

Tone Control

(1) Bass

< Boost >

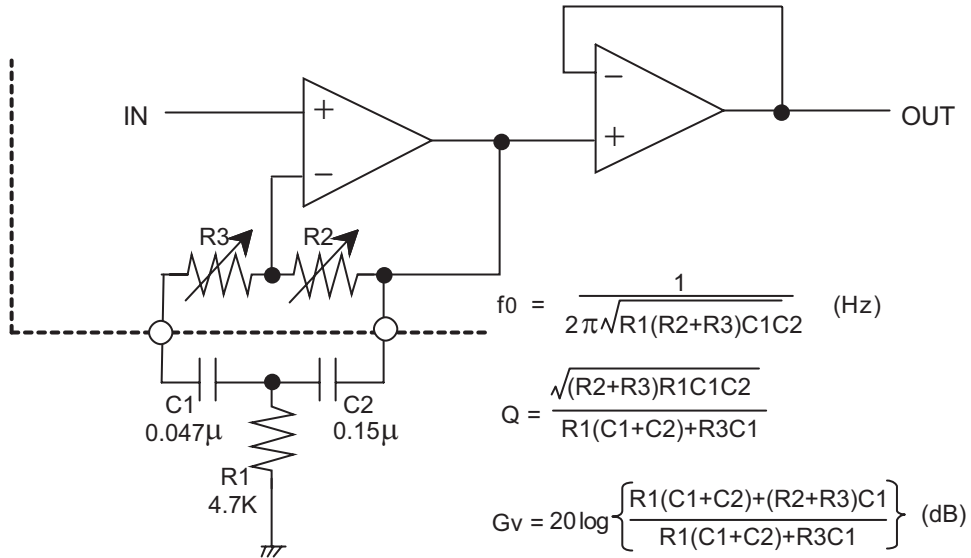

< Cut >

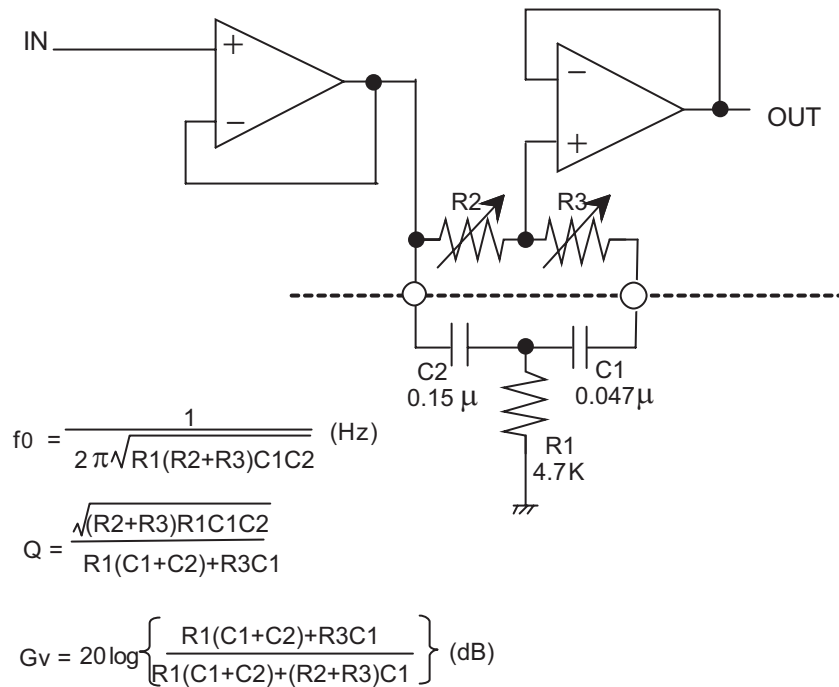

(2) Treble

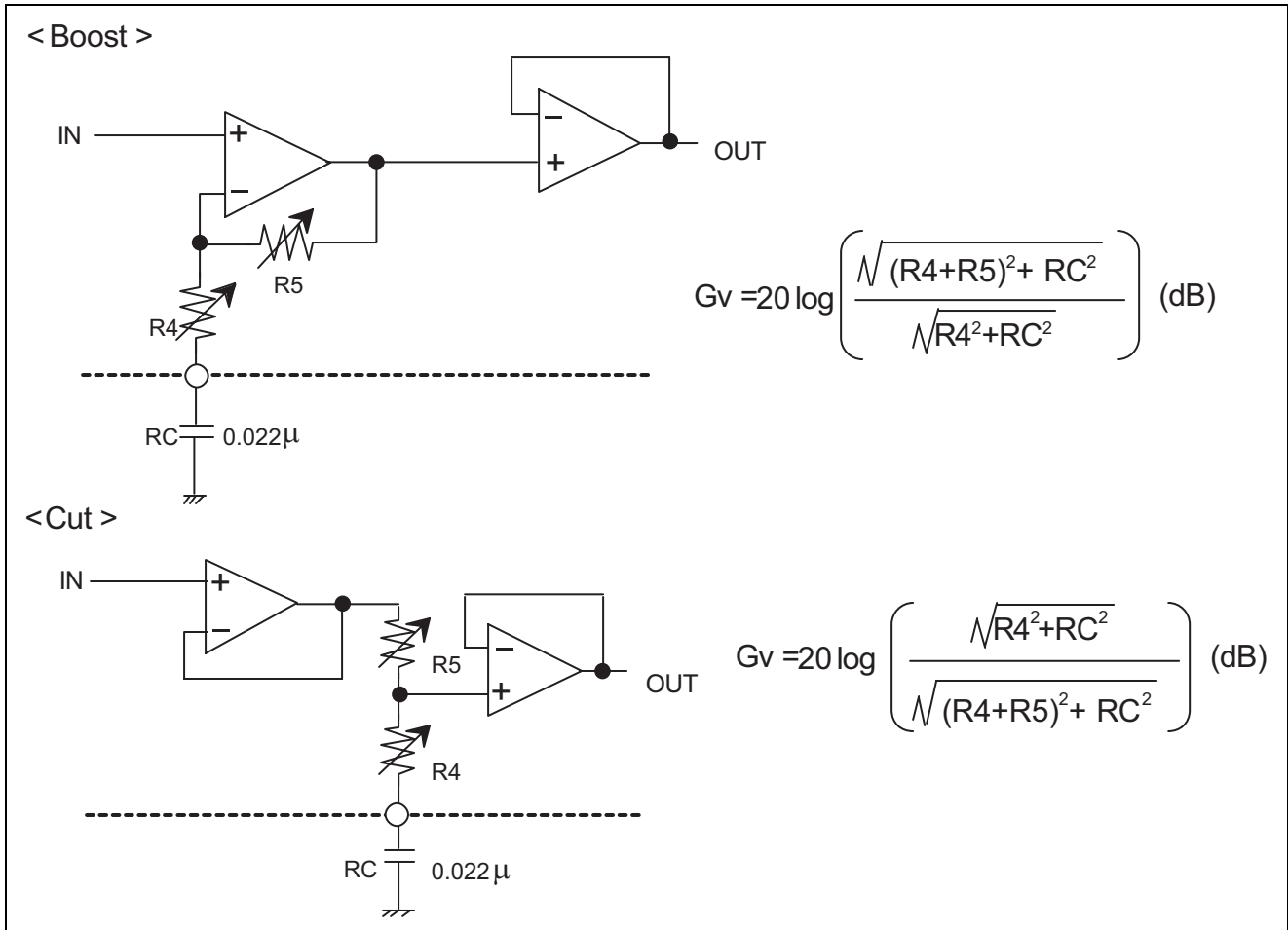

Curve of characteristics

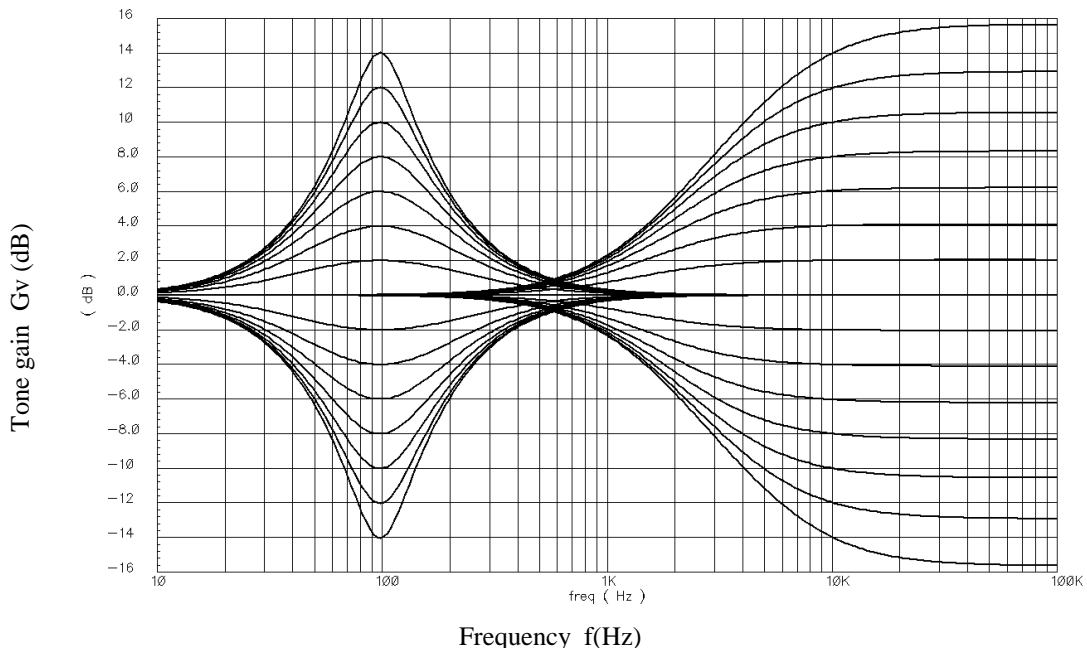

Application Example

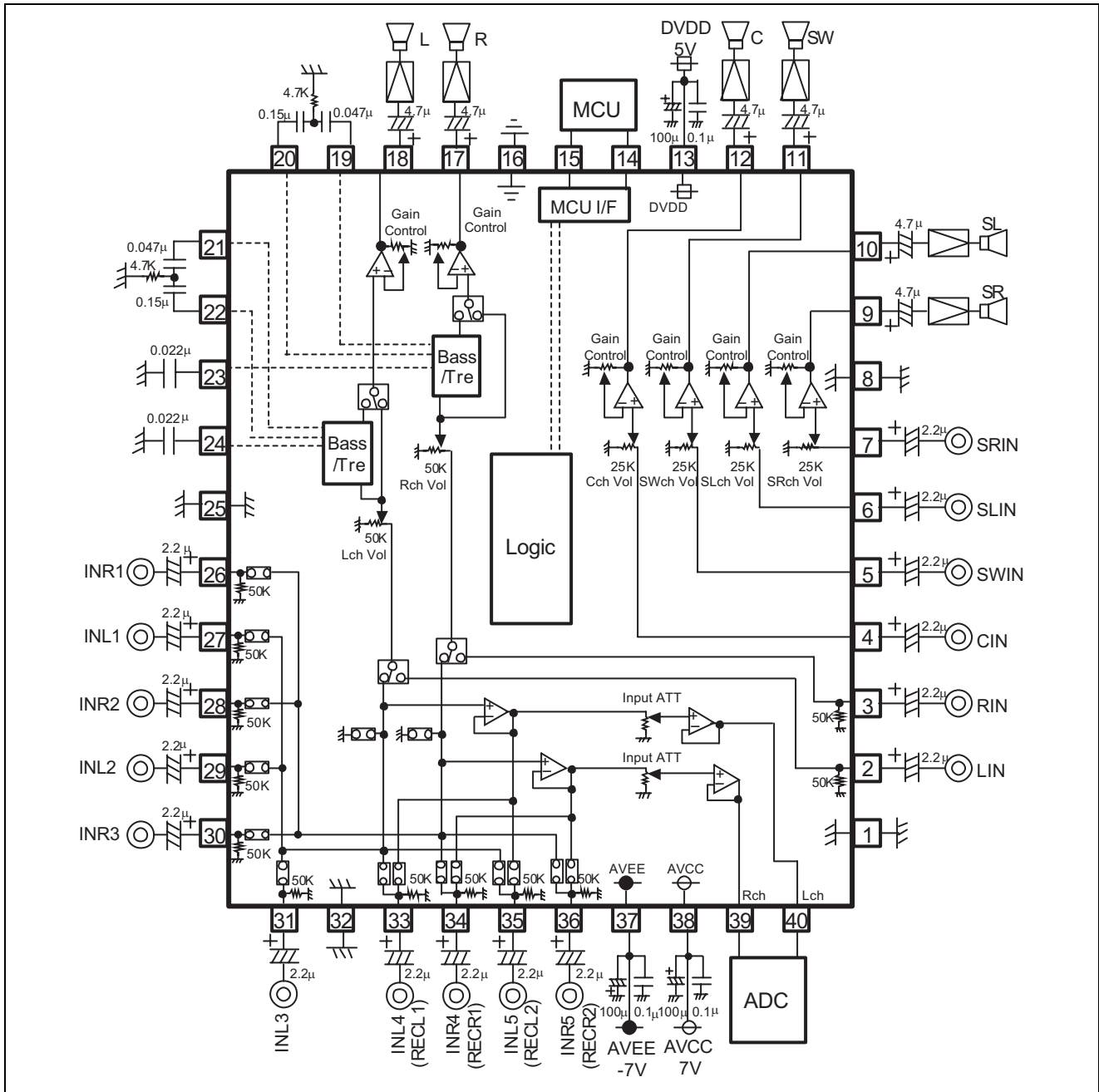

Package Dimensions

As of January, 2003
Unit: mm

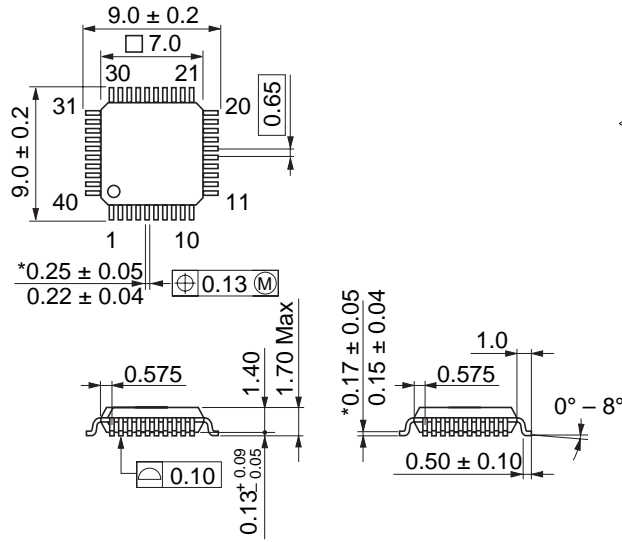

*Dimension including the plating thickness
Base material dimension

Package Code	FP-40B
JEDEC	—
JEITA	Conforms
Mass(reference value)	0.2 g

Renesas Technology Corp. Sales Strategic Planning Div. Nippon Bldg., 2-6-2, Ohte-machi, Chiyoda-ku, Tokyo 100-0004, Japan

Keep safety first in your circuit designs!

1. Renesas Technology Corp. puts the maximum effort into making semiconductor products better and more reliable, but there is always the possibility that trouble may occur with them. Trouble with semiconductors may lead to personal injury, fire or property damage. Remember to give due consideration to safety when making your circuit designs, with appropriate measures such as (i) placement of substitutive, auxiliary circuits, (ii) use of nonflammable material or (iii) prevention against any malfunction or mishap.

Notes regarding these materials

1. These materials are intended as a reference to assist our customers in the selection of the Renesas Technology Corp. product best suited to the customer's application; they do not convey any license under any intellectual property rights, or any other rights, belonging to Renesas Technology Corp. or a third party.
 2. Renesas Technology Corp. assumes no responsibility for any damage, or infringement of any third-party's rights, originating in the use of any product data, diagrams, charts, programs, algorithms, or circuit application examples contained in these materials.
 3. All information contained in these materials, including product data, diagrams, charts, programs and algorithms represents information on products at the time of publication of these materials, and are subject to change by Renesas Technology Corp. without notice due to product improvements or other reasons. It is therefore recommended that customers contact Renesas Technology Corp. or an authorized Renesas Technology Corp. product distributor for the latest product information before purchasing a product listed herein.
The information described here may contain technical inaccuracies or typographical errors.
Renesas Technology Corp. assumes no responsibility for any damage, liability, or other loss rising from these inaccuracies or errors.
Please also pay attention to information published by Renesas Technology Corp. by various means, including the Renesas Technology Corp. Semiconductor home page (<http://www.renesas.com>).
 4. When using any or all of the information contained in these materials, including product data, diagrams, charts, programs, and algorithms, please be sure to evaluate all information as a total system before making a final decision on the applicability of the information and products. Renesas Technology Corp. assumes no responsibility for any damage, liability or other loss resulting from the information contained herein.
 5. Renesas Technology Corp. semiconductors are not designed or manufactured for use in a device or system that is used under circumstances in which human life is potentially at stake. Please contact Renesas Technology Corp. or an authorized Renesas Technology Corp. product distributor when considering the use of a product contained herein for any specific purposes, such as apparatus or systems for transportation, vehicular, medical, aerospace, nuclear, or undersea repeater use.
 6. The prior written approval of Renesas Technology Corp. is necessary to reprint or reproduce in whole or in part these materials.
 7. If these products or technologies are subject to the Japanese export control restrictions, they must be exported under a license from the Japanese government and cannot be imported into a country other than the approved destination.
Any diversion or reexport contrary to the export control laws and regulations of Japan and/or the country of destination is prohibited.
 8. Please contact Renesas Technology Corp. for further details on these materials or the products contained therein.
-



RENESAS SALES OFFICES

<http://www.renesas.com>

Renesas Technology America, Inc.
450 Holger Way, San Jose, CA 95134-1368, U.S.A
Tel: <1> (408) 382-7500 Fax: <1> (408) 382-7501

Renesas Technology Europe Limited.
Dukes Meadow, Millboard Road, Bourne End, Buckinghamshire, SL8 5FH, United Kingdom
Tel: <44> (1628) 585 100, Fax: <44> (1628) 585 900

Renesas Technology Europe GmbH
Dornacher Str. 3, D-85622 Feldkirchen, Germany
Tel: <49> (89) 380 70 0, Fax: <49> (89) 929 30 11

Renesas Technology Hong Kong Ltd.
7/F., North Tower, World Finance Centre, Harbour City, Canton Road, Hong Kong
Tel: <852> 2265-6688, Fax: <852> 2375-6836

Renesas Technology Taiwan Co., Ltd.
FL 10, #99, Fu-Hsing N. Rd., Taipei, Taiwan
Tel: <886> (2) 2715-2888, Fax: <886> (2) 2713-2999

Renesas Technology (Shanghai) Co., Ltd.
26/F., Ruijin Building, No.205 Maoming Road (S), Shanghai 200020, China
Tel: <86> (21) 6472-1001, Fax: <86> (21) 6415-2952

Renesas Technology Singapore Pte. Ltd.
1, Harbour Front Avenue, #06-10, Keppel Bay Tower, Singapore 098632
Tel: <65> 6213-0200, Fax: <65> 6278-8001