

Document Title

256K x16 bit 2.7 ~ 3.3V Super Low Power FCMOS Slow SRAM

Revision History

| <u>Revision No</u> | <u>History</u> | <u>Draft Date</u> | <u>Remark</u> |
|--------------------|--|-------------------|---------------|
| 09 | Marking Information add tBLZ / tOLZ value is changed Output Load is redefined Isb, Isb1, Vdr, Iccdr are redefined | Dec.18.2000 | Final |
| 10 | Changed Logo | Mar.23.2001 | Final |
| 11 | Changed Isb1 values | Jun.07.2001 | Final |

DESCRIPTION

The HY62UF16403A is a high speed, super low power and 4Mbit full CMOS SRAM organized as 256K words by 16bits. The HY62UF16403A uses high performance full CMOS process technology and is designed for high speed and low power circuit technology. It is particularly well-suited for the high density low power system application. This device has a data retention mode that guarantees data to remain valid at a minimum power supply voltage of 1.2V.

FEATURES

- Fully static operation and Tri-state output
- TTL compatible inputs and outputs
- Battery backup
 - 1.2V(min) data retention
- Standard pin configuration
 - 48-ball uBGA

| Product No. | Voltage (V) | Speed (ns) | Operation Current/Icc(mA) | Standby Current(uA) | | Temperature (°C) |
|----------------|-------------|------------|---------------------------|---------------------|----|------------------|
| | | | | LL | SL | |
| HY62UF16403A | 2.7~3.3 | 55/70/85 | 5 | 15 | 6 | 0~70 |
| HY62UF16403A-I | 2.7~3.3 | 55/70/85 | 5 | 15 | 6 | -40~85(I) |

Note 1. Blank : Commercial, I : Industrial
 2. Current value is max.

PIN CONNECTION

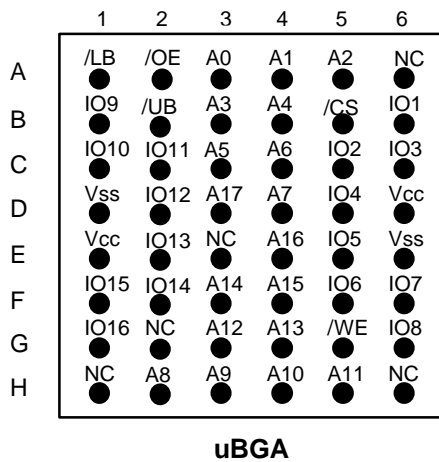

BLOCK DIAGRAM

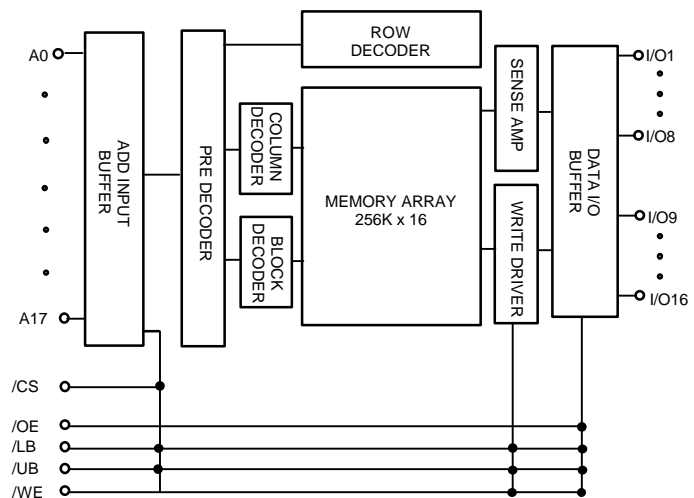

PIN DESCRIPTION

| Pin Name | Pin Function | Pin Name | Pin Function |
|----------|---------------------------------|------------|---------------------|
| /CS | Chip Select | I/O1~I/O16 | Data Inputs/Outputs |
| /WE | Write Enable | A0~A17 | Address Inputs |
| /OE | Output Enable | Vcc | Power (2.7~3.3V) |
| /LB | Lower Byte Control (I/O1~I/O8) | Vss | Ground |
| /UB | Upper Byte Control (I/O9~I/O16) | NC | No Connection |

ORDERING INFORMATION

| Part No. | Speed | Power | Temp | Package |
|-------------------|----------|---------|------|---------|
| HY62UF16403ALLM | 55/70/85 | LL-part | | uBGA |
| HY62UF16403ASLM | 55/70/85 | SL-part | | uBGA |
| HY62UF16403ALLM-I | 55/70/85 | LL-part | I | uBGA |
| HY62UF16403ASLM-I | 55/70/85 | SL-part | I | uBGA |

Note 1. Blank : Commercial, I : Industrial

ABSOLUTE MAXIMUM RATINGS (1)

| Symbol | Parameter | Rating | Unit | Remark |
|------------------------------------|-----------------------------------|-------------|--------|----------------|
| V _{IN} , V _{OUT} | Input/Output Voltage | -0.3 to 3.6 | V | |
| V _{CC} | Power Supply | -0.3 to 4.6 | V | |
| T _A | Operating Temperature | 0 to 70 | °C | HY62UF16403A |
| | | -40 to 85 | °C | HY62UF16403A-I |
| T _{STG} | Storage Temperature | -55 to 150 | °C | |
| P _D | Power Dissipation | 1.0 | W | |
| T _{SOLDER} | Ball Soldering Temperature & Time | 260 • 10 | °C•sec | |

Note

- Stresses greater than those listed under ABSOLUTE MAXIMUM RATINGS may cause permanent damage to the device. This is stress rating only and the functional operation of the device under these or any other conditions above those indicated in the operation of this specification is not implied. Exposure to the absolute maximum rating conditions for extended period may affect reliability.

TRUTH TABLE

| /CS | /WE | /OE | /LB | /UB | Mode | I/O Pin | | Power |
|-----|-----|-----|-----|-----|-----------------|-----------|------------|---------|
| | | | | | | I/O1~I/O8 | I/O9~I/O16 | |
| H | X | X | X | X | Deselected | High-Z | High-Z | Standby |
| X | X | X | H | H | | | | |
| L | H | H | L | X | Output Disabled | High-Z | High-Z | Active |
| | | | X | L | | | | |
| L | H | L | L | H | Read | DOUT | High-Z | Active |
| | | | H | L | | High-Z | DOUT | |
| | | | L | L | | DOUT | DOUT | |
| L | L | X | L | H | Write | DIN | High-Z | Active |
| | | | H | L | | High-Z | DIN | |
| | | | L | L | | DIN | DIN | |

Note:

- H=V_{IH}, L=V_{IL}, X=don't care (V_{IL} or V_{IH})
- /UB, /LB(Upper, Lower Byte enable)
 These active LOW inputs allow individual bytes to be written or read.
 When /LB is LOW, data is written or read to the lower byte, I/O 1 -I/O 8.
 When /UB is LOW, data is written or read to the upper byte, I/O 9 -I/O 16.

RECOMMENDED DC OPERATING CONDITION

| Symbol | Parameter | Min. | Typ | Max. | Unit |
|-----------------|--------------------|-------------------|-----|----------------------|------|
| Vcc | Supply Voltage | 2.7 | 3.0 | 3.3 | V |
| Vss | Ground | 0 | 0 | 0 | V |
| V _{IH} | Input High Voltage | 2.2 | - | V _{cc} +0.3 | V |
| V _{IL} | Input Low Voltage | -0.3 ¹ | - | 0.6 | V |

Note : 1. Undershoot : V_{IL} = -1.5V for pulse width less than 30ns
 2. Undershoot is sampled, not 100% tested.

DC ELECTRICAL CHARACTERISTICS

T_A = 0°C to 70°C / -40°C to 85°C (I)

| Sym | Parameter | Test Condition | Min | Typ ¹ | Max | Unit |
|------------------|--------------------------------|---|-----|------------------|-----|------|
| I _{LI} | Input Leakage Current | V _{ss} ≤ V _{IN} ≤ V _{cc} | -1 | - | 1 | uA |
| I _{LO} | Output Leakage Current | V _{ss} ≤ V _{OUT} ≤ V _{cc} , /CS = V _{IH} or /OE = V _{IH} or /WE = V _{IL} or /UB = V _{IH} , /LB = V _{IH} | -1 | - | 1 | uA |
| I _{cc} | Operating Power Supply Current | /CS = V _{IL} , V _{IN} = V _{IH} or V _{IL} , I _{I/O} = 0mA | | | 5 | mA |
| I _{CC1} | Average Operating Current | /CS = V _{IL} , V _{IN} = V _{IH} or V _{IL} , Cycle Time = Min, 100% Duty, I _{I/O} = 0mA | | | 50 | mA |
| | | /CS ≤ 0.2V, V _{IN} ≤ 0.2V or V _{IN} ≥ V _{cc} -0.2V, Cycle Time = 1us, 100% Duty, I _{I/O} = 0mA | | | 5 | mA |
| I _{SB} | Standby Current (TTL Input) | /CS = V _{IH} or /UB, /LB = V _{IH} V _{IN} = V _{IH} or V _{IL} | | | 0.5 | mA |
| I _{SB1} | Standby Current (CMOS Input) | /CS ≥ V _{cc} - 0.2V or /UB, /LB ≥ V _{cc} - 0.2V V _{IN} ≥ V _{cc} - 0.2V or V _{IN} ≤ V _{ss} + 0.2V | SL | 0.2 | 6 | uA |
| | | | LL | 0.2 | 15 | uA |
| V _{OL} | Output Low | I _{OL} = 2.1mA | - | - | 0.4 | V |
| V _{OH} | Output High | I _{OH} = -1.0mA | 2.4 | - | - | V |

Note

1. Typical values are at V_{cc} = 3.0V T_A = 25°C
2. Typical values are not 100% tested

CAPACITANCE

(Temp = 25°C, f= 1.0MHz)

| Symbol | Parameter | Condition | Max. | Unit |
|------------------|---|-----------------------|------|------|
| C _{IN} | Input Capacitance(Add, /CS, /LB, /UB, /WE, /OE) | V _{IN} = 0V | 8 | pF |
| C _{OUT} | Output Capacitance(I/O) | V _{I/O} = 0V | 10 | pF |

Note : These parameters are sampled and not 100% tested

AC CHARACTERISTICS

TA = 0°C to 70°C / -40°C to 85°C (I), unless otherwise specified

| # | Symbol | Parameter | 55ns | | 70ns | | 85ns | | Unit |
|-------------|--------|--------------------------------------|------|------|------|------|------|------|------|
| | | | Min. | Max. | Min. | Max. | Min | Max. | |
| READ CYCLE | | | | | | | | | |
| 1 | tRC | Read Cycle Time | 55 | - | 70 | - | 85 | - | ns |
| 2 | tAA | Address Access Time | - | 55 | - | 70 | - | 85 | ns |
| 3 | tACS | Chip Select Access Time | - | 55 | - | 70 | - | 85 | ns |
| 4 | tOE | Output Enable to Output Valid | - | 30 | - | 35 | - | 40 | ns |
| 5 | tBA | /LB, /UB Access Time | - | 55 | - | 70 | - | 85 | ns |
| 6 | tCLZ | Chip Select to Output in Low Z | 10 | - | 10 | - | 10 | - | ns |
| 7 | tOLZ | Output Enable to Output in Low Z | 5 | - | 5 | - | 5 | - | ns |
| 8 | tBLZ | /LB, /UB Enable to Output in Low Z | 10 | - | 10 | - | 10 | - | ns |
| 9 | tCHZ | Chip Deselection to Output in High Z | 0 | 30 | 0 | 30 | 0 | 30 | ns |
| 10 | tOHZ | Out Disable to Output in High Z | 0 | 30 | 0 | 30 | 0 | 30 | ns |
| 11 | tBHZ | /LB, /UB Disable to Output in High Z | 0 | 30 | 0 | 30 | 0 | 30 | ns |
| 12 | tOH | Output Hold from Address Change | 10 | - | 10 | - | 10 | - | ns |
| WRITE CYCLE | | | | | | | | | |
| 13 | tWC | Write Cycle Time | 55 | - | 70 | - | 85 | - | ns |
| 14 | tCW | Chip Selection to End of Write | 50 | - | 60 | - | 70 | - | ns |
| 15 | tAW | Address Valid to End of Write | 50 | - | 60 | - | 70 | - | ns |
| 16 | tBW | /LB, /UB Valid to End of Write | 50 | - | 60 | - | 70 | - | ns |
| 17 | tAS | Address Set-up Time | 0 | - | 0 | - | 0 | - | ns |
| 18 | tWP | Write Pulse Width | 45 | - | 50 | - | 60 | - | ns |
| 19 | tWR | Write Recovery Time | 0 | - | 0 | - | 0 | - | ns |
| 20 | tWHZ | Write to Output in High Z | 0 | 20 | 0 | 20 | 0 | 25 | ns |
| 21 | tDW | Data to Write Time Overlap | 25 | - | 30 | - | 35 | - | ns |
| 22 | tDH | Data Hold from Write Time | 0 | - | 0 | - | 0 | - | ns |
| 23 | tOW | Output Active from End of Write | 5 | - | 5 | - | 5 | - | ns |

AC TEST CONDITIONS

TA = 0°C to 70°C / -40°C to 85°C (I), unless otherwise specified

| Parameter | | Value |
|---|---|-----------------------|
| Input Pulse Level | | 0.4V to 2.2V |
| Input Rise and Fall Time | | 5ns |
| Input and Output Timing Reference Level | | 1.5V |
| Output Load | tCLZ, tOLZ, tBLZ, tCHZ, tOHZ, tBHZ, tWHZ, tOW | CL = 5pF + 1TTL Load |
| | Others | CL = 30pF + 1TTL Load |

AC TEST LOADS

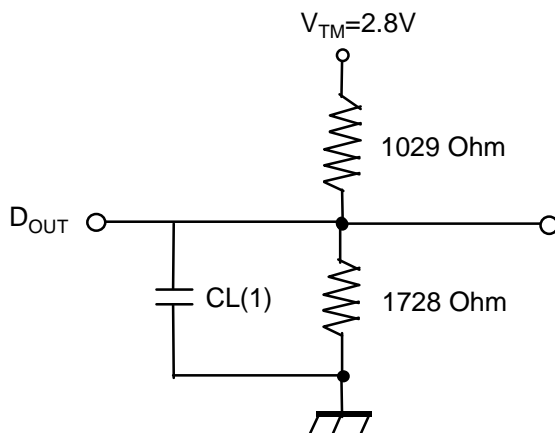

Note 1. Including jig and scope capacitance.

TIMING DIAGRAM

READ CYCLE 1 (Note 1,4)

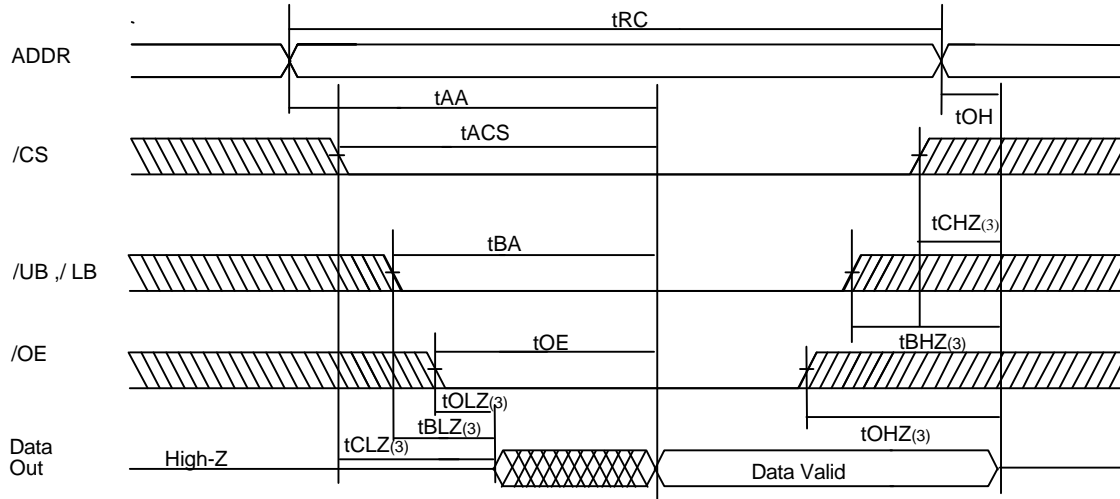

READ CYCLE 2 (Note 1,2,4)

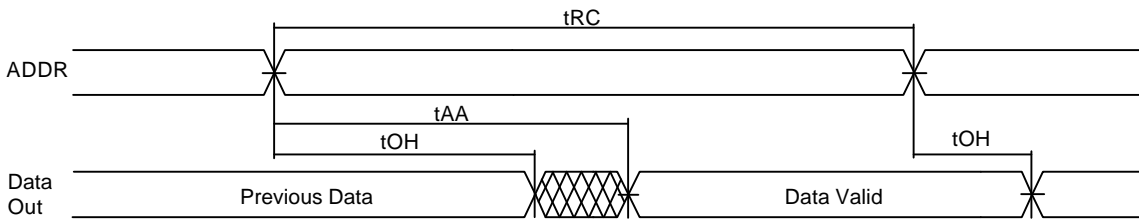

READ CYCLE 3 (Note 1,2,4)

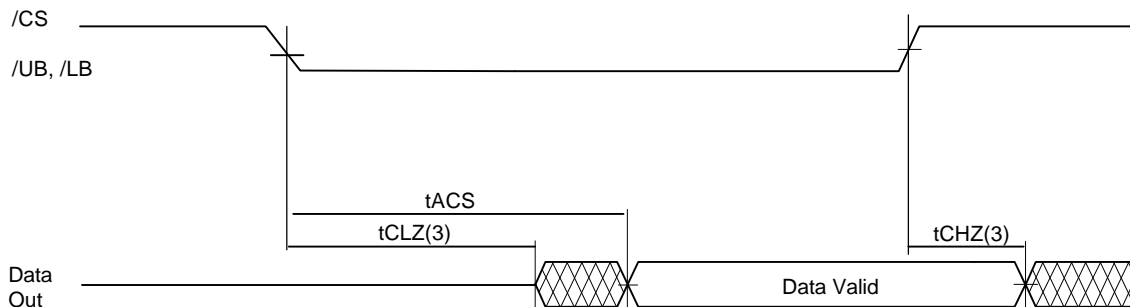

Notes:

1. A read occurs during the overlap of a low /OE, a high /WE, a low /CS and /UB and/or /LB .
2. /OE = V_{IL}
3. Transition is measured ± 200mV from steady state voltage.
This parameter is sampled and not 100% tested.
4. /CS in high for the standby, low for active
/UB and /LB in high for the standby, low for active

WRITE CYCLE 1 (1,4,8) (/WE Controlled)

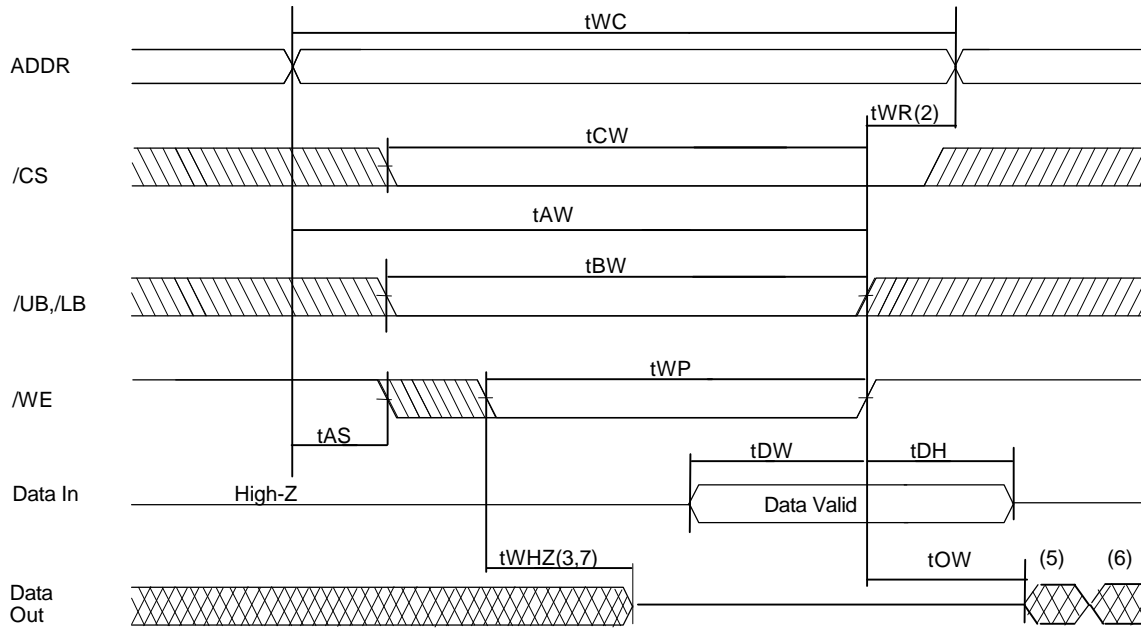

WRITE CYCLE 2 (Note 1,4,8) (/CS Controlled)

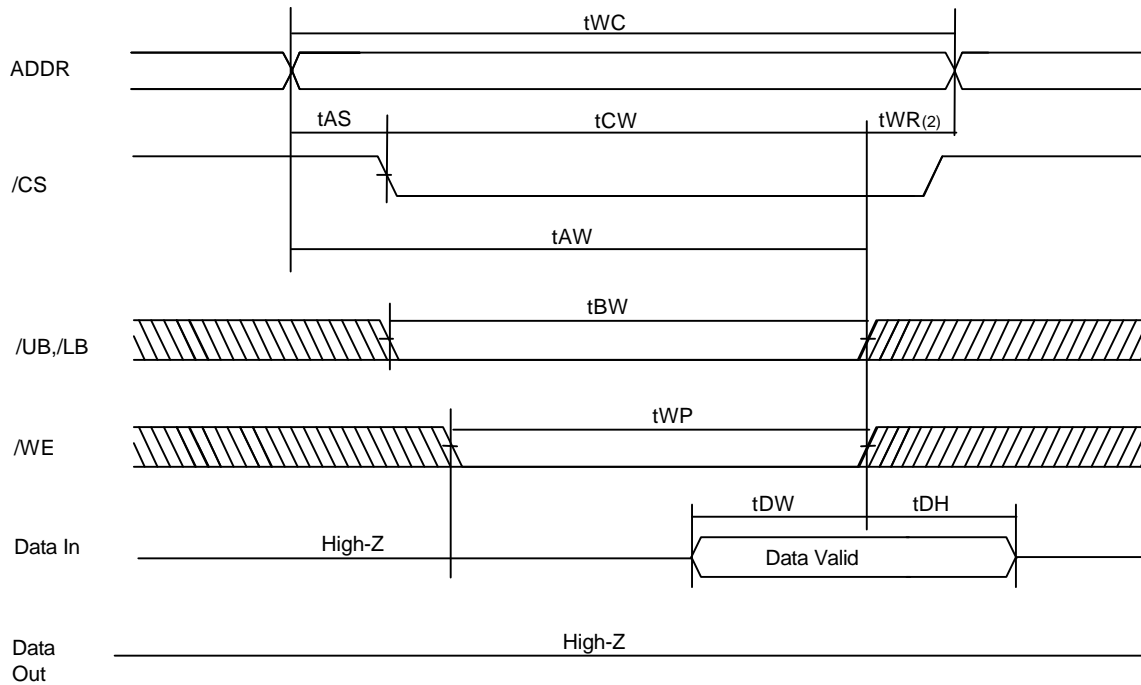

Notes:

1. A write occurs during the overlap of a low /WE, a low /CS and a low /UB and/or /LB .
2. tWR is measured from the earlier of /CS, /LB, /UB, or /WE going high to the end of write cycle.
3. During this period, I/O pins are in the output state so that the input signals of opposite phase to the output must not be applied.
4. If the /CS, /LB and /UB low transition occur simultaneously with the /WE low transition or after the /WE transition, outputs remain in a high impedance state.
5. Q(data out) is the same phase with the write data of this write cycle.
6. Q(data out) is the read data of the next address.
7. Transition is measured $\pm 200\text{mV}$ from steady state.
This parameter is sampled and not 100% tested.
8. /CS in high for the standby, low for active
/UB and /LB in high for the standby, low for active

DATA RETENTION ELECTRIC CHARACTERISTIC

TA=0°C to 70°C /-40°C to 85°C (I)

| Symbol | Parameter | Test Condition | Min | Typ ¹ | Max | Unit | |
|--------|--------------------------------------|--|-----|------------------|-----|------|---------------|
| VDR | Vcc for Data Retention | /CS \geq Vcc - 0.2V or /UB, /LB \geq Vcc - 0.2V, VIN \geq Vcc - 0.2V or VIN \leq Vss + 0.2V | 1.2 | - | 3.3 | V | |
| Iccdr | Data Retention Current | Vcc=1.5V, /CS \geq Vcc - 0.2V or /UB, /LB \geq Vcc - 0.2V VIN \geq Vcc - 0.2V or VIN \leq Vss + 0.2V | SL | - | 0.1 | 3 | μA |
| | | | LL | - | 0.1 | 10 | μA |
| tCDR | Chip Deselect to Data Retention Time | See Data Retention Timing Diagram | 0 | - | - | ns | |
| tR | Operating Recovery Time | | tRC | - | - | ns | |

Notes:

1. Typical values are under the condition of TA = 25°C.
2. Typical value are sampled and not 100% tested

DATA RETENTION TIMING DIAGRAM

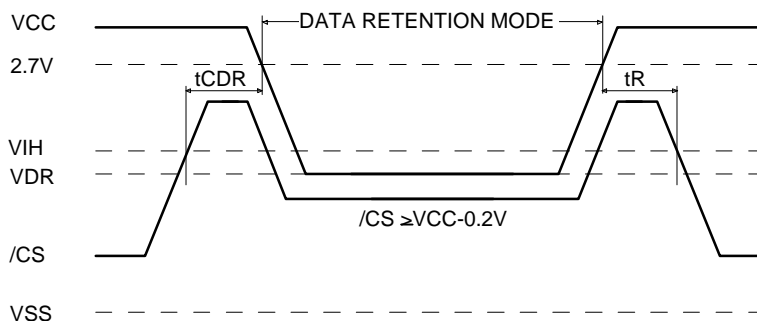

PACKAGE INFORMATION

48ball Micro Ball Grid Array Package(M)

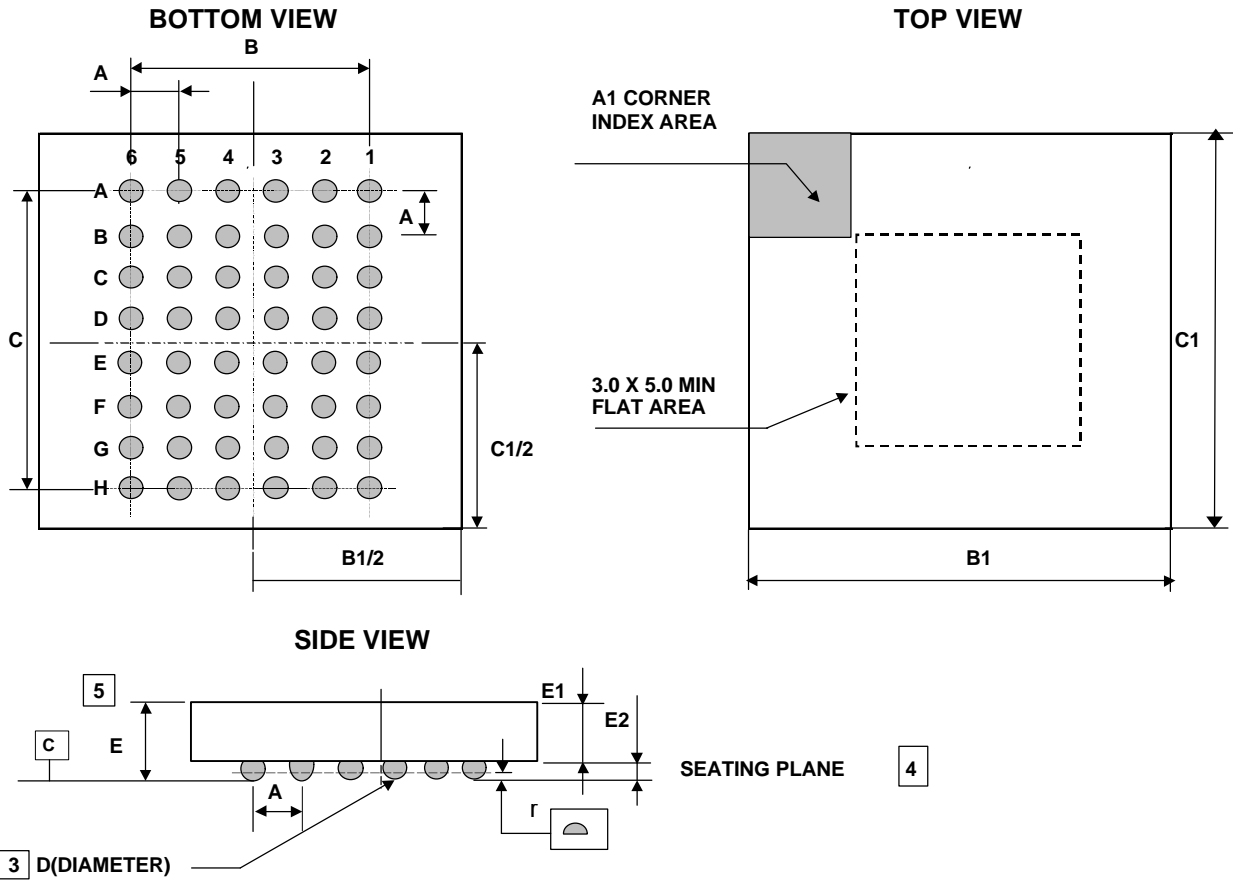

| Symbol | Min. | Typ. | Max. |
|--------|------|------|------|
| A | - | 0.75 | - |
| B | - | 3.75 | - |
| B1 | 8.3 | 8.4 | 8.5 |
| C | - | 5.25 | - |
| C1 | 7.1 | 7.2 | 7.3 |
| D | 0.3 | 0.35 | 0.4 |
| E | 0.85 | 0.9 | 0.95 |
| E1 | 0.6 | 0.65 | 0.7 |
| E2 | 0.2 | 0.25 | 0.3 |
| r | - | - | 0.08 |

Note

1. DIMENSIONING AND TOLERANCING PER ASME Y14. 5M-1994.
2. ALL DIMENSIONS ARE MILLIMETERS.
3. DIMENSION "D" IS MEASURED AT THE MAXIMUM SOLDER BALL DIAMETER IN A PLANE PARALLEL TO DATUM C.
4. PRIMARY DATUM C(SEATING PLANE) IS DEFINED BY THE CROWN OF THE SOLDER BALLS.
5. THIS IS A CONTROLLING DIMENSION.

MARKING INFORMATION

| Package | Marking Example |
|-------------|-----------------|
| <p>uBGA</p> | |

Index

| | |
|-------------------|---|
| • HYUF643A | : Part Name |
| • c | : Power Consumption |
| | - L : Low Low Power |
| | - S : Super Low Power |
| • ss | : Speed |
| | - 55 : 55ns |
| | - 70 : 70ns |
| | - 85 : 85ns |
| • t | : Temperature |
| | - C : Industrial (-0 ~ 70 °C) |
| | - I : Industrial (-40 ~ 85 °C) |
| • yy | : Year (ex : 00 = year 2000, 01= year 2001) |
| • ww | : Work Week (ex : 12 = work week 12) |
| • p | : Process Code |
| • xxxxx | : Lot No. |
| • KOR | : Origin Country |
| Note | |
| - Capital Letter | : Fixed Item |
| - Small Letter | : Non-fixed Item |