



HIC for 2-Phase Stepping Motor

PMM2301

Micro Step

Outline

The Stepping motor driver IC “PMM2301” is a power hybrid IC (HIC) packaging the integrated excitation mode generation circuits and related switching elements for 2-phase stepping motor driving.

This product is developed for the purpose to further simplify 2-phase stepping motor use, as combined only with a few peripheral parts to configure a 2-phase stepping motor driver.

Characteristics

- Sine wave driven micro-step driver.
- The current detection resistor is incorporated.
- MOSFET is used for the power driving circuit to reduce heating.
- Totally packaged to reduce parts for the peripheral circuit.
- Enables selection from the 5 various excitation modes by the external bit signal.

Maximum Rating (T_c=25°C)

Item	Symbol	Condition	Rated value	Unit
Source voltage -1	V _{CC1 max}	V _{CC2} =0V	52	V
Source voltage -2	V _{CC2 max}	with no signal	7	V
Input voltage	V _{in max}	Logic input terminal	7	V
Phase current	I _{OH max}	0.5sec, 1pulse, V _{CC1} applied	4	A
Operating temperature on PCB	T _{C max}	–	105	°C
Junction temperature	T _{J max}	–	150	°C
Conservation temperature	T _{stg}	–	–40~125	°C

Recommended Operating Conditions (T_a=25°C)

Item	Symbol	Condition	Rated value	Unit
Source voltage -1	V _{CC1}	with signal	10~45	V
Source voltage -2	V _{CC2}	with signal	5.0±5%	V
Input voltage	V _{IH}	–	0~V _{CC2}	V
Phase current	I _{OH}	Duty 50%	3	A
Clock frequency	Clock	–	DC~50	kHz
Withstand voltage of phase driver	V _{DSS}	–	100	V

Dimensions (Unit: mm)

Pin No.	Terminal name
1.	B
2.	B
3.	P.GND A
4.	P.GND B
5.	A
6.	A
7.	V _{CC2}
8.	V _{ref}
9.	Mode 1
10.	Mode 2
11.	Mode 3

Pin No.	Terminal name
12.	V _{CC2}
13.	V _{CC2}
14.	Clock
15.	CW/CCW
16.	Reset
17.	Return
18.	Enable
19.	M ₀₁
20.	M ₀₁
21.	M ₀₂
22.	GND

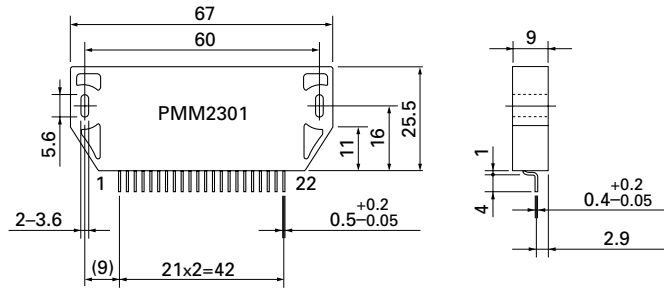

Each Terminal Function

Terminal name	Function	Functioning condition															
V _{ref}	Motor current setting input	-															
Clock	Motor driving pulse input	Mode 3="H" level: Operates at rising edge Mode 3="L" level: Operates at rising and falling edges															
CW/CCW	Motor rotation direction setting input	"H" level= CW rotation "L" level= CCW rotation															
Reset	System reset	Reset="L"															
Return	Forced return to phase origin	Forced shift to the origin of the present energization phase with Return="H".															
Enable	Power OFF input	Enable="L"															
M ₀₁	Phase origin monitor output	"L" level output at the phase origin.															
M ₀₁ , M ₀₂	Monitor output on phase energization status	Outputs level signal on the present phase energization status.															
		<table border="1"> <thead> <tr> <th>Phase coordinate</th> <th>A phase</th> <th>B phase</th> <th>\bar{A} phase</th> <th>\bar{B} phase</th> </tr> </thead> <tbody> <tr> <td>M₀₁</td> <td>H</td> <td>L</td> <td>L</td> <td>H</td> </tr> <tr> <td>M₀₂</td> <td>L</td> <td>H</td> <td>L</td> <td>H</td> </tr> </tbody> </table>	Phase coordinate	A phase	B phase	\bar{A} phase	\bar{B} phase	M ₀₁	H	L	L	H	M ₀₂	L	H	L	H
Phase coordinate	A phase	B phase	\bar{A} phase	\bar{B} phase													
M ₀₁	H	L	L	H													
M ₀₂	L	H	L	H													

Energization Mode Table

Input condition			Energization mode	1 step angle (degree)	Number of basic angle division
Mode 1	Mode 2	Mode 3			
L	L	H	2EX	1.8	1/1
H	L	H	1-2EX	0.9	1/2
L	H	H	W1-2EX	0.45	1/4
H	H	H	2W1-2EX	0.225	1/8
H	H	L	4W1-2EX	0.1125	1/16

- Conditioned on the Mode 3=L, one pulse operation is performed at every rising and falling edge of the clock pulse. Accordingly, the operation becomes unstable if the driving pulse duty ratio deviates from 50%.

Electrical Characteristics (Tc=25°C, Vcc1=24V, Vcc2=5V)

Item	Symbol	Condition	Rating			Unit
			Min.	Standard	Max.	
Vcc2 Power current	Icco	Enable="L"	-	4.5	15	mA
Effective output current	I _{o ave}	Each phase R/L=3.5Ω/3.8mH Vref=0.6V	0.45	0.50	0.55	A
Forward direction voltage of FET diode	V _{df}	I _f =1A	-	1.2	1.8	V
Output saturating voltage	V _{sat}	RL=7.5Ω (I≒3.0A)	-	1.4	2.6	V
"H" level input voltage	V _{IH}	9~11,14~18 pins	4.0	-	-	V
"L" level input voltage	V _{IL}	9~11,14~18 pins	-	-	1.0	V
Input current	I _{IL}	9~11,14~18 pins=GND level Pull-up resistor 20kΩ	125	250	510	μA
Vref input voltage	V _r	8-pin	0	-	Vcc2/2	V
Vref input current	I _r	8-pin	-	1	-	μA
"H" level output voltage	V _{OH}	19~21 pins I=3mA I=-3mA	2.4	-	-	V
"L" level output voltage	V _{OL}	19~21 pins I=3mA I=3mA	-	-	0.4	V
PWM frequency	F _c	-	37	47	57	kHz

Example of Application Circuit

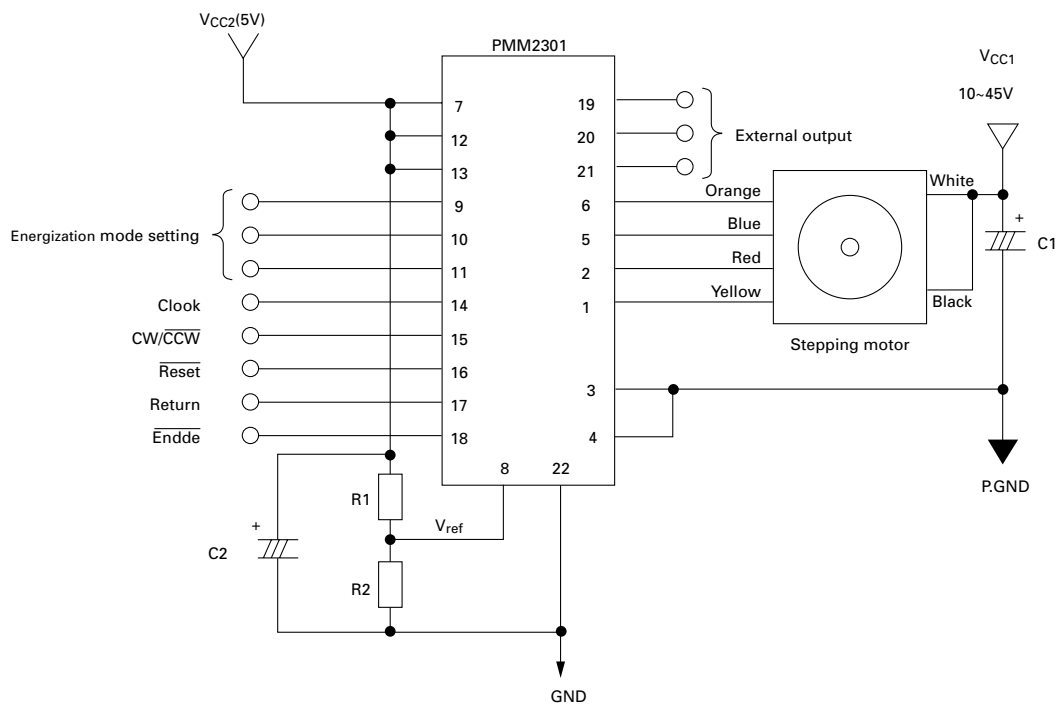

● Recommended circuit constants

C1	C2
100μF OR OVER	10μF

- Determine on the R1 and R2 constants based on the Vref voltage calculated from the following formula.
 $V_{ref}(V) = \text{Motor current adjusted value (A/phase)} \times 0.6$