



defining a degree of excellence

Type MS

Slow Blow Micro Fuse

MSD0199



Electrical Characteristics (UL/CSA STD.248-14)

Testing current	Blow Time	
	Minimum	Maximum
100%	4 Hrs.	N/A
200%	N/A	30 Sec

Approvals



Safety Agency Approvals	Amp range / Volt @ I.R. ability
Recognized File No. E20624	250mA - 7A/125V @ 50A ac; 300A dc.
Certified File No. LR39772	

Catalog Number	Ampere Rating	Typical Cold Resistance (ohm)	Volt-drop @100% In (Volt) max.	Melting I ² T < 10 mSec (A ² Sec)	Melting I ² T @10 In (A ² Sec)	Maximum Power Dissipation (W)
MS 250	250mA	3.20	2.20	0.047	0.042	0.80
MS 300	300mA	2.57	2.02	0.063	0.056	0.82
MS 375	375mA	1.66	1.69	0.111	0.101	0.85
MS 500	500mA	1.07	1.42	0.20	0.18	0.88
MS 750	750mA	0.55	1.09	0.46	0.44	0.94
MS 1	1A	0.36	0.91	0.81	0.78	0.98
MS 1.25	1.25A	0.23	0.77	1.44	1.41	1.01
MS 1.5	1.5A	0.18	0.70	1.9	1.9	1.03
MS 2	2A	0.12	0.59	3.4	3.4	1.08
MS 2.5	2.5A	0.08	0.50	6.0	6.1	1.12
MS 3	3A	0.06	0.45	8.0	8.1	1.14
MS 4	4A	0.04	0.38	14	15	1.19
MS 5	5A	0.02	0.29	33	35	1.26
MS 7	7A	0.01	0.25	59	63	1.31

Consult manufacturer for other ratings

Environmental Specification

Operating Temperature

-55°C to +125°C

Soldering Heat Resistance

260°C, 10 sec. per IEC 68-2-20

Moisture Resistance

MIL-STD-202F, Method 106

Salt Spray

MIL-STD-202, Method 101, Condition B (48Hrs)

Shock Resistance

MIL-STD-202, Method 213, Condition I (Sawtooth)

Vibration Resistance

10-55 Hz x 3 axis/ no load (MIL-STD-202, Method 201)

Physical Specification

Materials

Body:

Molded with UL Recognized epoxy component plastic, UL 94-V0

Lead/Wire:

Tin-lead plated Copper, Diameter 0.032" for all ratings

Marking

On fuse:

"bel", "MS", "Current Rating", "125V" printed in green color

On label:

Above info plus "UL CSA CE" and interrupting rating

Packaging

- In bulk:
1,000 pcs per box
- On Axial Tape & Reel:
2,500 pcs per reel
- Tape & Reel specification:
per EIA-296-E & IEC 286-1
@ 5mm Pitch and 52.4mm inside Tape Spacing

Mechanical Dimensions

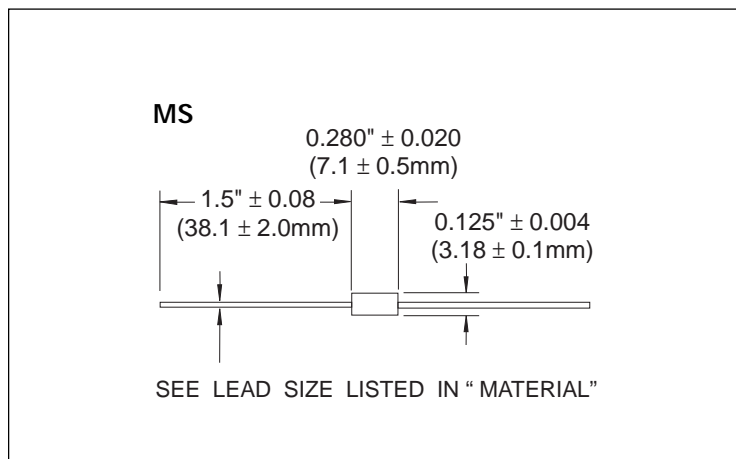

Specifications subject to change without notice

Type MS
Slow Blow Micro Fuse

MS - TIME CURRENT CHARACTERISTIC CURVE

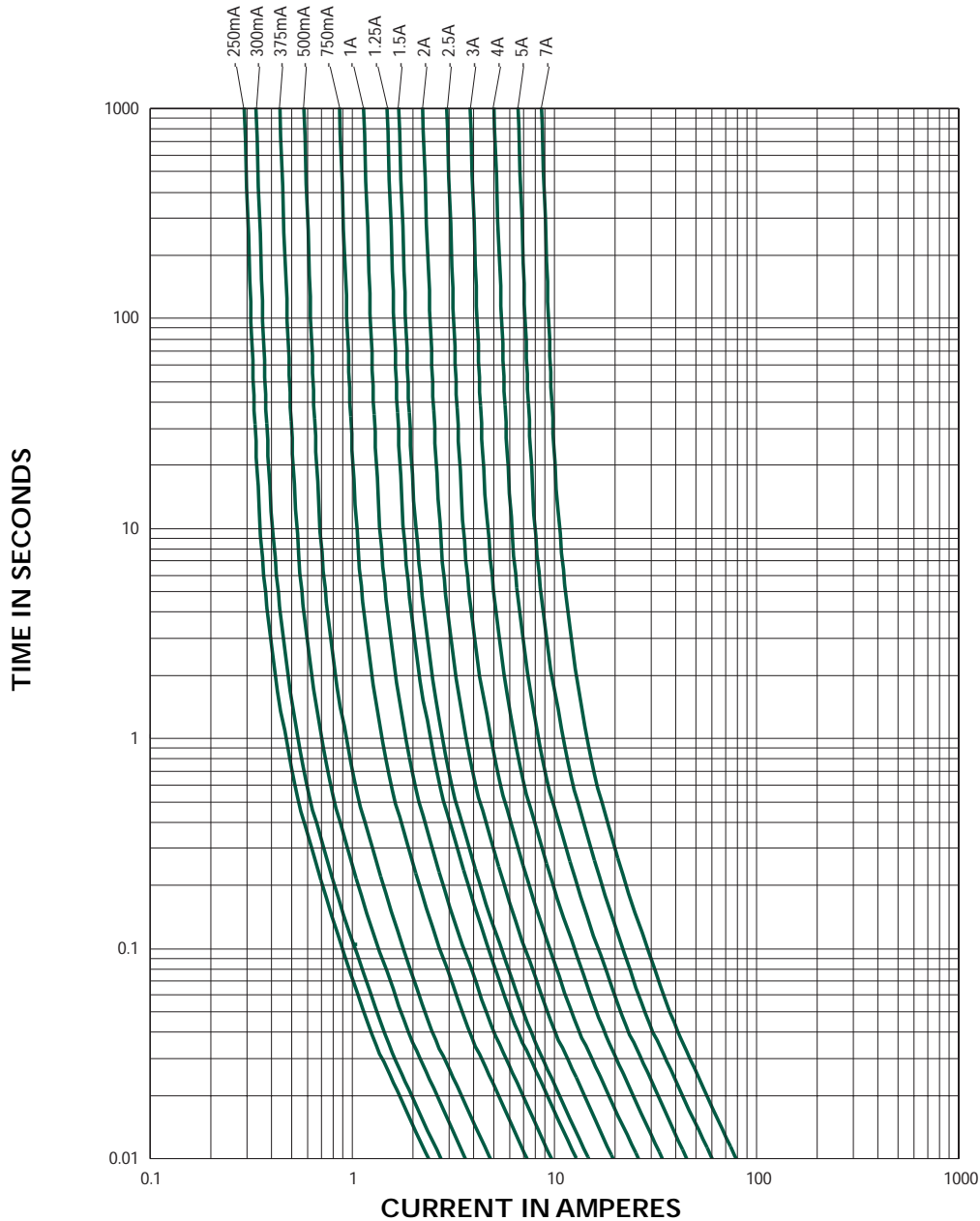

Specifications subject to change without notice

NOTE - see important information under "User Guide" on P.08

Corporate Office

Bel Fuse Inc.
198 Van Vorst Street, Jersey City, NJ 07302
Tel: 201-432-0463
Fax: 201-432-9542
E-Mail: belfuse@belfuse.com
Internet: <http://www.belfuse.com>

Far East Office

Bel Fuse Ltd.
8F/8 Luk Hop Street
San Po Kong
Kowloon, Hong Kong
Tel: 852-2328-5515
Fax: 852-2352-3706

European Office

Bel Fuse Europe Ltd.
Preston Technology Management Centre
Marsh Lane, Preston PR1 8U
Lancashire, U.K.
Tel: 44-1772-556601
Fax: 44-1772-888366