

9097250 TOSHIBA (DISCRETE/OPTO)  
SILICON NPN TRIPLE DIFFUSED TYPE  
(DARLINGTON POWER)

56C 07976 0 T-33-29

**2SD1460**

Unit in mm

HIGH CURRENT SWITCHING APPLICATIONS.

## FEATURES:

- High Collector Current :  $I_C=30A$
- High DC Current Gain :  $h_{FE}=1000(\text{Min.})(V_{CE}=5V, I_C=20A)$
- Monolithic Construction with Built-In Base-Emitter Shunt Resistor.

MAXIMUM RATINGS ( $T_a=25^\circ\text{C}$ )

CHARACTERISTIC	SYMBOL	RATING	UNIT
Collector-Base Voltage	$V_{CBO}$	100	V
Collector-Emitter Voltage	$V_{CEO}$	100	V
Emitter-Base Voltage	$V_{EBO}$	5	V
Collector Current	$I_C$	30	A
Base Current	$I_B$	5	A
Collector Power Dissipation ( $T_c=25^\circ\text{C}$ )	$P_C$	200	W
Junction Temperature	$T_j$	150	$^\circ\text{C}$
Storage Temperature Range	$T_{stg}$	-65 ~ 150	$^\circ\text{C}$

## EQUIVALENT CIRCUIT

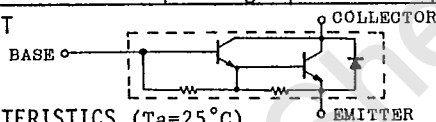
ELECTRICAL CHARACTERISTICS ( $T_a=25^\circ\text{C}$ )

CHARACTERISTIC	SYMBOL	TEST CONDITION	MIN.	TYP.	MAX.	UNIT
Collector Cut-off Current	$I_{CBO}$	$V_{CB}=100V, I_E=0$	-	-	100	$\mu\text{A}$
Emitter Cut-off Current	$I_{EBO}$	$V_{EB}=5V, I_C=0$	-	-	10	mA
Collector-Emitter Breakdown Voltage	$V_{(BR)CEO}$	$I_C=50\text{mA}, I_B=0$	100	-	-	V
DC Current Gain	$h_{FE(1)}$	$V_{CE}=5V, I_C=20A$	1000	-	-	
	$h_{FE(2)}$	$V_{CE}=5V, I_C=30A$	200	-	-	
Collector-Emitter Saturation Voltage	$V_{CE(sat)}$	$I_C=20A, I_B=0.2A$	-	-	1.5	V
Base-Emitter Saturation Voltage	$V_{BE(sat)}$		-	-	2.0	V
Emitter-Collector Forward Voltage	$V_{ECF}$	$I_E=10A, I_B=0$	-	-	3	V
Transition Frequency	$f_T$	$V_{CE}=5V, I_C=1A$	-	10	-	MHz
Collector Output Capacitance	$C_{ob}$	$V_{CB}=10V, I_E=0, f=1\text{MHz}$	-	500	-	pF
Switching Time	Turn on Time	$t_{on}$	-	1.5	-	$\mu\text{s}$
	Storage Time	$t_{stg}$	-	10	-	$\mu\text{s}$
	Fall Time	$t_f$	-	1.5	-	$\mu\text{s}$

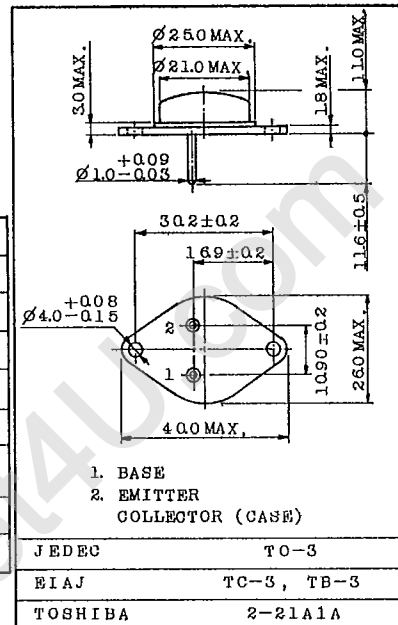

Mounting Kit No. AC73  
Weight : 13g

**2SD1460**

