

# ZXFV201

## QUAD VIDEO AMPLIFIER

### Device Description

The ZXFV201 is a quad, high speed amplifier designed for video and other high speed applications.

It features low differential gain and phase performance. Together with high output drive and slew rate capability, this brings high performance to video applications.

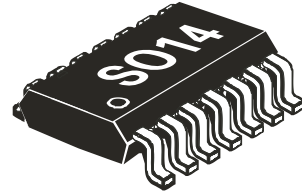

### Features and Benefits

- Unity gain bandwidth 300MHz
- Slew rate 400V/  $\mu$ s
- Differential gain 0.01%
- Differential phase 0.01°
- Output current 40mA
- Characterized up to 300pF load
- $\pm$ 5 Volt supply
- Supply current 7mA per amplifier.
- 14 pin SO package

### Applications

- Video gain stages
- CCTV buffer
- Video distribution
- RGB buffering
- xDSL
- Home theatre
- Fast ADC signal input drive
- High frequency instrumentation
- Cable driving
- Radar imaging
- Medical imaging

### Connection diagram

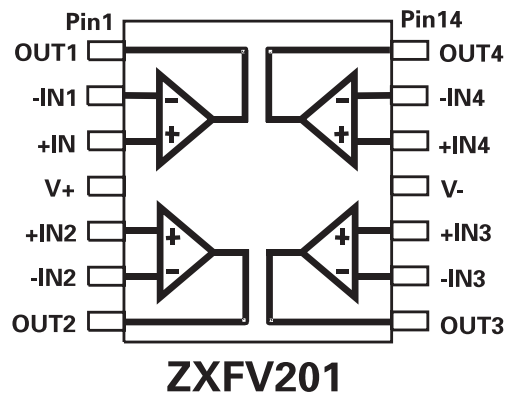

### ORDERING INFORMATION

Part Number	Container	Increment
ZXFV201N14TA	reel 7"	500
ZXFV201N14TC	reel 13"	2500

# ZXFV201

## ABSOLUTE MAXIMUM RATINGS

Supply Voltage, V+ to V-	11V differential ( $\pm 5.5V$ )	
Inputs to ground*	V+ - 0.5V to V- - 0.5V	
Operating Ambient Temperature Range	-40C to 85C	Storage -65C to 150C
Operating Junction Temperature TJMAX**	150°C	

\*\*The thermal resistance from the semiconductor die to ambient is typically 120°C/W when the SO14 package is mounted on a PCB in free air. The power dissipation of the device when loaded must be designed to keep the device junction temperature below TJMAX.

\*During power-up and power-down, these voltage ratings require an appropriate sequence of applying and removing signals and power supplies.

**ESD: This device is sensitive to static discharge and proper handling precautions are required.**

## ELECTRICAL CHARACTERISTICS

$\pm 5V$  power supplies, Tamb= 25C unless otherwise stated. Rf = 1k $\Omega$ , RL = 150 $\Omega$ , CL<= 10pF

PARAMETER	CONDITIONS	TEST	MIN	TYP	MAX	UNIT
Supply Voltage V+ operating range			4.75	5	5.25	V
Supply Voltage V- operating range			-5.25	-5	-4.75	V
Supply current		P	23	30	35	mA
Input Common mode voltage range		P		$\pm 3$		V
Input offset voltage		P		1	10	mV
Output offset voltage		P		2	20	mV
Input bias current, non-inverting input		P		5	10	$\mu A$
Input resistance		P	1.5	2	6.5	M $\Omega$
Open loop gain		P	48	61		dB
Output voltage swing		P		$\pm 3$		V
Output drive current		P	40			mA
Positive PSRR		P	49	57		dB
Negative PSRR		P	51	58		dB
Bandwidth -3dB	Av= +1, Vout = 200mV pk-pk	C		300		MHz
Bandwidth -0.1dB	Av= +1, Vout = 200mV pk-pk	C		30		MHz
Slew rate	Av= +1 Av = +2 Av = +10	C		400 400 400		V/ $\mu s$
Rise time	Vout = $\pm 1$ V, 10% - 90%	C		4.0		ns
Fall time	Vout = $\pm 1$ V, 10% - 90%	C		3.2		ns
Propagation delay	Vout = $\pm 2$ V, 50%	C		4.0		ns
Differential Gain	3.6MHz(NTSC) and 4.4MHz(PAL), RL = 150 $\Omega$	C		0.01		%
Differential phase	3.6MHz(NTSC) and 4.4MHz(PAL), RL = 150 $\Omega$	C		0.01		deg

Test - P = production tested. C = characterised



ISSUE 1 - FEBRUARY 2002

# ZXFV201

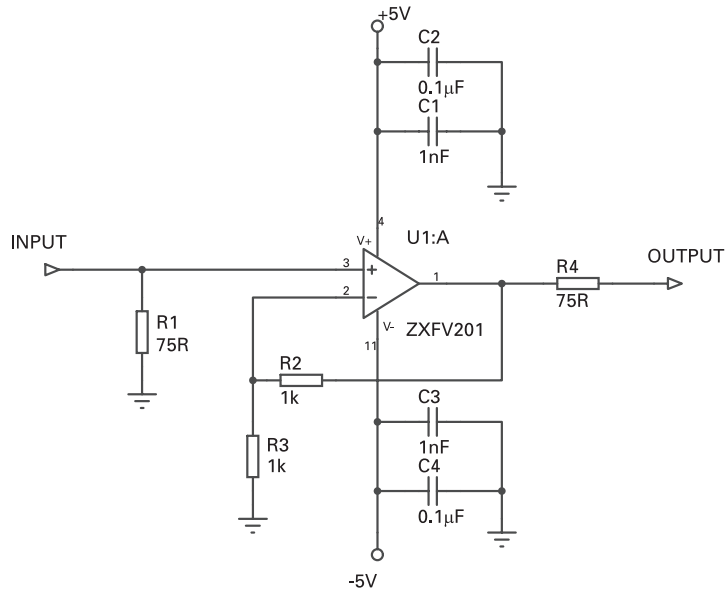

Figure 1: Typical Video Signal Application Circuit, Gain = 2 (overall gain = 1 for 75Ω load)

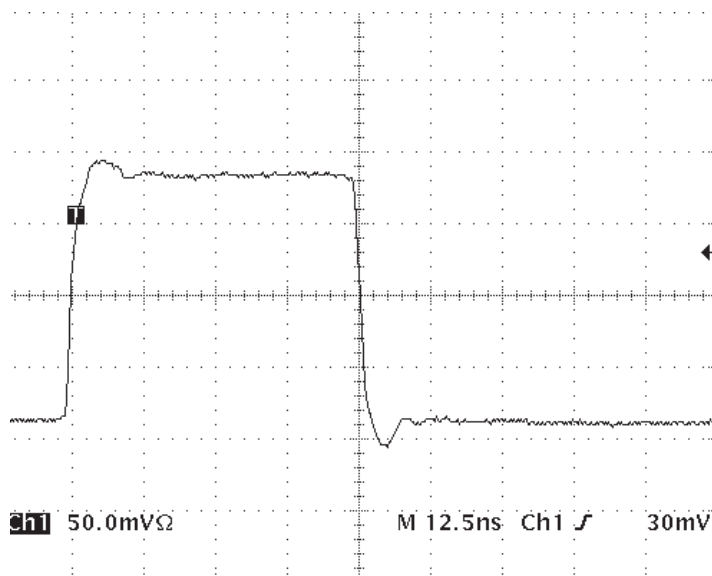

Figure 2: Pulse Response, Unity Gain, 1V pk-pk,  $R_F = 510\Omega$

**ZXFV201**



**ISSUE 1 - FEBRUARY 2002**

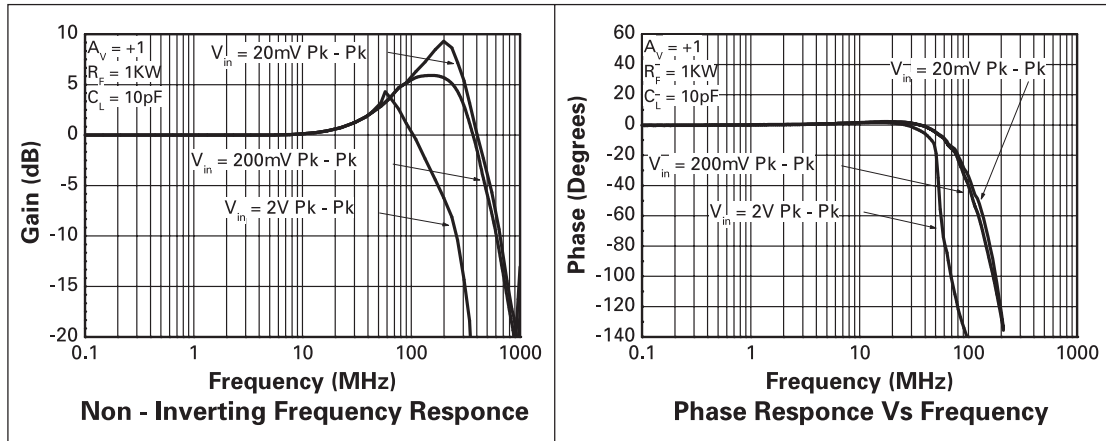

Figure 3: Graphs of Gain and Phase vs Frequency ( $R_L=150\Omega$ )

## APPLICATIONS INFORMATION

### Introduction

A typical circuit application is shown in Figure 1, above. This is suitable for 75 ohm transmission line connections at both the input and the output and is useful for distribution of wide-band signals such as video and xDSL via cables. The 75ohms reverse terminating resistor R4 gives the correct matching condition to a terminated video cable. The amplifier load is then 150 ohms in parallel with the local feedback network.

The wide bandwidth of this device necessitates some care in the layout of the printed circuit. A continuous ground plane is required under the device and its signal connection paths, to provide the shortest possible ground return paths for signals and power supply filtering. A double-sided or multi-layer PCB construction is required, with plated-through via holes providing closely spaced low-inductance connections from some components to the continuous ground plane.

For the power supply filtering, low inductance surface mount capacitors are normally required. It has been found that very good RF decoupling is provided on each supply using a 1000pF NPO size 0805 or smaller ceramic surface mount capacitor, closest to the device pin, with an adjacent 0.1uF X7R capacitor. Other configurations are possible and it may be found that a single 0.01uF X7R capacitor on each supply gives good results. However this should be supported by larger decoupling capacitors elsewhere on the printed circuit board. Values of 1 to 10  $\mu\text{F}$  are recommended, particularly where the voltage regulators are located more than a few inches from the device. These larger capacitors are recommended to be solid tantalum electrolytic or ceramic types.

Note particularly that the inverting input of this current feedback type of amplifier is sensitive to small amounts of capacitance to ground which occur as part of the practical circuit board layout. This capacitance affects bandwidth, frequency response peaking and pulse overshoot. Therefore to minimise this capacitance, the feedback components R2 and R3 of Figure1 should be positioned as close as possible to the inverting input connection.

The frequency response and pulse response will vary according to particular values of resistors and layout capacitance. The response can be tailored for the application to some extent by choice of the value of feedback resistor. Figure 2 shows an oscilloscope display of the pulse response for a practical double sided printed circuit board where  $R_F=510\text{ohms}$ .

# ZXFV201

## PACKAGE OUTLINE

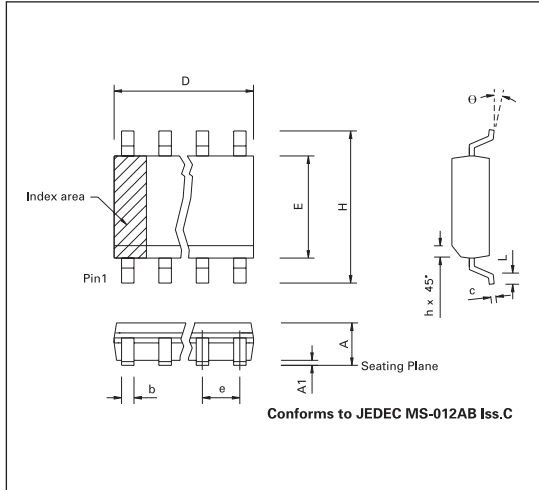

## PACKAGE DIMENSIONS

DIM	INCHES	
	MIN	MAX
A	0.053	0.069
A1	0.004	0.010
D	0.337	0.344
H	0.228	0.244
E	0.150	0.157
L	0.016	0.050
e	0.050 BSC	
b	0.013	0.020
c	0.008	0.010
θ	0°	8°
h	0.010	0.020

© Zetex plc 2001

Zetex plc  
Fields New Road  
Chadderton  
Oldham, OL9 8NP  
United Kingdom  
Telephone (44) 161 622 4422  
Fax: (44) 161 622 4420

Zetex GmbH  
Streitfeldstraße 19  
D-81673 München  
Germany  
Telefon: (49) 89 45 49 49 0  
Fax: (49) 89 45 49 49 49

Zetex Inc  
700 Veterans Memorial Hwy  
Hauppauge, NY11788  
USA  
Telephone: (631) 360 2222  
Fax: (631) 360 8222

Zetex (Asia) Ltd  
3701-04 Metroplaza, Tower 1  
Hing Fong Road  
Kwai Fong  
Hong Kong  
Telephone: (852) 26100 611  
Fax: (852) 24250 494

These offices are supported by agents and distributors in major countries world-wide.

This publication is issued to provide outline information only which (unless agreed by the Company in writing) may not be used, applied or reproduced for any purpose or form part of any order or contract or be regarded as a representation relating to the products or services concerned. The Company reserves the right to alter without notice the specification, design, price or conditions of supply of any product or service.

For the latest product information, log on to [www.zetex.com](http://www.zetex.com)

ISSUE 1 - FEBRUARY 2002