

# APD Receiver Module up to 3 Gb/s

## Key Features

- Hermetic, 14 pin butterfly package with multisourced footprint
- FC/PC, SC or ST connector
- InGaAs APD with low noise GaAs MMIC preamplifier
- AC-coupled, differential data output
- Operates between 1250 nm and 1620 nm
- 2.0 GHz minimum bandwidth
- -34 dBm typical sensitivity
- -3 dBm typical overload

## Applications

- WDM
- SDH STM-16 LH
- SONET OC-48 LR
- Digital receivers to 3 Gb/s
- Analog receivers to 2.0 GHz

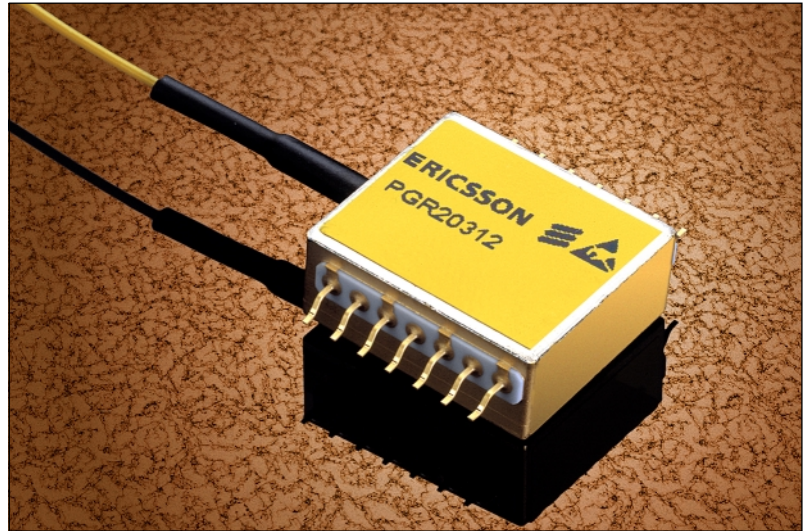

## Description

Fiber optic receiver front-end module for STM-16 and OC-48 WDM applications. The module includes an InGaAs Avalanche Photo Diode (APD), with a low noise GaAs MMIC preamplifier in a 14 pin butterfly package. The module is equipped with an internal thermistor. The single-mode fiber pigtail is terminated with a customer specified connector. The module operates between 1250 and 1620 nm. The electrical outputs are AC-coupled and differential.

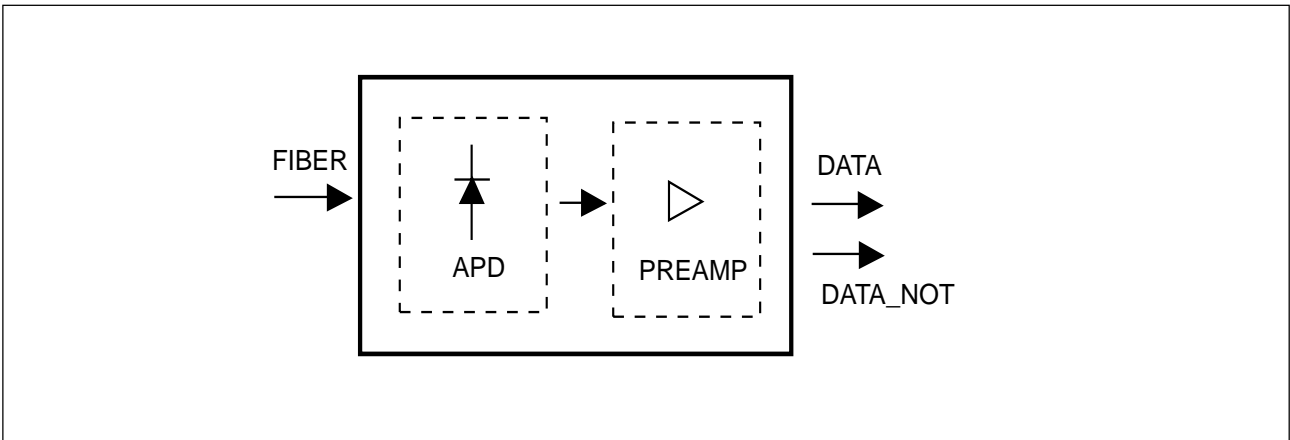

Figure 1. Block diagram

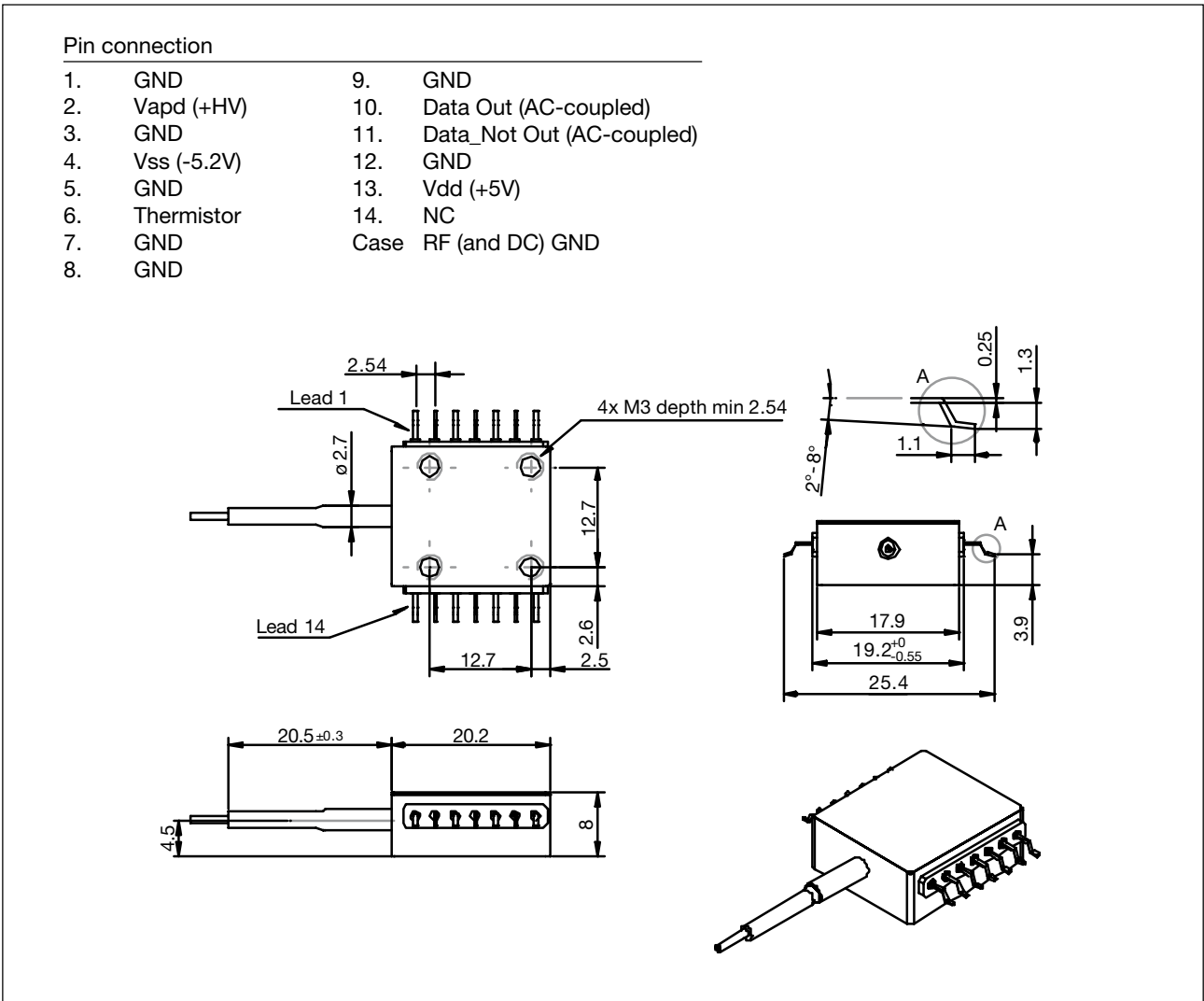

Figure 2. Pin description

## Optical and Electrical AC Characteristics

Electrical and optical characteristics over recommended operating conditions, unless otherwise noted.

Parameters are met by an individual differential output.

Parameter	Conditions	Symbol	Min	Typ	Max	Unit
Minimum bandwidth (-3dB)	-30dBm < Pf < -6dBm	BW <sub>min</sub>	2.0	2.5		GHz
Bandwidth variation	-30dBm < Pf < -6dBm BW <sub>max</sub> = α · BW <sub>min</sub>	α		1.2	1.3	
Gain peaking		δ <sub>Peak</sub>		0	2	dB
Sensitivity: Pf @ BER = 1·10 <sup>-10</sup>	2.5 Gbps NRZ, PRBS 2 <sup>23</sup> -1, λ = 1550 nm	Pr		-34	-32	dBm
Overload: Pf @ BER = 1·10 <sup>-10</sup>	2.5 Gbps NRZ, PRBS 2 <sup>23</sup> -1, λ = 1550 nm	Pol	-6	-3		dBm
Output signal swing	-30dBm < Pf < -6dBm R <sub>L</sub> = 50Ω, λ = 1550nm, ER ~10	V <sub>Out</sub>	30		800	mV <sub>p-p</sub>
AC transimpedance	R <sub>L</sub> = 50Ω, T <sub>z</sub> = dV <sub>Out</sub> /I <sub>Ph, ave</sub>	T <sub>z</sub>		3.0		kΩ
Logic sense	Data Out Data_Not Out			Light "ON" = Logic "LOW" Light "ON" = Logic "HIGH"		

## Optical and Electrical DC Characteristics

Electrical and optical characteristics over recommended operating conditions, unless otherwise noted.

Parameters are met by an individual differential output.

Parameter	Conditions	Symbol	Min	Typ	Max	Unit
DC Power supply current		I <sub>dd</sub> I <sub>ss</sub>		110 55	140 70	mA mA
Power consumption		P <sub>Con</sub>		0.8	1.1	W
APD Responsivity	λ = 1300 nm, M = 12 λ = 1550 nm, M = 12	R <sub>13(12)</sub> R <sub>15(12)</sub>		10.5 11.5		A/W A/W
Thermistor, NTC	T = 25°C	R <sub>Th(25)</sub>	2925	3000	3075	Ω
Optical reflectance		s11			-27	dB

## Recommended Operating Conditions

Parameter	Symbol	Min	Typ	Max	Unit
Optical wavelength	λ	1250		1620	nm
Case temperature	T <sub>Case</sub>	0		70	°C
DC Power supply voltage	V <sub>dd</sub> V <sub>ss</sub>	4.7 -5.5	5.0 -5.2	5.3 -4.9	V V
APD bias	V <sub>Apd</sub>	30		85	V

## Absolute Maximum Ratings

Parameter	Symbol	Min	Max	Unit
DC Power supply voltage	V <sub>dd</sub> V <sub>ss</sub>	-0.5 -7.0	6.5 0.5	V V
Storage temperature	T <sub>Stg</sub>	-40	85	°C

**CAUTION:** Stresses outside those listed in "Absolute Maximum Ratings" may cause permanent damage to the device. This is a stress only rating and operation of the device at these or any other conditions above those indicated in the operational sections of this specification is not implied.

## Handling Precautions

This device may be damaged as a result of electrostatic discharge (ESD). Take proper precautions during both handling and testing. This typically includes grounded wrist wraps, workbenches and floor mats in ESD controlled areas. Semiconductor devices may be damaged by current surges, use appropriate transient protection.

## Quality Assurance

Ericsson Microelectronics commitment to quality has been proven through a decade of semiconductor device production and has been confirmed to ISO 9001. Opto product qualification is made according to the intention of applicable Telcordia standards.

## Connector Options

FC/PC

SC

ST

(Other connectors available on request)

Information given in this data sheet is believed to be accurate and reliable. However no responsibility is assumed for the consequences of its use nor for any infringement of patents or other rights of third parties which may result from its use. No license is granted by implication or otherwise under any patent or patent rights of Ericsson Microelectronics. These products are sold only according to Ericsson Microelectronics' general conditions of sale, unless otherwise confirmed in writing.

Product specifications subject to change without notice.

### Ericsson Microelectronics AB

SE-164 81 Kista, Sweden

Telephone: +46 8 757 50 00

[www.ericsson.com/microelectronics](http://www.ericsson.com/microelectronics)

For local sales contacts, please refer to our website or call: Int + 46 8 757 47 00, Fax: +46 8 757 47 76

1522-PGR 203 12 Rev. B

© Ericsson Microelectronics AB, August 2000