

MOS FET Relays

G3VM-61B1/E1

Analog-switching MOS FET Relay for High Switching Currents, with Dielectric Strength of 2.5 kVAC between I/O.

- Upgraded G3VM-61 B/E Series.
- Switches minute analog signals.
- Leakage current of 1 μ A max. when output relay is open.

Application Examples

- Measurement devices
- Security systems
- Amusement machines

List of Models

Contact form	Terminals	Load voltage (peak value)	Model	Number per stick	Number per tape
SPST-NO	PCB terminals	60 VAC	G3VM-61B1	50	---
	Surface-mounting terminals		G3VM-61E1		
			G3VM-61E1(TR)	---	

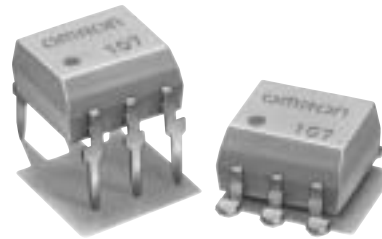

NEW Approval pending

Note: The actual product is marked differently from the image shown here.

Dimensions

Note: All units are in millimeters unless otherwise indicated.

G3VM-61B1

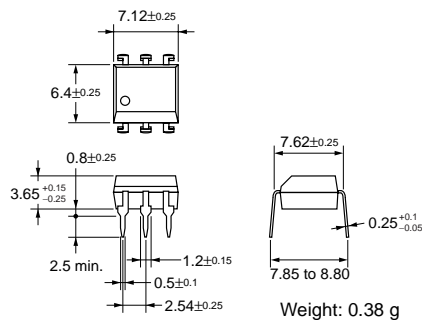
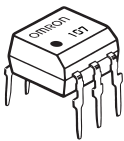

Note: The actual product is marked differently from the image shown here.

G3VM-61E1

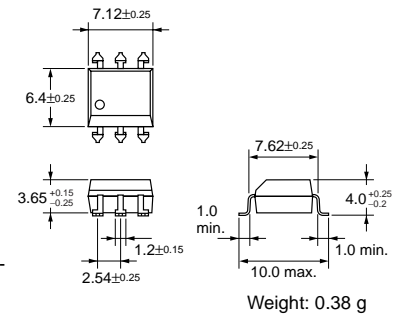
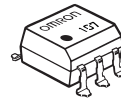

Note: The actual product is marked differently from the image shown here.

Terminal Arrangement/Internal Connections (Top View)

G3VM-61B1

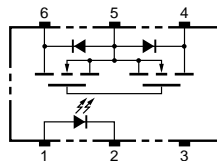

G3VM-61E1

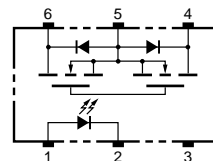

PCB Dimensions (Bottom View)

G3VM-61B1

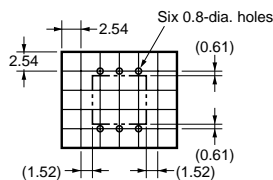

Actual Mounting Pad Dimensions (Recommended Value, Top View)

G3VM-61E1

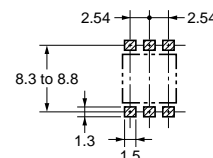

Absolute Maximum Ratings (Ta = 25°C)

Item	Symbol	Rating	Unit	Measurement Conditions		
Input	LED forward current	I_F	50	mA		
	Repetitive peak LED forward current	I_{FP}	1	A	100 μ s pulses, 100 pps	
	LED forward current reduction rate	$\Delta I_F/^\circ\text{C}$	-0.5	mA/°C	Ta \geq 25°C	
	LED reverse voltage	V_R	5	V		
	Connection temperature	T_j	125	°C		
Output	Output dielectric strength	V_{OFF}	60	V		
	Continuous load current	Connection A	I_O	500	mA	
		Connection B		500		
		Connection C		1,000		
	ON current reduction rate	Connection A	$\Delta I_{ON}/^\circ\text{C}$	-0.5	mA/°C	Ta \geq 25°C
		Connection B		-0.5		
Connection C			-10.0			
Connection temperature	T_j	125	°C			
Dielectric strength between input and output (See note 1.)	V_{I-O}	2,500	Vrms	AC for 1 min		
Operating temperature	T_a	-40 to +85	°C	With no icing or condensation		
Storage temperature	T_{stg}	-55 to +125	°C	With no icing or condensation		
Soldering temperature (10 s)	---	260	°C	10 s		

Note: 1. The dielectric strength between the input and output was checked by applying voltage between all pins as a group on the LED side and all pins as a group on the light-receiving side.

Connection Diagram

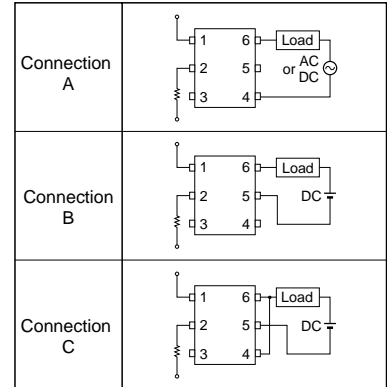

Electrical Characteristics (Ta = 25°C)

Item	Symbol	Minimum	Typical	Maximum	Unit	Measurement conditions		
Input	LED forward voltage	V_F	1.0	1.15	1.3	V	$I_F = 10$ mA	
	Reverse current	I_R	---	---	10	μ A	$V_R = 5$ V	
	Capacity between terminals	C_T	---	30	---	pF	$V = 0$, $f = 1$ MHz	
	Trigger LED forward current	I_{FT}	---	1.6	3	mA	$I_O = 500$ mA	
Output	Maximum resistance with output ON	Connection A	R_{ON}	---	1	2	Ω	$I_F = 5$ mA, $I_O = 500$ mA
		Connection B		---	0.5	1	Ω	$I_F = 5$ mA, $I_O = 500$ mA
		Connection C		---	0.25	---	Ω	$I_F = 5$ mA, $I_O = 1,000$ mA
	Current leakage when the relay is open	I_{LEAK}	---	---	1.0	μ A	$V_{OFF} = 60$ V	
Capacity between I/O terminals	C_{I-O}	---	0.8	---	pF	$f = 1$ MHz, $V_s = 0$ V		
Insulation resistance	R_{I-O}	1,000	---	---	M Ω	$V_{I-O} = 500$ VDC, $RoH \leq 60\%$		
Turn-ON time	tON	---	0.8	2.0	ms	$I_F = 5$ mA, $R_L = 200 \Omega$, $V_{DD} = 20$ V (See note 2.)		
Turn-OFF time	tOFF	---	0.1	0.5	ms			

Note: 2. Turn-ON and Turn-OFF Times

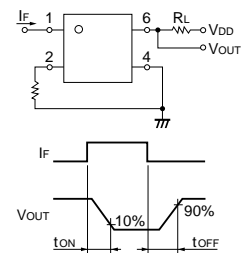

Recommended Operating Conditions

Use the G3VM under the following conditions so that the Relay will operate properly.

Item	Symbol	Minimum	Typical	Maximum	Unit
Output dielectric strength	V_{DD}	---	---	48	V
Operating LED forward current	I_F	5	7.5	25	mA
Continuous load current	I_O	---	---	500	mA
Operating temperature	T_a	-20	---	65	°C

Engineering Data

Load Current vs. Ambient Temperature

G3VM-61B1(E1)

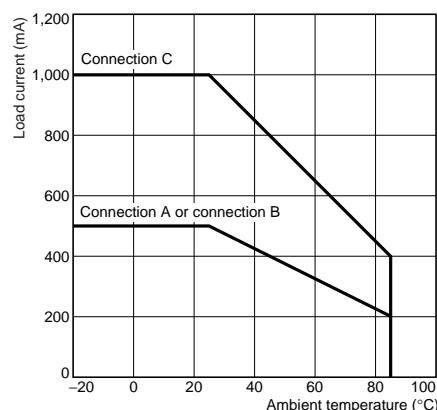

Safety Precautions

Refer to page 6 for precautions common to all G3VM models.