

EE-SX4009-P10

Photomicrosensor (Transmissive)

■ Dimensions

Note: All units are in millimeters unless otherwise indicated.

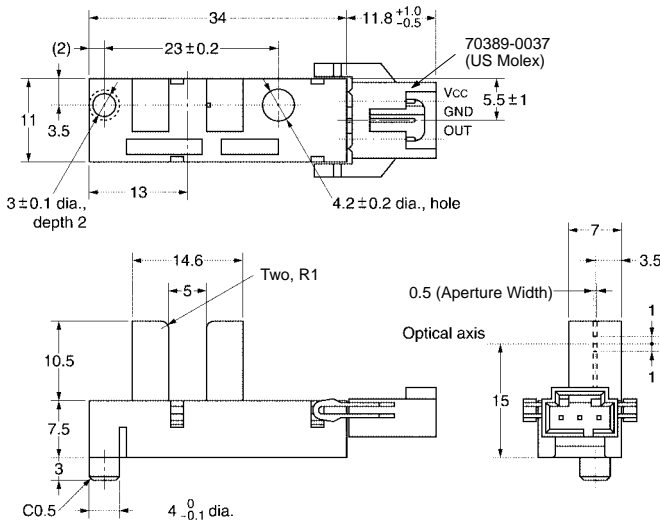

Internal Circuit

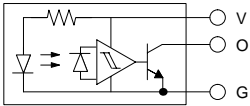

Unless otherwise specified, the tolerances are as shown below.

Terminal No.	Name
V	Power supply (V _{CC})
O	Output (OUT)
G	Ground (GND)

Dimensions	Tolerance
4 mm max.	±0.2
4 < mm ≤ 16	±0.3
16 < mm ≤ 63	±0.5

Recommended Mating Connectors:
US Molex
50-57-9403
15-47-4033
14-56-2036 (AWG28)
14-56-2034 (AWG26)
14-56-2032 (AWG24)
14-56-2037 (AWG22)

■ Features

- Screw-mounting model.
- High resolution with a 0.5-mm-wide sensing aperture.
- With a 5-mm-wide groove.
- Photo IC output signals directly connect with C-MOS and TTL.
- Connects to US Molex connectors.

■ Absolute Maximum Ratings (Ta = 25°C)

Item	Symbol	Rated value
Power supply voltage	V _{CC}	10 V
Output voltage	V _{OUT}	28 V
Output current	I _{OUT}	16 mA
Permissible output dissipation	P _{OUT}	250 mW (see note)
Ambient temperature	Operating	T _{opr} -25°C to 75°C
	Storage	T _{stg} -40°C to 85°C
Soldering temperature	T _{sol}	---

Note: Refer to the temperature rating chart if the ambient temperature exceeds 25°C.

■ Electrical and Optical Characteristics (Ta = 25°C, V_{CC} = 5 V ±10%)

Item	Symbol	Value	Condition
Current consumption	I _{CC}	30 mA max.	With and without incident
Low-level output voltage	V _{OL}	0.3 V max.	I _{OUT} = 16 mA with incident
High-level output voltage	V _{OH}	(V _{CC} × 0.9) V min.	V _{OUT} = V _{CC} without incident, R _L = 47 kΩ
Response frequency	f	3 kHz min.	V _{OUT} = V _{CC} , R _L = 47 kΩ (see note)

Note: The value of the response frequency is measured by rotating the disk as shown below.

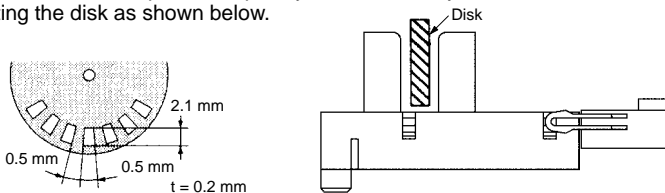

■ Engineering Data

Output Allowable Dissipation vs. Ambient Temperature Characteristics

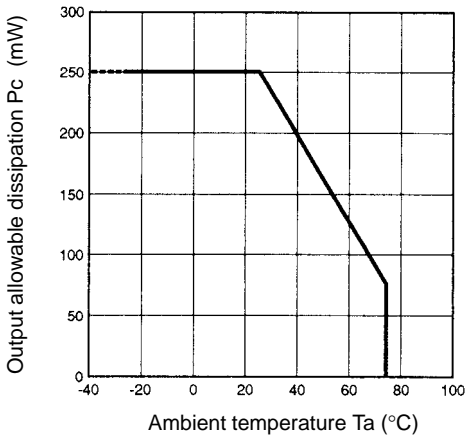

Sensing Position Characteristics (Typical)

