

**26 cm (10.4 inches), 640 × 480 pixels, 262,144 colors,  
Incorporated two-lamp/Edge-light type backlight  
Wide viewing angle**

**DESCRIPTION**

NL6448BC33-31 is a TFT (thin film transistor) active matrix color liquid crystal display (LCD) comprising amorphous silicon TFT attached to each signal electrode, a driving circuit and a backlight. NL6448BC33-31 has a built-in backlight. Backlight includes long-life-lamps and the lamps are replaceable.

The 26 cm (10.4 inches) diagonal display area contains 640 × 480 pixels and can display 262,144 colors simultaneously.

NL6448BC33-31 is suitable for industrial application use because of the wide viewing angle and the high luminance. Also, the viewing direction is selectable either upper or lower side by changing scan direction.

NL6448BC33-31 interface is compatible with NL6448AC33-18, -18A, -18B and -27.

**FEATURES**

- Wide viewing angle (with Retardation Film)
- Smooth polarizer surface (No antiglare treatment)
- High luminance (350 cd/m<sup>2</sup>, typ.: saturated value, at room temp.)
- Low reflection
- 6-bit digital RGB signals
- Data enable function
- Backlight with two long-life-time lamps (one lamp holder, inverter-less)
- Lamp holder replaceable (Type No.: 104LHS31)
- Reversible scan direction (with DPS pin)
- Replaceable lamp holders (Type No.: 104LHS31)
- Recommended inverter (Part No.: 104PWRI)
- Best viewing angle select function (with MVA terminal)
- Luminance control
- Easy to attach a touch panel

**APPLICATIONS**

- Display terminals for control system
- Monitors for process controller
- Industrial PCs



The information in this document is subject to change without notice.

**STRUCTURE AND FUNCTIONS**

A color TFT (thin film transistor) LCD module is comprised of a TFT liquid crystal panel structure, LSIs for driving the TFT array, and a backlight assembly. The TFT panel structure is created by sandwiching liquid crystal material in the narrow gap between a TFT array glass substrate and a color filter glass substrate. After the driver LSIs are connected to the panel, the backlight assembly is attached to the backside of the panel.

RGB (red, green, blue) data signals from a source system is modulated into a form suitable for active matrix addressing by the onboard signal processor and sent to the driver LSIs which in turn addresses the individual TFT cells.

Acting as an electro-optical switch, each TFT cell regulates light transmission from the backlight assembly when activated by the data source. By regulating the amount of light passing through the array of red, green, and blue dots, color images are created with clarity.

**OUTLINE OF CHARACTERISTICS (at room temperature)**

Display area	211.2 (H) × 158.4 (V) mm
Drive system	a-Si TFT active matrix
Display colors	262,144 colors
Number of pixels	640 × 480 pixels
Pixel arrangement	RGB vertical stripe
Pixel pitch	0.33 (H) × 0.33 (V) mm
Module size	243.0 (H) × 185.1 (V) × 10.75 typ. (D) mm
Weight	530 g (typ.)
Contrast ratio	300 : 1 (typ.)
Viewing angle (more than the contrast ratio of 10 : 1)	Horizontal : 50° (typ., left side, right side) Vertical : 40° (typ., up side), 45° (typ., down side)
Designed viewing direction	Wider viewing angle without image reversal : up side (12 o'clock normal scan) down side (6 o'clock reverse scan) Wider viewing angle with contrast ratio : down side (6 o'clock normal scan) up side (12 o'clock reverse scan) Optimum grayscale ( $\gamma = 2.2$ ) : perpendicular
Polarizer pencil-hardness 2H (Min., at JIS K5400)	
Color gamut	43% (typ. at center, to NTSC)
Response time	15 ms (typ.), white to black
Luminance	350 cd/m <sup>2</sup> (TYP)
Signal system	6-bit digital signals for each of RGB primary colors, synchronous signals (Hsync, Vsync), dot clock (CLK)
Supply voltages	3.3 V [5.0 V] (Logic, LCD driving), 12.0 V (Backlight)
Backlight	Edge light type, two cold cathode fluorescent lamps (cold cathode type) [Replaceable parts] Lamp holder: type No.104LHS31
Power consumption	6.8 W (typ., at 3.3 V, 12.0 V)

BLOCK DIAGRAM

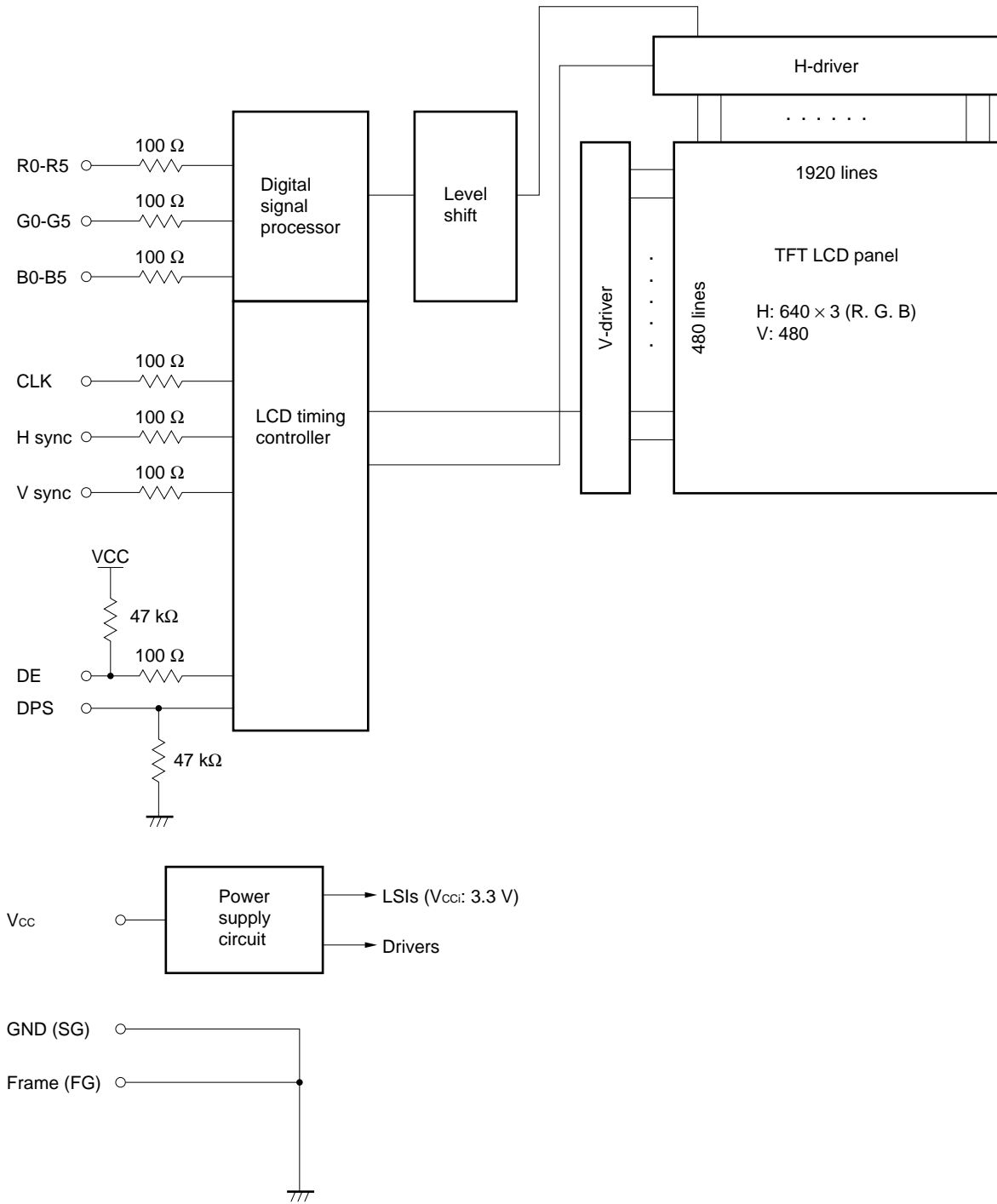

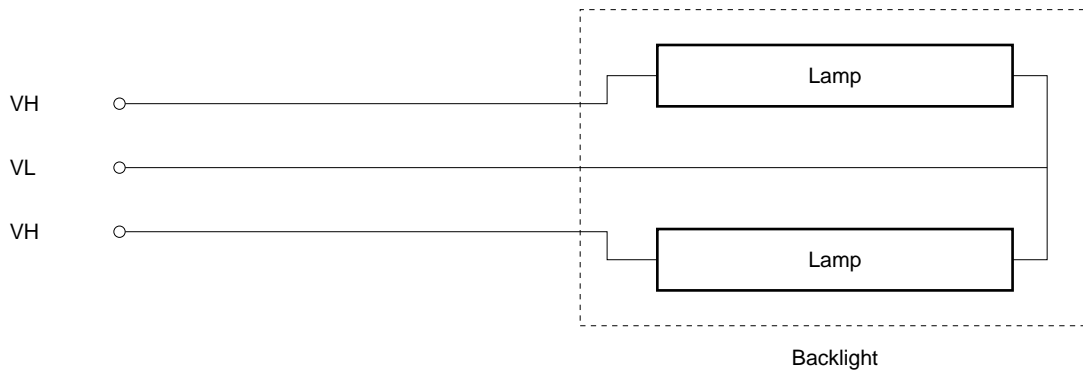

<In case of connecting NEC recommended inverter>

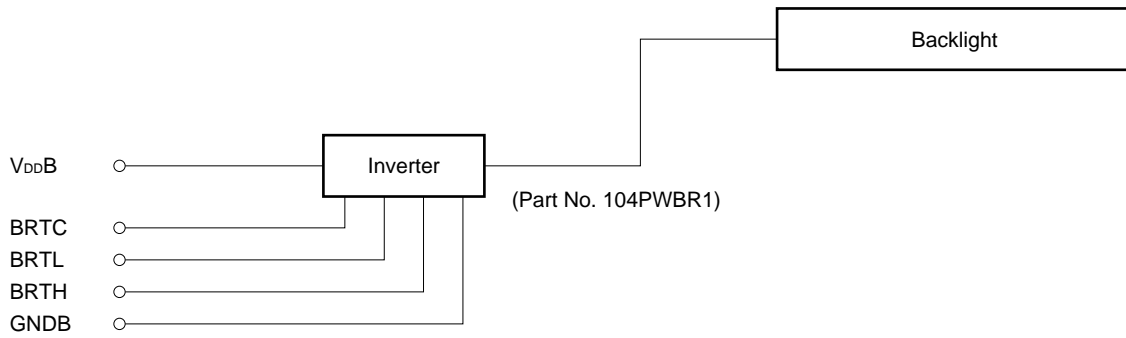

**GENERAL SPECIFICATIONS**

Items	Specifications	Unit
Module size	243.0 ± 0.5 (H) × 185.1 ± 0.5 (V) × 11.5 max. (D)	mm
Display area	211.2 (H) × 158.4 (V)	mm
Number of dots	640 × 3 (H) × 480 (V)	dot
Number of pixels	640 (H) × 480 (V)	pixel
Dot pitch	0.11 (H) × 0.33 (V)	mm
Pixel pitch	0.33 (H) × 0.33 (V)	mm
Pixel arrangement	RGB (Red, Green, Blue) vertical stripe	–
Display colors	262,144	color
Weight	550 (max.)	g

**ABSOLUTE MAXIMUM RATINGS**

Parameters	Symbols	Ratings	Unit	Remarks	
Supply voltage	V <sub>CC</sub>	–0.3 to 6.5	V	T <sub>a</sub> = 25°C	
Input voltage	V <sub>i</sub>	–0.3 to V <sub>CC</sub> +0.3	V		
Lamp voltage	V <sub>L</sub>	2000	V <sub>rms</sub>	–	
Storage temp.	T <sub>ST</sub>	–20 to 60	°C		
Operating temp.	T <sub>OP</sub>	0 to 50	°C	Module surface <b>Note</b>	
Humidity (no condensation)	RH	≤ 95% relative humidity	–	T <sub>a</sub> ≤ 40°C	No condensation
		≤ 85% relative humidity	–	40 < T <sub>a</sub> ≤ 50°C	
		Absolute humidity shall not exceed T <sub>a</sub> = 50°C, 85% relative humidity level.	–	T <sub>a</sub> > 50°C	

**Note** Measured at the display area

**ELECTRICAL CHARACTERISTICS**

(1) Logic, LCD driving

T<sub>a</sub> = 25°C

Parameters	Symbols	MIN.	TYP.	MAX.	Unit	Remarks
Supply voltage	V <sub>CC</sub>	3.0 (4.75)	3.3 (5.0)	3.6 (5.25)	V	V <sub>CC</sub> = 3.3 V (V <sub>CC</sub> = 5.0 V)
Logic input Low voltage	V <sub>IL</sub>	0	–	V <sub>CC</sub> × 0.3	mV	CMOS level
Logic input High voltage	V <sub>IH</sub>	V <sub>CC</sub> × 0.7	–	5.25	V	
Supply current	I <sub>CC</sub>	– –	325 <b>Note</b> (250)	370 (300)	mA	V <sub>CC</sub> = 3.3 V (V <sub>CC</sub> = 5.0 V)

**Note** Checkered flag pattern (in EIAJ ED-2522)

(2) Backlight

T<sub>a</sub> = 25°C

Parameters	Symbols	MIN.	TYP.	MAX.	Unit	Remarks
Lamp current	I <sub>L</sub>	2.0	5.0	5.5	mArms	with one lamp
Lamp voltage	V <sub>L</sub>	–	510	–	V <sub>rms</sub>	–
Lamp turn on voltage	V <sub>s</sub>	840	–	–	V <sub>rms</sub>	T <sub>a</sub> = 25°C
		1265	–	–		T <sub>a</sub> = 0°C
Oscillator frequency	F <sub>t</sub>	50	54	58	kHz	<b>Note</b>

**Note** Recommended value of “F<sub>t</sub>”.

- F<sub>t</sub> is within the specification.

and

- $F_t = \frac{1}{4th} \times (2n - 1)$       th: Hsync period  
n : a natural number (1, 2, 3, ...)

If F<sub>t</sub> is out of the recommended value, interference between F<sub>t</sub> frequency and Hsync frequency may cause beat on the display.

**SUPPLY VOLTAGE SEQUENCE**

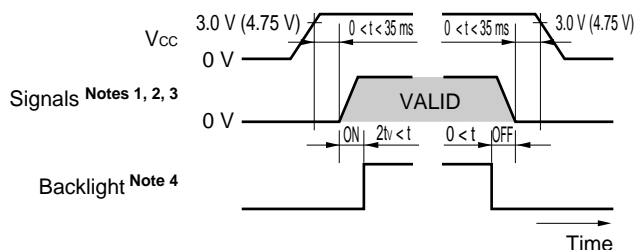

- Notes**
1. Signals: CLK, Hsync, Vsync, DE, DATA (R0-R5, G0-G5, B0-B5)
  2. The supply voltage for input signals should be the same as V<sub>CC</sub>.
  3. Apply V<sub>DDB</sub> within the LCD operation period. When the backlight turns on before LCD operation or the LCD operation turns off before the backlight turns off, the display may momentarily become white.
  4. While the power is off, please keep whole signals at low level or high impedance.

**INTERFACE PIN CONNECTIONS**

(1) Interface signals, power supply

- |                                  |                                     |
|----------------------------------|-------------------------------------|
| Module side connector            | Mating connector                    |
| CN1 ... DF9C-31P-1V (No.1 to 30) | DF9-31S-1V or DF9M-31S-1R ..... (1) |
|                                  | IL-310-T31S-VF ..... (2)            |
- Supplier: (1) HIROSE ELECTRIC CO., LTD., (2) Japan Aviation Electronics Industry Limited (JAE)

Pin No.	Symbols	Functions
1	GND	Ground
2	CLK	Dot clock
3	Hsync	Horizontal sync.
4	Vsync	Vertical sync.
5	GND	Ground
6	R0	Red data (LSB)
7	R1	Red data
8	R2	Red data
9	R3	Red data
10	R4	Red data
11	R5	Red data (MSB)
12	GND	Ground
13	G0	Green data (LSB)
14	G1	Green data
15	G2	Green data
16	G3	Green data
17	G4	Green data
18	G5	Green data (MSB)

Pin No.	Symbols	Functions
19	GND	Ground
20	B0	Blue data (LSB)
21	B1	Blue data
22	B2	Blue data
23	B3	Blue data
24	B4	Blue data
25	B5	Blue data (MSB)
26	GND	Ground
27	DE	Data enable
28	Vcc	Power supply
29	Vcc	Power supply
30	MVA	Best Viewing Select
31	DPS	Scan direction select

LSB : Least Significant Bit  
 MSB : Most Significant Bit

- Notes**
1. Vcc: All Vcc terminals should be connected to 3.3V or 5.0 V.
  2. GND is connected to the frame of the LCD module.
  3. DE: DE/Fixed mode select is as follows.
    - { Data enable signal = DE mode
    - { Vcc or Open = Fixed mode
  4. MVA: MVA changes best viewing angle at gray scale screen.
    - { Vcc or Open = Perpendicular (best viewing angle: 0°)
    - { GND = down side (best viewing angle: -10°)
  5. DPS: DPS changes display scan direction.
    - { GND or Open = Scan direction will be decided by the setting of SW1.
    - { Vcc = Reverse scan

DISPLAY POSITION about another way for reversible scan.  
 When DPS is Vcc, reverse scan is selected even if SW1 is set at normal scan.

(2) Backlight

- Lamp side connector                      Mating connector  
     CN2 ... BHR-03VS-1                      SM03 (4.0)B-BHS-TB  
     Supplier: J.S.T TRADING COMPANY, LTD.

Pin No.	Symbols	Functions
1	V <sub>L</sub>	Power supply (low)
2	V <sub>H</sub>	Power supply (high)
3	V <sub>H</sub>	Power supply (high)

(3) Connector locations

<Connector locations>

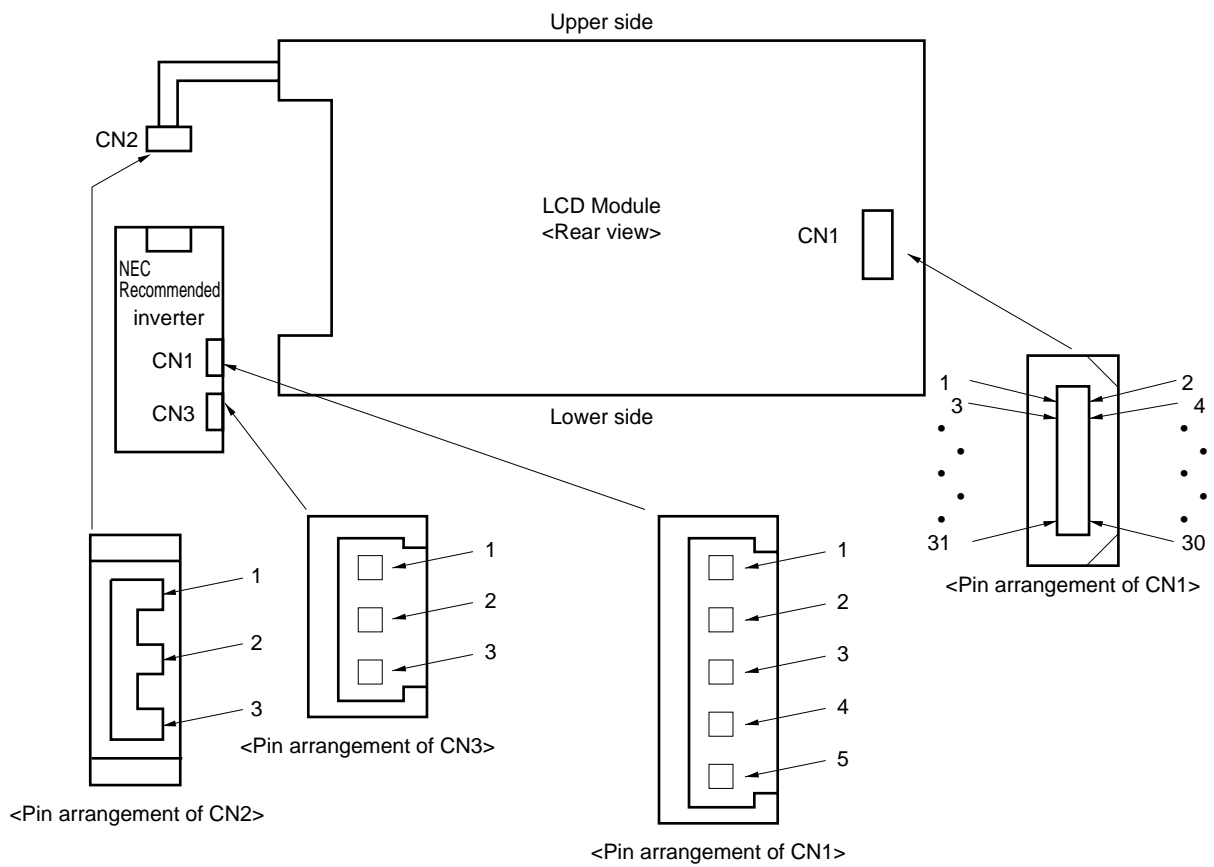

Incase of connecting NEC recommended inverter



- Inverter side connector 1                      Mating connector 1  
 CN1 ... LZ-5P-SL-SMT                      LZ-5S-SC3  
 Supplier: Japan Aviation Electronics Industry Limited (JAE)

Pin No.	Symbols	Functions	Pin No.	Symbols	Functions
1	V <sub>DD</sub> B	Power supply (12 V)	4	GNDB	Backlight ground
2	V <sub>DD</sub> B	Power supply (12 V)	5	BRTHL	Luminance select <b>Note</b>
3	GNDB	Backlight ground			

**Note** High luminance (100%): BRTHL = High (+5 V) or open  
 Low luminance (60%): BRTHL = Low (GNDB level)

- Inverter side connector 2                      Mating connector 2  
 CN3 ... IL-Z-3PL-SMTY                      IL-Z-3S-S125C3  
 Supplier: Japan Aviation Electronics Industry Limited (JAE)

Pin No.	Symbols	Functions
1	BRTC	Backlight ON/OFF signal <b>Note 1</b>
2	BRTH	Luminance control input <b>Note 2</b>
3	BRTL	Luminance control input <b>Note 2</b>

**Notes 1.** CMOS level

Backlight ON: BRTC = High (+5 V) or open  
 Backlight OFF : BRTC = Low (GNDB level)

- 2.** <1> A way of luminance control by a variable resistor  
 This way works when BRTHL (No.5 pin) of CN1 is opened.

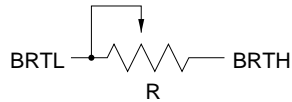

Mating variable resistor : 10 kΩ ±5%  
 Minimum luminance (50%) : R = 0 Ω  
 Maximum luminance (100%): R = 10 kΩ

- <2> A way of luminance control by a voltage

This way works when BRTHL and BRTL are opened. The range of input voltage between BRTH and GNDB is as follows.

Minimum luminance (50%) : 2.5 V  
 Maximum luminance (100%): ≤ 1.2 V

DISPLAY COLORS vs. INPUT DATA SIGNALS

Display colors		Data signal (0: Low level, 1: High level)																	
		R5	R4	R3	R2	R1	R0	G5	G4	G3	G2	G1	G0	B5	B4	B3	B2	B1	B0
Basic colors	Black	0	0	0	0	0	0	0	0	0	0	0	0	0	0	0	0	0	0
	Blue	0	0	0	0	0	0	0	0	0	0	0	0	1	1	1	1	1	1
	Red	1	1	1	1	1	1	0	0	0	0	0	0	0	0	0	0	0	0
	Magenta	1	1	1	1	1	1	0	0	0	0	0	0	1	1	1	1	1	1
	Green	0	0	0	0	0	0	1	1	1	1	1	1	0	0	0	0	0	0
	Cyan	0	0	0	0	0	0	1	1	1	1	1	1	1	1	1	1	1	1
	Yellow	1	1	1	1	1	1	1	1	1	1	1	1	0	0	0	0	0	0
	White	1	1	1	1	1	1	1	1	1	1	1	1	1	1	1	1	1	1
Red grayscale	Black	0	0	0	0	0	0	0	0	0	0	0	0	0	0	0	0	0	0
		0	0	0	0	0	1	0	0	0	0	0	0	0	0	0	0	0	0
	dark	0	0	0	0	1	0	0	0	0	0	0	0	0	0	0	0	0	0
	↑																		
	↓																		
	bright	1	1	1	1	0	1	0	0	0	0	0	0	0	0	0	0	0	0
	Red	1	1	1	1	1	0	0	0	0	0	0	0	0	0	0	0	0	0
Green grayscale	Black	0	0	0	0	0	0	0	0	0	0	0	0	0	0	0	0	0	0
		0	0	0	0	0	0	0	0	0	0	1	0	0	0	0	0	0	0
	dark	0	0	0	0	0	0	0	0	0	1	0	0	0	0	0	0	0	0
	↑																		
	↓																		
	bright	0	0	0	0	0	0	1	1	1	1	0	1	0	0	0	0	0	0
	Green	0	0	0	0	0	0	1	1	1	1	1	1	0	0	0	0	0	0
Blue grayscale	Black	0	0	0	0	0	0	0	0	0	0	0	0	0	0	0	0	0	0
		0	0	0	0	0	0	0	0	0	0	0	0	0	0	0	0	0	1
	dark	0	0	0	0	0	0	0	0	0	0	0	0	0	0	0	0	1	0
	↑																		
	↓																		
	bright	0	0	0	0	0	0	0	0	0	0	0	0	1	1	1	1	0	1
	Blue	0	0	0	0	0	0	0	0	0	0	0	0	1	1	1	1	1	1

**Note** The combination of 6-bit signals (64 grayscale level) results in 262144 (64 × 64 × 64) colors.

**INPUT SIGNAL TIMINGS**

(1) Input signal specifications (DE mode is default.)

Parameters		Symbols	MIN.	TYP.	MAX.	Unit	Remarks
CLK	Frequency	1/tc	–	25.175	–	MHz	39.72 ns (typ.)
	Duty	tch/tc	0.4	0.5	0.6	–	–
	Rise, fall	tcrf	–	–	10	ns	–
Hsync	Period	th	30.0	31.778	33.6	μs	31.468 kHz (typ.)
			–	800	–	CLK	
	Display period	thd	640			CLK	–
	Front-porch	thf	–	16	–	CLK	Fixed mode
			2	16	–		DE mode
	Pulse width	thp	10	96	–	CLK	Fixed mode
			10	96	–		DE mode
	Back-porch	thb	–	48	134	CLK	Fixed mode
			4	48	–		DE mode
	thp + thb		144			CLK	Fixed mode
			14	144	–		adjustable range by DE signal
	CLK-Hsync timing	thch	12	–	–	ns	–
	Hsync-CLK timing	thcs	8	–	–	ns	–
	Hsync-Vsync timing	tvh	1	–	–	CLK	–
Vsync-Hsync timing	tvS	30	–	–	ns	–	
Rise, fall	thrf	–	–	10	ns	–	
Vsync	Period	tv	16.1	16.683	17.2	ms	59.94 Hz (typ.)
			–	525	–	H	
	Display period	tvD	480			H	–
	Front-porch	tvf	–	12	–	H	Fixed mode
			0	12	–		DE mode
	Pulse width	tvp	1	2	–	H	Fixed mode
			1	2	–		DE mode
	Back-porch	tvb	–	31	–	H	Fixed mode
			4	31	–		DE mode
	tvp + tvb		–	33	–	H	Fixed mode
5			33	–	DE mode		
Rise, fall	tvrf	–	–	10	ns	–	
DATA (R0-R5 G0-G5 B0-B5)	CLK-DATA timing	tds	8	–	–	ns	–
	DATA-CLK timing	tdh	12	–	–	ns	–
	Rise, fall	tdrf	–	–	10	ns	–
DE	DE-CLK timing	tes	8	–	–	ns	DE mode
	CLK-DE timing	teh	12	–	–	ns	
	Rise, fall	terf	–	–	10	ns	

**Note** All parameters should be kept within the specified range.

(2) Definition of input signal timings

<Vertical>

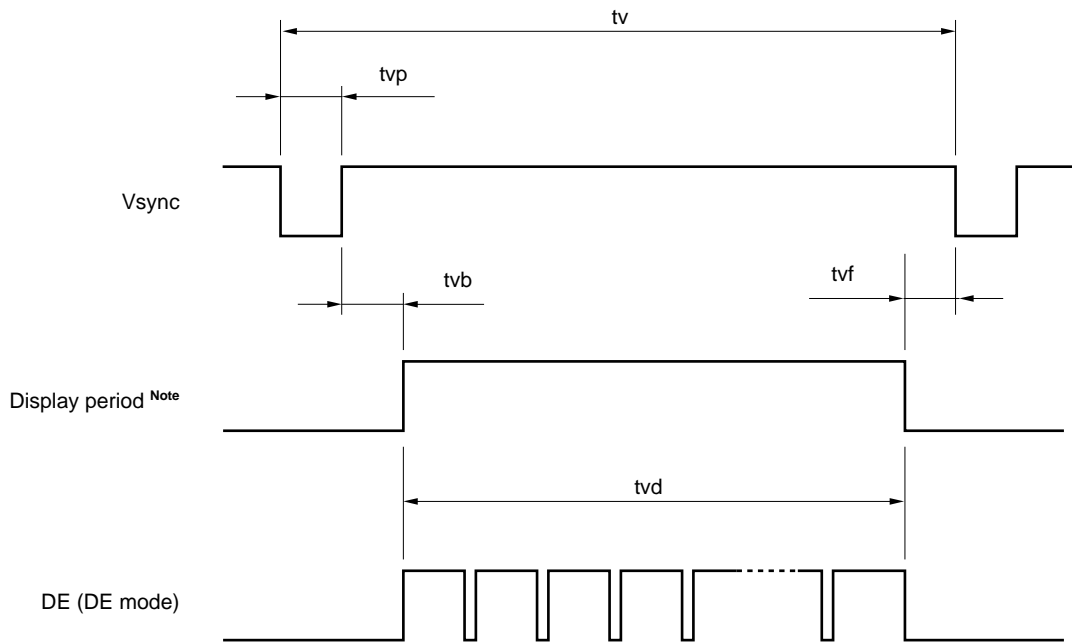

<Horizontal>

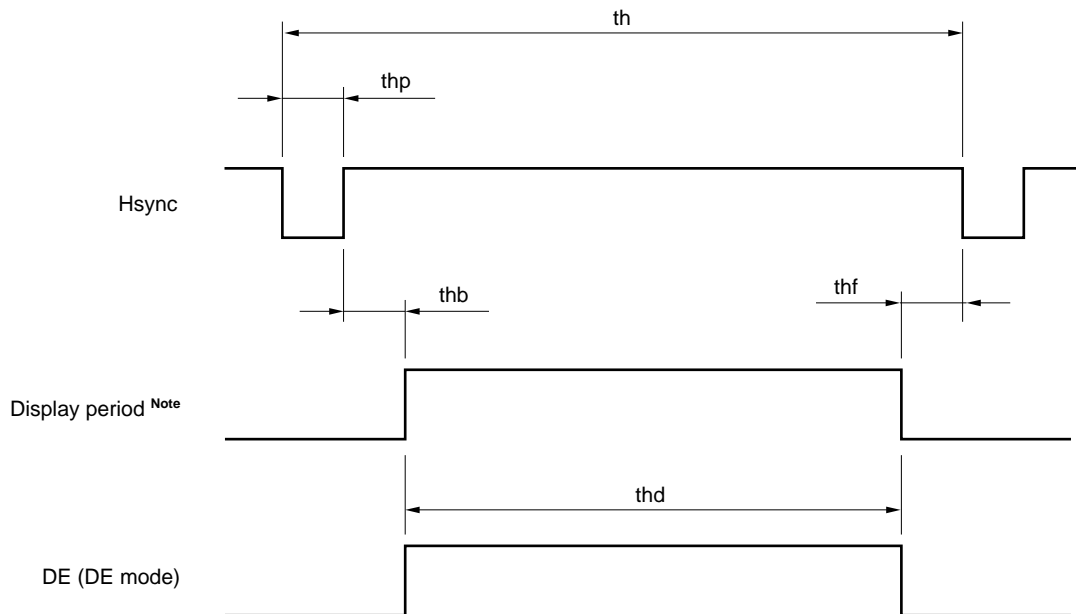

**Notes** 1. These do not exist as signals.

2. Keep  $thp + thb$  and  $tv_p + tv_b$  within the value shown in the table of input signal timing, otherwise display position is shifted to right or left side, or to up or down side.

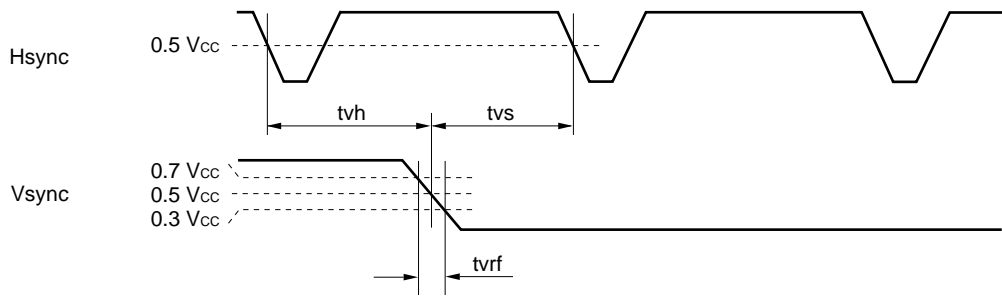
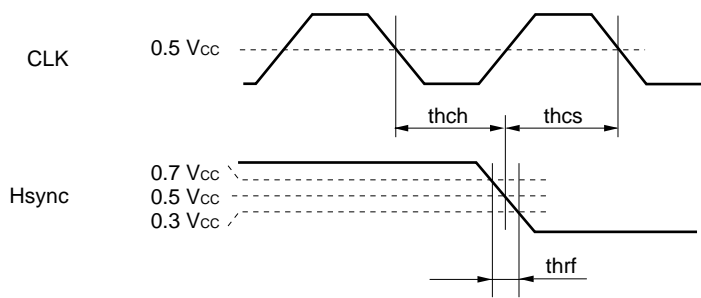
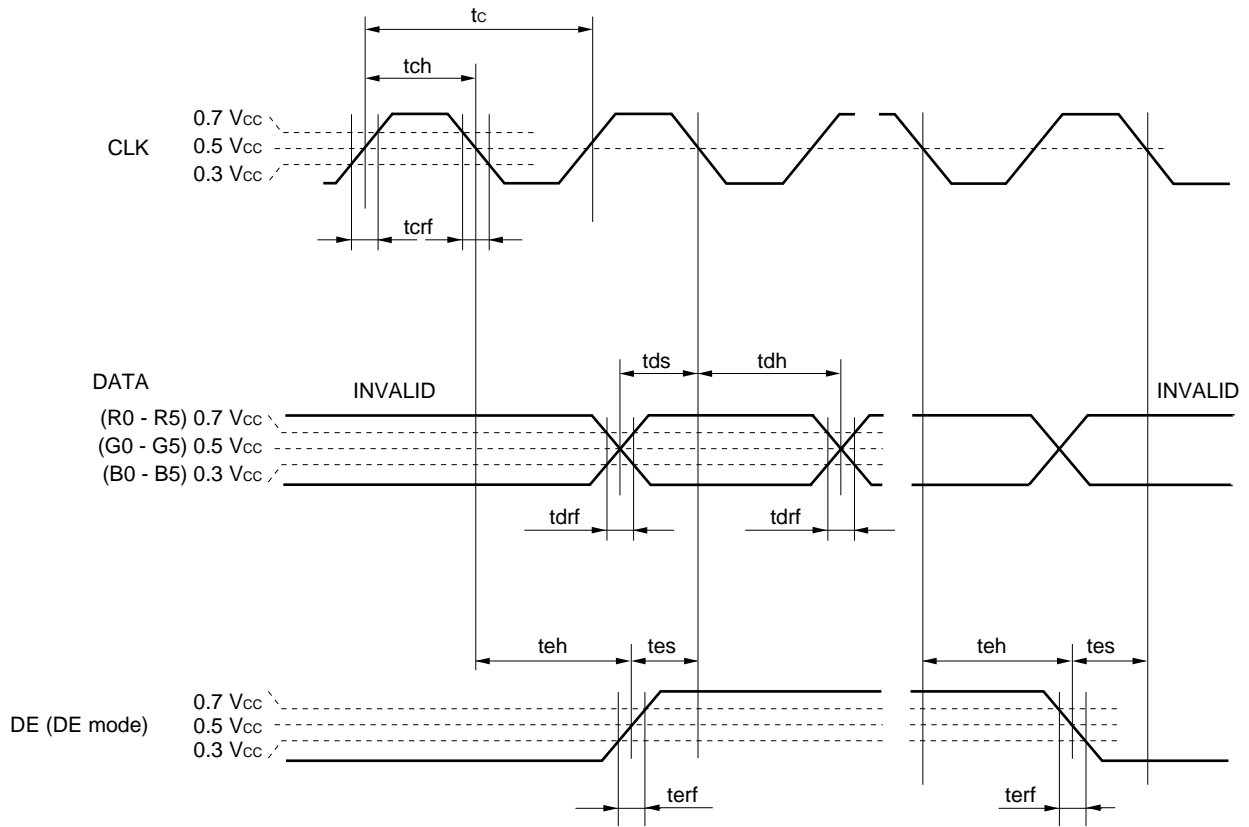

(3) Input signal timing chart

(a) Fixed mode

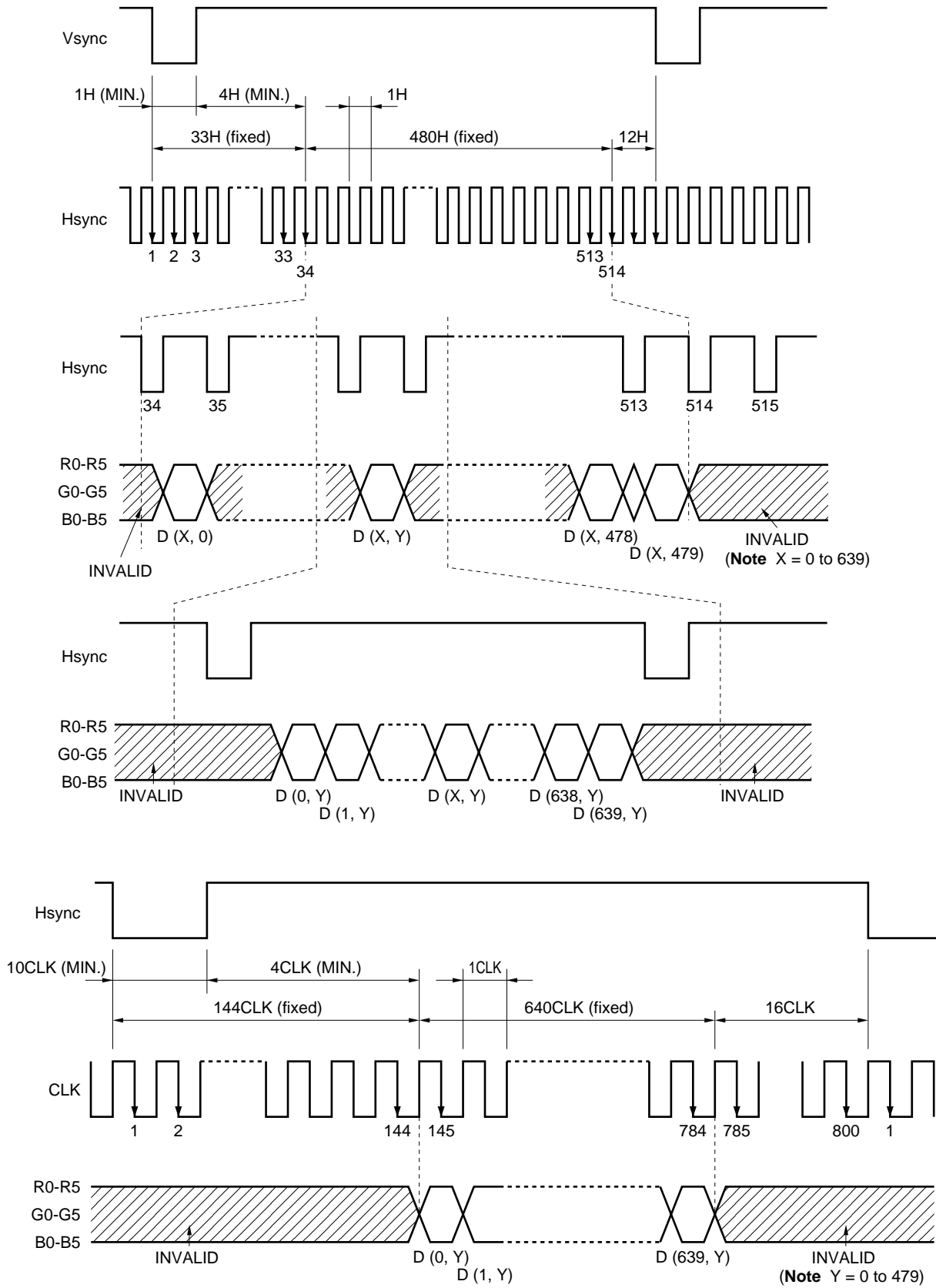

(b) DE mode

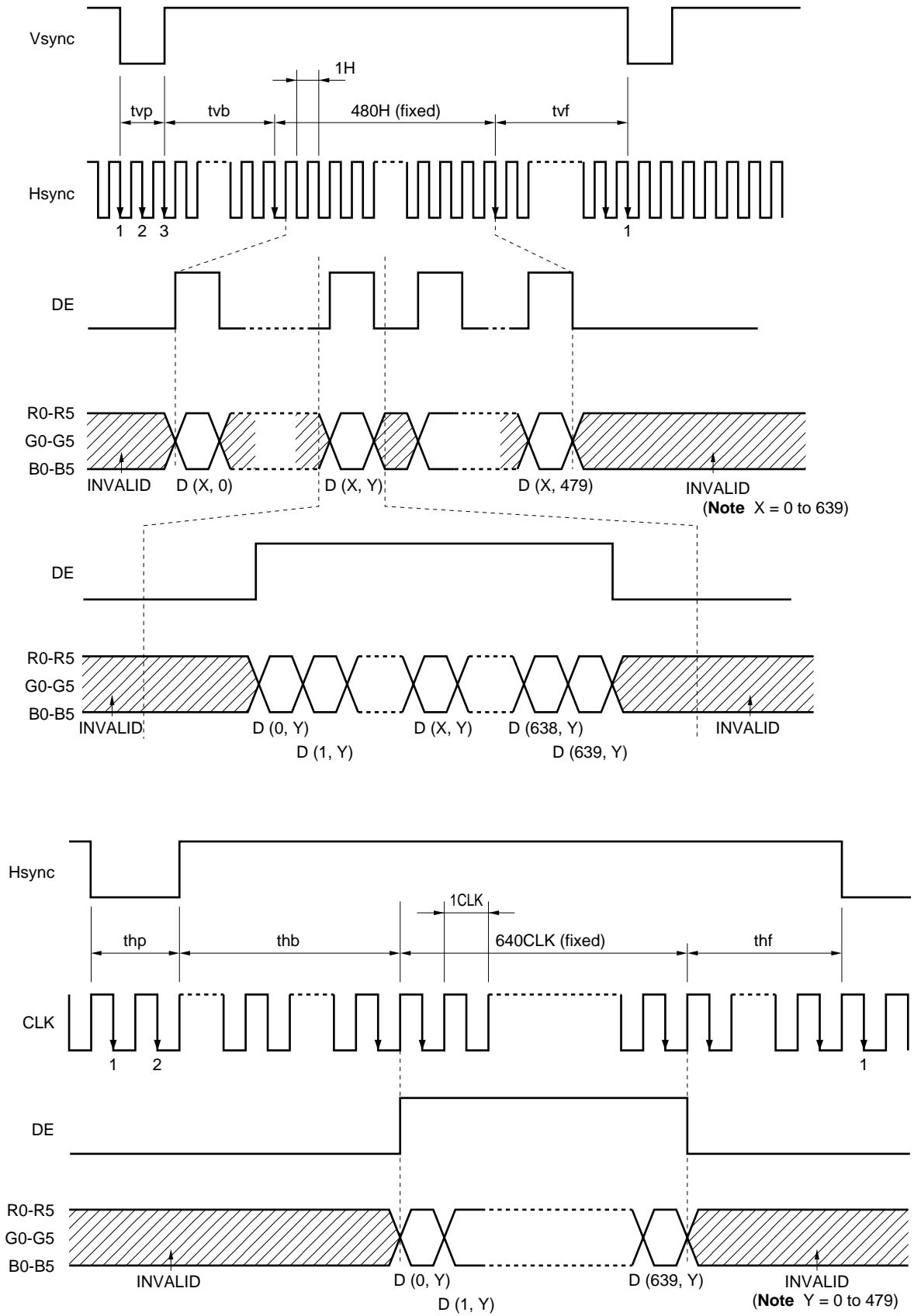

(4) Display position of input data

Normal scan (DPS = "GND" or "Open")

D (0, 0)	D (1, 0)	---	D (X, 0)	---	D (638, 0)	D (639, 0)
D (0, 1)	D (1, 1)	---	D (X, 1)	---	D (638, 1)	D (639, 1)
⋮	⋮	⋮	⋮	⋮	⋮	⋮
D (0, Y)	D (1, Y)	---	D (X, Y)	---	D (638, Y)	D (639, Y)
⋮	⋮	⋮	⋮	⋮	⋮	⋮
D (0, 478)	D (1, 478)	---	D (X, 478)	---	D (638, 478)	D (639, 478)
D (0, 479)	D (1, 479)	---	D (X, 479)	---	D (638, 479)	D (639, 479)

Reverse scan (DPS = "Vcc")

D (639, 479)	D (638, 479)	---	D (X, 479)	---	D (1, 479)	D (0, 479)
D (639, 478)	D (638, 478)	---	D (X, 478)	---	D (1, 478)	D (0, 478)
⋮	⋮	⋮	⋮	⋮	⋮	⋮
D (639, Y)	D (638, Y)	---	D (X, Y)	---	D (1, Y)	D (0, Y)
⋮	⋮	⋮	⋮	⋮	⋮	⋮
D (639, 1)	D (638, 1)	---	D (X, 1)	---	D (1, 1)	D (0, 1)
D (639, 0)	D (638, 0)	---	D (X, 0)	---	D (1, 0)	D (0, 0)

Notes 1. Below drawings show relations between the scan direction and the viewing direction.

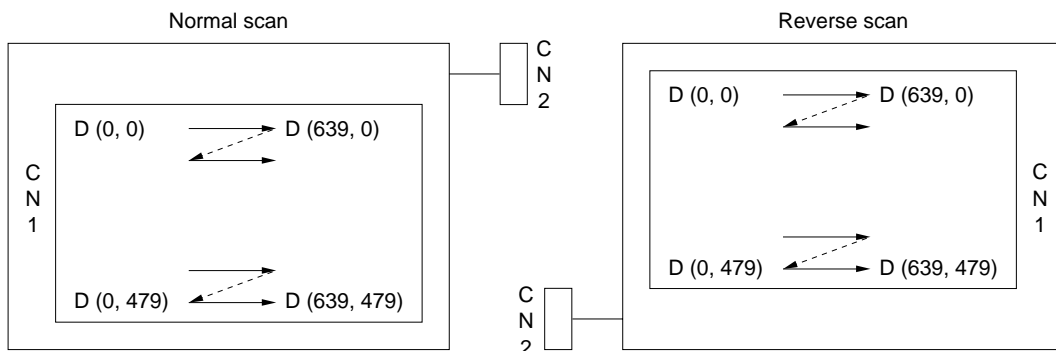

2. When DPS is open or low, the scan direction is set up by the switch (SW1) on the rear side.

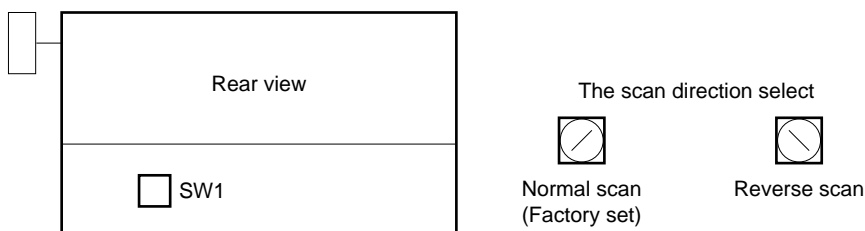

See (1) Interface signals, power supply (Note 5) about another way for reversible scan. When DPS is High, reverse scan is selected even if SW1 is set at normal scan.



**OPTICAL CHARACTERISTICS**

T<sub>a</sub> = 25 ± 5°C, V<sub>CC</sub> = 3.3 V V<sub>DD</sub>B = 12 V, MAV = V<sub>CC</sub> or open, at normal scan

Parameters	Symbols	Conditions	MIN.	TYP.	MAX.	Unit	Remarks
Contrast ratio	CR	θX = ±0°, θY = ±0°, at center	150	300	–	–	<b>Note 1</b>
Luminance	L VMAX	θX = ±0°, θY = ±0°, at center	280	350	–	cd/m <sup>2</sup>	<b>Note 2</b>
Luminance uniformity	–	max. /min.	–	1.25	1.40	–	<b>Note 3</b>

Reference data

Parameters	Symbols	Conditions	MIN.	TYP.	MAX.	Unit	Remarks	
Viewing angle range	Horizontal	θX+	CR > 10, θY = ±0° (CR > 5)	45 –	50 (60)	– –	deg.	<b>Note 4</b>
		θX–	CR > 10, θY = ±0° (CR > 5)	45 –	50 (60)	– –	deg.	
	Vertical	θY+	CR > 10, θX = ±0° (CR > 5)	35 –	40 (50)	– –	deg.	
		θY–	CR > 10, θX = ±0° (CR > 5)	40 –	45 (55)	– –	deg.	
Response time	t on	White to black	–	15	40	ms	<b>Note 5</b>	
	t off	Black to white	–	70	85	ms		
Color gamut	C	At center. to NTSC	35	43	–	%	–	

**Notes 1.** The contrast ratio is calculated by using the following formula.

$$\text{Contrast ratio (CR)} = \frac{\text{Luminance with all pixels in white}}{\text{Luminance with all pixels in black}}$$

The Luminance is measured in darkroom.

- The luminance is measured after 20 minutes from the module works, with all pixels in white. Typical value is measured after luminance saturation.

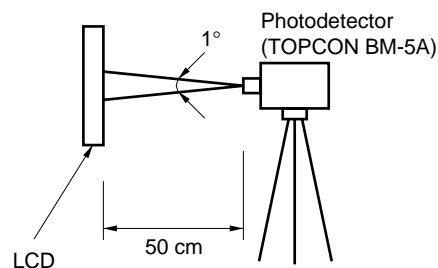

3. The luminance uniformity is calculated by using following formula.

$$\text{Luminance uniformity} = \frac{\text{Maximum luminance}}{\text{Minimum luminance}}$$

The luminance is measured at near the five points shown below.

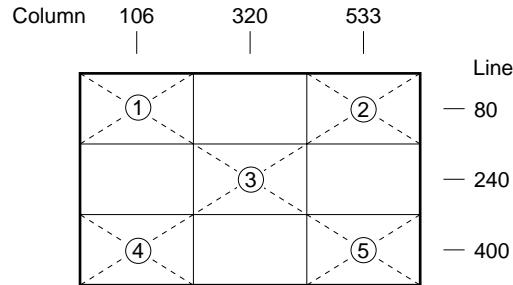

4. Definitions of viewing angle are as follows.

The viewing angles are reference.

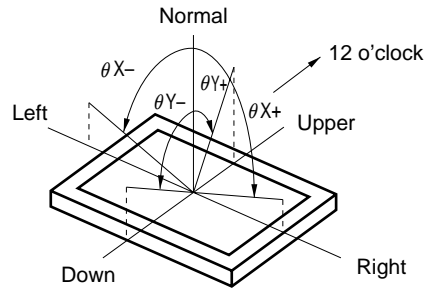

5. Definition of response time is as follows.

Photodetector output signal is measured when the luminance changes “White” to “Black” . Response time (ton) is the time between 10% and 100% of the photodetector output amplitude. Response time (toff) is the time between 0% and 90% of the output amplitude.

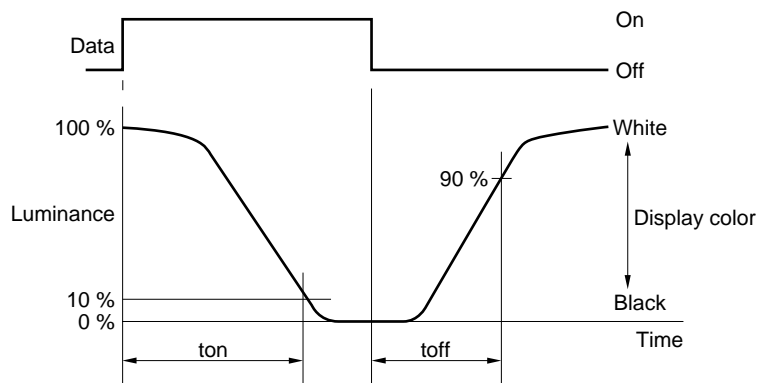

RELIABILITY TEST

Test items	Test conditions
High temperature/humidity operation <b>Note 1</b>	50 ± 2°C, 85% relative humidity 240 hours Display data is black.
Heat cycle (operation) <b>Note 1</b>	<1> 0°C ± 3°C ... 1 hour 55°C ± 3°C ... 1 hour <2> 50 cycles, 4 hours/cycle <3> Display data is black.
Thermal shock (non-operation) <b>Note 1</b>	<1> -20°C ± 3°C ... 30 minutes 60°C ± 3°C ... 30 minutes <2> 100 cycles <3> Temperature transition time within 5 minutes
Vibration (non-operation) <b>Notes 1, 2</b>	<1> 5 - 100 Hz, 2G 1 minute/cycle X, Y, Z direction <2> 120 times each direction
Mechanical shock (non-operation) <b>Notes 1, 2</b>	<1> 55 G, 11 ms X, Y direction 30G, 11 ms Z direction <2> 5 times each direction
ESD (operation) <b>Notes 1, 3</b>	150 pF, 150 Ω, ±10 kV 9 places on a panel 10 times each place at one-second intervals
Dust (operation) <b>Note 1</b>	15 kinds of dust (JIS Z 8901) Hourly 15 seconds stir, 8 times repeat

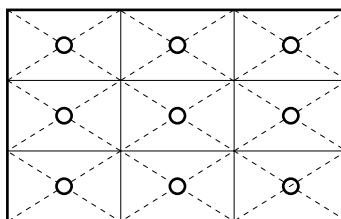

- Notes**
1. Display function is checked under the same condition as LCD module out-going inspection.
  2. Physical damage.
  3. Discharge points "O" are shown in the figure.



**GENERAL CAUTIONS**

Next figures and sentence are very important. Please understand these contents as follows.

	CAUTION This figure is a mark that you will get hurt and/or the module will have damages when you make a mistake to operate.
---	--

	This figure is a mark that you will get an electric shock when you make a mistake to operate.
	This figure is a mark that you will get hurt when you make a mistake to operate

 CAUTIONS

	Do not touch an inverter, on which is stuck a caution label, while the LCD module is under the operation, because of dangerous high voltage.
---	--

- (1) Caution when taking out the module
  - a) Pick the pouch only, when taking out the module from a carrier box.
- (2) Cautions for handling the module
  - a) As the electrostatic discharges may break the LCD module, handle the LCD module with care against electrostatic discharges.
  - b)  As the LCD panel and backlight element are made from fragile glass material, impulse and pressure to the LCD module should be avoided.
  - c) As the surface of polarizer is very soft and easily scratched, use a soft dry cloth without chemicals for cleaning.
  - d) Do not pull the interface connectors in or out while the LCD module is operating.
  - e) Put the module display side down on a flat horizontal plane.
  - f) Handle connectors and cables with care.
  - g) When the module is operating, do not lose CLK, Hsync or Vsync signal. If any one or more of these signals is lost, the LCD panel would be damaged.
  - h) The torque for mounting screws should never exceed 0.294 N·m (3 kgf·cm).
- (3) Cautions for the atmosphere
  - a) Dew drop atmosphere must be avoided.
  - b) Do not store and/or operate the LCD module in high temperature and/or high humidity atmosphere. Storage in an electro-conductive polymer packing pouch and under relatively low temperature atmosphere is recommended.
  - c) This module uses cold cathod fluorescent lamps. Therefore, the life time of lamp becomes short conspicuously at low temperature.
  - d) Do not operate the LCD module in high magnetic field.
- (4) Cautions for the module characteristics
  - a) Do not apply any fixed patterns data signal for a long time to the LCD module at product aging. It may cause image sticking.
  - b) This module has the retardation film which may cause the variation of color hue in the different viewing angles. The ununiformity may appear on the screen under the high temperature operation.

## (5) Other cautions

- a) Do not disassemble and/or reassemble LCD module.
- b) Do not readjust variable resistors nor switches etc.
- c) When returning the module for repair or etc, please pack the module not to be broken. We recommend the original shipping packages.

Liquid Crystal Display has the following specific characteristics. There are not defects nor malfunctions.

- The display condition of the LCD module may be affected by the ambient temperature.
- The LCD module uses cold cathode tube for backlighting. Optical characteristics, like luminance or uniformity, will change during time.
- Uneven brightness and/or small spots may be noticed depending on different display patterns.

OUTLINE DRAWING: Front View (Unit: mm)

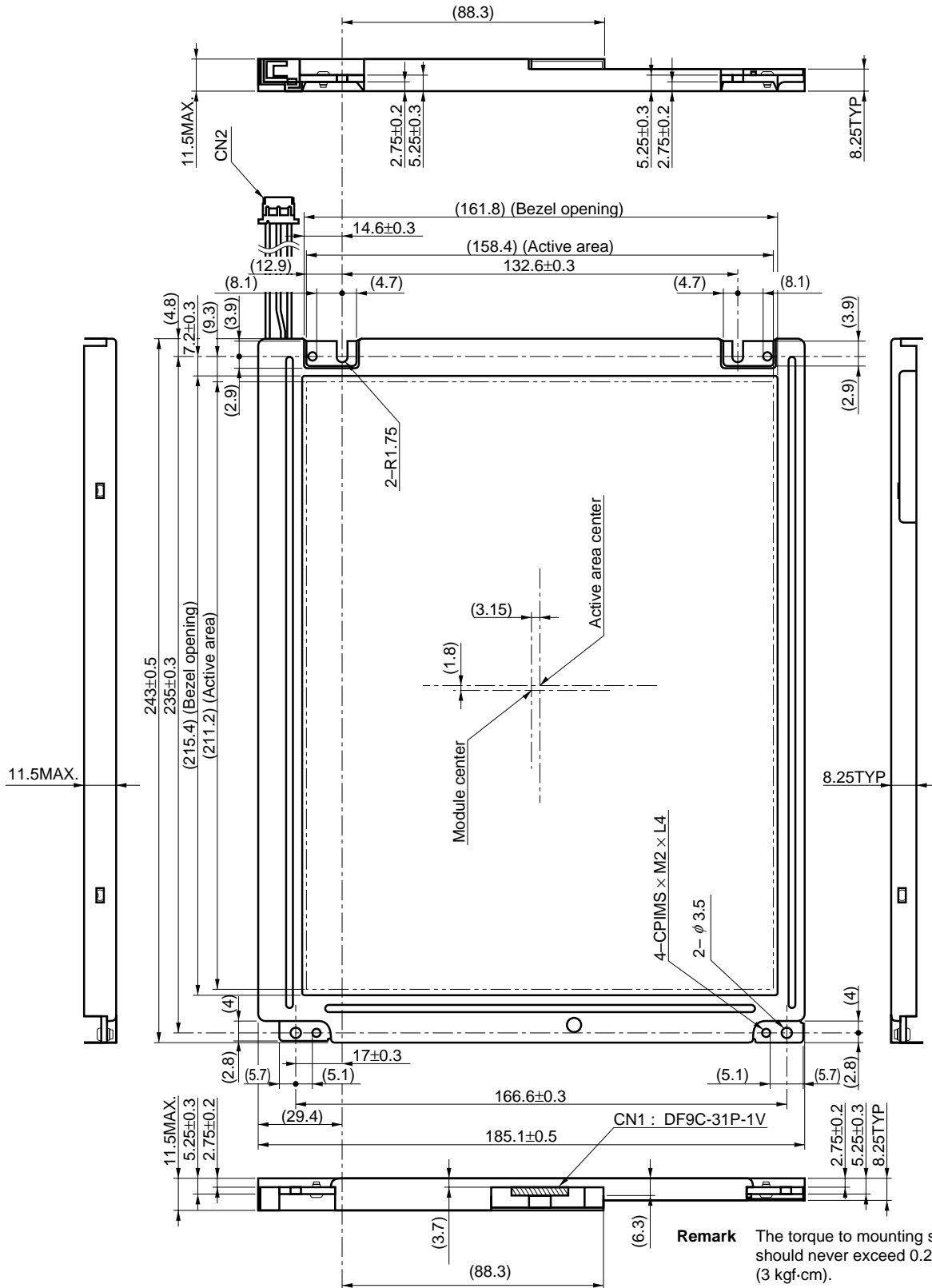

OUTLINE DRAWING: Rear View (Unit: mm)

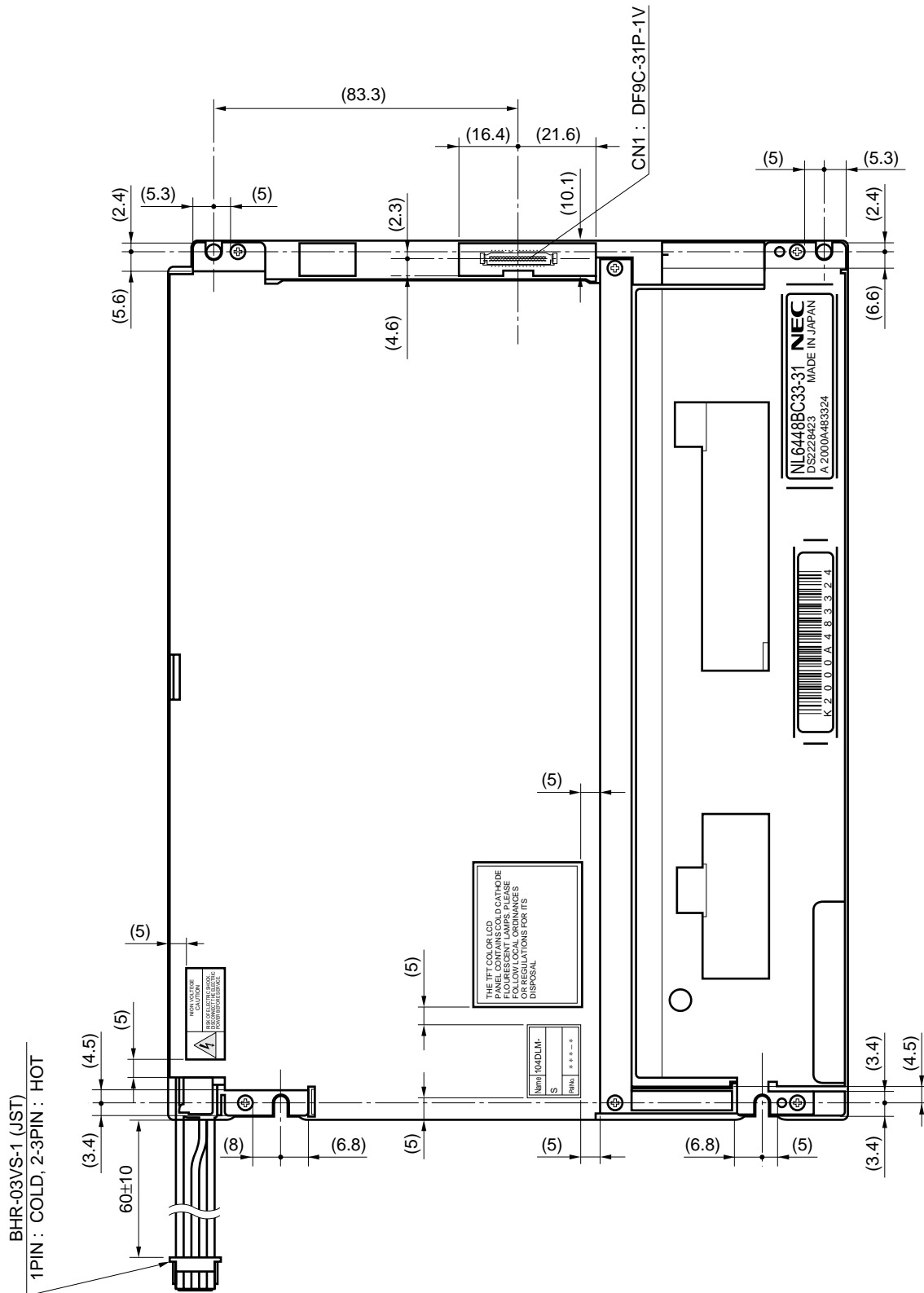

No part of this document may be copied or reproduced in any form or by any means without the prior written consent of NEC Corporation. NEC Corporation assumes no responsibility for any errors which may appear in this document.

NEC Corporation does not assume any liability for infringement of patents. Copyrights or other intellectual property rights of third parties by or arising from use of a device described herein or any other liability arising from use of such device. No license, either express, implied or otherwise, is granted under any patents, copyrights or other intellectual property rights of NEC Corporation or others.

While NEC Corporation has been making continuous effort to enhance the reliability of its Electronic Components, the possibility of defects cannot be eliminated entirely. To minimize risks of damage or injury to persons or property arising from a defect in an NEC Electronic Components, customers must incorporate sufficient safety measures in its design, such as redundancy, fire-containment, and anti-failure features.

NEC devices are classified into the following three quality grades:

“Standard”, “Special”, and “Specific”. The Specific quality grade applies only to devices developed based on a customer designated “quality assurance program” for a specific application. The recommended applications of a device depend on its quality grade, as indicated below. Customers must check the quality grade of each device before using it in a particular application.

Standard: Computers, office equipment, communications equipment, test and measurement equipment, audio and visual equipment, home electronic appliances, machine tools, personal electronic equipment and industrial robots

Special: Transportation equipment (automobiles, trains, ships, etc.), traffic control systems, anti-disaster systems, anti-crime systems, safety equipment and medical equipment (not specifically designed for life support)

Specific: Aircrafts, aerospace equipment, submersible repeaters, nuclear reactor control systems, life support systems or medical equipment for life support, etc.

The quality grade of NEC devices is “Standard” unless otherwise specified in NEC’s Data Sheets or Data Books. If customers intend to use NEC devices for applications other than those specified for Standard quality grade, they should contact an NEC sales representative in advance.

Anti-radioactive design is not implemented in this product.