

VICOR CONFIDENTIAL
 THIS DOCUMENT AND THE DATA CONTAINED HEREIN OR HEREWITH IS NOT TO BE REPRODUCED, USED, OR DISCLOSED IN WHOLE OR IN PART TO ANYONE WITHOUT PERMISSION OF VICOR CORP.

REV	DESCRIPTION	DATE	APPROVED	
P3	84-40 1.90 WAS 1.83 S	UPK	4/22/97	SWN
#6	REVISED NOTE 1	DPK	9/25/97	SWN
#7	REVISED NOTES. ADDED FRONT VIEW. FORMAT WAS 'B' SIZE. TAP DEPTH WAS .520	DPK	9/30/97	SWN
#8	TWO PLACE DIMS WERE THREE	UPK	10/10/97	SWN
#9	ADDED .010 TO DIM 2.220 WAS 2.200	DPK	12/8/97	SWN
#A	REMOVED P/N STAMPING NOTE 4	DPK	8/26/98	SWN
#B	ADDED NOTE 4. CRITICAL CHA. 'C'	AK	10/7/99	SWN

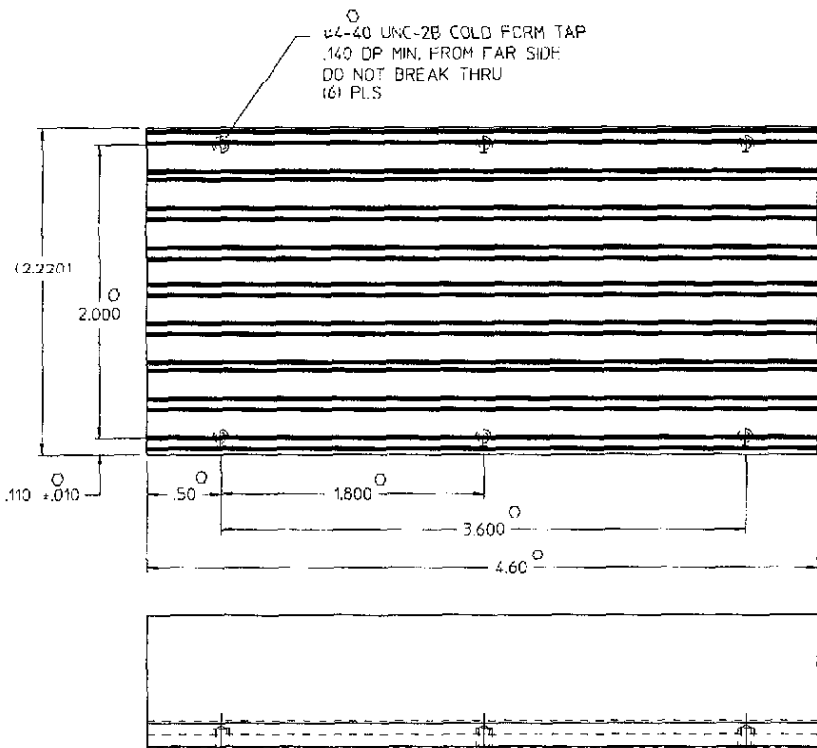

- NOTES
1. MAKE FROM VICOR EXTRUSION P/N 15948.
 2. REMOVE ALL BURRS AND SHARP EDGES.
 3. FINISH: CLEAR CHROMATE.
 4. 'C' DENOTES CRITICAL CHARACTERISTIC FOR LOT INSPECTION.

COPY

ORIGINAL ONLY WHEN STAMPED BY MED

<table border="1"> <tr> <td>GRABBY</td> <td>DATE</td> </tr> <tr> <td></td> <td>9/87</td> </tr> </table>	GRABBY	DATE		9/87		
GRABBY	DATE					
	9/87					
<small>UNLESS OTHERWISE SPECIFIED DIMENSIONS ARE IN INCHES DECIMALS: FRACTIONS: ANGLES: TYPICAL: UNLESS OTHERWISE SPECIFIED</small>	HTSNA "A" LONG .9H LOW FLOW, THREADED					
<small>THIRD ANGLE PROJECTION</small> 	SIZE: C 87131	UNSG NO: 15975				
<small>DO NOT SCALE DRAWING</small>	SCALE: 2:1	REV: # B SHEET 1 OF 1				