

Description

The AUK 60C31/P 60C51/P is a high-performance micro controller fabricated with AUK high-density CMOS technology. The AUK CMOS technology combines the high speed and density characteristics of MOS with the low power attributes of CMOS.

The 60C51 contains a 4K x 8 ROM, a 128 x 8 RAM, 32 I/O lines, two 16-bit counter/timers, a five-source, two-priority level nested interrupt structure, a serial I/O port for either multi-processor communication, I/O expansion or full duplex UART, and on-chip oscillator and clock circuits.

In addition, the device has two software selectable modes of power reduction idle mode and power-down mode. The idle mode freezes the CPU while allowing the RAM, timers, serial port, and interrupt system to continue functioning.

Features

- 8-bit CPU optimized for control applications.
- Pin-to-pin compatible with intel's 80C51/80C31.
- 60C51 low power mask programmable ROM
- 64K Program Memory Space, Data Memory space
- 32K programmable I/O lines.
- High performance CMOS process.
- 2 Level programmable serial port
- Power control modes.
- 60C31 low power CPU only
- Two 16bit timer/counters
- 5 interrupt sources.
- 3.5 to 12MHz @ 5V ± 20%

Ordering Information

Type NO.	Marking	Package Code	Type NO.	Marking	Package Code
SD60C31	SD60C31	PLCC44	SD60C31P	SD60C31	DIP40
SD60C51	SD60C51	PLCC44	SD60C51P	SD60C51	DIP40

Outline Dimensions

unit : mm

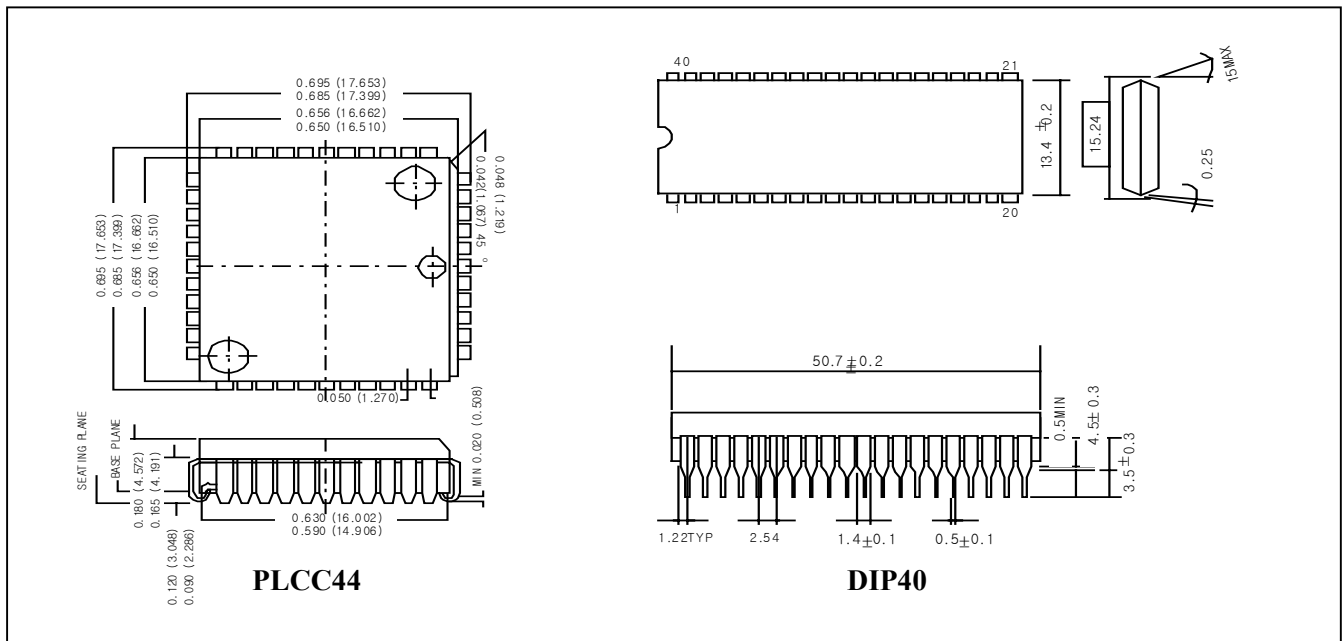

Absolute Maximum Ratings

Characteristic	Rating	Unit
Ambient temperature under bias	0 ~ +70	°C
Storage temperature	-65 ~ +150	°C
Voltage on any pin to Vss	-0.5~Vcc + 0.5	V
Maximum I _{OL} per I/O pin	15	mA
Power dissipation	1	Watt

Block Diagram

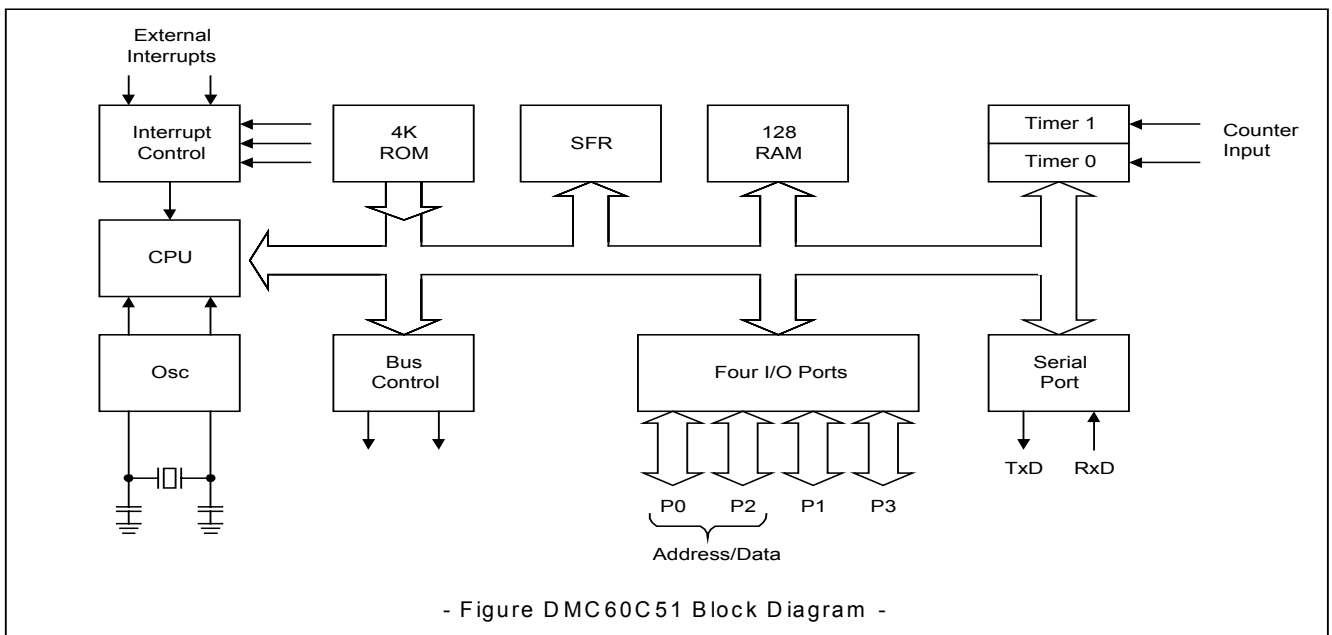

Description

The AUK 60C31/P 60C51/P is a high-performance micro controller fabricated with AUK high-density CMOS technology. The AUK CMOS technology combines the high speed and density characteristics of MOS with the low power attributes of CMOS.

The 60C51 contains a 4K×8 ROM, a 128×8 RAM, 32I/O lines, two 16-bit counter/timers, a five-source, two-priority level nested interrupt structure, a serial I/O port for either multi-processor communication, I/O expansion or full duplex UART, and on-chip oscillator and clock circuits.

In addition, the device has two software selectable modes of power reduction idle mode and powerdown mode. The idle mode freezes the CPU while allowing the RAM, times, serial port, and interrupt system to continue functioning.

Pin Configuration

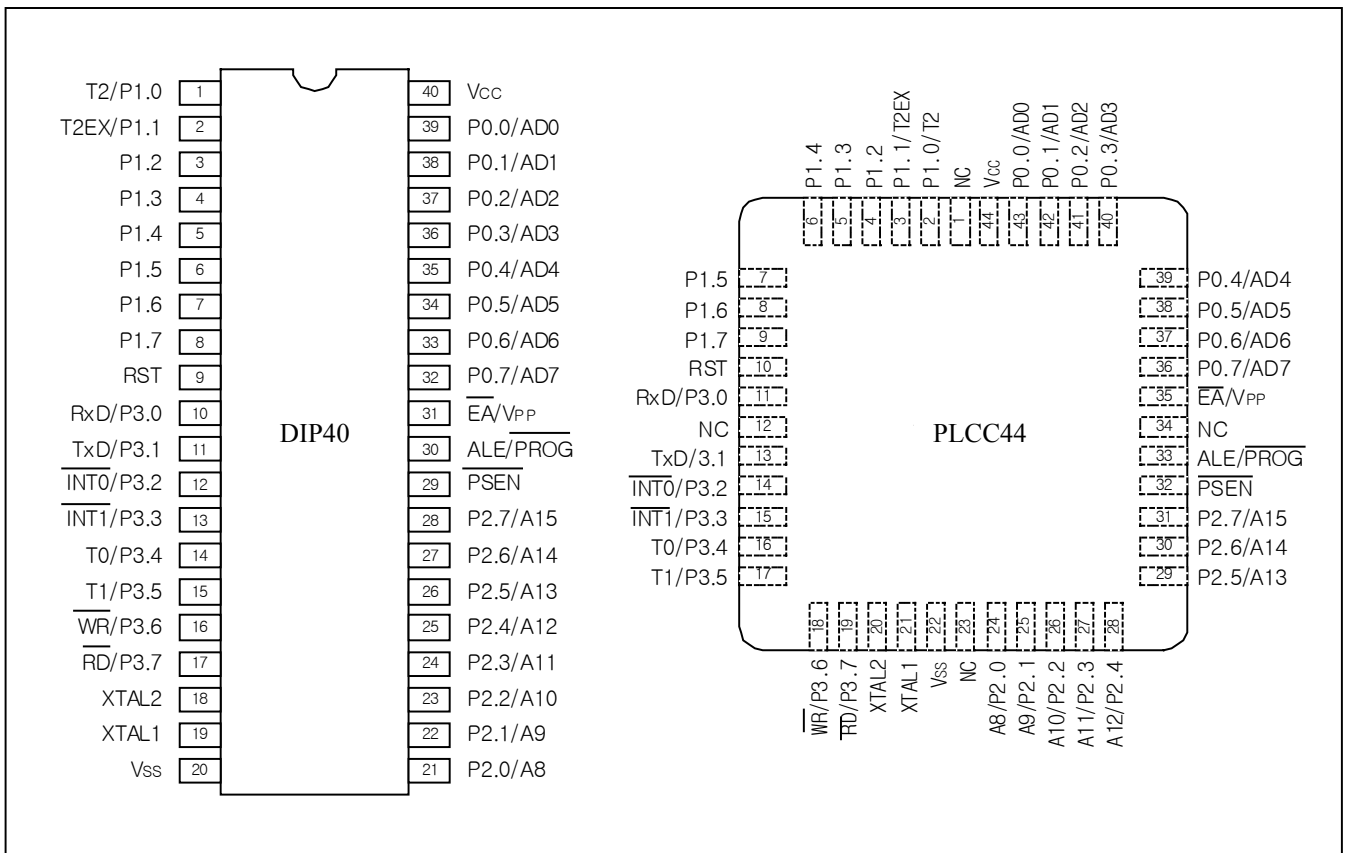

Pin Description

V_{CC} : PIN 40 (DIP40), PIN 44 (PLCC44)

Supply voltage during normal, Idle and power down operations.

V_{SS} : PIN 20 (DIP40), PIN 22 (PLCC44)

Circuit ground.

Port 0 : PIN 32~39 (DIP40), PIN 36~43 (PLCC44)

Port 0 is an 8bit open drain bi-directional I/O port. Port 0 pins that have 1's written to the them float, and in that state can be used as high impedance inputs. Port 0 is also the multiplexed low-order address and data bus during accesses to external program and data memory.

In this application it uses strong internal pullups when emitting 1's.

Pin Description(continued)

Port 1 : PIN 1~8 (DIP40), PIN 2~9 (PLCC44)

Port 1 is an 8-bit bi-directional I/O port with internal pullups.

Port 1 pins that have 1's written to them are pulled high by the internal pullups, and in that state can be used as inputs. As inputs, Port 1 pins that are externally being pulled low will source current because of the internal pullups.

Port 2 : PIN 21~28 (DIP40), PIN 24~31 (PLCC44)

Port 2 is an 8-bit bi-directional I/O port with internal pullups. Port 2 pins that have 1's written to them are pulled high by the internal pullups, and in that state can be used as inputs. As inputs, Port 2 pins that are externally being pulled low will source current because of the internal pullups.

Port 2 emits the high-order address byte during fetches from external Program Memory and during accesses to external Data Memory that use 16-bit addresses (MOVX @ DPTR). In this application it uses strong internal pullups when emitting 1's. During accesses to external data memory that use 8-bit addresses (MOVX @ Ri), Port 2 emits the contents of the P2 Special Function Register

Port 3 : PIN 10~17 (DIP40), PIN 13~19 (PLCC44)

Port 3 is an 8-bit bi-directional I/O port with internal pullups. Port 3 pins that have 1's written to them are pulled high by the internal pullups, and in that state can be used as inputs. As inputs, Port 3 pins that are externally being pulled low will source current because of the pullups.

Port 3 also serves the function of various special feature of the MCS-51 Family, as listed below :

Port PIN	PIN NO.	Alternate Function
P3.0	<u>10</u>	RxD (Serial input port)
P3.1	11	TxD (Serial output port)
P3.2	12	INT0 (external interrupt 0)
P3.3	13	INT1 (external interrupt 1)
P3.4	14	T0 (Timer 0 external input)
P3.5	15	T1 (Timer 1 external input)
P3.6	16	WR (external data memory write strobe)
P3.7	17	RD (external data memory read strobe)

RST : PIN 9 (DIP40), PIN 10 (PLCC44)

Reset input. A high on this pin for two machine cycles while the oscillator is running resets the device. An internal diffused resistor to V_{SS} permits Power-On reset using only an external capacitor to V_{CC} .

Pin Description(continued)

ALE : PIN 30 (DIP40), PIN 33 (PLCC44)

Address latch enable output pulse for latching the low byte of the address during accesses to external memory.

In normal operation ALE is emitted at a constant rate of 1/6 the oscillator frequency, and may be used for external timing of clocking purposes.

Note : However, that one ALE pulse is skipped during each access to external data memory.

If desired, ALE operation can be disabled by setting bit 0 of SFR location 8EH.

With the bit set, ALE is active only during a MOVX instruction. Otherwise, the pin is weakly pulled high.

$\overline{\text{PSEN}}$: PIN 29 (DIP40), PIN 32 (PLCC44)

Program store enable is the read strobe to external program memory. When the 60C51 is executing code from external program memory, $\overline{\text{PSEN}}$ is activated twice each machine cycle, except that two $\overline{\text{PSEN}}$ activations are skipped during each access to external data memory. $\overline{\text{PSEN}}$ is not activated during fetches from internal program memory.

$\overline{\text{EA}}$: PIN 31 (DIP40), PIN 35 (PLCC44)

External access enable. $\overline{\text{EA}}$ must be strapped to V_{SS} in order to enable the device to fetch code from external program memory locations starting at 0000H up to FFFFH.

If $\overline{\text{EA}}$ is strapped to V_{CC} the device executes from internal program memory unless the program counter contains an address greater than 0FFFH.

XTAL1 : PIN 19 (DIP40), PIN 21 (PLCC44)

Input to the inverting oscillator amplifier and input to the internal clock generator circuits.

NC : PIN1, 12, 23, 34 (PLCC44)

Non connection pins.

XTAL2 : PIN 18 (DIP40), PIN 20(PLCC44)

Output from the inverting oscillator amplifier

Pin Description(continued)

- Crystal oscillator

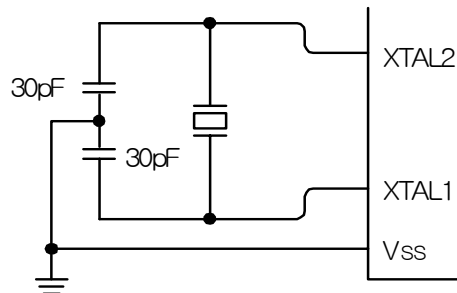

Idle Mode

In the Idle mode, the CPU puts itself to sleep while all the on chip peripherals stay active. The instruction that invokes the Idle mode is the last instruction executed in the normal operating mode before Idle mode is activated.

The content of the on-chip RAM and all the special function registers remain intact during this mode. The Idle mode can be terminated either by any enabled interrupt, at which time the process is picked up at the interrupt service routine and continued, or by a hardware reset which starts the processor the same as a power on reset.

Power Down Mode

In the power down mode the oscillator is stopped, and the instruction that invokes power down is the last instruction executed. The on-chip RAM and special function register retain their values until the power down mode is terminated.

The only exit from power down is a hardware reset. Reset redefines the SFRs but does not change the on-chip RAM. The reset should not be activated before V_{CC} is restored to its normal operating level and must be held active long enough to allow the oscillator to restart and stabilize.

The control bits for the reduced power modes are in the special function register PCON.

Table Status of the external pins during Idle and power down modes.

Mode	Program memory	ALE	PSEN	PORT 0	PORT 1	PORT 2	PORT 3
Idle	Internal	1	1	Data	Data	Data	Data
Idle	External	1	1	Float	Data	Address	Data
Power down	Internal	0	0	Data	Data	Data	Data
Power down	External	0	0	Float	Data	Data	Data

Electrical Characteristics(DC)

($T_A = 0^\circ\text{C} \sim 70^\circ\text{C}$ or $-40^\circ\text{C} \sim 85^\circ\text{C}$, $V_{CC} = 5\text{V} \pm 20\%$, $V_{SS}=0\text{V}$)

SYMBOL	PARAMETER	TEST CONDITIONS	LIMITS			UNIT
			MIN	TYP.	MAX	
V_{IL}	Input low voltage, except \overline{EA}		-0.5		$0.2V_{CC}-0.1$	V
V_{ILI}	Input low voltage to \overline{EA}		0		$0.2V_{CC}-0.3$	V
V_{IH}	Input high voltage, except XTAL1,RST		$0.2V_{CC}+0.9$		$V_{CC}+0.5$	V
V_{IHI}	Input high voltage to XTAL1, RST		$0.7 V_{CC}$		$V_{CC}+0.5$	V
V_{OL}	Output low voltage to ports 1,2,3	$I_{OL}=1.6\text{ mA}$			0.45	V
V_{OLI}	Output low voltage to ports 0, ALE, PSEN	$I_{OL}=3.2\text{ mA}$			0.45	V
V_{OH}	Output high voltage to ports 1,2,3,ALE,PSEN	$I_{OH}=-60\ \mu\text{A}$ $I_{OH}=-25\ \mu\text{A}$ $I_{OH}=-10\ \mu\text{A}$	2.4 $0.75V_{CC}$ $0.9V_{CC}$			V
V_{OHI}	Output high voltage (port 0 in external bus mode)	$I_{OH}=-800\ \mu\text{A}$ $I_{OH}=-300\ \mu\text{A}$ $I_{OH}=-80\ \mu\text{A}$	2.4 $0.75V_{CC}$ $0.9V_{CC}$			V
I_{IL}	Logical 0 input current to ports 1,2,3	$V_{IN}=0.45\text{V}$			-50	μA
I_{TL}	Logical 1 to 0 transition current to port 1,2,3	$V_{IN}=2\text{V}$			-650	μA
I_{LI}	Input leakage current to port 0, \overline{EA}	$0.45 < V_{IN} < V_{CC}$			± 10	μA
I_{CC}	Power supply current Active mode @ 12MHz Idle mode @ 12MHz Power-down mode	See note1		11 1.7 5	20 5 50	mA mA μA
R_{RST}	Internal reset pull-down resistor		50		150	kohm
C_{I0}	Pin capacitance				10	pF

Note : 1. See figure 8 through 11 for I_{CC} test conditions. Minimum V_{CC} for power down is 2V.

Electrical AC Characteristics(AC)

(T_A = 0°C or -40°C ~ 85°C, V_{CC} = 5V ± 20%, V_{SS}=0V)

SYM-BOL	FIGURE	PARAMETER	12MHz CLOCK		VARIABLE CLOCK		UNIT
			MIN	MAX	MIN	MAX	
1/t _{CLC_L}		Oscillator frequency : Speed versions 60C31/60C51			3.5	12	MHz
t _{LHLL}	1	ALE pulse width	127		2t _{CLCL} -40		ns
t _{AVLL}	1	Address valid to ALE low	28		t _{CLCL} -55		ns
t _{LLAX}	1	Address hold after ALE low	48		t _{CLCL} -35		ns
t _{LLIV}	1	ALE low to valid instruction in		234		4t _{CLCL} -100	ns
t _{LLPL}	1	ALE low to PSEN low	43		t _{CLCL} -40		ns
t _{PLPH}	1	PSEN pulse width	205		3t _{CLCL} -45		ns
t _{PLIV}	1	PSEN low to valid instruction in		145		3t _{CLCL} -105	ns
t _{PXIX}	1	Input instruction hold after PSEN	0		0		ns
t _{PXIZ}	1	Input instruction float after PSEN		59		t _{CLCL} -25	ns
t _{AVIV}	1	Address to valid instruction in		312		5t _{CLCL} -105	ns
t _{PLAZ}	1	PSEN low to address float		10		10	ns
Data Memory							
t _{RLRH}	2.3	RD pulse width	400		6t _{CLCL} -100		ns
t _{WLWH}	2.3	WR pulse width	400		6t _{CLCL} -100		ns
t _{RLDV}	2.3	RD low to valid data in		252		5t _{CLCL} -165	ns
t _{RHDX}	2.3	Data hold after RD	0		0		ns
t _{RHDZ}	2.3	Data float after RD		97		2t _{CLCL} -70	ns
t _{LLDV}	2.3	ALE low to valid data in		517		8t _{CLCL} -150	ns
t _{AVDV}	2.3	Address to valid data in		585		9t _{CLCL} -165	ns
t _{LLWL}	2.3	ALE low to RD or WR low	200	300	3t _{CLCL} -50	3t _{CLCL} +50	ns
t _{AVWL}	2.3	Address valid to WR low or RD low	203		4t _{CLCL} -130		ns
t _{QVWX}	2.3	Data valid to WR transition	23		t _{CLCL} -60		ns
t _{WHQZ}	2.3	Data hold after WR	33		t _{CLCL} -50		ns
t _{RLAZ}	2.3	RD low to address float		0		0	ns
t _{WHLH}	2.3	RD or WR high to ALE high	43	123	t _{CLCL} -40	t _{CLCL} +40	ns
External Clock							
t _{CHCX}	4	High time	20		20		ns
t _{CLCX}	4	Low time	20		20		ns
t _{CLCH}	4	Rise time		20		20	ns
t _{CHCL}	4	Fall time		20		20	ns

Timing Diagram

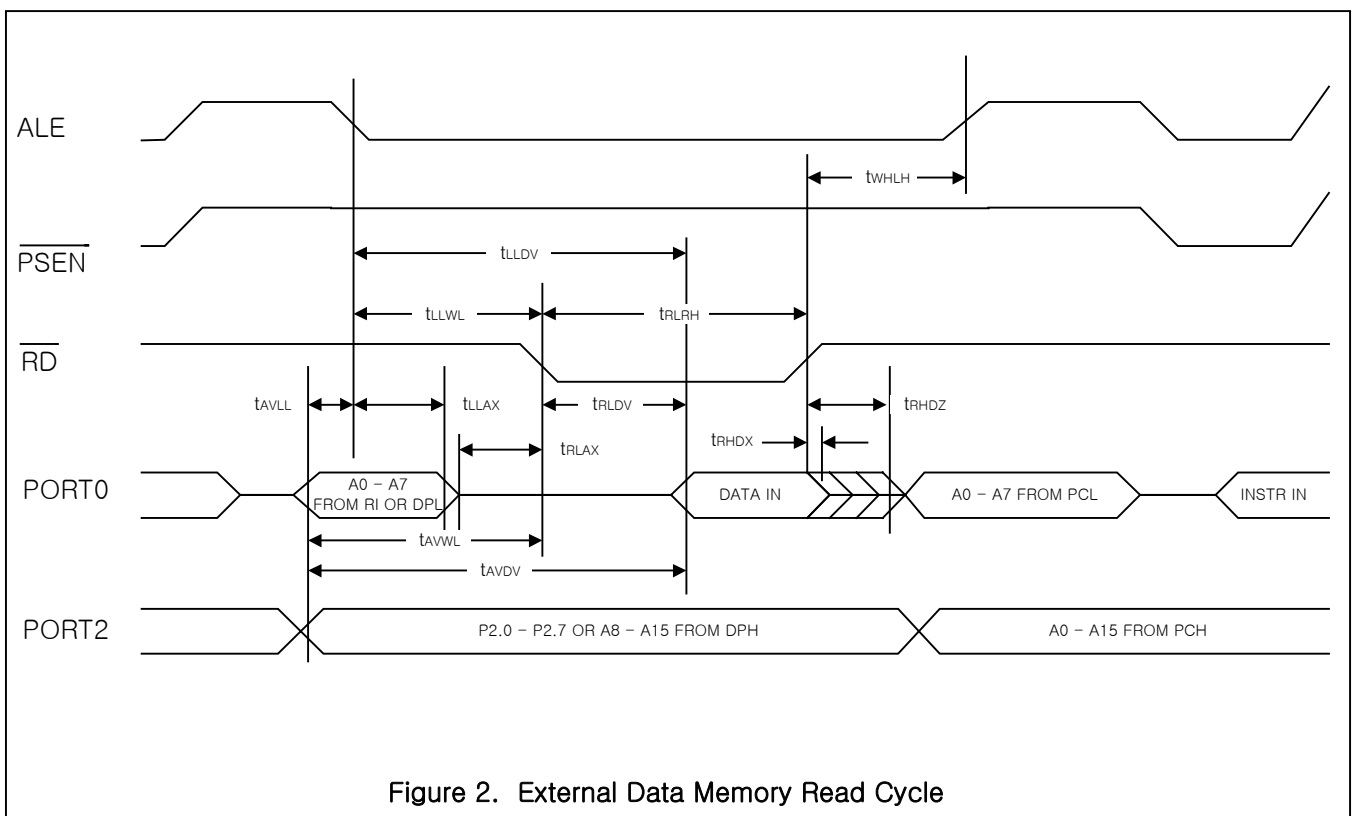
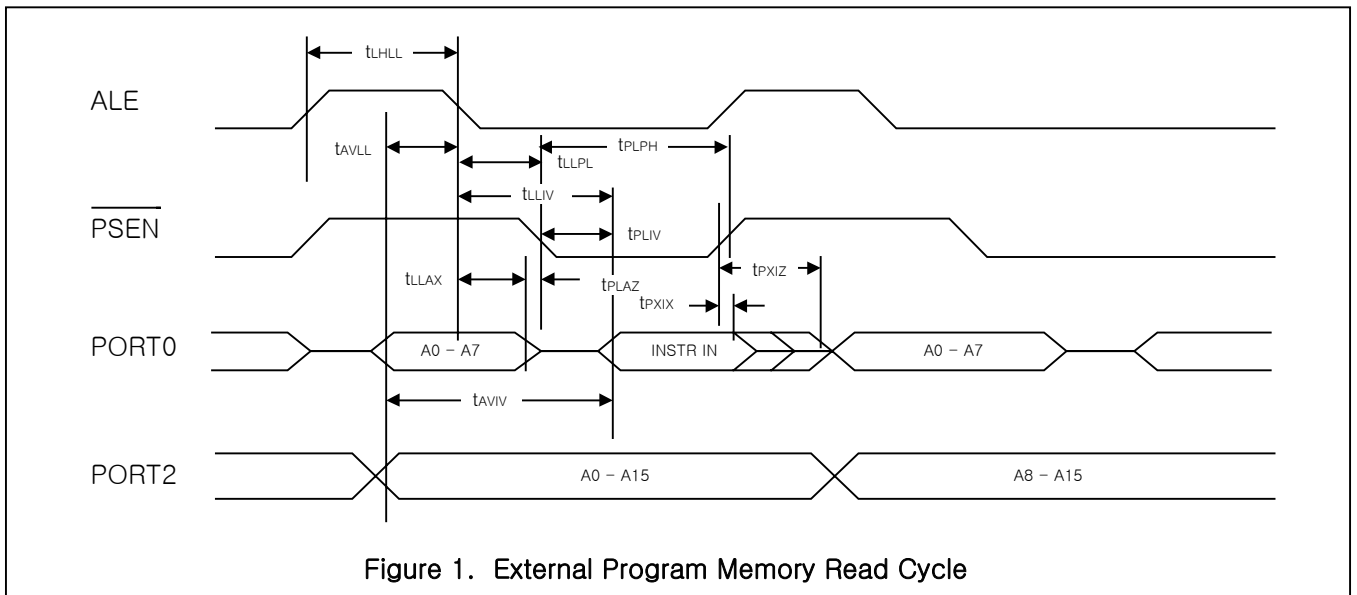

Timing Diagram(Continued)

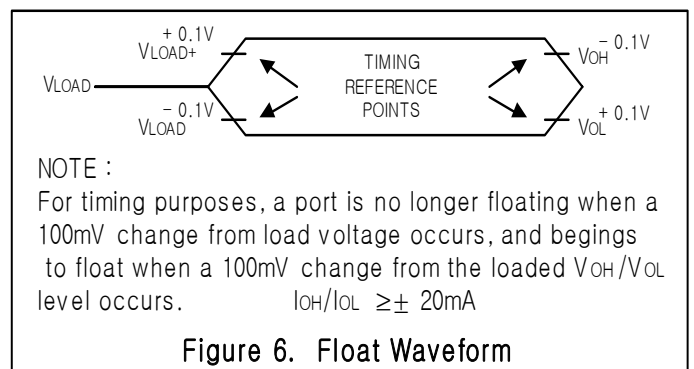
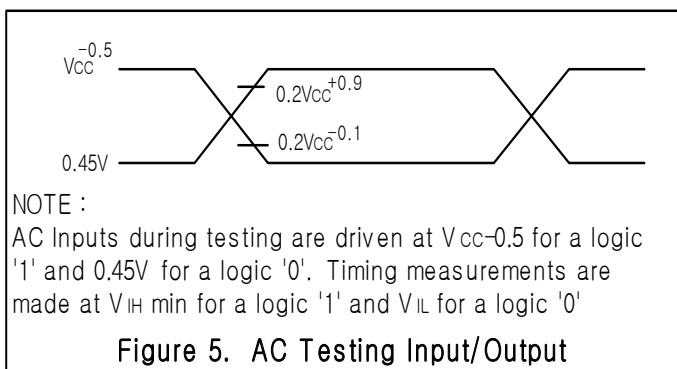
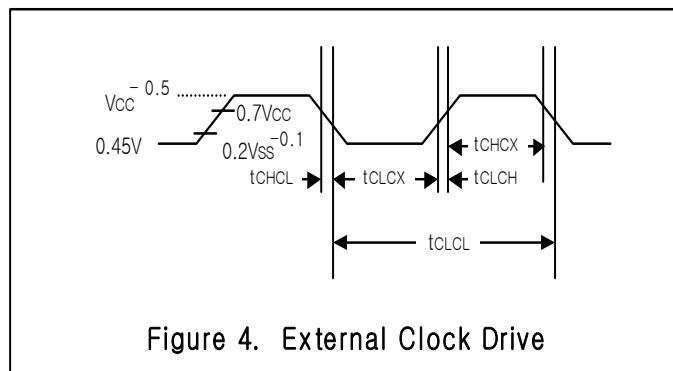
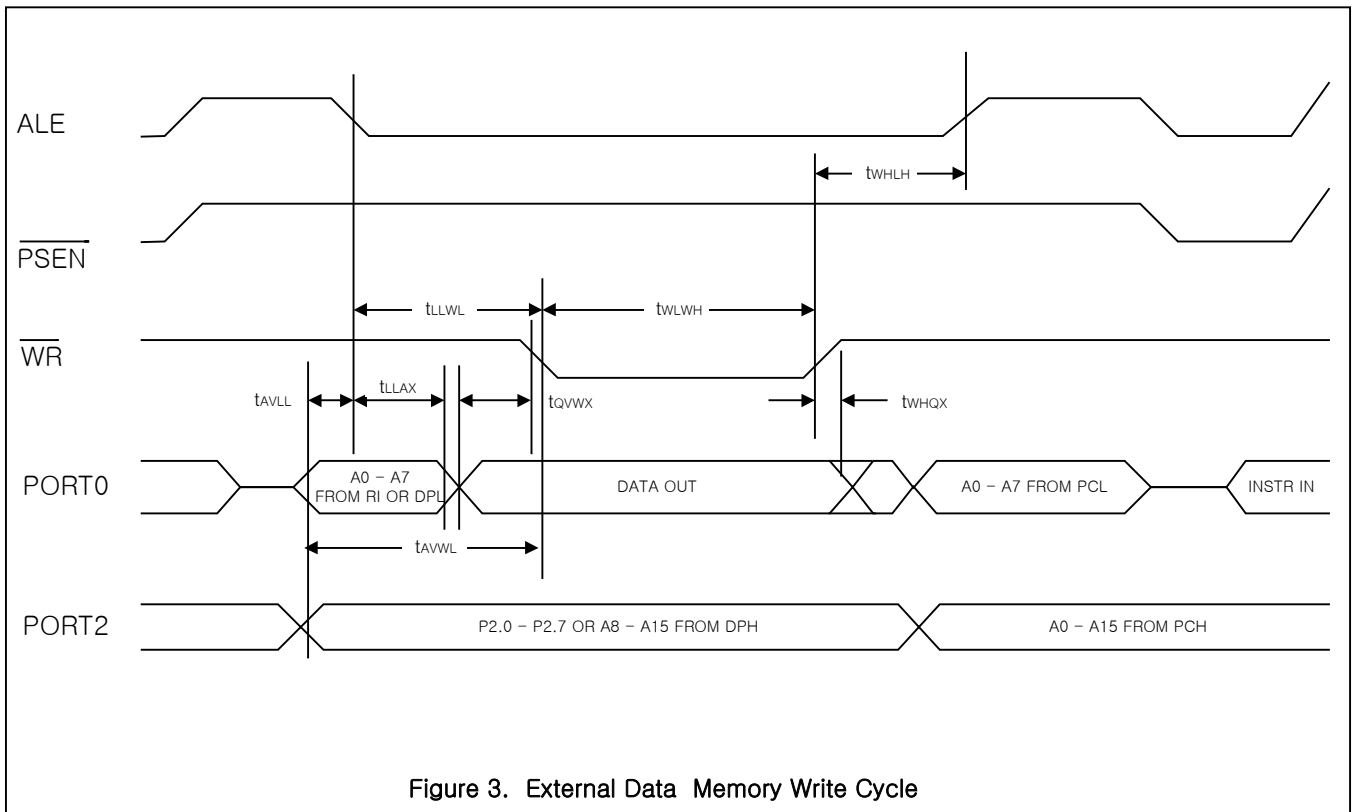

Timing Diagram(Continued)

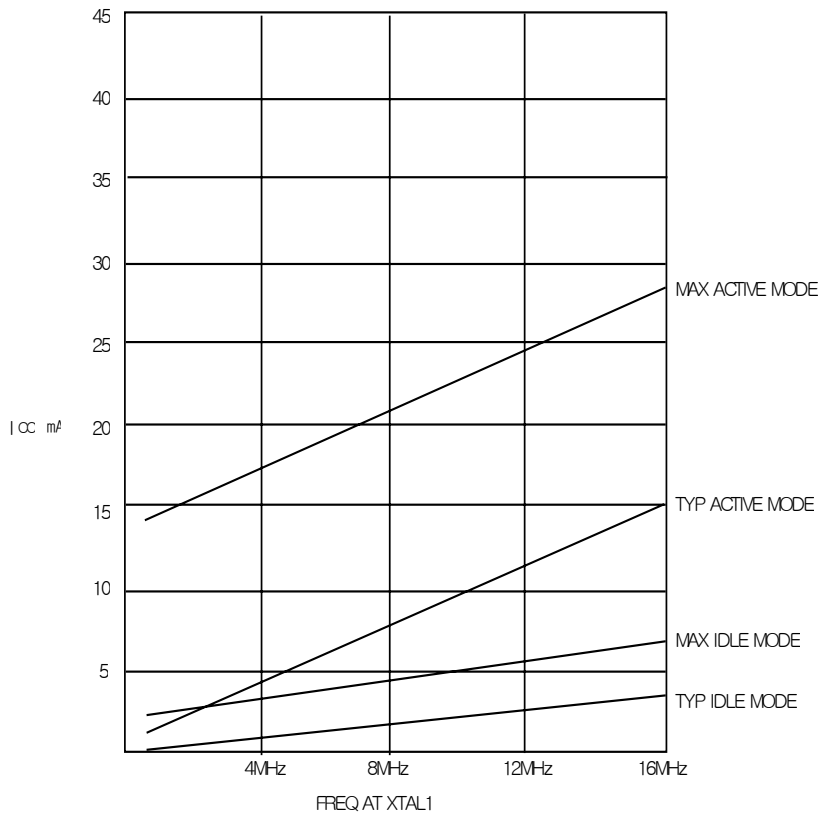

Figure 7. I_{CC} vs. FREQ

Valid only within frequency specifications of the device under test

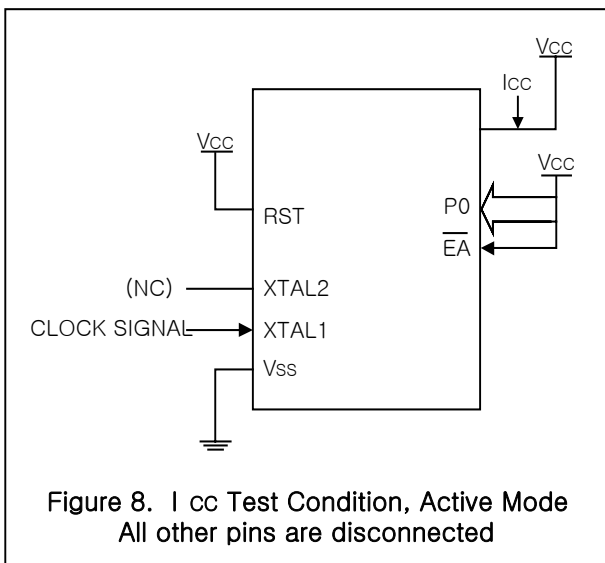

Figure 8. I_{CC} Test Condition, Active Mode
All other pins are disconnected

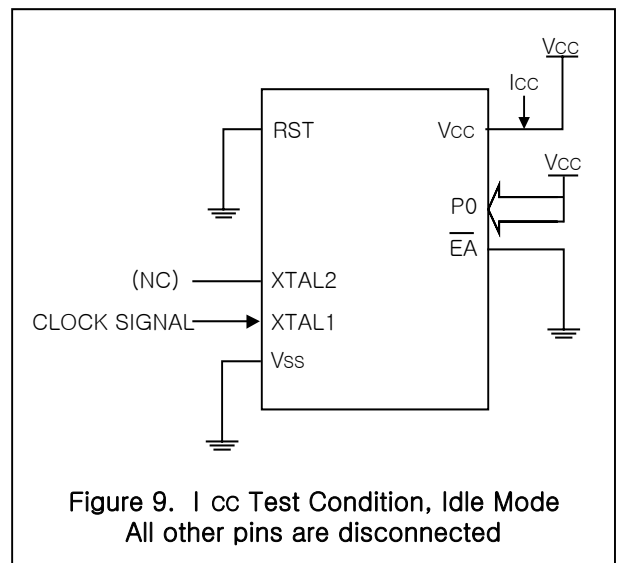

Figure 9. I_{CC} Test Condition, Idle Mode
All other pins are disconnected

Timing Diagram(Continued)

