

PRELIMINARY

DIGITAL TO ANALOG CONVERTER FOR STEREO AUDIO

■ GENERAL DESCRIPTION

The **NJU8402** is a 16-bit delta-sigma Digital-to-Analog Converter for stereo audio. It consists of Serial Audio Data Interface, Digital Interpolation Filter, $\Delta\Sigma$ Modulator, SC LPF, Buffer Amp, System Controller for status control. It operates on single +5V power supply. Furthermore, it accepts 16-bit input audio data length or 18-bit, and supports I²S serial data format and LSB justified.

Therefore, the **NJU8402** is suitable for CD, MD, DAT and other digital audio applications.

■ PACKAGE OUTLINE

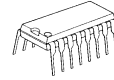

NJU8402D

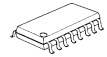

NJU8402M

■ FEATURES

- $\Delta\Sigma$ type 1bit stereo DAC
- Sample Rate (fs) : 50kHz (Maximum)
- Signal-to-Noise Ratio : 94dB
- Input Audio Data Length : 16bits or 18bits
- Single ended Analog Output
- Internal SC type Low Pass Filter
- Operating Voltage +5V \pm 5%
- Package Outline DIP16 / DMP16

■ PIN CONFIGURATION

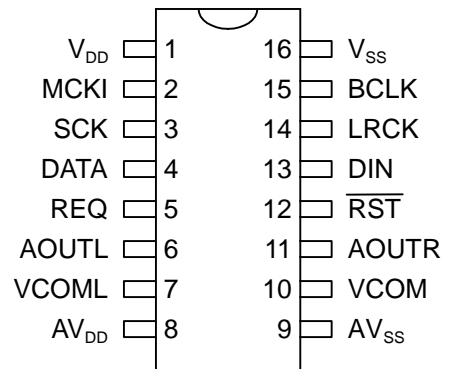

■ BLOCK DIAGRAM

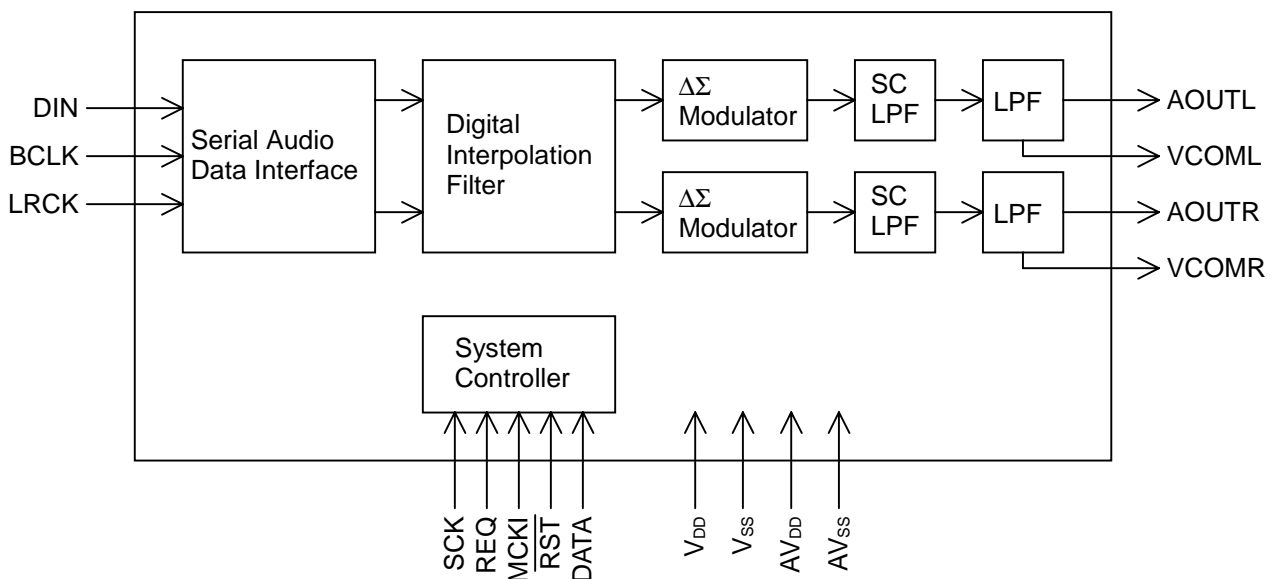

■ TERMINAL DESCRIPTION

PIN No.	SYMBOL	INPUT /OUTPUT	FUNCTION
1	V _{DD}	—	Digital Power Supply, +5V
16	V _{SS}	—	Digital GND, 0V
8	AV _{DD}	—	Analog Power Supply, +5V
9	AV _{SS}	—	Analog GND, 0V
2	MCKI	I	Master Clock Input Terminal The input signal frequency is 256 times or 384 times of fs.
13	DIN	I	Serial Audio Data Input Terminal
14	LRCK	I	L/R Channel Clock Input Terminal This clock must synchronize with MCKI.
15	BCLK	I	Audio Serial Data Clock Input Terminal This clock must synchronize with MCKI.
3	SCK	I	Control Register Serial Data Sift Clock Input Terminal Control register leads the control data synchronizing the rising edge of SCK signal. When the control register is not used, the state of SCK terminal has to keep level "H".
4	DATA	I	Control Register Serial Data Input Terminal Input data sets various functions. When the control register is not used, the state of DATA terminal has to keep level "H".
5	REQ	I	Control Register Serial Data Request Input Terminal The control data are latched in the control register at the rising edge of REQ signal. When the control register is not used, the state of REQ terminal has to keep level "H".
12	$\overline{\text{RST}}$	I	Reset "L" level signal into reset terminal initializes the system.
7	VCOML	—	Left channel Analog Signal Common Terminal for Connecting Smooth Capacitor A chemical capacitor should be connected between this terminal and AV _{SS} for stabilizing.
10	VCOMR	—	Right Channel Analog Signal Common Terminal for Connecting Smooth Capacitor A chemical capacitor should be connected between this terminal and AV _{SS} for stabilizing.
6	AOUTL	O	L-Channel Analog Signal Output Terminal
11	AOUTR	O	R-Channel Analog Signal Output Terminal

FUNCTION DESCRIPTION

(1-1) Analog Audio Signal Output

Analog signal output is biased in the chip and the maximum amplitude is $0.56 \times AV_{DD}$. The internal switched capacitor Low Pass Filter is so effective that the external Low Pass Filters are required only 2-pole LPF or 3-pole.

(1-2) Serial Data Interface

DIN (Data Input), BCLK (Bit Clock) and LRCK (L/R Clock) are the serial data interface terminals. BCLK is the bit clock of audio data and IO data are leaded at raising edge of the BCLK. The signal into LRCK terminal represents the signal for distinguishing between Lch and Rch, and the signal for starting data. The frequency of LRCK is sampling rate of system (f_s). The MCIK must be synchronized with LRCK and is 256 times or 384 of f_s . The serial data format is complement of 2, MSB-first and compatible with I²S serial data protocol or LSB justified. This serial data format is set by the control register.

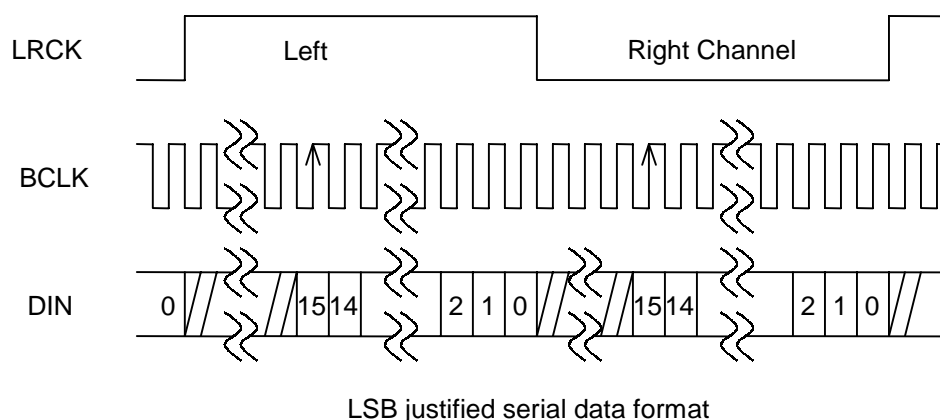
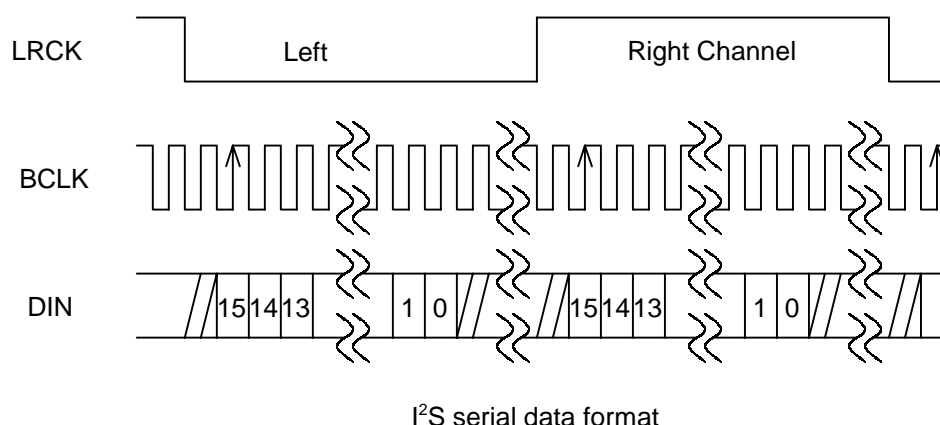

(1-3) System Clock

System Clock into the MCIK terminal must be 256 times or 384 times of f_s and synchronizing with LRCK. This frequency is set by the control register.

(1-4) Reset

The external reset is the asynchronous reset. Reset is released at the falling edge at LRCK. Reset by command is synchronous which operates as same as the external reset function.

(1-5) Control Register

The Control Register controls **NJU8402** operation using the serial interface. The SCK terminal is the data shift clock, the REQ terminal is data request signal, the DATA terminal is the serial data input. The control data is loaded into the shift register at rising edge of SCK, then it is latched at the rising edge of REQ. The least 8-bit data, which order is MSB first, is valid for control.

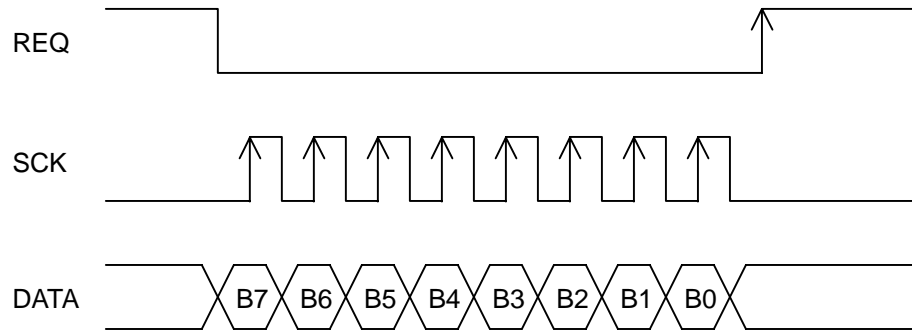

CONTROL PORT TIMING CHART

• Serial Data Format

B7	B6	B5	B4	B3	B2	B1	B0
0	0	0	0	*	DIF1	DIF0	CLKR
0	0	0	1	*	*	*	RST

(*: Don't Care)

*1 Don't input commands except this table.

		0	1	Default
System Clock	CLKR	256fs	384fs	0
Data Length	DIF0	16	18	0
Format	DIF1	I ² S	LSB Justified	0
Reset	RST	Normal	Reset	*2

*2 The level becomes 0 after initial setting.

■ ABSOLUTE MAXIMUM RATING

($V_{SS}=AV_{SS}=0V$)

PARAMETER		SYMBOL	CONDITIONS	UNIT
Power Supply	DIGITAL	V_{DD}	-0.3 to +7.0	V
	ANALOG	AV_{DD}	-0.3 to +7.0	V
	$V_{DD} - AV_{DD}$	ΔV_{AVD}	$ V_{DD} - AV_{DD} < 0.2$	V
Input Voltage		V_{IN}	-0.3 to $V_{DD} + 0.3$	V
Operating Temperature		T_a	-30 to +80	°C
Storage Temperature		T_{stg}	-40 to +125	°C
Power Consumption		PD	500(DIP16) 200(DMP16)	mW

■ RECOMMENDATION OPERATION CONDITION

($V_{SS}=AV_{SS}=0V$)

PARAMETER		SYMBOL	CONDITIONS			UNIT
			MIN.	TYP.	MAX.	
Power Supply	DIGITAL	V_{DD}	4.75	5.0	5.25	V
	ANALOG	AV_{DD}	4.75	5.0	5.25	V

■ ELECTRICAL CHARACTERISTICS

• ANALOG AC CHARACTERISTICS

(The case without the report $T_a=25^\circ\text{C}$, $V_{DD}=AV_{DD}=5.0\text{V}$, $f_s=44.1\text{kHz}$, Input Signal Frequency=1kHz, Input Signal Level=Full Scale, MCKI=256fs, Bandwidth=22Hz to 20kHz)

PARAMETER	SYMBOL	CONDITIONS	MIN.	TYP.	MAX.	UNIT	NOTE
Resolution			—	16	—	bit	
S/N	S/N	EIAJ, A-weight	90	94	—	dB	
Dynamic Range	DR	EIAJ, A-weight	—	94	—	dB	
THD+N	THD+N	Output 0dB	—	-88	-82	dB	
Channel Separation		EIAJ(1kHz)	—	90	—	dB	
Differential Gain Between Channels			—	0.1	0.3	dB	
Gain Drift			—	100		ppm/°C	
Maximum Output Voltage			$0.55 \times AV_{DD}$	$0.57 \times AV_{DD}$	$0.59 \times AV_{DD}$	V_{PP}	
Bias			—	$0.50 \times AV_{DD}$	—	V	
Output Load Resistance			10	—	—	k Ω	
Output Load Capacitance			—	—	300	pF	

BLOCK DIAGRAM FOR TESTING ANALOG AC CHARACTERISTICS

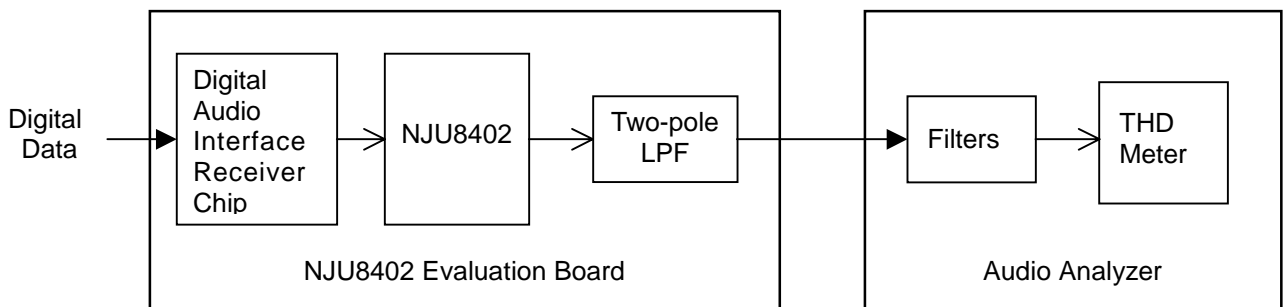

Two-pole LPF : $f_c=25\text{kHz}$ (refer ■ APPLICATION CIRCUITS)
 Filters : 22Hz HPF + 20kHz Ten-pole LPF
 (A-Weighting Filter is on at measuring S/N and Dynamic Range)

• **DIGITAL INTERPOLATION FILTER CHARACTERISTICS**

(The case without the report. $T_a=25^{\circ}\text{C}$, $V_{DD}=AV_{DD}=5.0\text{V}$, $f_s=44.1\text{kHz}$)

PARAMETER	SYMBOL	CONDITIONS	MIN.	TYP.	MAX.	UNIT	NOTE
Band Pass	PB		0.02	—	20.0	kHz	
Rejection Band	SB		24.10	—	—	kHz	
Rejection Band Quantity	SA		50	—	—	dB	

Note :Band Pass and Rejection Band are proportioned to f_s . $PB=0.4535 \times f_s$, $SB=0.5465 \times f_s$

• **DIGITAL ANALOG LOW PASS FILTER CHARACTERISTIC**

(The case without the report. $T_a=25^{\circ}\text{C}$, $V_{DD}=AV_{DD}=5.0\text{V}$, $f_s=44.1\text{kHz}$)

PARAMETER	SYMBOL	CONDITIONS	MIN.	TYP.	MAX.	UNIT	NOTE
Frequency Response	FR	22Hz~20kHz	—	± 0.2	—	dB	

• **POWER CHARACTERISTICS**

(The case without the report $T_a=25^{\circ}\text{C}$, $V_{DD}=AV_{DD}=5.0\text{V}$, $f_s=44.1\text{kHz}$)

PARAMETER	SYMBOL	CONDITIONS	MIN.	TYP.	MAX.	UNIT	NOTE
Supply Voltage	V_{DD} , AV_{DD}		4.75	5.0	5.25	V	
Supply Current	V_{DD}	I_{DD} No signal	—	12	14	mA	
	AV_{DD}	AI_{DD} No signal	—	10	18	mA	

• **DIGITAL DC CHARACTERISTICS**

(The case without the report $T_a=25^{\circ}\text{C}$, $V_{DD}=AV_{DD}=5.0\text{V}$)

PARAMETER	SYMBOL	CONDITIONS	MIN.	TYP.	MAX.	UNIT	NOTE
Digital Input Voltage	V_{IH}		$0.7 V_{DD}$	—	V_{DD}	V	
	V_{IL}			—	$0.3 V_{DD}$	V	
Input Leakage Current	I_{LK}		—	—	± 1	μA	

• DIGITAL AC CHARACTERISTICS

(The case without the report $T_a=25^\circ\text{C}$, $V_{DD}=AV_{DD}=5.0\text{V}$)

Master Clock & Reset

PARAMETER		SYMBOL	CONDITIONS	MIN.	TYP.	MAX.	UNIT	NOTE
MCKI	Frequency	f_{MCKI}	256fs	1.024	—	12.8	MHz	
			386fs	9.216	—	19.2	MHz	
	Pulse Width High-Level	t_{MCKH}		20	—	—	ns	
	Pulse Width Low-Level	t_{MCKL}		20	—	—	ns	
Reset Low Level Width		t_{RST}		1	—	—	ns	

Digital Audio Signal Interface

PARAMETER		SYMBOL	CONDITIONS	MIN.	TYP.	MAX.	UNIT	NOTE
Audio DAC Sampling Rate		f_s		24	—	50	kHz	
Audio Data Setup Time		t_{DS}		50	—	—	ns	
Audio Data Hold Time		t_{DH}		50	—	—	ns	
BCLK Period		t_{BCLK}		1/(128fs)	—	—	ns	
BCLK Pulse Time "H"		t_{BCKH}		20	—	—	ns	
BCLK Pulse Time "L"		t_{BCKL}		20	—	—	ns	
BCLK Rise to LRCK Edge		t_{BLR}		40	—	—	ns	
LRCK Edge to BCLK Rise		t_{LRB}		40	—	—	ns	

Control Register Interface

PARAMETER		SYMBOL	CONDITIONS	MIN.	TYP.	MAX.	UNIT	NOTE
SCK Period		t_{SCK}		2	—	—	ns	
SCK Pulse Time "H"		t_{SCH}		0.8	—	—	ns	
SCK Pulse Time "L"		t_{SCL}		0.8	—	—	ns	
Control Data Setup Time		t_{DAS}		0.8	—	—	ns	
Control Data Hold Time		t_{DAH}		0.8	—	—	ns	
REQ Pulse Time "H"		t_{REH}		1.6	—	—	ns	
SCK Data Setup Time		t_{RQS}		0.8	—	—	ns	
REQ Hold Time		t_{RQH}		0.8	—	—	ns	

Input Signal Rise and Fall Time

PARAMETER		SYMBOL	CONDITIONS	MIN.	TYP.	MAX.	UNIT	NOTE
Input Signal Rise Time		t_{UP}		—	—	100	ns	
Input Signal Fall Time		t_{DN}		—	—	100	ns	

• TIMING CHART

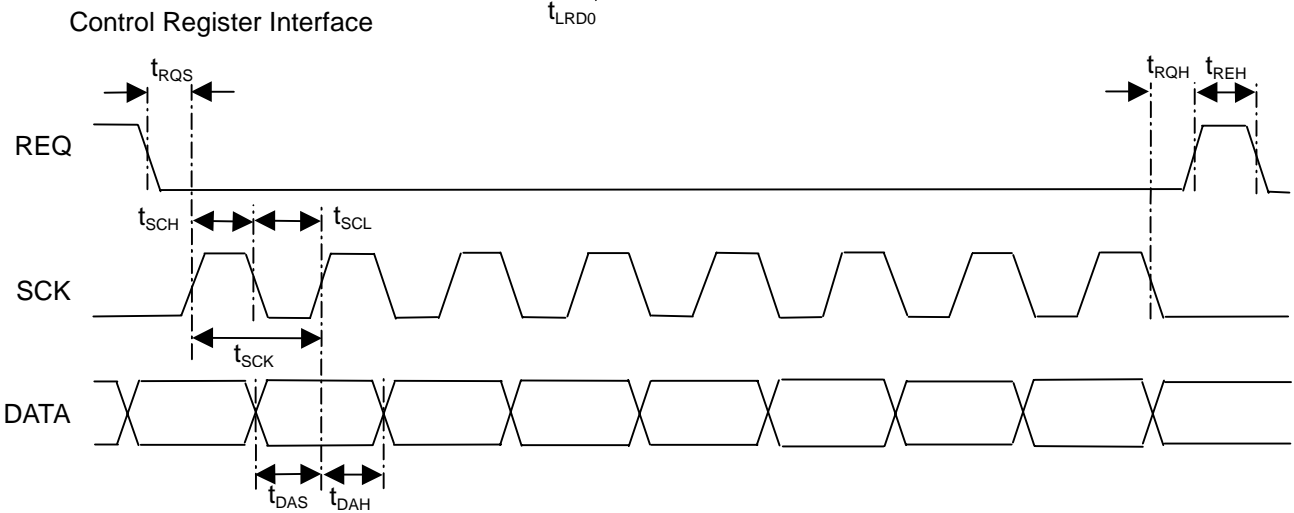
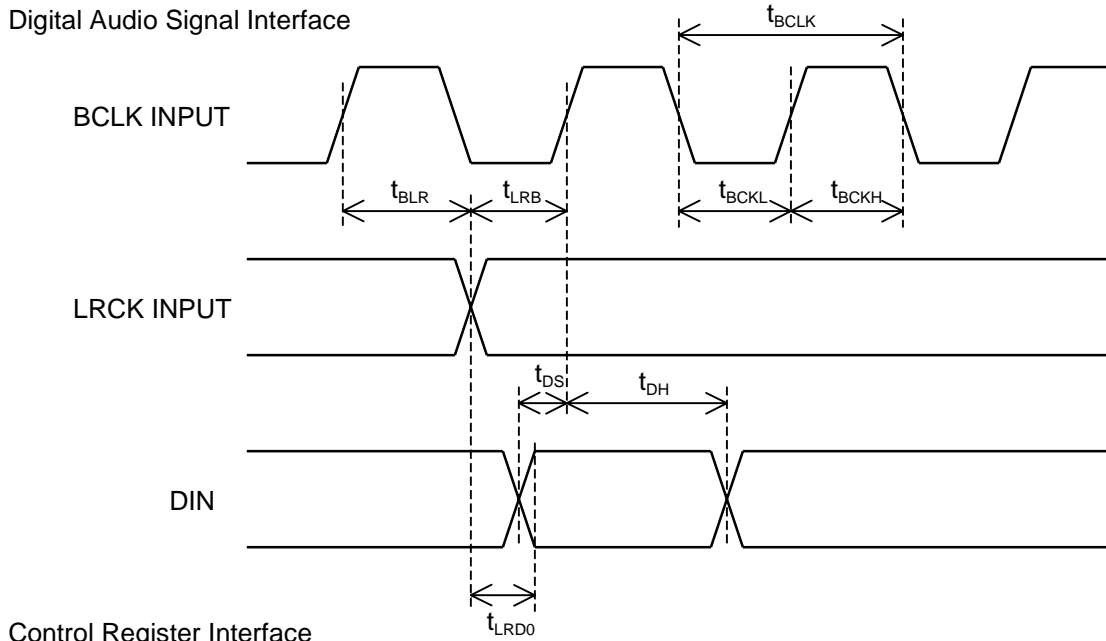
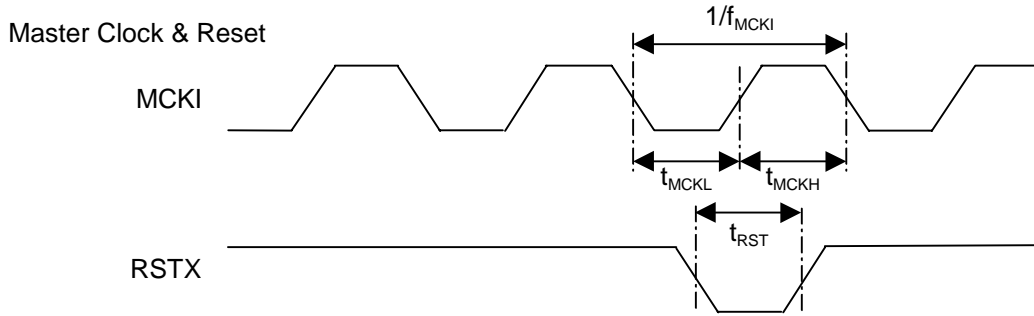

Input Signal Rise and Fall Time

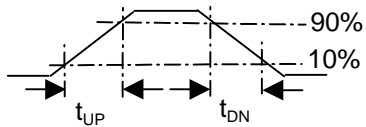

NJU8402

APPLICATION CIRCUITS

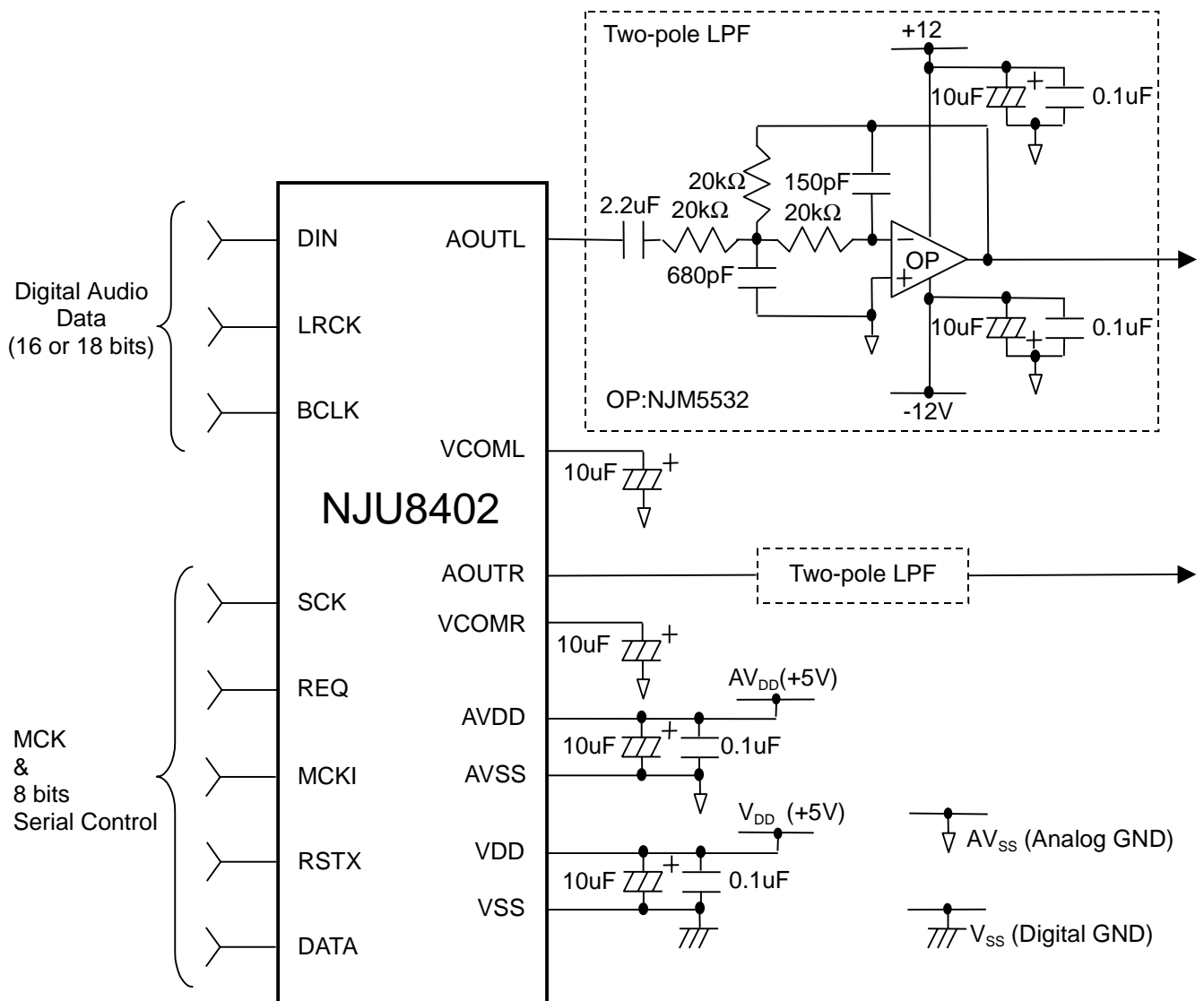

[CAUTION]
 The specifications on this databook are only given for information, without any guarantee as regards either mistakes or omissions. The application circuits in this databook are described only to show representative usages of the product and not intended for the guarantee or permission of any right including the industrial rights.