

MCA2230X, MCA2231X, MCA2255X
MCA2230, MCA2231, MCA2255



**OPTICALLY COUPLED ISOLATOR
PHOTODARLINGTON OUTPUT**

APPROVALS

- UL recognised, File No. E91231
- **'X' SPECIFICATION APPROVALS**
- **MCA2231X** -
VDE 0884 in 2 available lead form : -
- STD
- G form
VDE 0884 in SMD approval pending
- **MCA2230X, MCA2255X** -
VDE 0884 approval pending
- EN 60950 approval pending

DESCRIPTION

The MCA2230, MCA2231, MCA2255 series of optically coupled isolators consist of an infrared light emitting diode and NPN silicon photodarlington in a space efficient dual in line plastic package.

FEATURES

- Options :-
10mm lead spread - add G after part no.
Surface mount - add SM after part no.
Tape&reel - add SMT&R after part no.
- High Current Transfer Ratio
- High Isolation Voltage (5.3kV_{RMS}, 7.5kV_{PK})
- All electrical parameters 100% tested
- Custom electrical selections available

APPLICATIONS

- Computer terminals
- Industrial systems controllers
- Measuring instruments
- Signal transmission between systems of different potentials and impedances

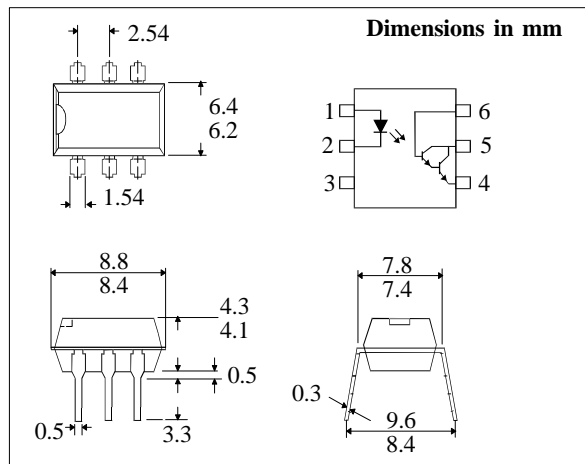
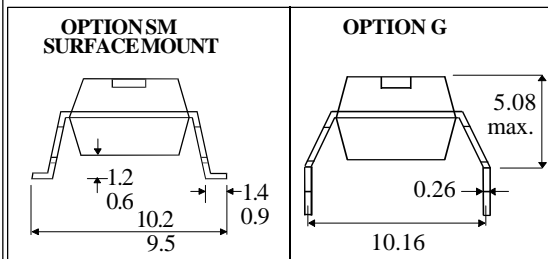

**ABSOLUTE MAXIMUM RATINGS
(25°C unless otherwise specified)**

Storage Temperature _____ -55°C to + 150°C
Operating Temperature _____ -55°C to + 100°C
Lead Soldering Temperature
(1/16 inch (1.6mm) from case for 10 secs) 260°C

INPUT DIODE

Forward Current _____ 80mA
Reverse Voltage _____ 6V
Power Dissipation _____ 105mW

OUTPUT TRANSISTOR

Collector-emitter Voltage BV_{CEO}
MCA2255 _____ 55V
MCA2230, MCA2231 _____ 30V
Collector-base Voltage BV_{CBO}
MCA2255 _____ 55V
MCA2230, MCA2231 _____ 30V
Emitter-base Voltage BV_{EBO} _____ 6V
Power Dissipation _____ 150mW

POWER DISSIPATION

Total Power Dissipation _____ 250mW
(derate linearly 3.3mW/°C above 25°C)

ISOCOM COMPONENTS LTD
Unit 25B, Park View Road West,
Park View Industrial Estate, Brenda Road
Hartlepool, Cleveland, TS25 1YD
Tel: (01429) 863609 Fax :(01429) 863581

ISOCOM INC
1024 S. Greenville Ave, Suite 240,
Allen, TX 75002 USA
Tel: (214) 495-0755 Fax: (214) 495-0901
e-mail info@isocom.com
http://www.isocom.com

ELECTRICAL CHARACTERISTICS ($T_A = 25^\circ\text{C}$ Unless otherwise noted)

PARAMETER		MIN	TYP	MAX	UNITS	TEST CONDITION	
Input	Forward Voltage (V_F)		1.2	1.5	V	$I_F = 20\text{mA}$ $I_R = 10\mu\text{A}$ $V_R = 3\text{V}$	
	Reverse Voltage (V_R)	3			V		
	Reverse Current (I_R)			10	μA		
Output	Collector-emitter Breakdown (BV_{CE0}) MCA2230, MCA2231	30			V	$I_C = 100\mu\text{A}$ (note 2)	
	MCA2255	55			V		
	Collector-base Breakdown (BV_{CBO}) MCA2230, MCA2231	30			V	$I_C = 10\mu\text{A}$ (note 2)	
	MCA2255	55			V		
	Emitter-base Breakdown (BV_{EBO})	5			V	$I_E = 10\mu\text{A}$	
	Collector-emitter Dark Current (I_{CE0})			100	nA	$V_{CE} = 10\text{V}$	
Coupled	Collector Output Current (I_C) (Note 2) MCA2230	100			%	$10\text{mA } I_F, 5\text{V } V_{CE}$ $10\text{mA } I_F, 5\text{V } V_{CE}$ $1\text{mA } I_F, 1\text{V } V_{CE}$	
	MCA2231, MCA2255	500			%		
		200			%		
	Collector-emitter Saturation Voltage $V_{CE(SAT)}$ MCA2230, MCA2255			1.0	V	$50\text{mA } I_F, 50\text{mA } I_C$ $1\text{mA } I_F, 2\text{mA } I_C$ $5\text{mA } I_F, 10\text{mA } I_C$ $10\text{mA } I_F, 50\text{mA } I_C$	
	MCA2231			1.0	V		
				1.0	V		
				1.2	V		
	Input to Output Isolation Voltage V_{ISO}	5300				V_{RMS}	(note 1)
		7500				V_{PK}	(note 1)
	Input-output Isolation Resistance R_{ISO}	5×10^{10}				Ω	$V_{IO} = 500\text{V}$ (note 1)
Output Turn on Time t_{on}		10			μs	$V_{CC} = 10\text{V}, R_L = 100\Omega,$ $I_F = 10\text{mA}$ (Fig.1)	
Output Turn off Time t_{off}		100			μs		

Note 1 Measured with input leads shorted together and output leads shorted together.

Note 2 Special Selections are available on request. Please consult the factory.

FIGURE 1

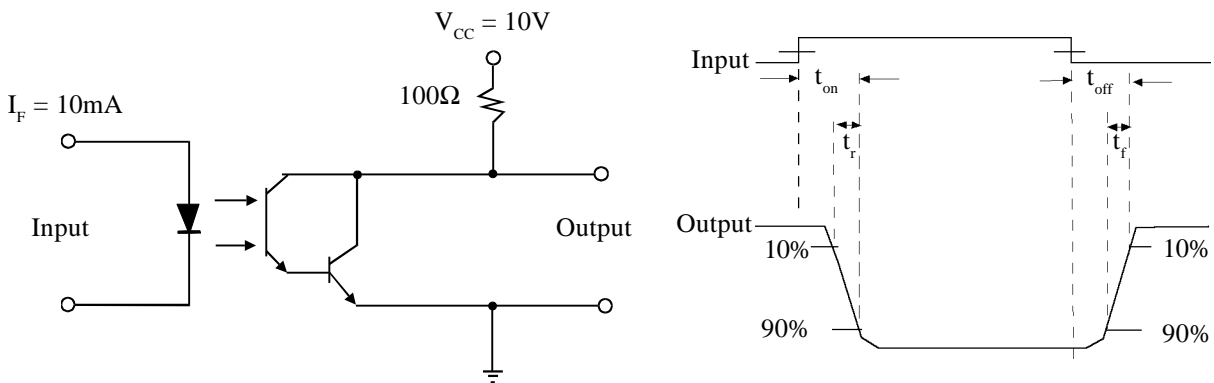

Collector Power Dissipation vs. Ambient Temperature



Current Transfer Ratio vs. Forward Current

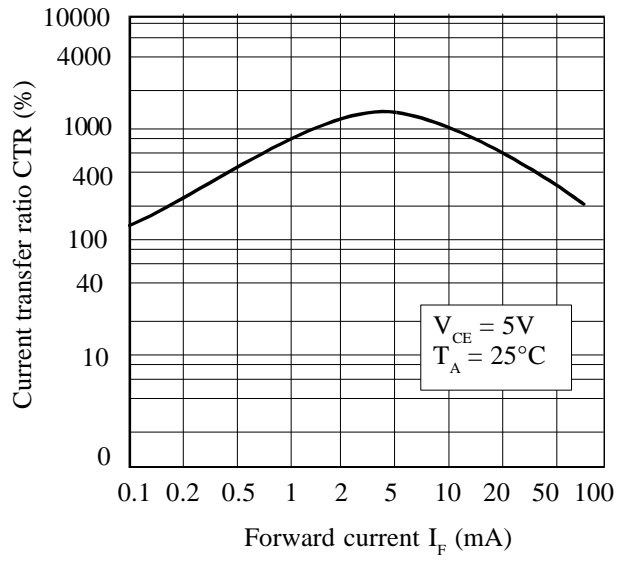

Forward Current vs. Ambient Temperature

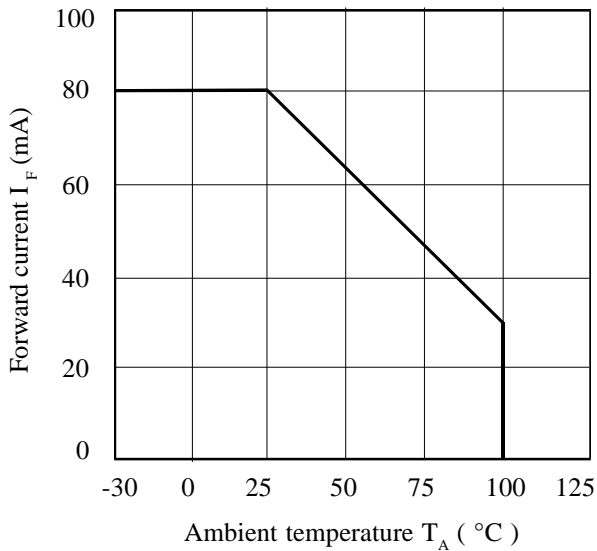

Collector Current vs. Collector-emitter Voltage

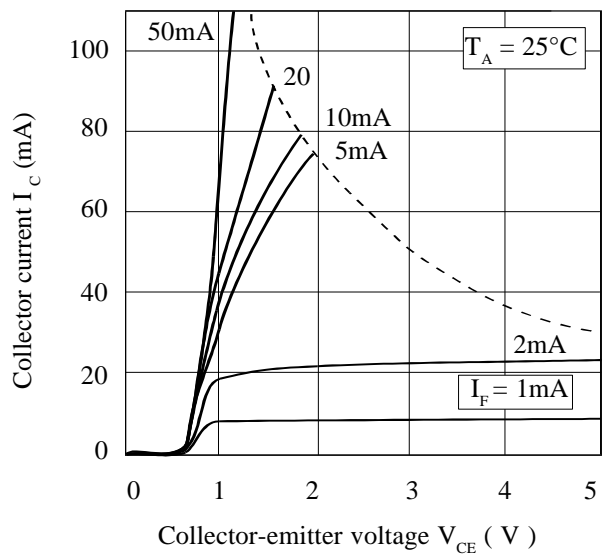

Collector-emitter Saturation Voltage vs. Ambient Temperature

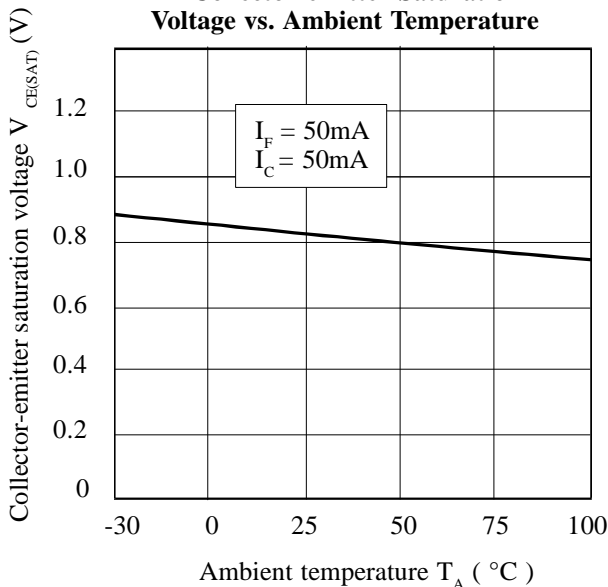

Relative Current Transfer Ratio vs. Ambient Temperature

