

6427525 N E C ELECTRONICS INC 05E 22859 D

BIPOLAR ANALOG INTEGRATED CIRCUIT

μ PC1287G

T-77-05-05

FM MULTIPLEX STEREO DEMODULATOR WITH NOISE CANCELLER

DESCRIPTION

The μ PC1287G is a silicon monolithic integrated circuit which includes FM stereo demodulator and noise canceller on the single chip, for use in automotive radio receivers.

FUNCTIONS

- Pilot canceller (with automatic control circuit)
- Stereo-noise control (SNC)
- High-cut control (HCC)
- Forced monaural (control pin No.24)

FEATURES

- Low distortion. THD = 0.1 % (TYP.), @ $V_i = 300 \text{ mV}_{r.m.s.}$
- High ripple rejection ratio. SVR = 33 dB (TYP.), @ $f_r = 200 \text{ Hz}$
- High maximum input level. $V_i \text{ (MAX.)} = 800 \text{ mV}_{r.m.s.}$ (TYP.), @ THD = 1.0 %
- A small number of external parts.

BLOCK DIAGRAM

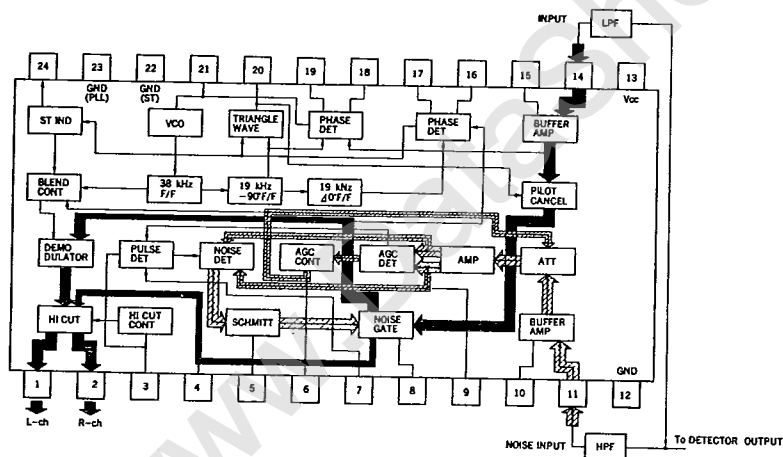

5

μ PC1287G

6427525 N E C ELECTRONICS INC

05E 22860 D

T-77-05-05

ABSOLUTE MAXIMUM RATINGS ($T_a = 25^\circ\text{C}$)

Supply Voltage	V_{CC}	16	V
Circuit Current	I_{CC}	67	mA
Package Dissipation	P_D	470*	mW
Operational Temperature	T_{opt}	-30 to +75	$^\circ\text{C}$
Storage Temperature	T_{stg}	-40 to +125	$^\circ\text{C}$

* $T_a = 75^\circ\text{C}$ RECOMMENDED OPERATING CONDITION ($T_a = 25^\circ\text{C}$)

CHARACTERISTIC	SYMBOL	MIN.	TYP.	MAX.	UNIT
Supply Voltage	V_{CC}	7.5	8.5	9.5	V

ELECTRICAL CHARACTERISTICS ($T_a = 25^\circ\text{C}$) $(V_{CC} = 8.5\text{ V}, V_{L+R} = 270\text{ mV}_{r.m.s.}, \text{Pilot} = 30\text{ mV}_{r.m.s.}, f = 1\text{ kHz})$

CHARACTERISTIC	SYMBOL	MIN.	TYP.	MAX.	UNIT	TEST CONDITIONS
Circuit Current	I_{CC}		39	60	mA	Quiescent
Supply Voltage Rejection Ratio	SVR		33		dB	$f_r = 200\text{ Hz}, V_r = 0.5\text{ V}_{r.m.s.}$ (without Line-filter)
Separation	Sep	35	40		dB	$f = 1\text{ kHz}$
Monaural Total Harmonic Distortion	THD1		0.1	0.5	%	$V_{in} = 300\text{ mV}_{r.m.s.}$ (Monaural)
Stereo Total Harmonic Distortion	THD2		0.1	0.7	%	L + R = 270 mV _{r.m.s.} Pilot = 30 mV _{r.m.s.}
Voltage Gain (Mono)	G_v	-4	-1	+2	dB	Monaural
Channel Balance	CB	-1.5	0	+1.5	dB	
Lamp-on Level	LAMP-ON	6.5	10	13.5	mV _{r.m.s.}	Pilot Only
Lamp Hysteresis	Hy	3	5	7	dB	
Capture Range	CR	± 2.3			%	
Ultrasonic Frequency Rejection	Rej(19)	15	17		dB	Triangular Wave Cancel
SCA Rejection	Rej(SCA)		67		dB	L + R = 240 mV _{r.m.s.} Pilot = 30 mV _{r.m.s.} SCA = 30 mV _{r.m.s.}
Signal to Noise Ratio	S/N	71	77		dB	$R_g = 4.7\text{ k}\Omega$
Maximum Input Level	$V_i(\text{MAX.})$	700	800		mV _{r.m.s.}	THD = 1 %
Control Current (Stereo \rightarrow Mono)	$I_{(\text{mono})}$		0.25	0.5	mA	L + R = 270 mV _{r.m.s.} Pilot = 30 mV _{r.m.s.}
Separation (Blend)	SepB		10		dB	Noise Level at $V_i\text{AGC} + 12\text{ dB}$
High-cut Operating Voltage	$V_{HC}(1)$	0.5	0.65	0.9	V	$C_{HC} = 10\ \mu\text{F}, -6\text{ dB point } (V_o)$
Voltage Gain (L.P.F.)	G_{VLPF}	0	0.8	1.6	dB	
Voltage Gain (H.P.F.)	G_{VHPP}	2	3.0	4	dB	
High-cut Control Noise	NHC		-60	-45	dBm	Din Noise Peak
Input Signal Voltage (AGC DET.)	V_{AGC}	-75	-71.5	-68	dBm	$f = 200\text{ kHz}$ AGC Terminal Voltage (V_G) = 0.55 V

6427525 N E C ELECTRONICS INC

μ PC1287G
05E 22861 D

T-77-05-05

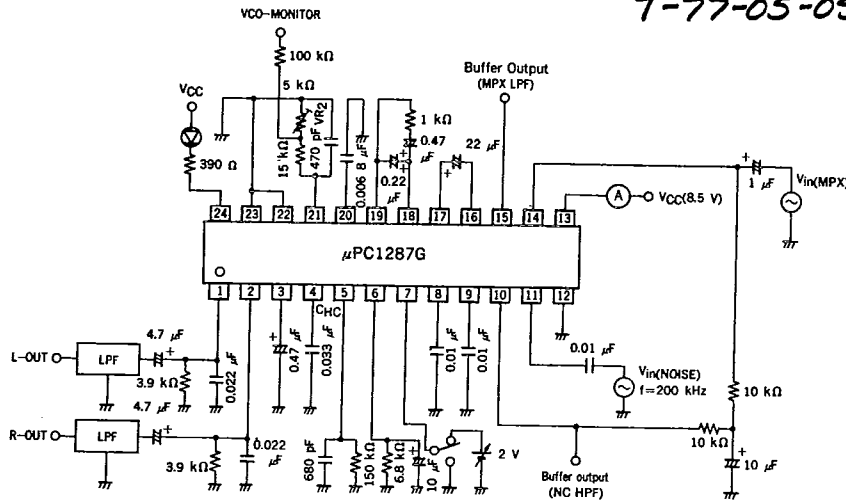

TEST CIRCUIT 2 (SEPARATION, THD (ST))

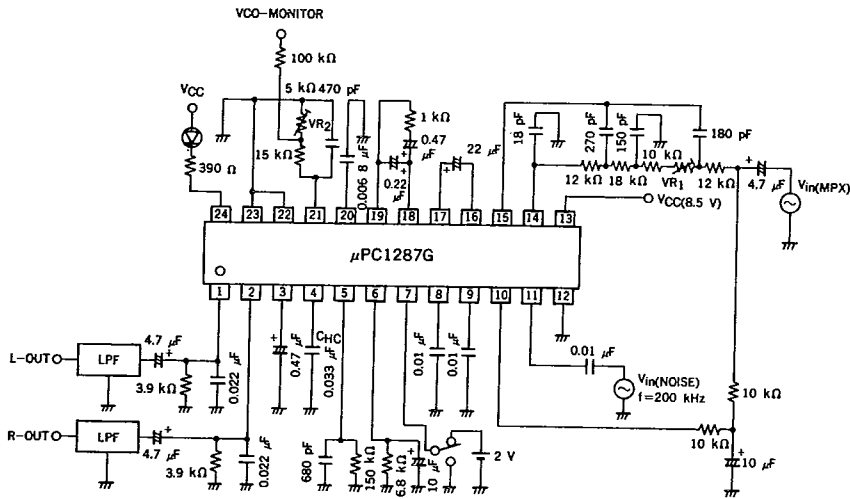

μ PC1287G

6427525 N E C ELECTRONICS INC

05E 22862 D

T-77-05-05

TYPICAL APPLICATION

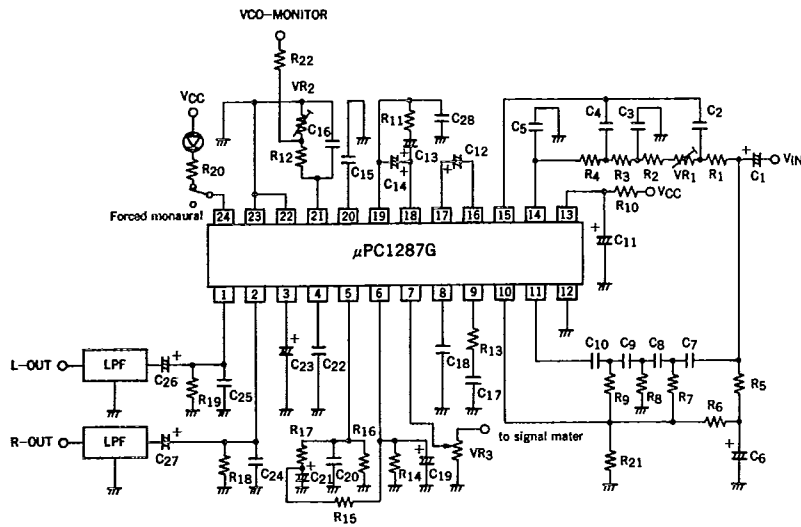

- VR₁ : SEPARATION ADJUSTMENT
 VR₂ : VCO ADJUSTMENT (76 kHz)
 VR₃ : HCC ADJUSTMENT (HCC off V₇ > 1.2 V)
 C₂₂ : HIGH-CUT FREQUENCY $f = 2.84 \times 10^{-5} / C_{22}$
 R₂₁ : BLEND SHIFT ADJUSTMENT (shift operating SNC)
 C₁₅ : LAMP ON LEVEL ADJUSTMENT

NOTE 1 : Value of VR₃ is recommended less than 33 k Ω .

- 2 : In case of sensing pulsive noise through the output for signal meter, don't use capacitor with large capacity at the output terminal for signal meter.
- 3 : Coefficient of VCO circuit (C₁₆, VR₂, R₁₂) is recommended -330 PPM/ $^{\circ}$ C
- 4 : C₂₁ and R₁₇ reduce AGC effect in the case that there is continual pulsive noise. Adjust AGC characteristic for successive pulsive noise by R₁₄ and R₁₅.
- 5 : C₁₉ is recommended solid tantalum capacitor.

6427525 N E C ELECTRONICS INC

μ PC1287G
05E 22863 D

TYPICAL CHARACTERISTICS ($T_a = 25^\circ\text{C}$)

T-77-05-05

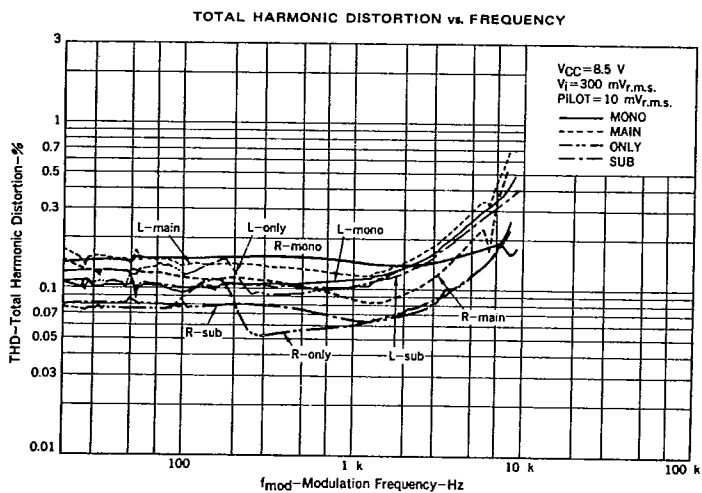
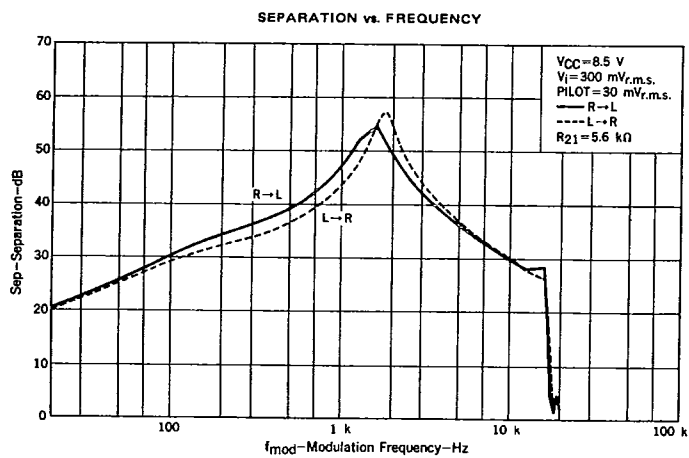

5

μ PC1287G
6427525 N E C ELECTRONICS INC

05E 22864 D

T-77-05-05

TERMINAL VOLTAGE (V_G), SEPARATION vs. NOISE INPUT VOLTAGE

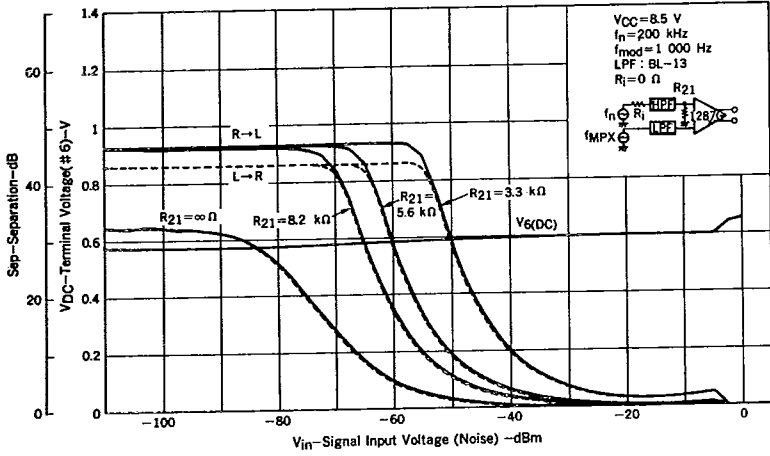

TERMINAL VOLTAGE (V_G), SEPARATION vs. NOISE INPUT VOLTAGE

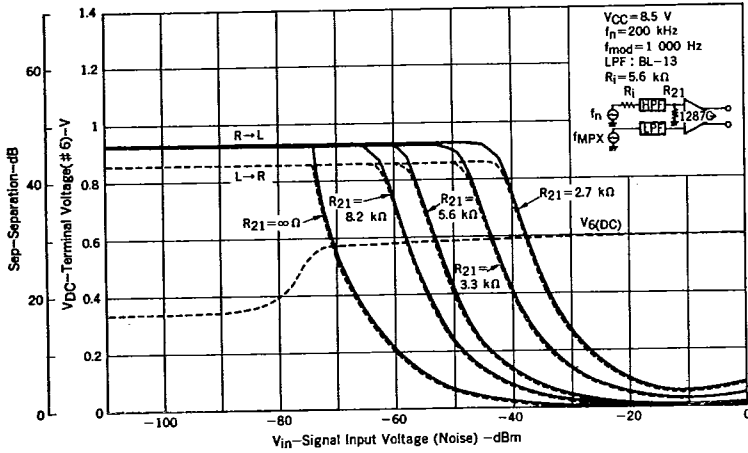

T-77-05-05

TERMINAL VOLTAGE (V_G), SEPARATION vs. NOISE INPUT VOLTAGE

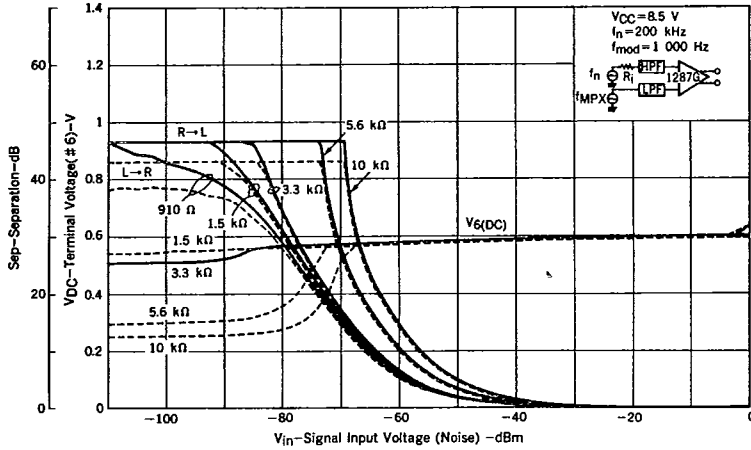

OUTPUT VOLTAGE vs. FREQUENCY

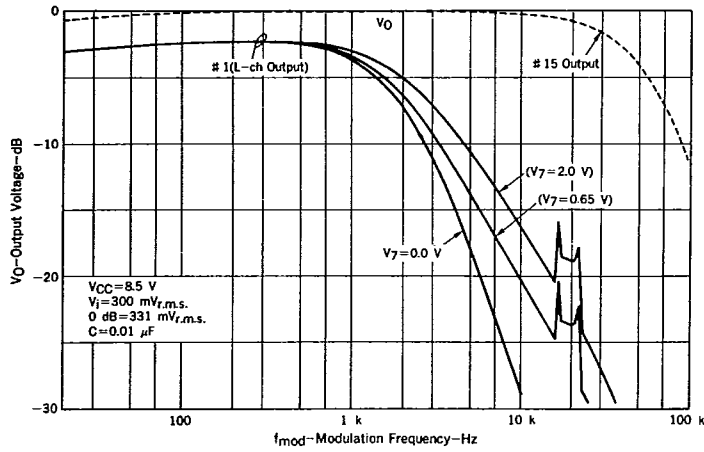

5

μPC1287G
 6427525 N E C ELECTRONICS INC

05E 22866 D

T-77-05-05

FREE RUNNING FREQUENCY vs. SUPPLY VOLTAGE

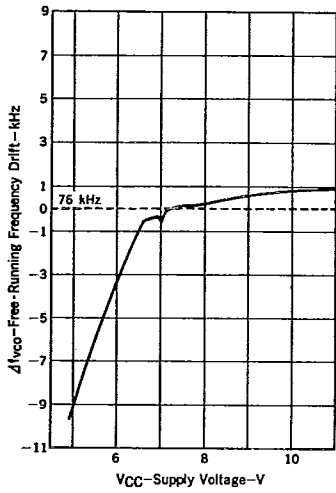

OUTPUT VOLTAGE, SEPARATION vs. TERMINAL VOLTAGE (V₇)

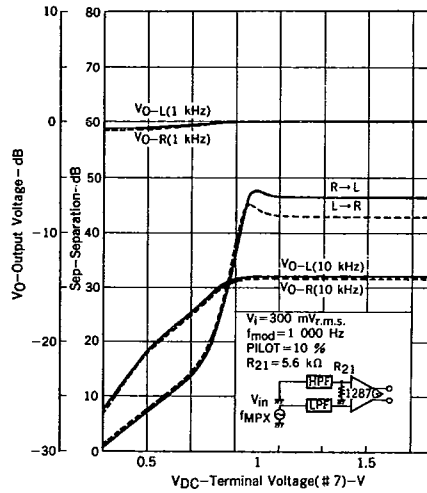

SEPARATION, OUTPUT VOLTAGE, TOTAL HARMONIC DISTORTION vs. INPUT VOLTAGE

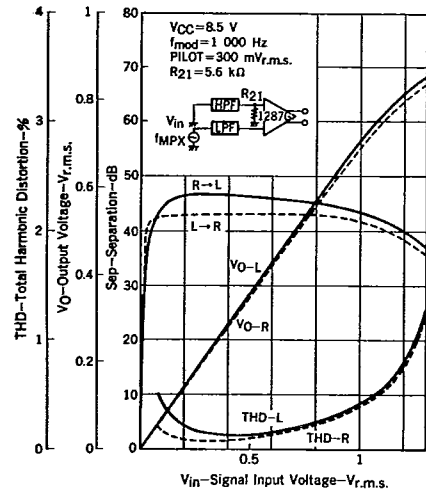

SEPARATION, CIRCUIT CURRENT, OUTPUT VOLTAGE vs. SUPPLY VOLTAGE

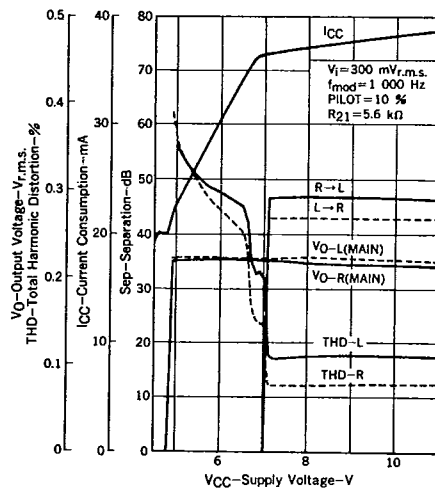

6427525 N E C ELECTRONICS INC

μ PC1287G

05E 22867 D
T-77-05-05

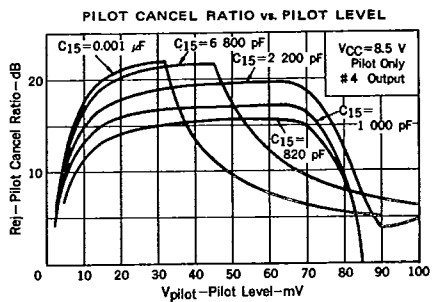

SEPARATION vs. FREE RUNNING FREQUENCY

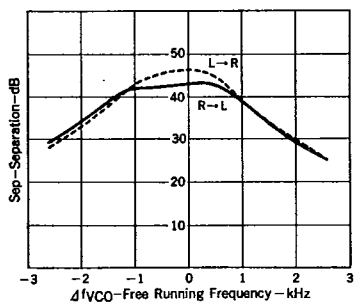

PILOT LEVEL vs. FREE RUNNING FREQUENCY

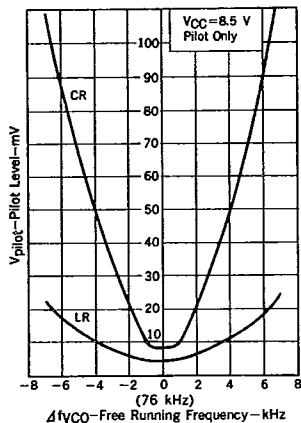

PULSE VOLTAGE vs. TERMINAL VOLTAGE

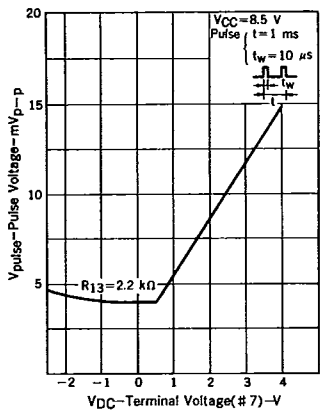

CAPACITANCE vs. PILOT LEVEL

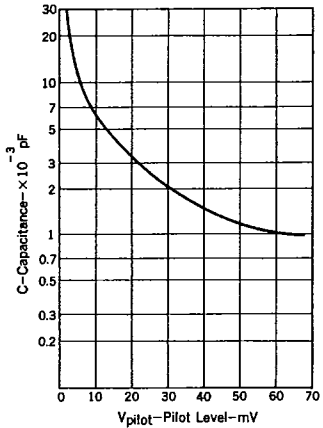

5

μPC1287G
6427525 N E C ELECTRONICS INC

05E 22868 D

OUTBOARD COMPONENTS MOUNTED ON A PRINTED-CIRCUIT BOARD

T-77-05-05

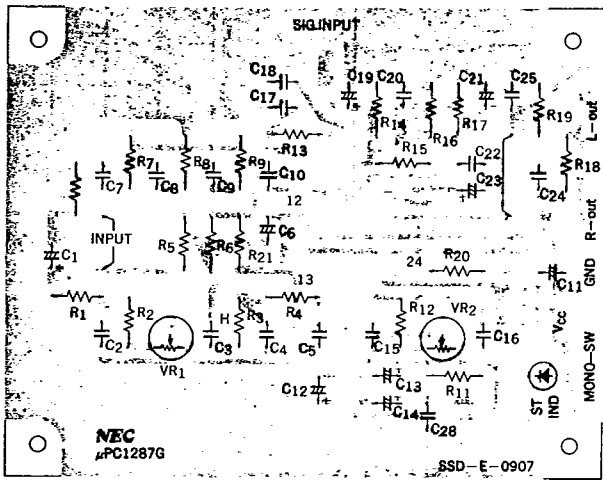

R1 = 12 kΩ	R11 = 1 kΩ	R21 = 5.6 kΩ	C1 = 2.2 μF	C11 = 100 μF	C21 = 1 μF
R2 = 10 kΩ	R12 = 15 kΩ	VR1 = 22 kΩ	C2 = 180 pF	C12 = 1 μF	C22 = 0.01 μF
R3 = 18 kΩ	R13 = 2.2 kΩ	VR2 = 5 kΩ	C3 = 150 pF	C13 = 0.47 μF	C23 = 0.47 μF
R4 = 12 kΩ	R14 = 22 kΩ		C4 = 270 pF	C14 = 0.22 μF	C24 = 0.022 μF
R5 = 10 kΩ	R15 = 12 kΩ		C5 = 18 pF	C15 = 0.0068 μF	C25 = 0.022 μF
R6 = 10 kΩ	R16 = 82 kΩ		C6 = 1 μF	C16 = 470 pF	C26 = 4.7 μF
R7 = 5.6 kΩ	R17 = 22 kΩ		C7 = 120 pF	C17 = 390 pF	C27 = 4.7 μF
R8 = 5.6 kΩ	R18 = 3.9 kΩ		C8 = 120 pF	C18 = 0.01 μF	C28 = 1500 pF
R9 = 5.6 kΩ	R19 = 3.9 kΩ		C9 = 150 pF	C19 = 10 μF	
R10 = 33 Ω	R20 = 470 Ω		C10 = 82 pF	C20 = 680 pF	

μ PC1287G

6427525 N E C ELECTRONICS INC

05E 22869 D

24PIN PLASTIC SOP (375 mil)

T-77-05-05

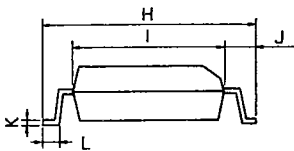
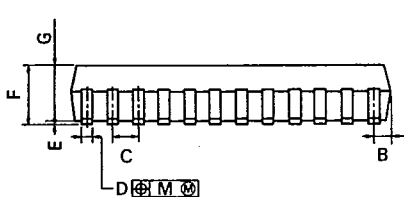
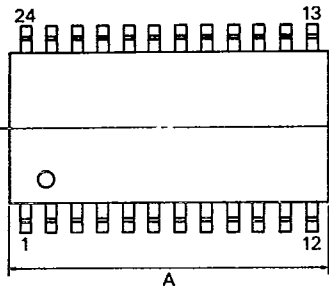

P24GM-50-375B

NOTE

Each lead centerline is located within 0.12 mm (0.005 inch) of its true position (T.P.) at maximum material condition.

ITEM	MILLIMETERS	INCHES
A	15.54 MAX.	0.612 MAX.
B	0.78 MAX.	0.031 MAX.
C	1.27 (T.P.)	0.050 (T.P.)
D	0.40 ^{+0.08}	0.016 ^{+0.003}
E	0.1 ^{+0.1}	0.004 ^{+0.004}
F	2.9 MAX.	0.115 MAX.
G	2.50	0.098
H	10.3 ^{+0.3}	0.406 ^{+0.013}
I	7.2	0.283
J	1.6	0.063
K	0.15 ^{+0.08}	0.006 ^{+0.003}
L	0.8 ^{+0.2}	0.031 ^{+0.008}
M	0.12	0.005

5