

SDC2UL6484-(67/84/100)T-S

16MByte (2M x 64) CMOS

Synchronous DRAM Module

General Description

The SDC2UL6484-(67/84/100)T-S is a high performance, 16-megabyte synchronous, dynamic RAM module organized as 2M words by 64 bits, in a 168-pin, dual-in-line memory module (DIMM) package.

The module utilizes eight Fujitsu MB81116822C-(67/84/100)FN CMOS 2Mx8 synchronous dynamic RAMs in surface mount package (TSOP) on an epoxy laminated substrate. Each device is accompanied by a decoupling capacitor for improved noise immunity.

A 256 Byte Serial EEPROM contains the module configuration information.

Features

- High Density: 16MByte
- Cycle Time: 10ns (100MHz), 12ns (84MHz), 15ns (67MHz)
- Low Power: Active 4.2W (100MHz), 3.9W (84MHz), 3.6W (67MHz)
- LVTTTL-compatible inputs and outputs
- Separate power and ground planes to improve noise immunity
- Single power supply of 3.3V±0.3V
- Height: 1.150 inch

ABSOLUTE MAXIMUM RATINGS

Item	Symbol	Ratings	Unit
Voltage on any pin relative to V _{SS}	V _T	-0.5 to +4.6	V
Power Dissipation	P _T	10.4	W
Operating Temperature	T _{opr}	0 to +70	°C
Storage Temperature	T _{stg}	-55 to +125	°C
Short Circuit Output Current	I _{OS}	±50	mA

RECOMMENDED DC OPERATING CONDITIONS

(T_A = 0 to +70 °C)

Symbol	Parameter	Min	Typ	Max	Unit
V _{CC}	Supply Voltage	3.0	3.3	3.6	V
V _{SS}	Ground	0	0	0	V
V _{IH}	Input High voltage	2.0	-	V _{CC} +0.5	V
V _{IL}	Input Low voltage	-0.5	-	0.8	V

Functional Diagram

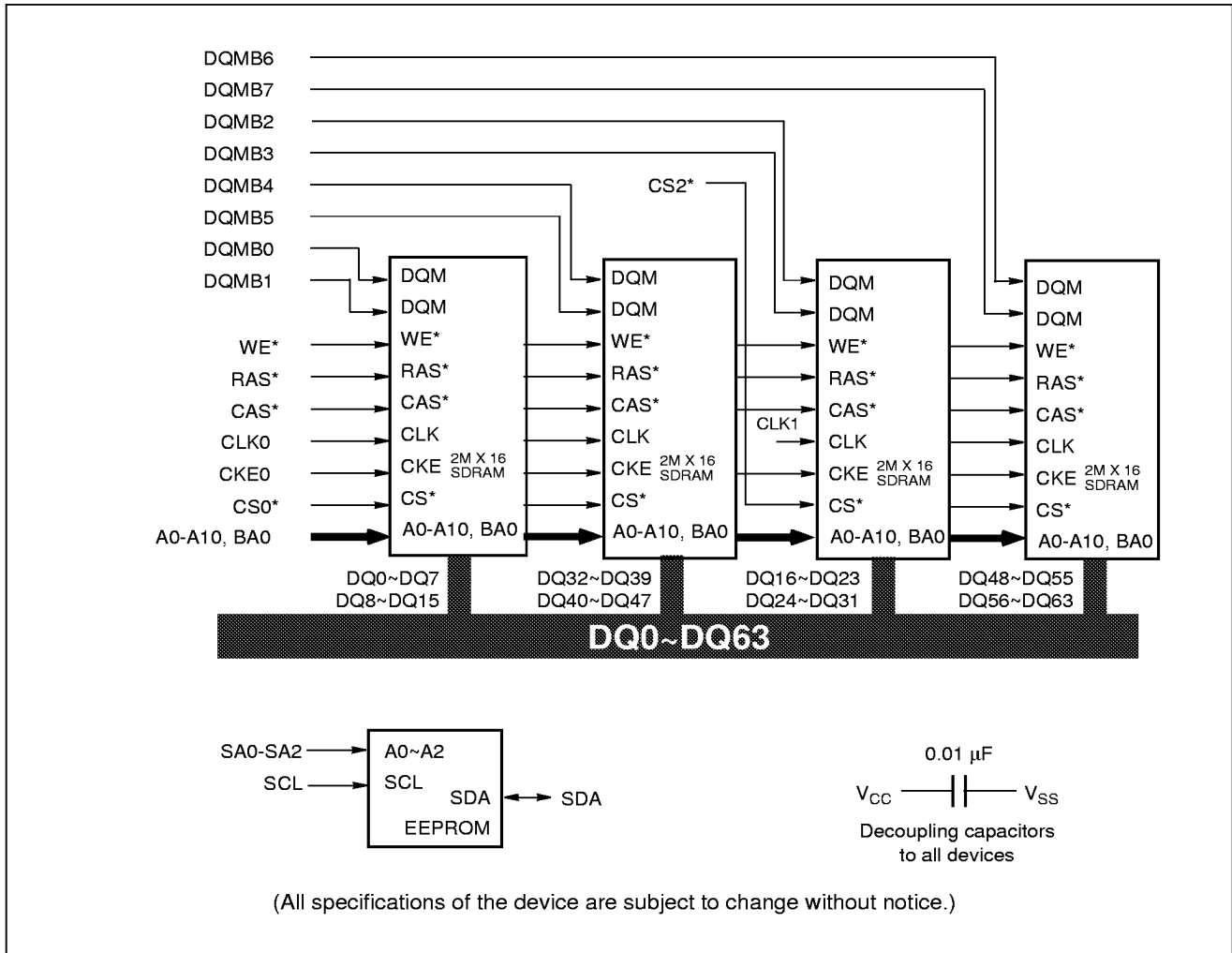

Notes: 1. Data and CLKs are terminated using 10 ohm series resistors.

2. Two 2Mx8 devices compose each 2Mx16 block.

3. DQMs vs Data I/Os

DQMB0 controls	DQ0 ~ DQ7
DQMB1 controls	DQ8 ~ DQ15
DQMB2 controls	DQ16 ~ DQ23
DQMB3 controls	DQ24 ~ DQ31
DQMB4 controls	DQ32 ~ DQ39
DQMB5 controls	DQ40 ~ DQ47
DQMB6 controls	DQ48 ~ DQ55
DQMB7 controls	DQ56 ~ DQ63

4. Clock Wiring

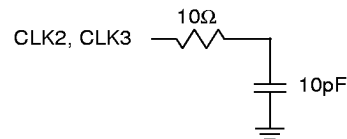
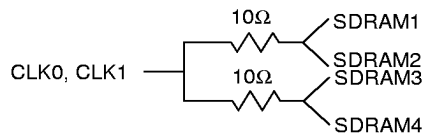

SDC2UL6484-(67/84/100)T-S

Pin Name

A0~A10	Addresses	CS0*, CS2*	Chip Select
BA0	Bank Select Address	WE*	Write Enable
DQ0~DQ63	Data Inputs/Outputs	SA0-SA2	Decode Input
CLK0~CLK3	Clock Inputs	SCL	Serial Clock
RAS*	Row Address Strokes	SDA	Serial Data Input/Output
CAS*	Column Address Strokes	V _{CC}	Power Supply
CKE0	Clock Enables	V _{SS}	Ground
DQMB0-DQMB7	DQ Mask Enables	NC	No Connection

Pin No.	Pin Designation	Pin No.	Pin Designation	Pin No.	Pin Designation	Pin No.	Pin Designation
1	V _{SS}	43	V _{SS}	85	V _{SS}	127	V _{SS}
2	DQ0	44	NC	86	DQ32	128	CKE0
3	DQ1	45	CS2*	87	DQ33	129	NC
4	DQ2	46	DQMB2	88	DQ34	130	DQMB6
5	DQ3	47	DQMB3	89	DQ35	131	DQMB7
6	V _{CC}	48	NC	90	V _{CC}	132	NC
7	DQ4	49	V _{CC}	91	DQ36	133	V _{CC}
8	DQ5	50	NC	92	DQ37	134	NC
9	DQ6	51	NC	93	DQ38	135	NC
10	DQ7	52	NC	94	DQ39	136	NC
11	DQ8	53	NC	95	DQ40	137	NC
12	V _{SS}	54	V _{SS}	96	V _{SS}	138	V _{SS}
13	DQ9	55	DQ16	97	DQ41	139	DQ48
14	DQ10	56	DQ17	98	DQ42	140	DQ49
15	DQ11	57	DQ18	99	DQ43	141	DQ50
16	DQ12	58	DQ19	100	DQ44	142	DQ51
17	DQ13	59	V _{CC}	101	DQ45	143	V _{CC}
18	V _{CC}	60	DQ20	102	V _{CC}	144	DQ52
19	DQ14	61	NC	103	DQ46	145	NC
20	DQ15	62	NC	104	DQ47	146	NC
21	NC	63	NC	105	NC	147	NC
22	NC	64	V _{SS}	106	NC	148	V _{SS}
23	V _{SS}	65	DQ21	107	V _{SS}	149	DQ53
24	NC	66	DQ22	108	NC	150	DQ54
25	NC	67	DQ23	109	NC	151	DQ55
26	V _{CC}	68	V _{SS}	110	V _{CC}	152	V _{SS}
27	WE*	69	DQ24	111	CAS*	153	DQ56
28	DQMB0	70	DQ25	112	DQMB4	154	DQ57
29	DQMB1	71	DQ26	113	DQMB5	155	DQ58
30	CS0*	72	DQ27	114	NC	156	DQ59
31	NC	73	V _{CC}	115	RAS*	157	V _{CC}
32	V _{SS}	74	DQ28	116	V _{SS}	158	DQ60
33	A0	75	DQ29	117	A1	159	DQ61
34	A2	76	DQ30	118	A3	160	DQ62
35	A4	77	DQ31	119	A5	161	DQ63
36	A6	78	V _{SS}	120	A7	162	V _{SS}
37	A8	79	CLK2	121	A9	163	CLK3
38	A10	80	NC	122	BA0	164	NC
39	NC	81	NC	123	NC	165	SA0
40	V _{CC}	82	SDA	124	V _{CC}	166	SA1
41	V _{CC}	83	SCL	125	CLK1	167	SA2
42	CLK0	84	V _{CC}	126	NC	168	V _{CC}

SERIAL PD INFORMATION

		Function Supported			Hex Value		
Byte#	Function Described	100 Mhz	84 Mhz	67 Mhz	100 Mhz	84 Mhz	67 Mhz
0	# Bytes Written into serial memory at module mfr	128 bytes			80h		
1	Total # bytes of SPD memory device	256 bytes			08h		
2	Fundamental memory type	SDRAM			04h		
3	# Row Address on this assembly	11			0Bh		
4	# Column Addresses on this assembly	9			09h		
5	# Module Banks on this assembly	1			01h		
6	Data Width of this assembly	64 bits			40h		
7	Data Width of this assembly (continued)				00h		
8	Voltage interface standard of this assembly	LVTTL			01h		
9	SDRAM cycle time at CL=3 (tCLK)	10ns	12ns	15ns	A0h	C0h	F0h
10	SDRAM Access from Clock at CL=3 (tAC)	8.5ns	8.5ns	9.0ns	85h	85h	90h
11	DIMM configuration type	Non-Parity			00h		
12	Refresh Rate/Type	S/R, Normal 15.6 ms			80h		
13	SDRAM Width Primary DRAM	x8			08h		
14	ECC SDRAM Data Width	N/A			00h		
15	Min. clock delay, Back to Back Random Column Addresses (ICCD)	1 CLK			01h		
16	Burst Length Supported	1, 2, 4, 8 & Full			8Fh		
17	# Banks on each SDRAM device	2			02h		
18	CAS# Latency	2, 3			06h		
19	CS# Latency	0			01h		
20	Write Latency	0			01h		
21	SDRAM Module Attribute	Non-Buffered/Registered			00h		
22	SDRAM Device Attribute	Vcc, B/R, S/W, P/A, A/P			0Eh		
23	Min Clock cycle Time at CL=2 (tCLK)	15ns	17ns	20ns	F0h	20h	50h
24	Max. Data Access Time from clock at CL=2 (tAC)	9.0ns	9.0ns	10ns	90h	90h	A0h
25	Min Clock cycle Time at CL=1 (tCLK)	N/A			FFh		
26	Max. Data Access Time from clock at CL=1 (tAC)	N/A			FFh		
27	Min. Row Precharge Time (tRP)	30ns	35ns	40ns	1Eh	23h	28h
28	Min. Row Active Delay (tRRD)	30ns	30ns	30ns	1Eh	1Eh	1Eh
29	Min. RAS to CAS Delay (tRCD)	30ns	30ns	30ns	1Eh	1Eh	1Eh
30	Min. RAS Pulse Width (tRAS)	60ns	65ns	70ns	3Ch	41h	46h
31	Module Bank Density	16MB			04h		
32-61	Superset Information				FFh		
62	SPD Revision	Rev. 1			01h		
63	Checksum for bytes 0-62	JEDEC Calculation			JEDEC Calculation		

SDC2UL6484-(67/84/100)T-S

SERIAL PD INFORMATION (CONTINUED)

Byte#	Function Described	Function Supported			Hex Value		
		100 Mhz	84 Mhz	67 Mhz	100 Mhz	84 Mhz	67 Mhz
64	Manufacturers JEDEC ID code per JEP-106E	Continuation code			7Fh		
65	Manufacturers JEDEC ID code per JEP-106E	SMART's ID			94h		
66-71	Manufacturers JEDEC ID code per JEP-106E	None			FFh		
72	Manufacturing location	Mfr Specific Data					
73	Manufacturer's Part Number	S			53h		
74	Manufacturer's Part Number	D			44h		
75	Manufacturer's Part Number	C			43h		
76	Manufacturer's Part Number	2			32h		
77	Manufacturer's Part Number	U			55h		
78	Manufacturer's Part Number	L			4Ch		
79	Manufacturer's Part Number	6			36h		
80	Manufacturer's Part Number	4			34h		
81	Manufacturer's Part Number	8			38h		
82	Manufacturer's Part Number	4			34h		
83	Manufacturer's Part Number	1	8	6	31h	38h	36h
84	Manufacturer's Part Number	0	4	7	30h	34h	37h
85	Manufacturer's Part Number	0	T	T	30h	54h	54h
86	Manufacturer's Part Number	T	S	S	54h	53h	53h
87	Manufacturer's Part Number	S	None	None	53h	FFh	FFh
88	Manufacturer's Part Number	None			FFh		
89	Manufacturer's Part Number	None			FFh		
90	Manufacturer's Part Number	None			FFh		
91	Revision Code	Mfr Specific Data			Mfr Specific Data		
92	Revision Code	None			FFh		
93	Manufacturing Date	DATE			DATE		
94	Manufacturing Date	DATE			DATE		
95-98	Assembly Serial Number	Serial Number			S.No.		
99	Manufacturer Specific Data	S			53h		
100	Manufacturer Specific Data	M			4Dh		
101	Manufacturer Specific Data	A			41h		
102	Manufacturer Specific Data	R			52h		
103	Manufacturer Specific Data	T			54h		
104	Manufacturer Specific Data	M			4Dh		
105	Manufacturer Specific Data	o			6Fh		
106	Manufacturer Specific Data	d			64h		
107	Manufacturer Specific Data	u			75h		
108	Manufacturer Specific Data	l			6Ch		
109	Manufacturer Specific Data	a			61h		
110	Manufacturer Specific Data	r			72h		
111	Manufacturer Specific Data	T			54h		
112	Manufacturer Specific Data	e			65h		
113	Manufacturer Specific Data	c			63h		
114	Manufacturer Specific Data	h			68h		
115	Manufacturer Specific Data	n			6Eh		
116	Manufacturer Specific Data	o			6Fh		
117	Manufacturer Specific Data	l			6Ch		
118	Manufacturer Specific Data	o			6Fh		
119	Manufacturer Specific Data	g			67h		
120	Manufacturer Specific Data	i			69h		
121	Manufacturer Specific Data	e			65h		
122	Manufacturer Specific Data	s			73h		
123	Manufacturer Specific Data	None			FFh		
124	Manufacturer Specific Data	None			FFh		
125	Manufacturer Specific Data	None			FFh		
126 (*)	INTEL specification frequency	66 Mhz			66h		
127 (*)	INTEL specification CAS# Latency Support	2,3			06h		
128-255	Open for CPQ Use for Read & Write	None			FFh		

(*) INTEL specification extension: These bytes are required for compatibility with previously released systems.

DC CHARACTERISTICS

 ($V_{CC} = 3.3V \pm 0.3V$, $V_{SS} = 0V$, $T_A = 0$ to $+70^\circ$)

Parameter	Symbol	Test Condition	100		84		67		Unit	Note
			Min.	Max.	Min.	Max.	Min.	Max.		
Operating Current	I_{CC1}	No Burst, $t_{CK} = \text{min.}$ $t_{RC} = \text{min.}$	-	680	-	640	-	600	mA	1, 2
		No Burst, $t_{CK} = \text{min.}$, $t_{RC} = \text{min.}$ All Banks Active	-	1120	-	1040	-	960	mA	1, 2
Precharge Standby Current	I_{CC2}	CKE - V_{IL} , $t_{CK} = \text{min.}$ All Banks Idle	-	1.2	-	1.2	-	1.2	mA	1, 2
		CKE = V_{IH} , $t_{CK} = \text{min.}$ All Banks Idle	-	160	-	160	-	160	mA	1.2
Active Standby Current	I_{CC3}	CKE = V_{IL} , $t_{CK} = \text{min.}$ Any Bank Active	-	200	-	200	-	200	mA	1, 2
		CKE = V_{IH} , $t_{CK} = \text{min.}$ Any Bank Active	-	360	-	360	-	360	mA	1, 2
Burst Mode Current	I_{CC4}	$t_{CK} = \text{min.}$	-	1160	-	1080	-	1000	mA	1, 2
Refresh Current	I_{CC5}	$t_{CK} = \text{min.}$, $t_{RC} = \text{min.}$, $t_{RRD} = \text{min.}$ Auto Refresh	-	600	-	560	-	520	mA	1, 2
Self Refresh Current	I_{CC6}	CKE - V_{IL}	-	2	-	2	-	2	mA	1, 2
Input Leakage	I_{LI}	$0V \leq V_{in} \leq V_{CC}$	-80	80	-80	80	-80	80	μA	
Output Leakage Current	I_{LO}	$0V \leq V_{out} \leq V_{CC}$ $D_{out} = \text{Disable}$	-10	10	-10	10	-10	10	μA	
Output High Voltage	V_{OH}	High $I_{out} = -2mA$	2.4	-	2.4	-	2.4	-	V	
Output Low Voltage	V_{OL}	Low $I_{out} = 2 mA$	-	0.4	-	0.4	-	0.4	V	

 $\dagger CL = CAS^*$ Latency

- Notes:
- I_{CC} depends on output load condition when the device is selected I_{CC} (max.) is specified at the output open condition.
 - An initial pulse of 200 μs is required after power-up followed by a minimum of eight Auto-Refresh-Cycles.

CAPACITANCE

 ($T_A = +25^\circ C$, $V_{CC} = 3.3V \pm 0.3V$)

Parameter	Symbol	Max.	Unit	Note
Input Capacitance (Address, WE*, CKE, RAS*, CAS*)	C_{I1}	37	pF	1
Input Capacitance (DQMBs)	C_{I2}	9	pF	1
Input Capacitance (CS0*, CS2*)	C_{I3}	21	pF	1
Input Capacitance (CLK0, CLK1)	C_{I4}	21	pF	1
Input Capacitance (CLK2, CLK3)	C_{I5}	15	pF	1
Input/Output Capacitance (DQ0~DQ63)	$C_{I/O}$	12	pF	1, 2

- Notes:
- Capacitance is measured with Boonton Meter or effective capacitance method.
 - $CAS^* - V_{IH}$ to disable D_{out} .

SDC2UL6484-(67/84/100)T-S

AC CHARACTERISTICS

(TA = 0 to +70°C, V_{CC} = 3.3V±0.3V, V_{SS} = 0V)

Parameter	Symbol	Unit	100		84		67		Notes	
Clock Period	CL=3	t _{CLK}	ns	10	-	12	-	15	-	1, 2, 3, 6
	CL=2			15	-	17	-	20	-	
Transition Time	t _T	ns	0.5	2	0.5	2	0.5	2	1, 2, 3	
Clock High Time	t _{CH}	ns	4	-	4	-	4	-	1, 2, 3	
Clock Low Time	t _{CL}	ns	4	-	4	-	4	-	1, 2, 3	
CS Setup Time	t _{SC}	ns	3.0	-	3.0	-	3.0	-	1, 2, 3	
CS Hold Time	t _{HC}	ns	1.0	-	1.0	-	1.0	-	1, 2, 3	
Input Setup Time	t _{SI}	ns	3.0	-	3.0	-	3.0	-	1, 2, 3	
Input Hold Time	t _{HI}	ns	1.0	-	1.0	-	1.0	-	1, 2, 3	
Output Valid from Clock	CL=3	t _{AC}	ns	-	8.5	-	8.5	-	9.0	1, 2, 3
	CL=2			-	9	-	9	-	10	
Output In Low-Z	t _{OLZ}	ns	3	-	3	-	3	-	1, 2, 3	
Output in High-Z	t _{OHZ}	ns	3	-	3	-	3	-	1, 2, 3, 4	
Output Hold Time	t _{OH}	ns	3	-	3	-	3	-	1, 2, 3	
Time between Refresh	t _{REF}	ms	-	65.6	-	65.6	-	65.6	1, 2, 3	
RAS Cycle Time	t _{RC}	ns	90	-	100	-	110	2	1, 2, 3, 5	
RAS Access Time	t _{RAC}	ns	-	54	-	56	-	60	1, 2, 3	
CAS Access Time	t _{CAC}	ns	-	24	-	26	-	30	1, 2, 3	
RAS Precharge Time	t _{RP}	ns	30	-	35	-	40	-	1, 2, 3	
RAS Active Time	t _{RAS}	ns	60	10000	65	-	70	10000	1, 2, 3	
RAS to CAS Delay Time	t _{RCD}	ns	30	-	30	-	30	-	1, 2, 3	
Write Recovery Time	t _{WR}	ns	10	-	12	-	15	-	1, 2, 3	
Write to Precharge Lead Time	t _{RWL}	ns	10	-	12	-	15	-	1, 2, 3	
RAS to RAS Delay Time	t _{RRD}	ns	30	-	30	-	30	-	1, 2, 3	
Power-down Exit Time	t _{PDE}	ns	3	-	4	-	5	-	1, 2, 3	
CKE to Clock Disable	t _{CKE}	cycle	1		1		1			
DQM to Output in High-Z	t _{DQZ}	cycle	2		2		2			
DQM to Input Data Delay	t _{DQD}	cycle	0		0		0			
Last Output to Write Command Delay	t _{OWD}	cycle	2		2		2			
Write Command to Input Data Delay	t _{DWD}	cycle	0		0		0			
Precharge to Output in High-Z Delay	CL=3	t _{ROH}	cycle	3		3		3		
	CL=2			2		2		2		
Mode Register Access to Bank Active (min.)	t _{MRD}	cycle	2		2		2			
CAS to CAS Delay	t _{CCD}	cycle	1		1		1			
CAS Bank Delay	t _{CBD}	cycle	1		1		1			

- Notes:
1. An initial pulse of at least 200μs is required after power-up followed by a minimum of eight auto refresh cycles.
 2. AC characteristics assume t_T = 1ns and 50pF capacitive load. If t_T is longer than 1ms, reference level for measuring time of input signal is V_{IH} (min.) and V_{IL} (max.).
 3. 1.4V is the reference level for measuring timing of input signals.
 4. t_{HZ} and t_{OH} defines the time at which the outputs achieve ±200mV.
 5. Actual clock output of t_{RC} will be sum clock of t_{RAS} and t_{RP}.
 6. 20ns is not supported in SPD.

Physical Dimensions

168-pin (84x2) DIMM

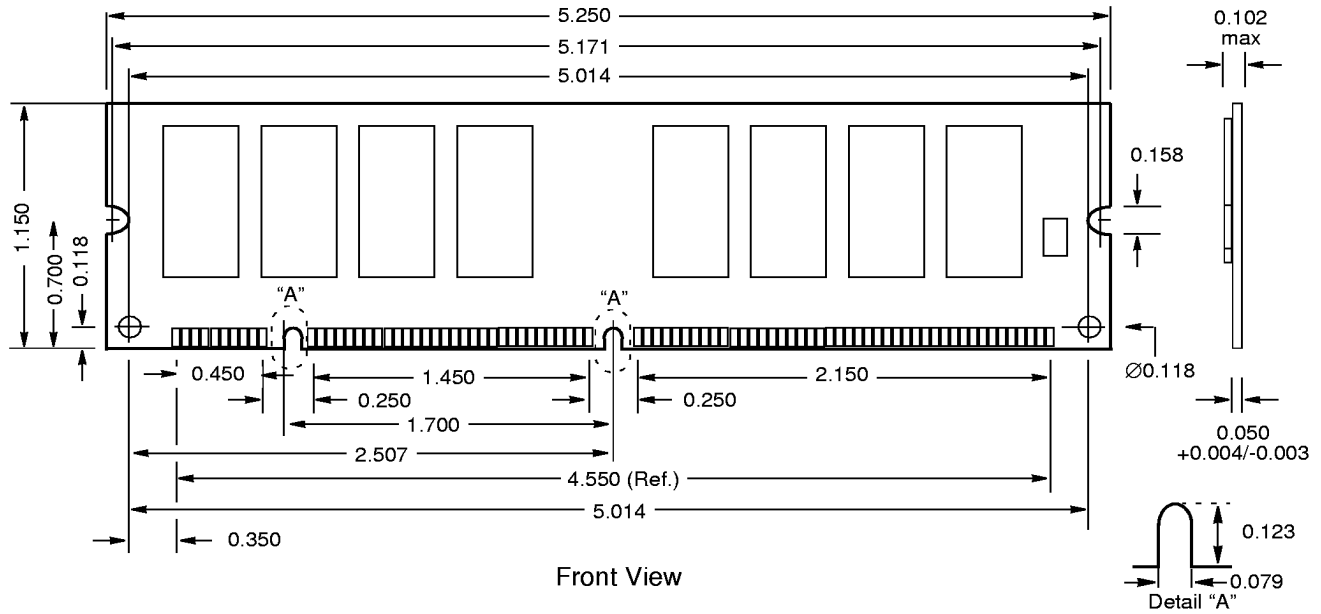

- Notes:
1. All dimensions are in inches.
 2. Pin 85 is behind pin 1 on the back side.

SDC2UL6484-(67/84/100)T-S

Ordering Information

S D C 2 U L 64 8 4 _ _ - 100 T - _ S
 (1) (2) (3) (4) (5) (6) (7) (8) (8a) (9) (10) (11) (12) (13) (14)

(1) **Memory Type**

S : SDRAM
G : SGRAM

(2) **Module Shape**

S : SIMM
D : DIMM
O : Small Outline DIMM

(3) **Module Pin Count**

A : 72-pin
B : 144-pin
C : 168-pin
D : 200-pin

(4) **Word Depth**

1 : 1M
2 : 2M
4 : 4M
8 : 8M
256 : 256K
512 : 512K

(5) **Buffer Type**

B : Buffered
U : Unbuffered

(6) **Operating Voltage & Power Consumption**

V : 3.3V & Standard Power
L : 3.3V & Low Power

(7) **Data Width**

(ex. 64=x64, 72=x72 etc.)

(8) **Device Configuration**

4 : x4
8 : x8
1 : x16
3 : x32

(8a) **Refresh**

2 : 2krf
4 : 4krf

(9) **Interface Level**

Blank : LVTTTL
S : SSTL

(10) **Module Revision / Applied "Standard" *1**

Blank : Rev. 0
A : Rev. 1
B : Rev. 2 (etc.)

*1 When DRAM device or PCB is revised, the revision is changed

(11) **Clock Frequency**

67 : 67Mhz
84 : 84Mhz
100 : 100Mhz
125 : 125Mhz

(12) **Package of Component**

J : SOJ
T : TSOP

(13) **Private Brand Name *2**

Blank : Common Products
G : FMG Brand

*2 This column is applicable to custom modules, NOT applicable to JEDEC standard commodity products

(14) **Assembly & Test Site**

S : Smart Modular Technologies