



NEC's HIGH CTR, 4 PIN SOP OPTOCOUPLER

PS2711-1

FEATURES

- **HIGH CURRENT TRANSFER RATIO:**
CTR = 200% TYP @ $I_F = 1 \text{ mA}$
- **HIGH ISOLATION VOLTAGE:**
 $BV = 3.75 \text{ k Vr.m.s.}$
- **SMALL THIN PACKAGE:**
4 pin SOP
- **AVAILABLE IN TAPE AND REEL**

DESCRIPTION

NEC's PS2711-1 is an optically coupled isolator containing a GaAs light emitting diode and an NPN silicon phototransistor in a plastic SOP (Small Out-Line Package) for high density applications.

APPLICATIONS

- PROGRAMMABLE LOGIC CONTROLLERS
- SMALL POWER SUPPLY
- HYBRID IC
- MODEM/FAX

ELECTRICAL CHARACTERISTICS (TA = 25°C)

PART NUMBER			PS2711-1			
SYMBOLS	PARAMETERS	UNITS	MIN	TYP	MAX	
Diode	V_F	Forward Voltage, $I_F = 5 \text{ mA}$	V	1.15	1.4	
	I_R	Reverse Current, $V_R = 5 \text{ V}$	μA		5	
	C_t	Terminal Capacitance, $V = 0 \text{ V}$, $f = 1.0 \text{ MHz}$	pF		30	
Transistor	I_{CEO}	Collector to Emitter Current, $I_F = 0 \text{ mA}$, $V_{CE} = 40 \text{ V}$	nA		100	
Coupled	CTR	Current Transfer Ratio (I_C/I_F) ¹ , $I_F = 1 \text{ mA}$, $V_{CE} = 5 \text{ V}$	%	100	200	400
	$V_{CE(sat)}$	Collector Saturation Voltage, $I_F = 1 \text{ mA}$, $I_C = 0.2 \text{ mA}$	V			0.3
	RI-O	Isolation Resistance, $V_{in-out} = 1.0 \text{ kVDC}$	Ω	10^{11}		
	CI-O	Isolation Capacitance, $V = 0$, $f = 1.0 \text{ MHz}$	pF		0.4	
	t_r	Rise Time ² , $V_{CC} = 5 \text{ V}$, $I_C = 2 \text{ mA}$, $R_L = 100 \Omega$	μs		4	
t_f	Fall Time ² , $V_{CC} = 5 \text{ V}$, $I_C = 2 \text{ mA}$, $R_L = 100 \Omega$	μs		5		

Notes:

1. CTR Rank

- N: 100 to 400 (%)
- K: 200 to 400 (%)
- L: 150 to 300 (%)
- M: 100 to 200 (%)

2. Test Circuit for Switching Time

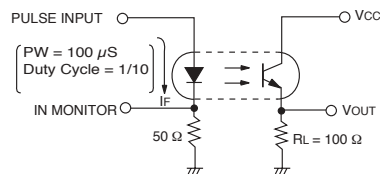

PS2711-1



ABSOLUTE MAXIMUM RATINGS¹ (T_A = 25°C)

SYMBOLS	PARAMETERS	UNITS	RATINGS
Diode			
V _R	Reverse Voltage	V	6
I _F	Forward Current (DC)	mA	50
ΔP _D /°C	Power Dissipation Derating	mW/°C	0.8
P _D	Power Dissipation	mW	80
I _{F(Peak)}	Peak Forward Current PW = 100 μs, Duty Cycle 1%	A	0.5
Transistor			
V _{CEO}	Collector to Emitter Voltage	V	40
V _{ECO}	Emitter to Collector Voltage	V	5
I _C	Collector Current	mA	40
ΔP _C /°C	Power Dissipation Derating	mW/°C	1.5
P _C	Power Dissipation	mW	150
Coupled			
BV	Isolation Voltage ²	V _{r.m.s.}	3750
T _A	Operating Ambient Temp.	°C	-55 to +100
T _{STG}	Storage Temperature	°C	-55 to +150

Notes:

- Operation in excess of any one of these parameters may result in permanent damage.
- AC voltage for 1 minute at T_A = 25 °C, RH = 60 % between input and output.

ORDERING INFORMATION

PART NUMBER	PACKAGE	PACKING STYLE
PS2711-1	4-pin SOP	50 pcs (Tape 50 pcs cut)
PS2711-1-F3		Embossed Tape 3500 pcs/reel
PS2711-1-F4		

OUTLINE DIMENSIONS (Units in mm)

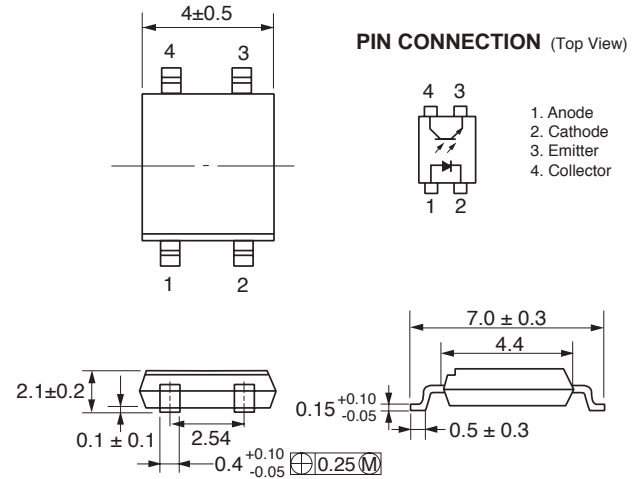

PACKAGE MARKING

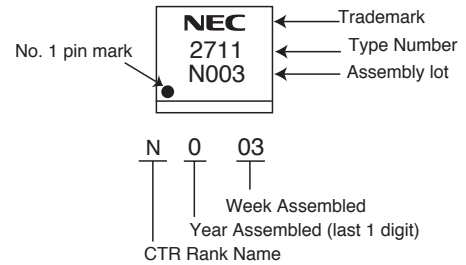

TYPICAL PERFORMANCE CURVES ($T_A = 25\text{ }^\circ\text{C}$)

DIODE POWER DISSIPATION vs. AMBIENT TEMPERATURE

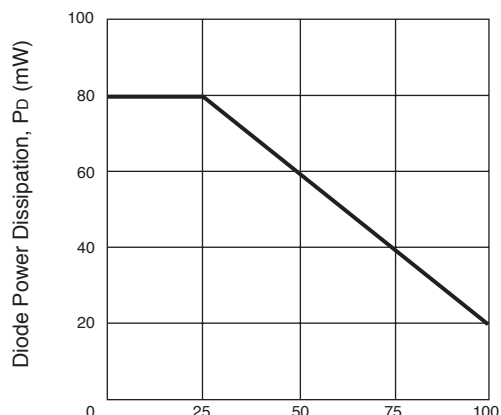

Ambient Temperature, T_A ($^\circ\text{C}$)

TRANSISTOR POWER DISSIPATION vs. AMBIENT TEMPERATURE

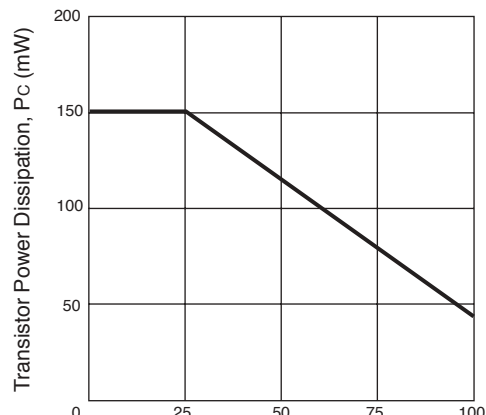

Ambient Temperature, T_A ($^\circ\text{C}$)

FORWARD CURRENT vs. FORWARD VOLTAGE

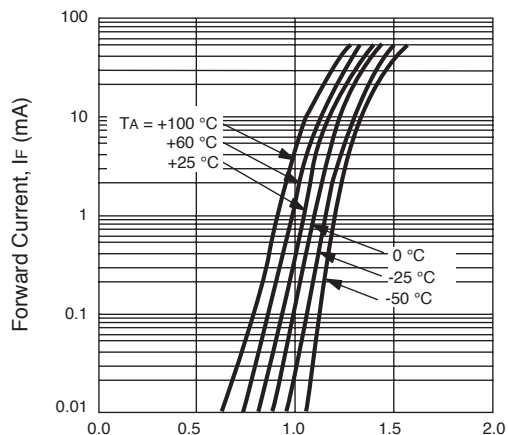

Forward Voltage, V_F (V)

COLLECTOR TO EMITTER DARK CURRENT vs. AMBIENT TEMPERATURE

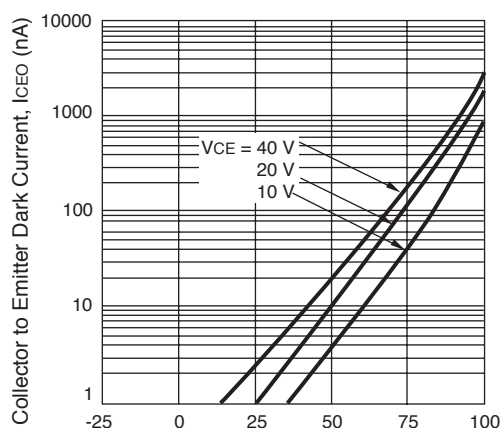

Ambient Temperature, T_A ($^\circ\text{C}$)

COLLECTOR CURRENT vs. COLLECTOR TO EMITTER VOLTAGE

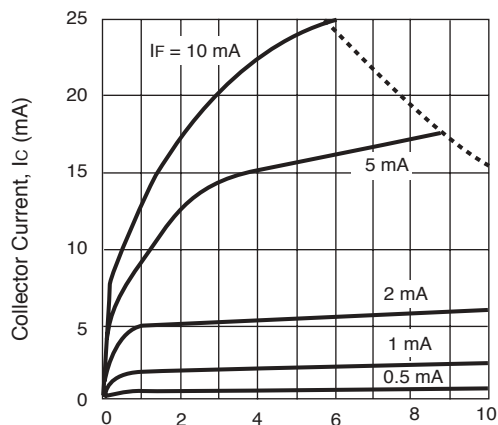

Collector to Emitter Voltage, V_{CE} (V)

COLLECTOR CURRENT vs. COLLECTOR SATURATION VOLTAGE

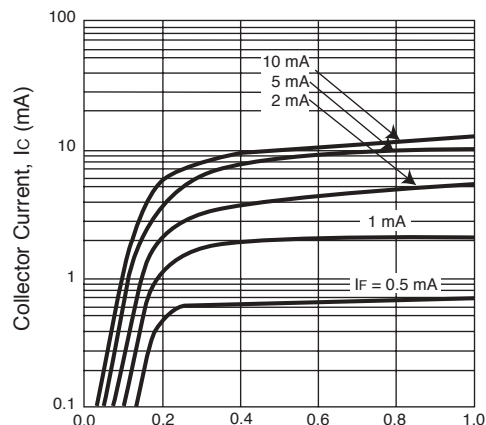

Collector Saturation Voltage, $V_{CE(sat)}$ (V)

TYPICAL PERFORMANCE CURVES (TA = 25 °C)

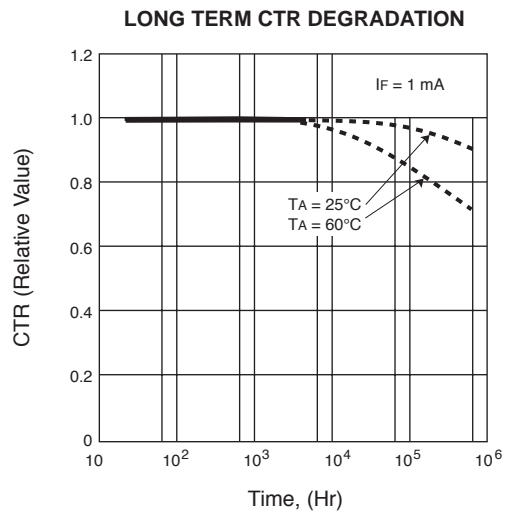
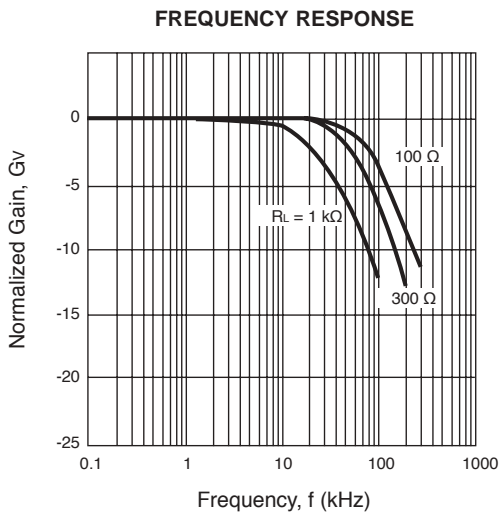
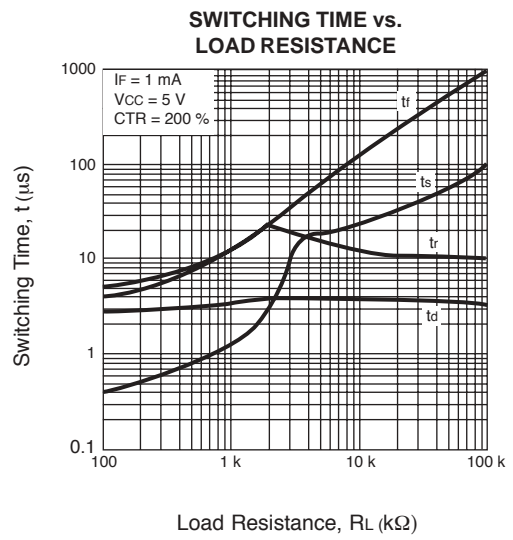
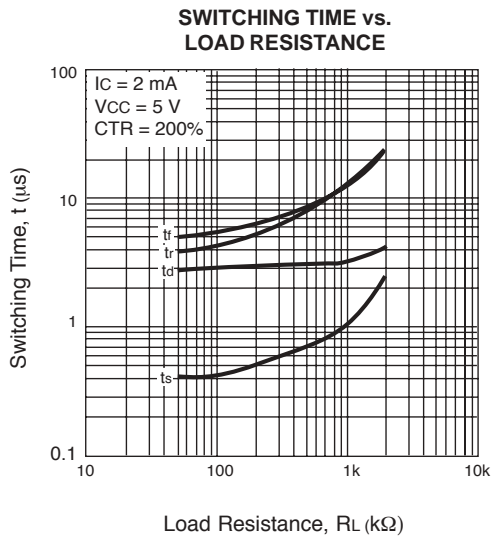
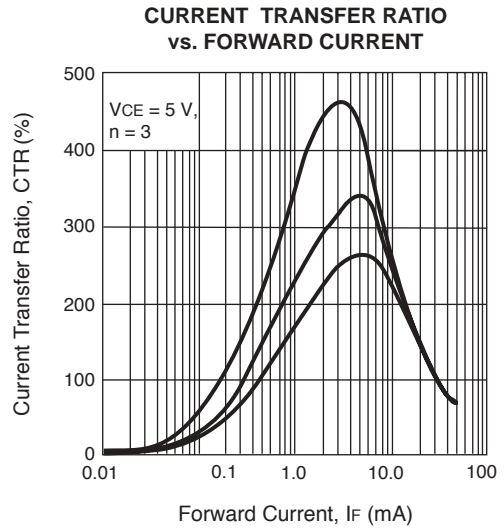
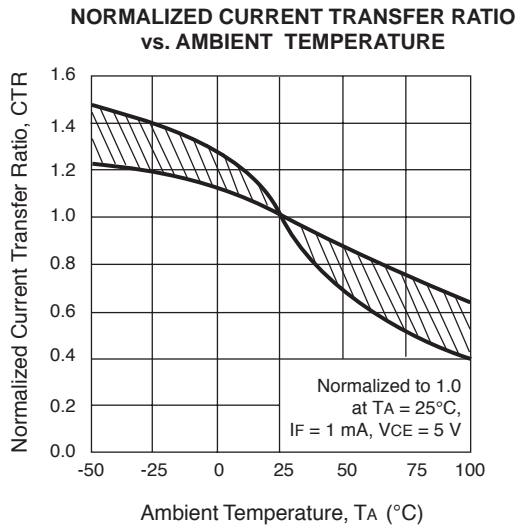

PS2711-1 TAPING SPECIFICATIONS (Units in mm)

Outline and Dimensions (Tape)

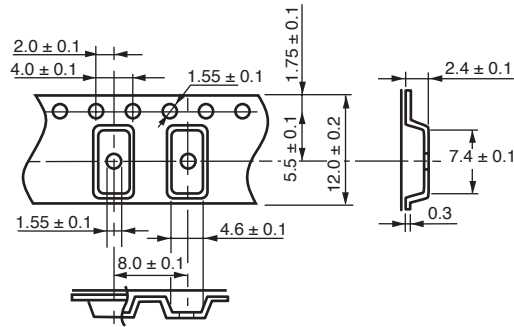

Tape Direction

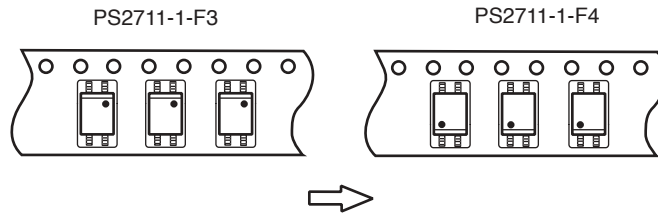

Outline and Dimensions (Reel)

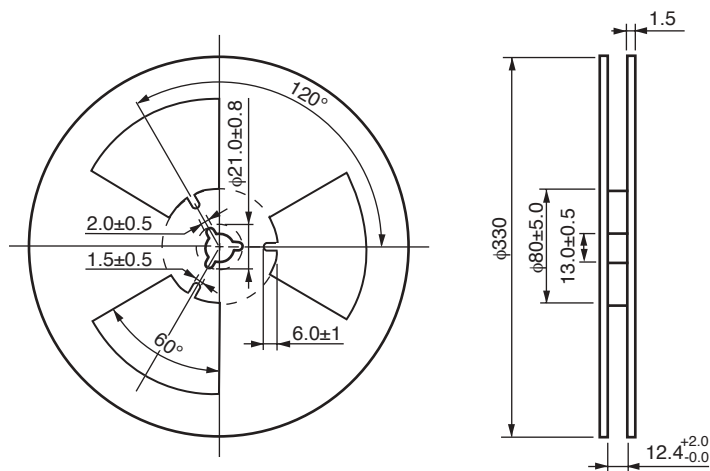

Packing: 3500 pcs/reel

RECOMMENDED SOLDERING CONDITIONS

(1) Infrared reflow soldering

- Peak reflow temperature 235 °C or below (package surface temperature)
- Time of temperature higher than 210 °C 30 seconds or less
- Number of reflows Three
- Flux Rosin flux containing small amount of chlorine
(The flux with a maximum chlorine content of 0.2 Wt % is recommended.)

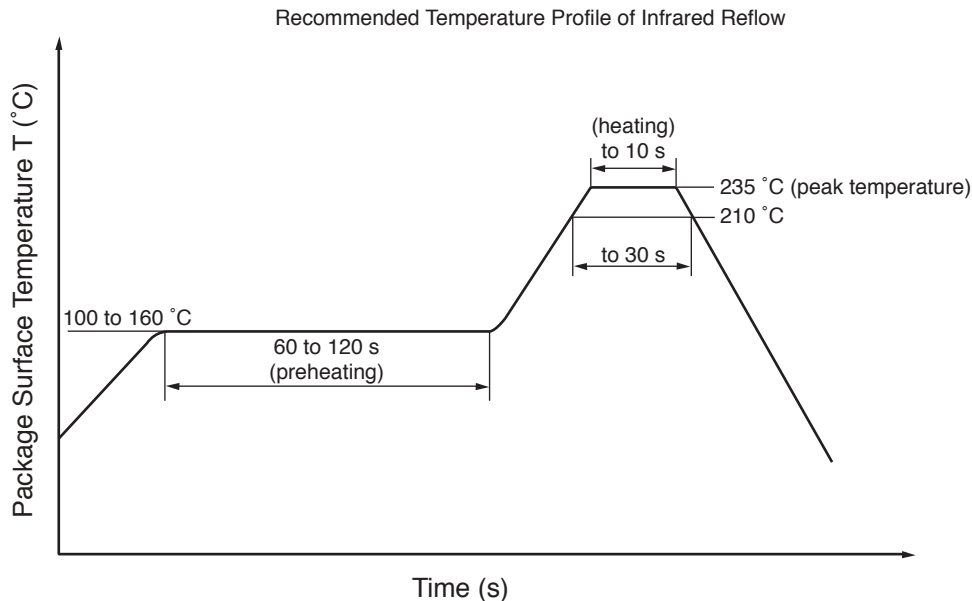

(2) Dip soldering

- Temperature 260 °C or below (molten solder temperature)
- Time 10 seconds or less
- Number of times One (Allowed to be dipped in solder including plastic mold portion)
- Flux Rosin flux containing small amount of chlorine
(The flux with a maximum chlorine content of 0.2 Wt % is recommended.)

(3) Cautions

- Fluxes
Avoid removing the residual flux with freon-based cleaning solvent.
- Noise
Be aware that when voltage is applied suddenly between the photocoupler's input and output or between collector-emitters at startup, the output side may enter the on state even if the voltage is within the absolute maximum ratings.

Life Support Applications

These NEC products are not intended for use in life support devices, appliances, or systems where the malfunction of these products can reasonably be expected to result in personal injury. The customers of CEL using or selling these products for use in such applications do so at their own risk and agree to fully indemnify CEL for all damages resulting from such improper use or sale.

CEL California Eastern Laboratories, Your source for NEC RF, Microwave, Optoelectronic, and Fiber Optic Semiconductor Devices.

4590 Patrick Henry Drive • Santa Clara, CA 95054-1817 • (408) 988-3500 • FAX (408) 988-0279 • www.cel.com

DATA SUBJECT TO CHANGE WITHOUT NOTICE

10/14/2003