

Descriptions

- Three Terminal Positive Low Dropout Voltage Regulator

Features

- Low Standby Current Consumption (500 μ A Typ.)
- Maximum Output Current (180 mA Max.)
- Less I/O voltage Difference (250 mV Max.)

Ordering Information

Type NO.	Marking	Package Code
S78DL33	S78DL33	TO-92

Outline Dimensions

unit : mm

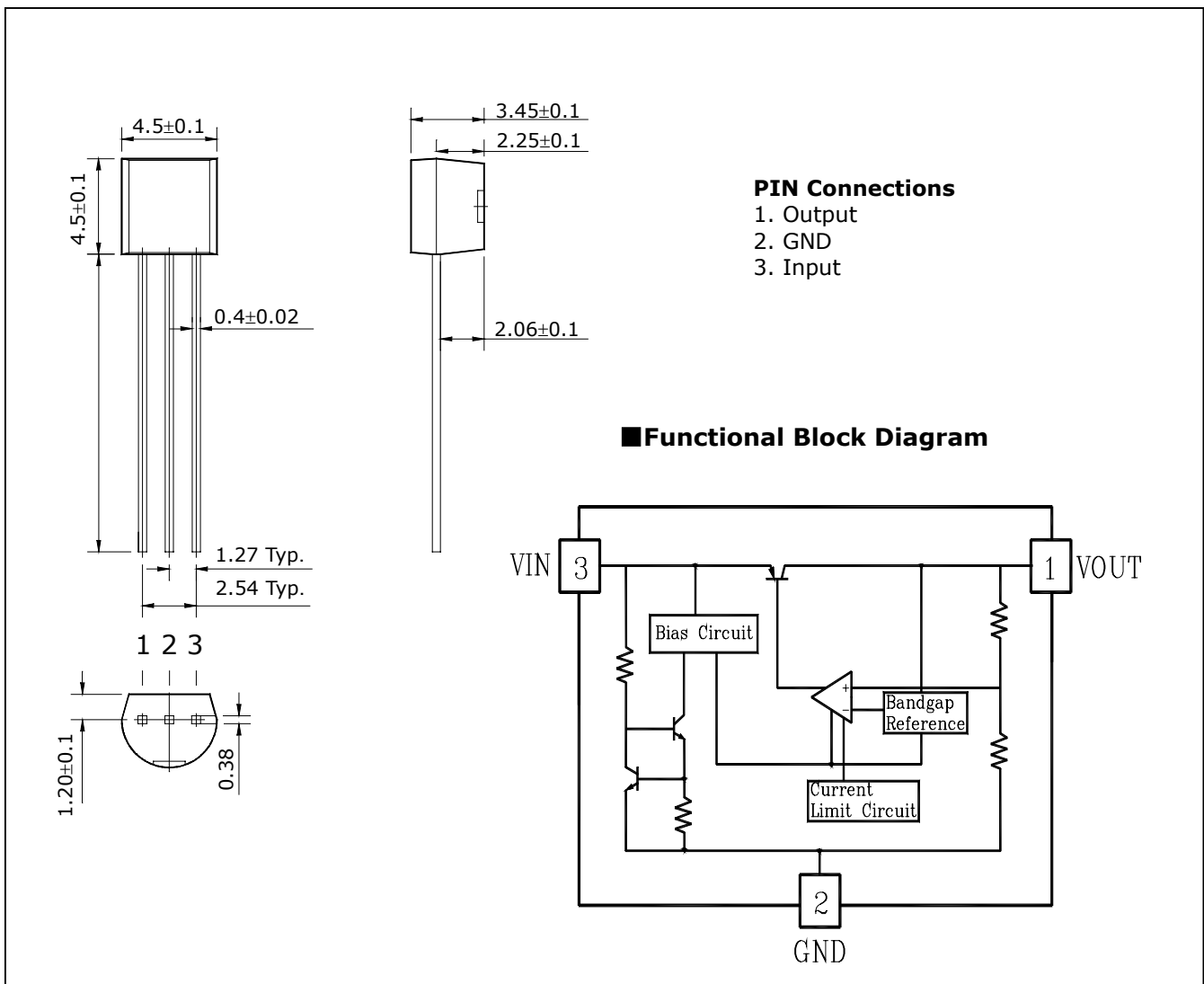

Maximum ratings

Ta=25°C

Characteristic	Symbol	Ratings	Unit
Operating Input voltage	V _{IN}	16	V
Power Dissipation	P _D	625	mW
Operating Temperature Range	T _{OPR}	-40~+85	°C
Junction Temperature	T _j	150	°C
Storage Temperature Range	T _{stg}	-55~150	°C
Lead Temperature Time	T _{sol}	260 (10 Sec)	°C

Electrical Characteristics

(※ V_{IN}=4.3V, I_{OUT}=100uA, T_j=25°C)

Characteristic	Symbol	Test Condition	Min.	Typ.	Max.	Unit
Output voltage	V _{OUT}	V _{IN} =4.3V, I _{OUT} =100uA	3.168	3.3	3.432	V
Voltage Regulation	Δ V _{OUT} (1)	V _{IN} =4.3V~10V, I _{OUT} =100uA	-	2	15	mV
Load Regulation	Δ V _{OUT} (2)	V _{IN} =4.3V, I _{OUT} =1~100mA	-	7	28	mV
Dropout Voltage	V _{DROP}	I _{OUT} =50mA	-	110	230	mV
		I _{OUT} =100mA	-	150	300	
Ripple Rejection Ratio	RR	f=100Hz, I _{OUT} =100uA	-	75	-	dB
Ground pin Current	I _{GND}	V _{IN} =4.3V, I _{OUT} =100uA		200	400	uA
		V _{IN} =4.3V, I _{OUT} =50mA		0.9	1.8	mA
		V _{IN} =4.3V, I _{OUT} =100mA		2.1	4	mA

Test circuit

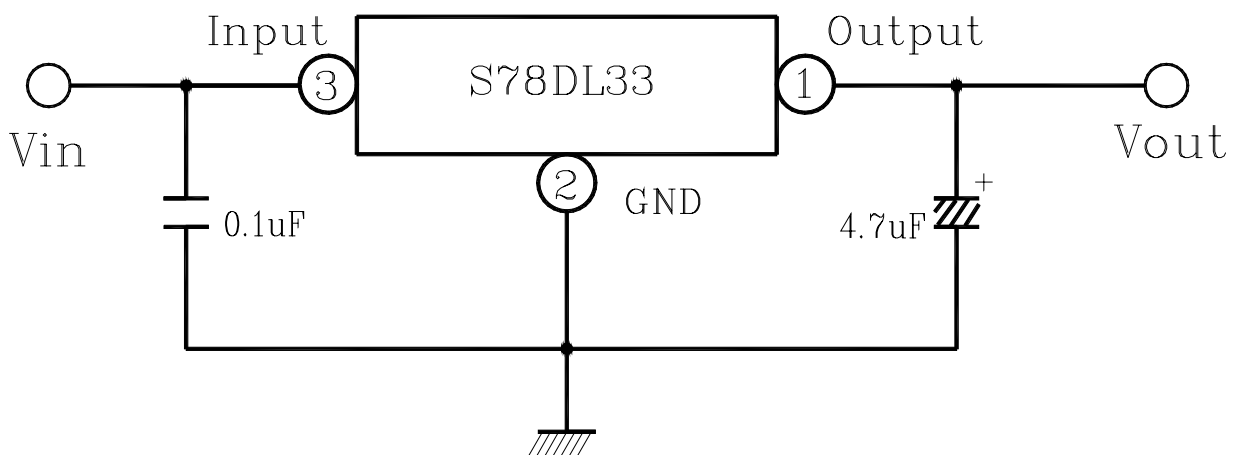

Electrical Characteristic Curves

Fig. 1. Vin - Vout

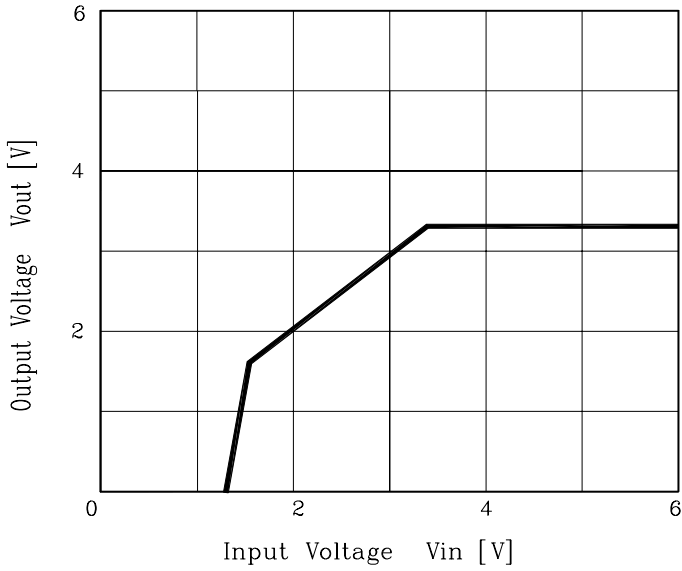

Fig. 2 |Vout - Vin| - I_{OUT}

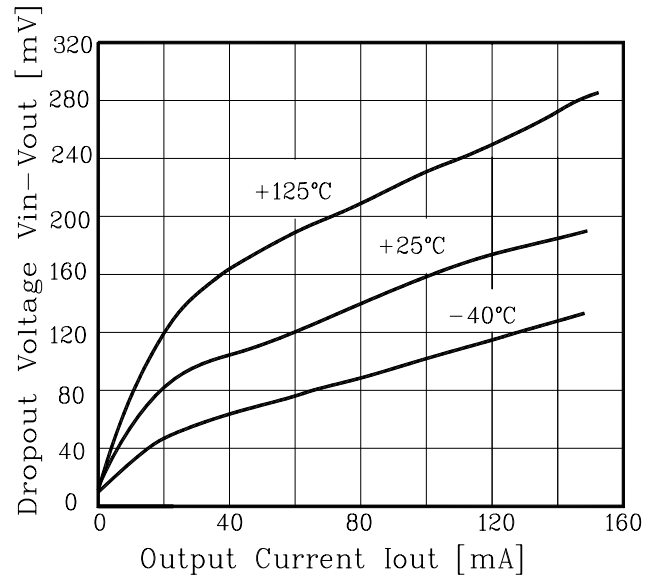

Fig. 3. Pd - Ta

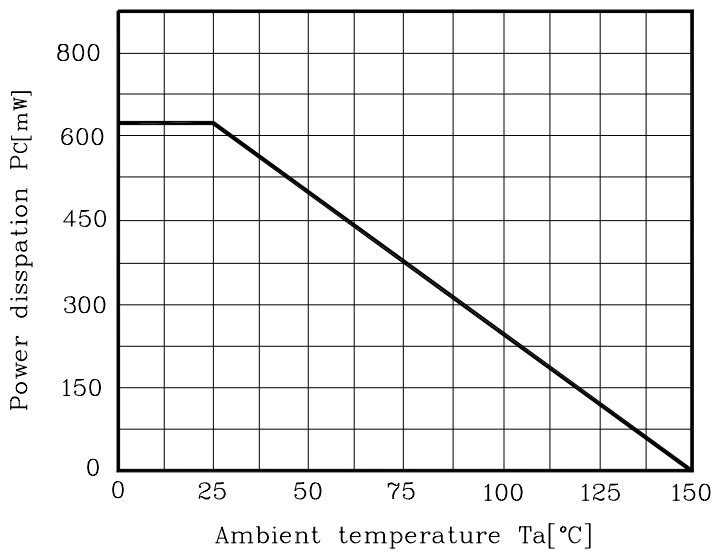

Fig. 4. Input voltage - Ground pin Current

