

4 X 50W STEREO **BASH**® POWER AMPLIFIER

- MONOCHIP BRIDGE QUAD CONFIGURABLE AMPLIFIER OPTIMIZED FOR BASH® ARCHITECTURE
- 4 X 50W OUTPUT POWER @ $R_L = 8 \Omega$, THD = 10% or (2 x 50W @ 8Ω + 1 x 100W @ 4Ω) or (2 x 100W @ 4Ω)
- PRECISION RECTIFIERS TO DRIVE THE BUCK REGULATOR
- ON-OFF SEQUENCE/ TIMER WITH MUTE AND STANDBY
- PROPORTIONAL OVER POWER OUTPUT CURRENT TO LIMIT THE BUCK REGULATOR
- ABSOLUTE POWER BRIDGE OUTPUT TRANSISTOR POWER PROTECTION
- ABSOLUTE OUTPUT CURRENT LIMIT
- INTEGRATED THERMAL PROTECTION
- POWER SUPPLY OVER VOLTAGE

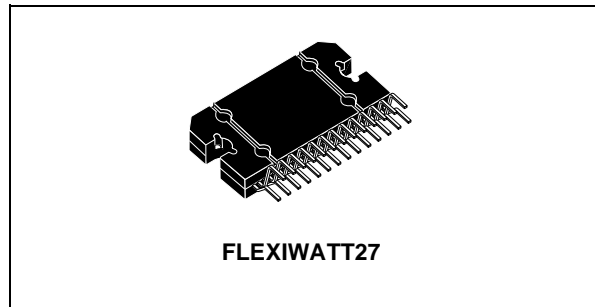

PROTECTION

- FLEXIWATT POWER PACKAGE WITH 27 PIN
- **BASH**® LICENCE REQUIRED

DESCRIPTION

The STA530 is a BASH® power amplifier where BASH® means “High Efficiency”.

BLOCK DIAGRAM

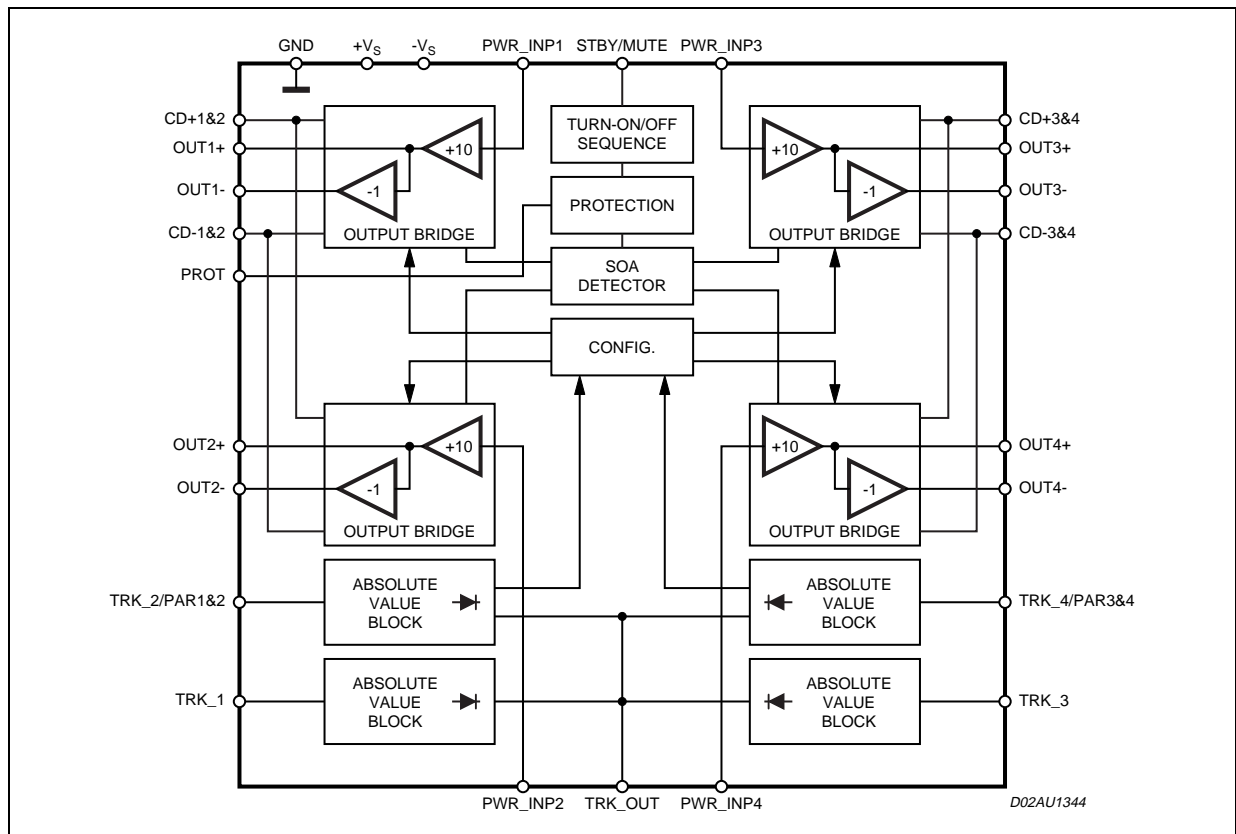

DESCRIPTION (continued)

In fact it's permits to build a BASH® architecture amplifier adding only few external components and a variable Buck regulator tracking the audio signal. Notice that normally only one Buck regulator is used to supply a multichannel amplifiers system , therefore most of the functions implemented in the circuit have a summing output pin.

The signal circuits are biased by fixed negative and positive voltages referred to Ground. Instead the final stages of the output amplifiers are supplied by two external voltages that are following the audio signal . In this way the headroom for the output transistors is kept at minimum level to obtain a high efficiency power amplifier.

The circuit contains all the blocks to build a configurable four channel amplifier.

The tracking signal for the external Buck regulator is generated from the Absolute Value Block (AVB) that rectifies the audio signal. The outputs of these blocks are decoupled by a diode to permit an easy sum of this signal for the multichannel application. The gain of the stage AVB is equal to 70 (+36.9 dB). A sophisticated circuit performs the output transistor power detector that , with the buck regulator, reduces the power supply voltage . Moreover, a maximum current output limiting and the over temperature sensor have been added to protect the circuit itself. The external voltage applied to the STBY/MUTE pin forces the two amplifiers in the proper condition to guarantee a silent turn-on and turn-off.

ABSOLUTE MAXIMUM RATINGS

Symbol	Parameter	Value	Unit
+V _s	Positive supply voltage referred to pin 14 (GND)	27	V
-V _s	Negative supply voltage referred to pin 14 (GND)	-27	V
V _{CD+}	Positive supply voltage tracking rail referred to pin 14 (GND)	20	V
V _{CD-}	Negative supply voltage referred to -V _s ⁽¹⁾	-0.3	V
V _{CD-}	Negative supply voltage tracking rail referred to pin 14 (GND)	-20	V
V _{PWR_Imp1} V _{PWR_Imp2} V _{TRK_1} V _{TRK_2}	Pin 11, 10, 9, 8 Negative & Positive maximum voltage referred to GND (pin 14)	-25 to +25	V
V _{PWR_Imp3} V _{PWR_Imp4} V _{TRK_3} V _{TRK_4}	Pin 17, 18, 19, 20 Negative & Positive maximum voltage referred to GND (pin 14)	-25 to +25	V
I _{STBY-max}	Pin 12 maximum input current (Internal voltage clamp at 5V)	500	µA
V _{STBY/MUTE}	Pin 12 negative maximum voltage referred to GND (pin 14)	-0.5	V

Notes: 1. V_{CD-} must not be more negative than -V_s

THERMAL DATA

Symbol	Parameter	Value	Unit
T _j	Max Junction temperature	150	°C
R _{th_j-case}	Thermal Resistance Junction to case	max 1	°C/W

OPERATING RANGE

Symbol	Parameter	Value	Unit
+V _s	Positive supply voltage	+15 to +25	V
-V _s	Negative supply voltage	-15 to -25	V
ΔV _{s+}	Delta positive supply voltage	5V ≤ (V _{s+} - V _{CD+}) ≤ 10V	V
V _{CD+}	Positive supply voltage tracking rail	+3 to +15	V
V _{CD-}	Negative supply voltage tracking rail	-15 to -3	V
T _{amb}	Ambient Temperature Range	0 to 70	°C
I _{sb_max}	Pin 12 maximum input current (Internal voltage clamp at 5V)	200	μA

PIN CONNECTION

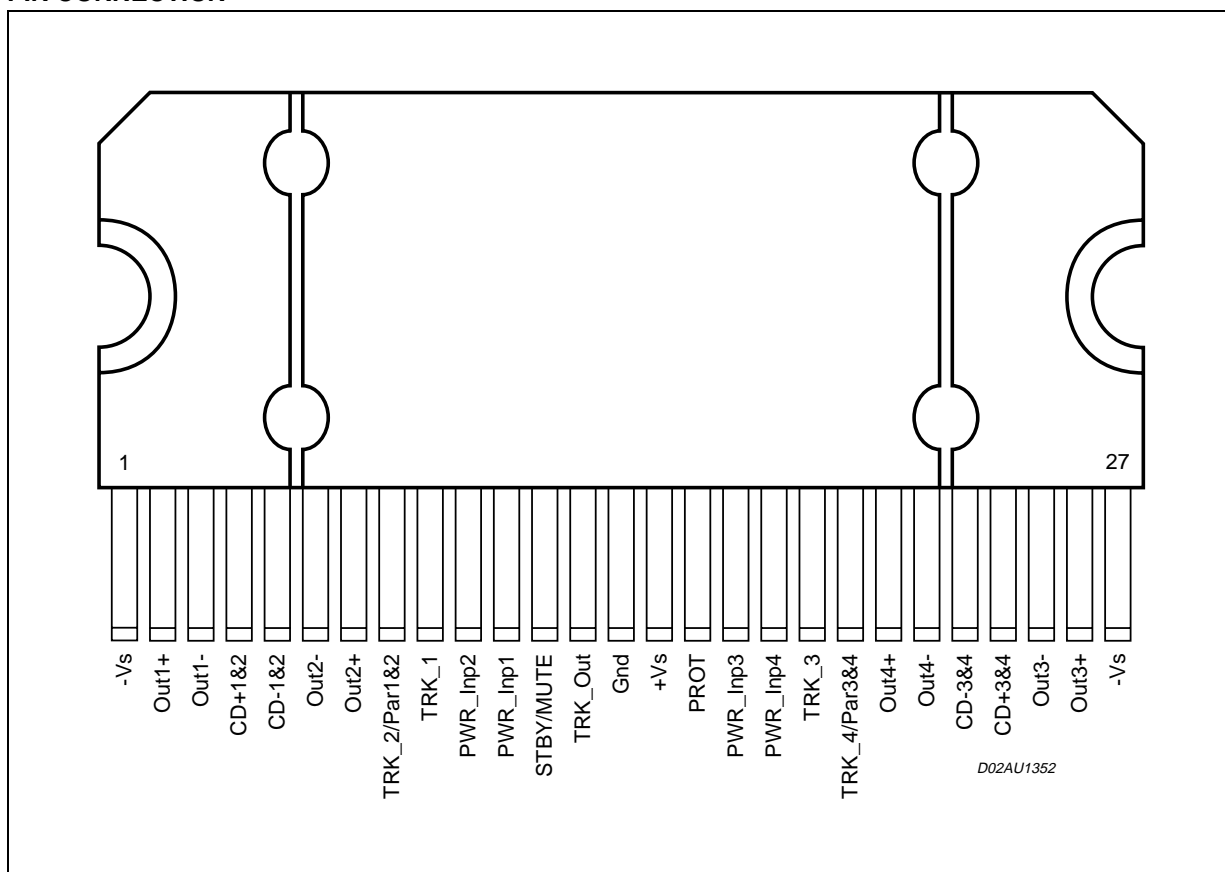

NOTE

Slug connected to PINS No. 1 & 27

PIN CONNECTION

N°	Name	Description
1	-Vs	Negative Bias Supply
2	Out1+	Channel 1 speaker positive output
3	Out1-	Channel 1 speaker negative output
4	CD+1&2	Channels 1 & 2 Time varying tracking rail positive power supply
5	CD-1&2	Channels 1 & 2 Time varying tracking rail negative power supply
6	Out2-	Channel 2 speaker negative output
7	Out2+	Channel 2 speaker positive output
8	TRK_2/ Par1&2	Absolute value block input for channel 2, and parallel command for channels 1&2
9	TRK_1	Absolute value block input for channel 1
10	PWR_Inp2	Input to channel 2 power stage
11	PWR_Inp1	Input to channel 1 power stage
12	STBY/MUTE	Standby/mute input voltage control
13	TRK_Out	Absolute value block output
14	Gnd	Analog Ground
15	+Vs	Positive Bias Supply
16	PROT	Channel Protection signal for STABP01
17	PWR_Inp3	Input to channel 3 power stage
18	PWR_Inp4	Input to channel 4 power stage
19	TRK_3	Absolute value block input for channel 3
20	TRK_4/ Par3&4	Absolute value block input for channel 4, and parallel command for channels 3&4
21	Out4+	Channel 4 speaker positive output
22	Out4-	Channel 4 speaker negative output
23	CD-3&4	Channels 3 & 4 Time varying tracking rail negative power supply
24	CD+3&4	Channels 3 & 4 Time varying tracking rail positive power supply
25	Out3-	Channel 3 speaker negative output
26	Out3+	Channel 3 speaker positive output
27	-Vs	Negative Bias Supply

ELECTRICAL CHARACTERISTICS (Test Condition: $V_{S+} = 25V$, $V_{S-} = -25V$, $V_{CD+} = 15V$, $V_{CD-} = -15V$, $R_L = 8\Omega$, external components at the nominal value $f = 1KHz$, $T_{amb} = 25^\circ C$ unless otherwise specified)

Symbol	Parameter	Test Condition	Min.	Typ.	Max.	Unit
TRACKING PARAMETERS						
G_{TRK}	Tracking reference voltage gain		66	70	74	
V_{TRK_out}	Tracking ref. output voltage		0	15		V
I_{TRK_out}	Current capability		5	6		mA
Z_{TRK_in}	Input impedance ($T_{RK1/2}$)			1		M Ω
V_{OFFSET}	Output tracking DC offset			100		mV
OUTPUT BRIDGE						
G_{out}	Half Output bridge gain		19	20	21	dB
G_{ch}	Output bridge differential gain		25	26	27	dB
ΔG_{ch}	Output bridges gain mismatch		-1		1	dB
P_{out}	Continuous Output Power	THD = 1%		39		W
		THD = 10%		50		W
		THD = 10% $R_L = 4\Omega$ $V_{CD+} = 11V$, $V_{CD-} = -11V$		40		W
P_{out} 2 ch par	Continuous Output Power	THD = 1% $R_L = 4\Omega$		78		W
		THD = 10% $R_L = 4\Omega$		100		W
THD	Total harmonic distortion of the output bridge	$P_o = 5W$		0.01	0.1	%
		$f = 20Hz$ to $20KHz$; $P_o = 20W$			0.2	%
V_{off}	Output bridge D.C. offset		-100		100	mV
EN	Noise at Output bridge pins	$f = 20Hz$ to $20KHz$; $R_g = 50\Omega$		60		μV
Z_{br_in}	Input impedance		100	140	180	K Ω
R_{dson}	Output power R_{dson}	$I_o = 1A$ $T_j = 25^\circ C$		400	500	m Ω
$R_{dsonMAX}$	Maximum Output power R_{dson}	$I_o = 1A$		800		m Ω
OLG	Open Loop Voltage Gain			100		dB
GB	Unity Gain Bandwidth			6		MHz
SR	Slew Rate			8		V/ μs
PROTECTION						
V_{STBY}	Stby voltage range		0		0.8	V
V_{MUTE}	Mute voltage range		1.6		2.5	V
V_{PLAY}	Play voltage range		4		5	V
T_{h1}	First Over temperature threshold			130		$^\circ C$

ELECTRICAL CHARACTERISTICS (continued)

Symbol	Parameter	Test Condition	Min.	Typ.	Max.	Unit
T _{h2}	Second Over temperature threshold			150		°C
Unbal. Ground	Upper Unbalancing ground threshold	Referred to (CD ⁺ - CD ⁻)/2		5		V
Unbal. Ground	Lower Unbalancing ground threshold	Referred to (CD ⁺ - CD ⁻)/2		-5		V
UV _{th}	Under voltage threshold	Vs ⁺ + Vs ⁻	18		22	V
P _{d_reg.}	Power dissipation threshold for system regulation	I _{prot} = 50μA; @ V _{ds} = 8V	18	20	23	W
P _{d_max}	Switch off power dissipation threshold	@ V _{ds} = 8V		30		W
I _{prot Pd}	Protection current slope	for Pd > P _{d_reg}		400		μA/W
I _{prot Id}	Protection current slope	for Id > I _{d_reg}		400		μA/A
I _{lct s}	Limiting Current threshold "soft"		4	4.5	5	A
I _{lct h}	Limiting Current threshold "hard"		4.5	5	5.5	A
I+Vs	Positive supply current	Stby (V _{stby/mute} pin = 0V) Mute (V _{stby/mute} pin = 2.5V) Play (V _{stby/mute} pin = 5V no signal)		5 TBD TBD		mA mA mA
I-Vs	Negative supply current	Stby (V _{stby/mute} pin = 0V) Mute (V _{stby/mute} pin = 2.5V) Play (V _{stby/mute} pin = 5V no signal)		6 29 33		mA mA mA
ICD+	Positive tracking rail supply current	Stby (V _{stby/mute} pin = 0V) Mute (V _{stby/mute} pin = 2.5V) Play (V _{stby/mute} pin = 5V no signal)		200 85 85		μA mA mA
ICD-	Negative tracking rail supply current	Stby (V _{stby/mute} pin = 0V) Mute (V _{stby/mute} pin = 2.5V) Play (V _{stby/mute} pin = 5V no signal)		200 85 85		μA mA mA

FUNCTIONAL DESCRIPTION

The circuit contains all the blocks to build a configurable four channel amplifier.

In fact, only driving properly the TRK_2 (and TRK_4) pins, it's possible to change the chip configuration:

- 50 Watt x 4
- 50 Watt x 2 + 100 Watt x1 (TRK_2/Par1&2 or TRK_4/Par3&4 at -Vs)
- 100 Watt x 2 (TRK_2/Par1&2 and TRK_4/Par3&4 at -Vs)

Each single channel is based on the Output Bridge Power Amplifier, and its protection circuit. Moreover, a signal rectifier are added to complete the circuit.

The operation modes are driven by The Turn-on/off sequence block. In fact the IC can be set in three states by the Stby/mute pin:

STANDBY ($V_{pin} < 0.8V$), MUTE ($1.6V < V_{pin} < 2.5V$), and PLAY ($V_{pin} > 4V$).

In the Standby mode all the circuits involved in the signal path are uninhabited, instead

in Mute mode the circuits are biased but the Speakers Outputs are forced to ground potential.

These voltages can be get by the external RC network connected to Stby/Mute pin.

The same block is used to force quickly the I.C. In standby mode or in mute mode when the I.C. dangerous condition has been detected. The RC network in these cases is used to delay the Normal operation restore.

The protection of the I.C. are implemented by the Over Temperature, Unbalance Ground, Output Short circuit, Under voltage, and output transistor Power sensing as shown in the following table:

Table 1. Protection Implementation

Fault Type	Condition	Protection strategy	Action time	Release time
Chip Over temperature	$T_j > 130\text{ }^\circ\text{C}$	Mute	Fast	Slow Related to Turn_on sequence
Chip Over temperature	$T_j > 150\text{ }^\circ\text{C}$	Standby	Fast	Slow, Related to Turn_on sequence
Unbalancing Ground	$ V_{gnd} > ((CD+) - (CD-))/2 + 5V$	Standby	Fast	Slow, Related to Turn_on sequence
Over Current	$I_{out} > 4.5A$	Reducing Buck regulator output voltage.	Related to the Buck regulator	Related to the Buck regulator
Short circuit	$I_{out} > 5A$	Standby	Fast	Slow, related to Turn_on sequence
Under Voltage	$ V_{s+} + V_{s-} < 20V$	Standby	Fast	Slow, related to Turn_on sequence
Extra power dissipation at output transistor	$P_{d\ tr.} > 18W$	Reducing Buck regulator output voltage.	Related to the Buck regulator	Related to the Buck regulator
Maximum power dissipation at output transistor	$P_{d\ tr.} > 30W$	Standby	Fast	Slow, related to Turn_on sequence

ABSOLUTE VALUE BLOCK

The absolute value block rectifies the signal to extract the control voltage for the external Buck regulator. The output voltage swing is internally limited, the gain is internally fixed to 70.

The input impedance of the rectifier is very high , to allow the appropriate filtering of the audio signal before the rectification.

OUTPUT BRIDGE

The Output bridge amplifier makes the single-ended to Differential conversion of the Audio signal using two power amplifiers, one in non-inverting configuration with gain equal to 10 and the other in inverting configuration with unity gain. To guarantee the high input impedance at the input pins, PWR_Inp1....4, the second amplifier stages are driven by the output of the first stages respectively.

In 60W x2 channel configuration the "slave" inputs (INPUT 2/4) must be connected to GND.

POWER PROTECTION

To protect the output transistors of the power bridge a power detector is implemented (fig 1).

The current flowing in the power bridge and the voltage drop on the relevant power (Vds) are internally measured. These two parameters are converted in current and multiplied: the resulting current, I_{pd}, is proportional to the instantaneous dissipated power on the relevant output transistor. The current I_{pd} is compared with the reference current I_{pda}, if bigger (dissipated power > 18W) a current, I_{prot}(P_D), is supplied to the Protection pin. The aim of the current I_{prot} is to reduce the reference voltage for the Buck regulator supplying the power stage of the chip, and than to reduce the dissipated power. The response time of the system must be less than 200 μSec to have an effective protection. As further protection, when I_{pd} reaches an higher threshold (when the dissipated value is higher then 30W) the chip is shut down, forcing low the Stby/Mute pin, and the turn on sequence is restarted. The above description is relative for each channel in 4x30W configuration.

Figure 1. Power Protection Block Diagram

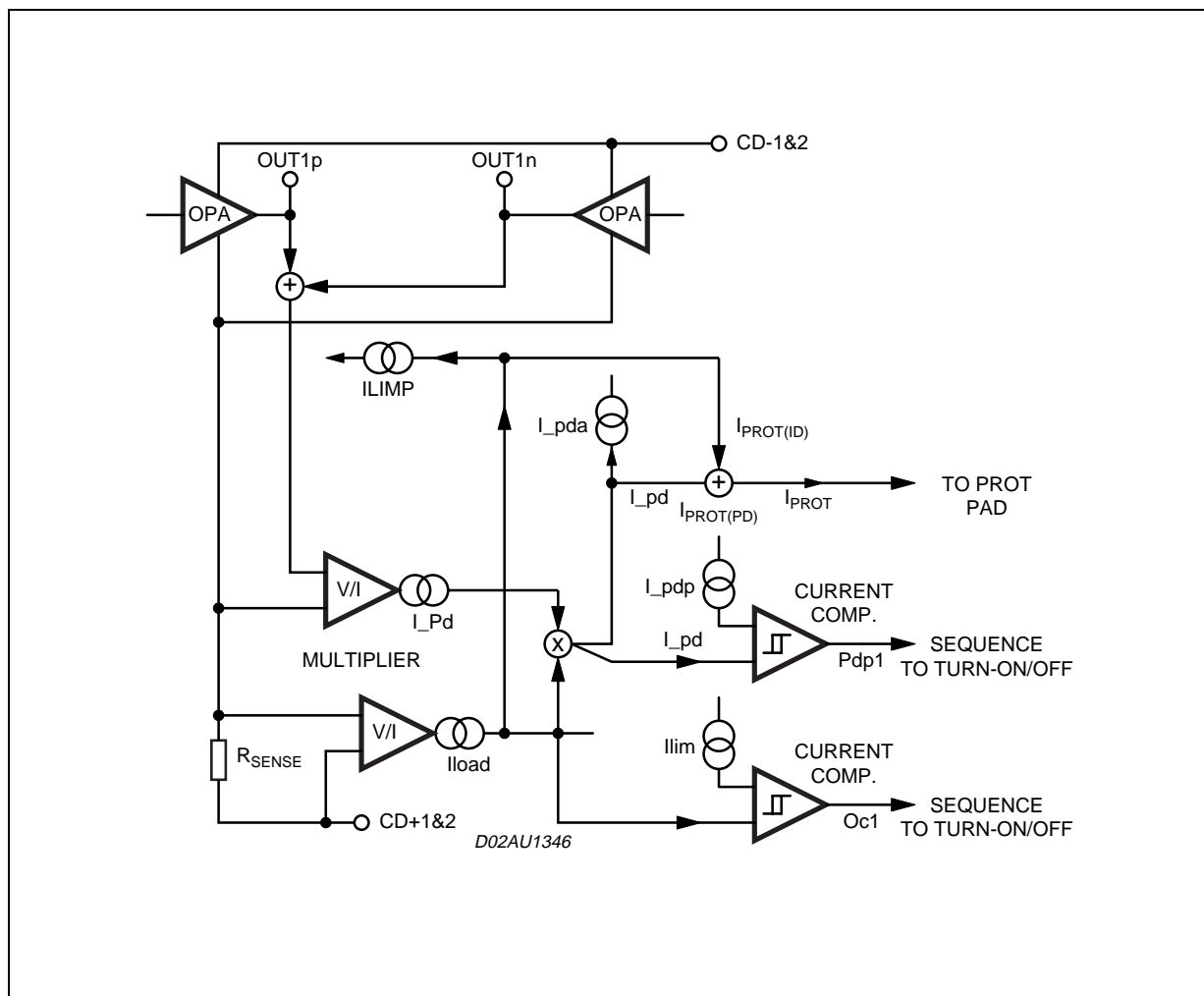

In fig. 2 there is the power protection strategy pictures. Under the curve of the 18W power, the chip is in normal operation, over 30W the chip is forced in Standby. This last status would be reached if the Buck regulator does not respond quickly enough reducing the stress to less than 30W.

The fig.3 gives the protection current, $I_{prot}(P_D)$, behavior. The current sourced by the pin Prot follows the formula:

$$I_{prot}(P_D) \equiv \frac{(P_d - P_{d_av_th}) \cdot 5 \cdot 10^{-4}}{1.25V}$$

(for each channel)

for $P_d < P_{d_av_th}$ the $I_{prot}(P_D) = 0$.

Figure 2. Power protection threshold

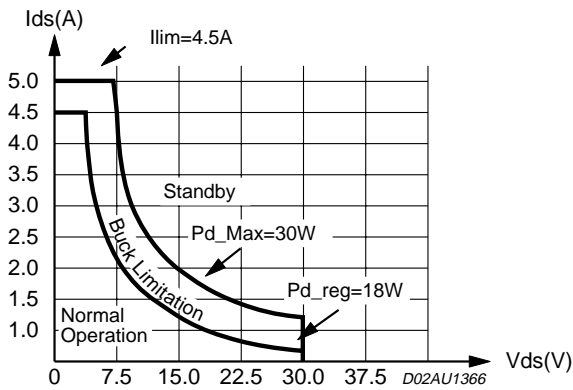
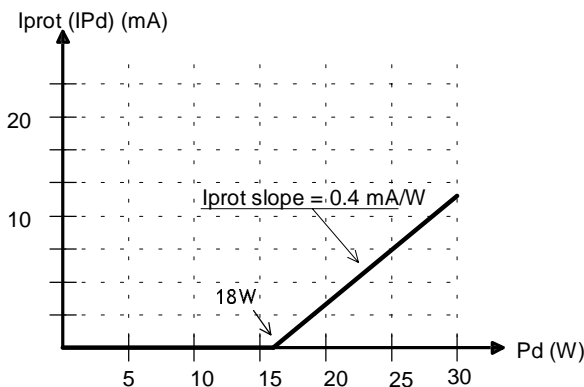

Figure 3. Protection current behaviour $I_{prot}(P_D)$



CURRENT PROTECTION

The chip is also protected by a current detection.

The current I_{LOAD} is compared with the reference current I_{LIMP} , if bigger ($I_{LOAD} > 4,5 A$) a current $I_{prot}(I_L)$, is supplied to the Protection pin.

As further protection, when I_{LOAD} reaches an higher threshold (5 A) the chip is shut down, forcing low the Stby/Mute pin, and the turn on sequence is restarted.

The above description is relative for each channel in 4x30W configuration.

The fig.4 gives the protection current, $I_{prot}(I_L)$, behavior. The current sourced by the pin Prot follows the formula:

$$I_{prot}(I_L) \equiv \frac{(I_{LOAD} - I_{ict,s})}{2500}$$

(for each channel)

for $I_{LOAD} < I_{ict,s}$ the $I_{prot}(I_L) = 0$.

For the parallel channel I_{prot} is double.

The chip is also shut down in the following conditions:

When the average junction temperature of the chip reaches 150°C.

When the ground potential differ from more than 5V from the half of the power supply voltage, $((CD+) - (CD-))/2$

When the sum of the supply voltage $|Vs+| + |Vs-| < 20V$

The output bridge is muted when the average junction temperature reaches 130°C.

Figure 4. Protection current behaviour $I_{prot}(I_L)$

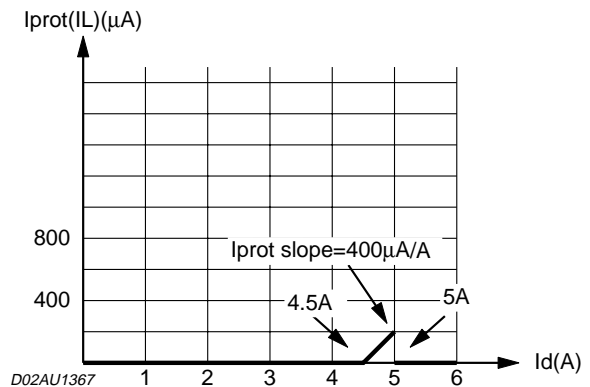

Figure 5. Test and Application Circuit (4x50W)

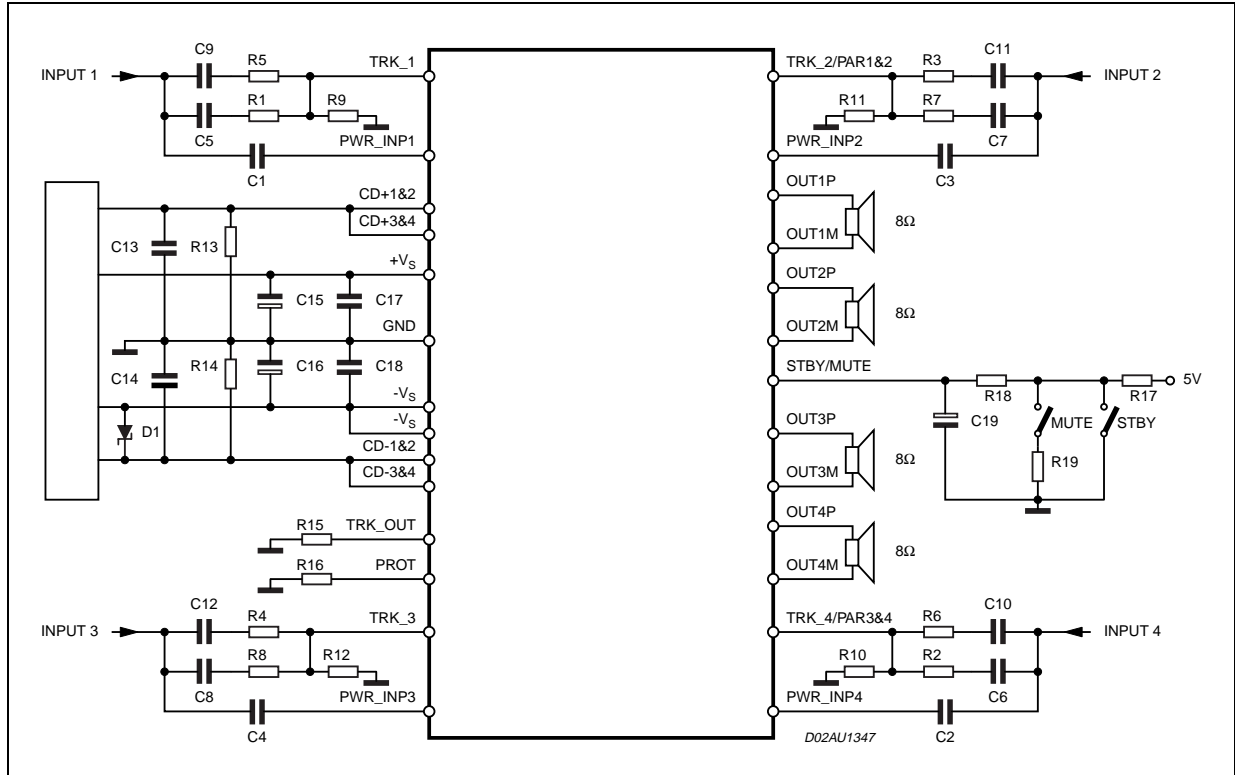
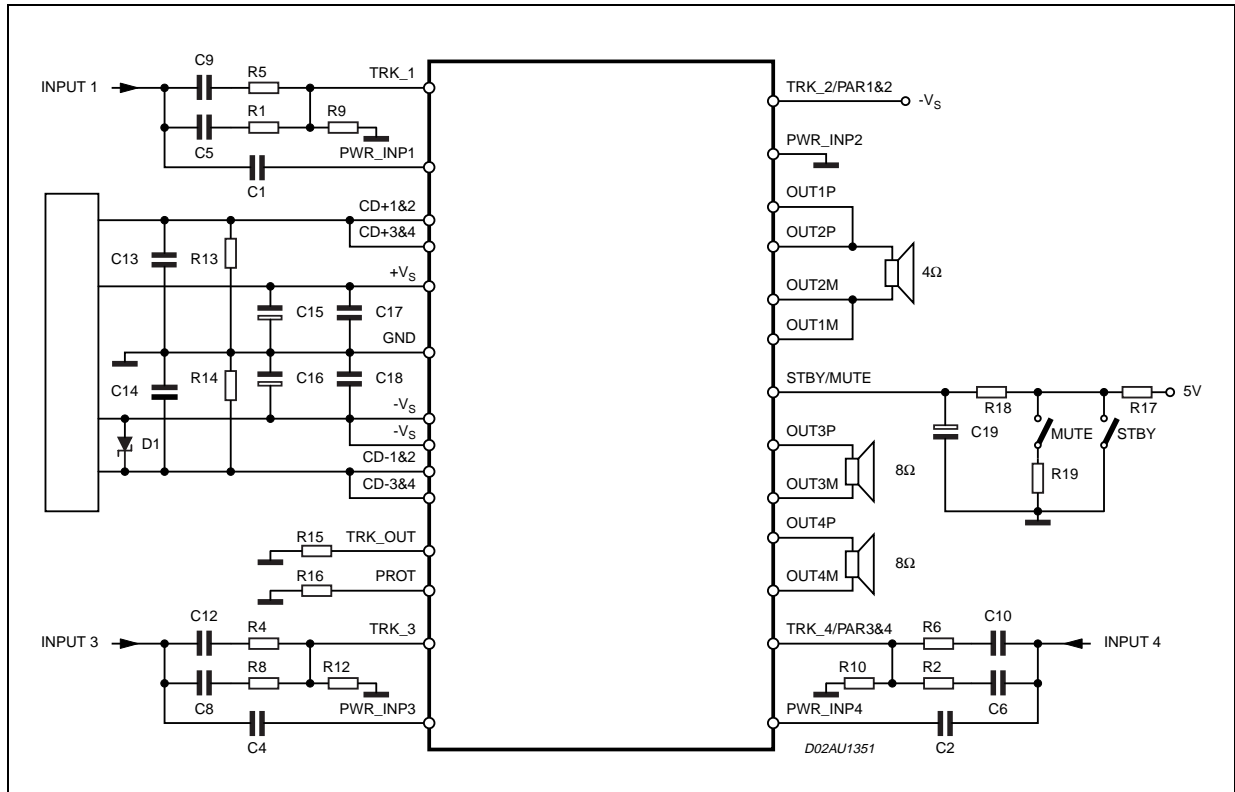

Figure 6. Test and Application Circuit (2x50W & 1x100W)



EXTERNAL COMPONENTS

Name	Function	Value	Formula
R1 = R2 = R7 = R8	Resistor for tracking input voltage filter	10KΩ	
R5 = R6 = R3 = R4	Resistor for tracking input voltage filter	56KΩ	
Cac C1 = C2 = C3 = C4	AC Decoupling capacitor	100nF (fp = 16Hz, Rac = 100KΩ)	$C_{ac} = \frac{1}{2\pi \cdot fp \cdot R_{ac}}$
R9=R10=R11=R12	Resistor for tracking input voltage filter	10KΩ	
C5 = C6 = C7 = C8	Capacitor for Tracking input voltage filter	1nF	
C9=C10=C11=C12	Dc decoupling capacitor	1μF	
R17	Bias Resistor for Stby/Mute function	10KΩ	
R18	Stby/Mute constant time resistor	30KΩ	
R19	Mute resistor	30KΩ	
C19	Capacitor for Stby/Mute resistor	2.2μF	
C17 = C18	Power supply filter capacitor	100nF	
R13 = R14	Centering resistor	330 Ω 1W	
C13 = C14	Tracking rail power supply filter	680nF	
R15	TRK_out	40KΩ	
R16	Protection	1KΩ	
C15 = C16	Power supply filter capacitor	470 μF , 63V	
D1	Schottky diode	SB360	

Figure 7. BASH® module SAM261 6.1 with 2 x STA530 (see Application Note AN1643)

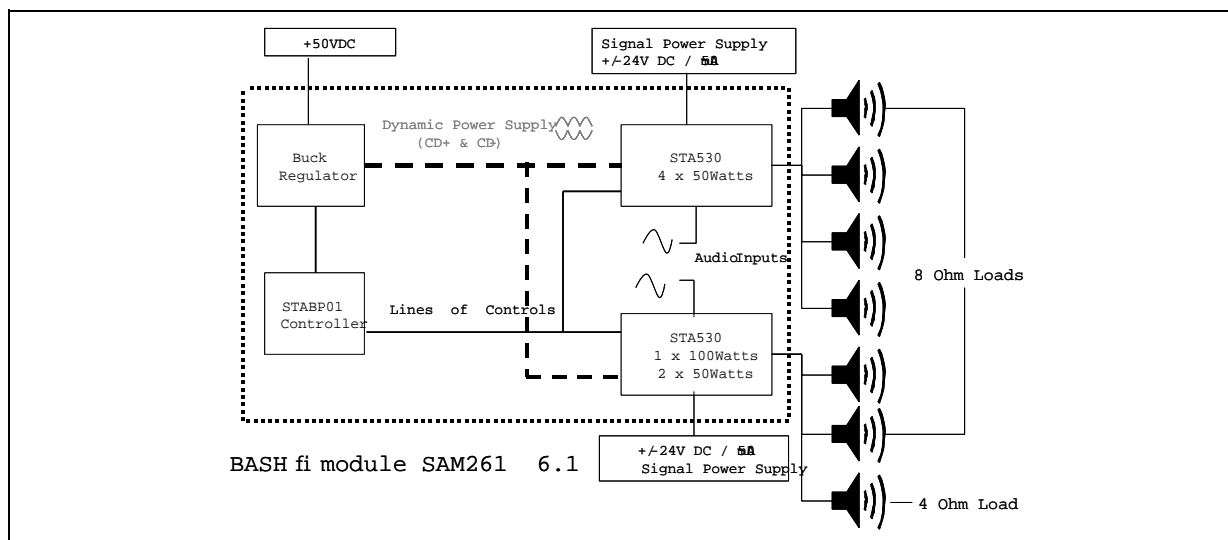

Power - On-Off sequences:

In order to avoid damages to the SAM261 board it is important to follow these sequences:

At **Power-On** apply in the first the **Auxiliary Power Supply (±24V)** and after the **Main Power Supply (+50V)**, in this condition the system is in "Mute state" and it can move in "play state" with the switch present on the pcb.

At **Power-Off** is better to bring the SAM module in "Mute state" and after that to follow this order: switch-off the **Main Supply Voltage (+50V)** and subsequently the **Auxiliary Power Supply. (±24V)**.

System Description & Operating Rules

SAM261 is a BASH® 6.1 amplifier (6 x 50W, 1 x 100W) implementation utilizing the STA530 Integrated Circuit. Specifically designed for multi-channel implementation in DVD - HTIB systems, Multi-Media systems, Mini and Micro systems and Set Top boxes.

SAM261 is dimensioned to provide the maximum Output Power (THD=10 %) on two channels and instantaneously and 1/3 max Pout on the remaining Outputs, or 1/8 of max Pout continuous; this rule is important to define the main Power Supply size (+50V).

Buck Regulator Description

The function of the buck regulator is to efficiently convert an input voltage to a lower voltage by adjusting the ratio of the switching transistor's on-time to off-time. The resulting waveform is averaged by the output filter to recover an analog signal.

In the BASH amplifier this output is in effect split in half by centering it on the audio ground to provide CD+ and CD- rails.

To avoid the need for a high side driver for the transistor switch in the buck regulator the buck circuit recommended has the switch in the return path. Hence the gate drive circuit (part of the STPB01) is referenced to the negative return of the main supply that provides power for the buck regulator.

Interfacing STA530 to STPB01 (Feedback circuit)

This circuit produces a control signal current that is fed back to the STPB01 digital controller. The network used in this example compares the track signal (STA530 track out) to a fixed ratio of buck regulator's output (CD+) using a transistor. This method is effective because the controller's reference is the negative of the main DC supply, which is not referenced to audio ground.

The tracking signal is generated inside the STA530 (track out) by taking the absolute value of the pre-amp's output. The outputs of each channel and of each STA530 are then tied together in a diode-oring arrangement. This means that the highest of any given output is the output that determines the tracking signal.

The absolute value circuit inside the STA530 has gain. This makes it possible to use an RC network and a resistor divider to create a phase shift in the tracking signal at higher frequencies. This is also useful in optimizing the alignment of the buck regulator's output with the output signal of the bridge amplifier at high frequency.

This circuit first converts the buck switch current to a peak voltage. The control current is then converted to a voltage (using a resistor) and added to the peak voltage. By doing this, the buck is better able to maintain the desired headroom over a wide load range and output level.

Centering Network for CD + & CD- Rails

The power rail of a bridge amplifier has no current flowing through the ground node, as the load is not connected to ground. However there are several different small sources of dynamic and continuous ground currents flowing from either CD+ or CD- to support the function of various things such as the control signal to the STPB01 controller. The centering network prevents these currents from shifting the CD+/- rails away from center i.e. away from a symmetric split of the buck's output about ground. This is critical, even a small centering error requires an increase in headroom which results in a significant drop in output losses. In its simplest form the centering network could be a resistor divider from CD+ to CD- with its center tied to ground. As long as the impedance is low enough (for example 200Ω) this will swamp the smaller offset currents. It is helpful to put this kind of passive network on the board with the STA530 devices to help when testing this board on its own.

Power Amplifier Heatsink requirements

The heatsink requirements are dependent on several design goals. However there are two common references: Pink noise at 1/8 of full power, all channels loaded. This would approximate a system with all channels reproducing music at full volume with clipping occurring only occasionally. The second would be full power at 1kHz for 5 minutes after a one hour pre-soak at 1/8 power.

The worse of these two is the full power test. A conservative approach is to assume that the heatsink would come to thermal equilibrium after 5 minutes. Thus the Rth of the heatsink can be determined by:

$$R_{th} = \frac{T_{jmax} - T_{amb}}{P_d} - R_{th-j case} - R_{th case to heatsink}$$

For example in the STA530 the $R_{th jc}$ is 1°C/W. $R_{case-to-heatsink}$ with grease is about 0.5 °C/W. The maximum operating junction temperature is 130 °C, which for margin should be derated to 120 °C.

Buck Regulator Heatsink

The Buck regulator heatsink can be designed in a similar manner and does not change by varying power supply. In general the efficiency will be in the order of 85%. The thermal impedances from the junction(s) to the heatsink may be lower and the maximum operating temperature will be higher. Usually either the sub or the remaining channels are tested at full power. The result is that usually the Buck heatsink is about ¼ the size of the linear heatsink, but this can be strongly affected by the design.

Figure 8. PCBs AND COMPONENTS LAYOUT

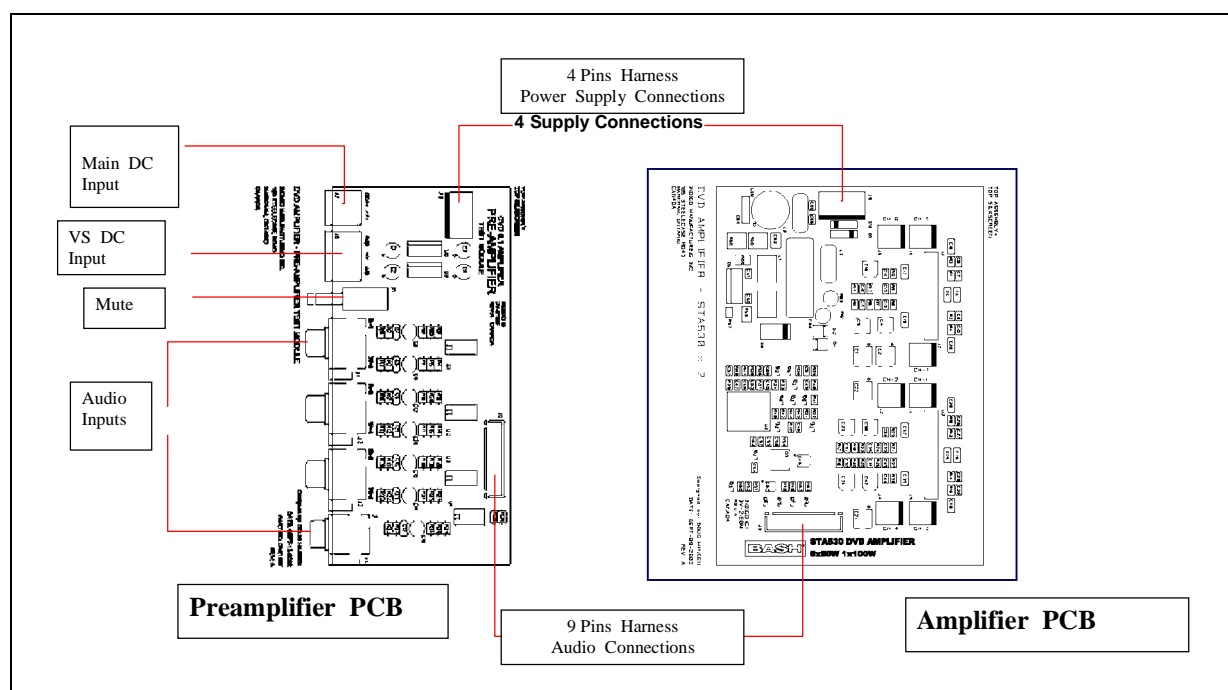

SAM261 Specification

Parameter	Rating	Notes
Output Power	Sats @ 8Ω - 55 Watts @ 10% Sub @ 4Ω - 100 Watts @ 10%	See Graphs
THD + N	< 0.05% @ 40 Watts < 0.05% @ 75 Watts	Measured @ 1KHZ
SNR	-102 dB (relative to full power) -110 dB (A-weighted)	Channel 5 terminated
Sensitivity	1 VRMS	Amplifier
Crosstalk	-87dB (relative to 10W)	Channel 5 @ 10W 1KHz 8Ω, Channel 3 input terminated
Main Power Supply Inputs	50Volts @ 2 Amps	Maximum Voltage is 50Vdc Minimum Voltage is 40Vdc
Aux Power Supply Inputs	+ 24 Volts @ 100mA -24 Volts @ 100mA	

Figure 9. THD + N FR Channel

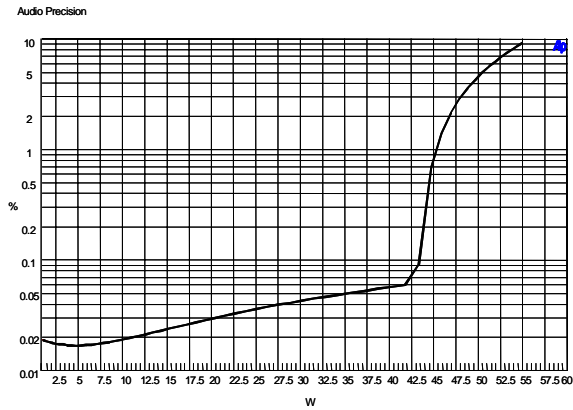

Figure 12. THD + N LF Channel

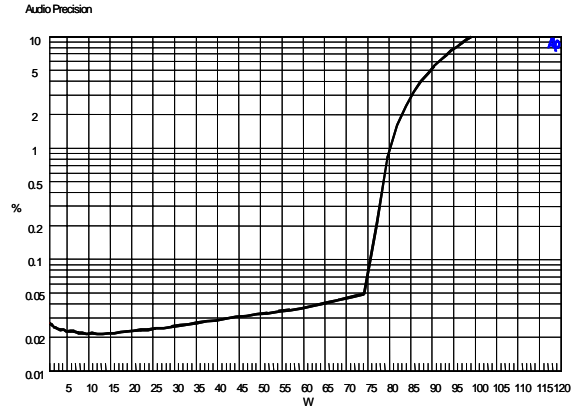

Figure 10. THD + N vs Frequency

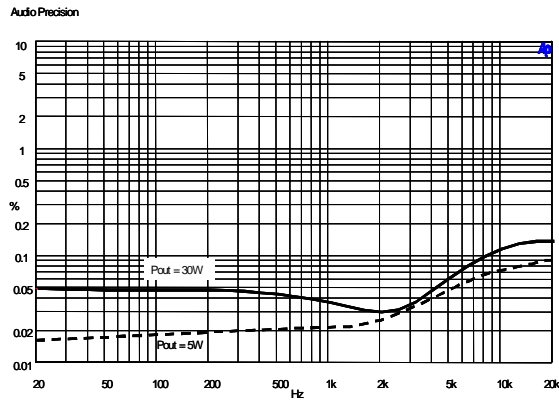

Figure 13. Frequency Response

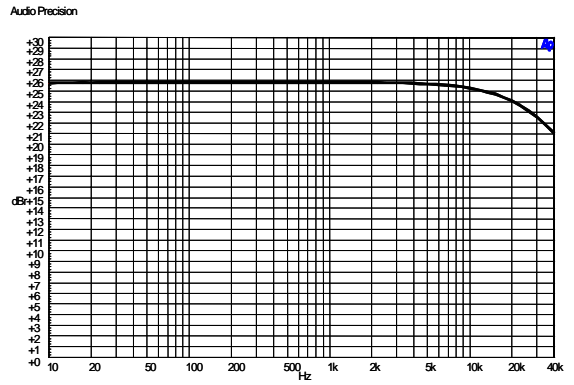

Figure 11. Residual Noise vs Freq - Relative to full power

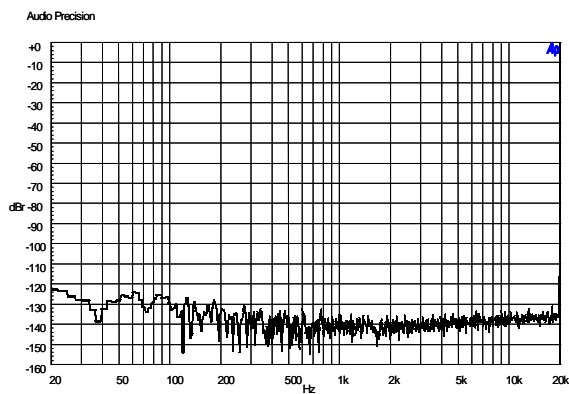
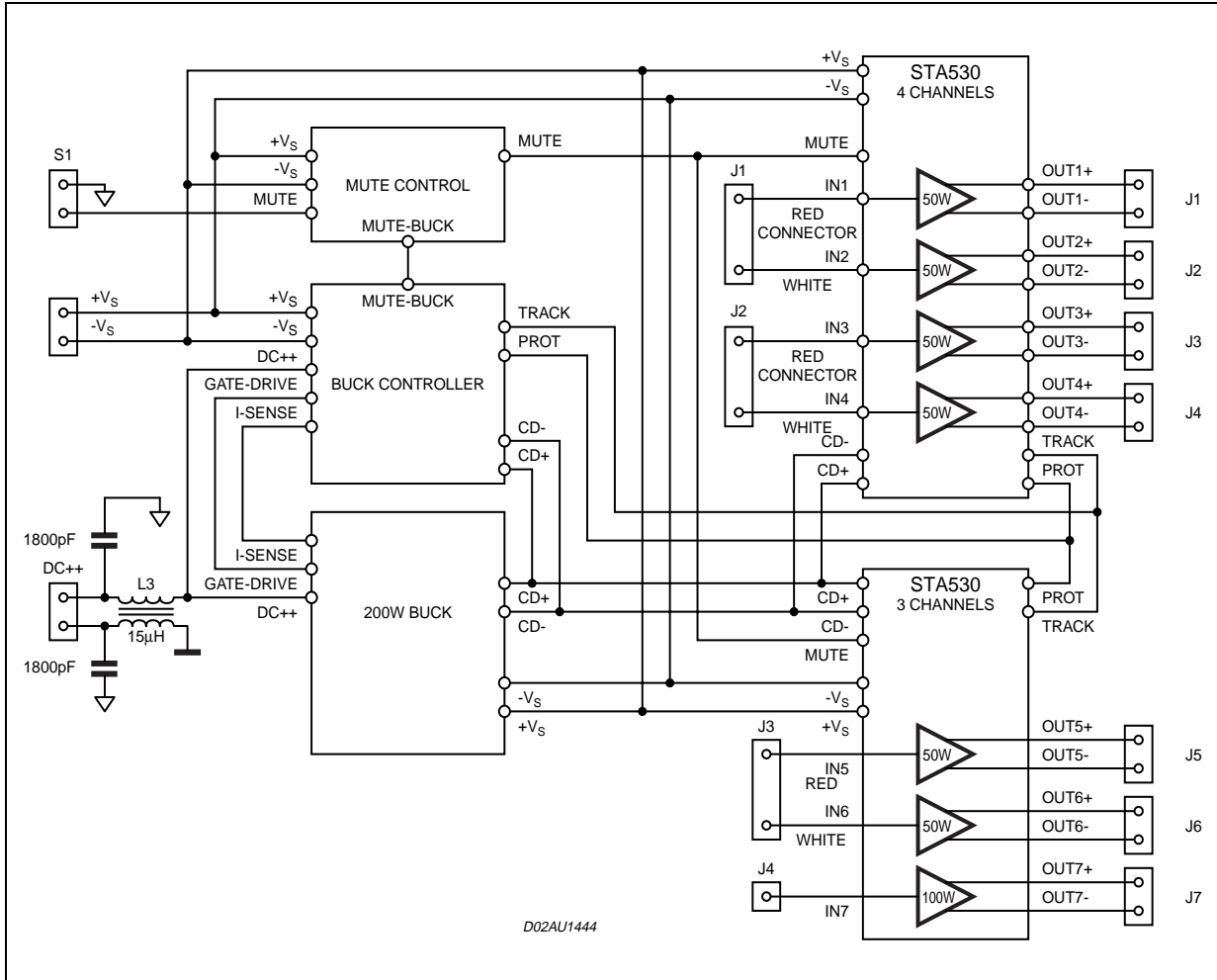

Figure 14. Application Block Diagram



DIM.	mm			inch		
	MIN.	TYP.	MAX.	MIN.	TYP.	MAX.
A	4.45	4.50	4.65	0.175	0.177	0.183
B	1.80	1.90	2.00	0.070	0.074	0.079
C		1.40			0.055	
D	0.75	0.90	1.05	0.029	0.035	0.041
E	0.37	0.39	0.42	0.014	0.015	0.016
F (1)			0.57			0.022
G	0.80	1.00	1.20	0.031	0.040	0.047
G1	25.75	26.00	26.25	1.014	1.023	1.033
H (2)	28.90	29.23	29.30	1.139	1.150	1.153
H1		17.00			0.669	
H2		12.80			0.503	
H3		0.80			0.031	
L (2)	22.07	22.47	22.87	0.869	0.884	0.904
L1	18.57	18.97	19.37	0.731	0.747	0.762
L2 (2)	15.50	15.70	15.90	0.610	0.618	0.626
L3	7.70	7.85	7.95	0.303	0.309	0.313
L4		5			0.197	
L5		3.5			0.138	
M	3.70	4.00	4.30	0.145	0.157	0.169
M1	3.60	4.00	4.40	0.142	0.157	0.173
N		2.20			0.086	
O		2			0.079	
R		1.70			0.067	
R1		0.5			0.02	
R2		0.3			0.12	
R3		1.25			0.049	
R4		0.50			0.019	
V			5° (Typ.)			
V1			3° (Typ.)			
V2			20° (Typ.)			
V3			45° (Typ.)			

(1): dam-bar protusion not included
 (2): molding protusion included

OUTLINE AND MECHANICAL DATA

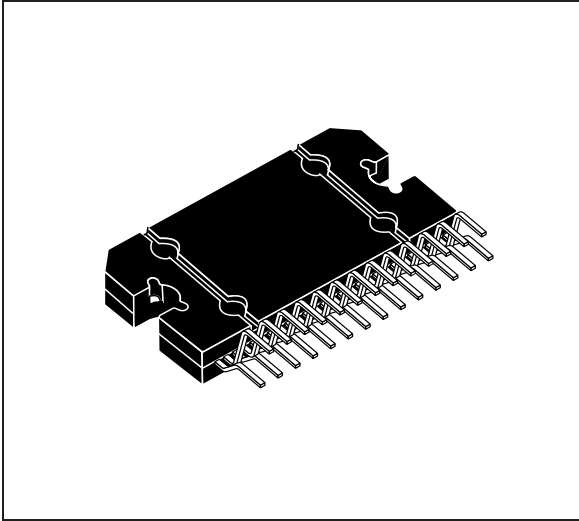

Flexiwatt27 (vertical)

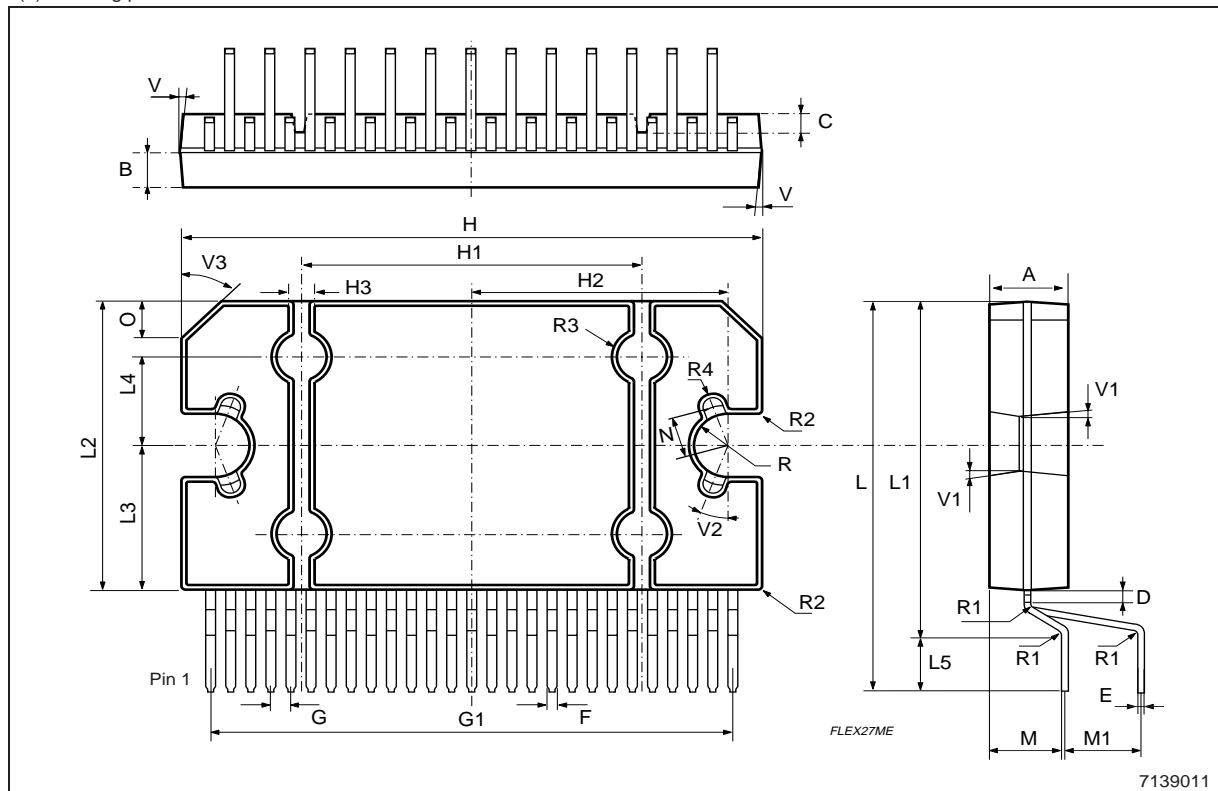

Information furnished is believed to be accurate and reliable. However, STMicroelectronics assumes no responsibility for the consequences of use of such information nor for any infringement of patents or other rights of third parties which may result from its use. No license is granted by implication or otherwise under any patent or patent rights of STMicroelectronics. Specifications mentioned in this publication are subject to change without notice. This publication supersedes and replaces all information previously supplied. STMicroelectronics products are not authorized for use as critical components in life support devices or systems without express written approval of STMicroelectronics.

The ST logo is a registered trademark of STMicroelectronics
© 2003 STMicroelectronics - All Rights Reserved

STMicroelectronics GROUP OF COMPANIES
Australia - Brazil - Canada - China - Finland - France - Germany - Hong Kong - India - Israel - Italy - Japan - Malaysia - Malta - Morocco -
Singapore - Spain - Sweden - Switzerland - United Kingdom - United States.
<http://www.st.com>