

Advanced Dual PWM and Dual Linear Power Controller

General Description

The RT9229 is a 4-in-one power controller optimized for high-performance microprocessor and computer applications. The IC integrates two PWM controllers, a linear regulator and a linear controller as well as monitoring and protection functions into a 28-pin SOP package. The first PWM controller regulates the microprocessor core voltage with a synchronous buck converter, while the second PWM controller supplies the 3.3V power with a standard buck converter. The linear regulator provides power for the clock driver circuit and the linear controller regulates power for the GTL bus.

The RT9229 features an Intel-compatible, TTL 5-bit programmable DAC that adjusts the core voltage from 2.1V to 3.5V in 0.1V increments and from 1.3V to 2.05V in 0.05V steps. The second PWM controller is user-adjustable for output level between 3.0V and 3.5V with $\pm 2.5\%$ accuracy. The 5-bit DAC has a typical $\pm 1\%$ tolerance. The linear regulator uses an internal drive device to provide 2.5V $\pm 2.5\%$ output voltage. The linear controller drives an external N-channel MOSFET or a low cost NPN bipolar transistor to provide 1.5V $\pm 2.5\%$.

The RT9229 monitors all the output voltages. A Power-good signal is issued when the core voltage is within $\pm 10\%$ of the DAC setting and the other levels are above their under-voltage levels. Additional build-in over-voltage protection for the core output uses the lower MOSFET to prevent output voltage above 115% of the DAC setting. The PWM over-current function monitors the output current using the voltage drop across the upper MOSFET's $R_{DS(ON)}$ which eliminates the need for a current sensing resistor.

Ordering Information

RT9229□□
 □ Package type
 S : SOP-28
 □ Operating temperature range
 C: Commercial standard

Features

- 4-in-one Regulated Voltages for Microprocessor Core, I/O, Clock, and GTL
- Compatible with HIP6019B
- Power-Good Output Voltage Monitor

Switching section

- 5-bit DAC Programmable from 1.3V to 3.5V
- $\pm 1\%$ DAC Accuracy
- Fast Transient Response
- Full 0% to 100% Duty Cycle Driver
- Fixed 200kHz Switching Frequency
- Adaptive Non-overlapping Gate Driver
- Over-current Monitor Uses MOSFET $R_{DS(ON)}$
- Over-voltage Protection Uses Lower MOSFET

Linear Section

- User-adjustable Linear Regulator Output Voltage
- MOSFET or NPN Driving Capability
- Ultra Fast Response Speed
- Under-voltage Protection
- Internal Thermal Shutdown

Applications

- Full Motherboard Power Regulation for Computer
- Low-voltage Distributed Power Supplies

Pin Configurations

Part Number	Pin Configurations
RT9229CS (Plastic SOP-28)	<p style="text-align: center;">TOP VIEW</p>

Absolute Maximum Ratings

- Supply Voltage +15V
- PGOOD, FAULT and GATE Voltage GND-0.3V to V_{CC}+0.3V
- Input, Output or I/O Voltage GND-0.3V to 7V
- Ambient Temperature Range 0°C to +70°C
- Junction Temperature Range 0°C to +125°C
- Storage Temperature Range -65°C to +150°C
- Lead Temperature (Soldering, 10 sec.) 300°C
- Package Thermal Resistance
SOP-28, θ_{JA} 60°C/W

Recommended Operating Conditions

- Supply Voltage +12V ±10%
- Ambient Temperature Range 0°C to 70°C
- Junction Temperature Range 0°C to 125°C

CAUTION:

Stresses beyond the ratings specified in “Absolute Maximum Ratings” may cause permanent damage to the device. This is a stress only rating and operation of the device at these or any other conditions above those indicated in the operational sections of this specification is not implied.

Electrical Characteristics

(V_{CC} = 12V, PGND = 0V, T_A = 25°C, unless otherwise specified)

Parameter	Symbol	Test Conditions	Min	Typ	Max	Units
VCC Supply Current						
Nominal Supply Current	I _{CC}	UGATE1, GATE2, GATE3, LGATE1, and VOUT4 Open	--	10	--	mA
Power-on Reset						
VCC Rising Threshold		V _{OCSET} = 4.5V	7.5	--	9.5	V
VCC Falling Threshold		V _{OCSET} = 4.5V	7	--	9	V
Rising V _{OCSET} 1 (and 2) Threshold			--	1.25	--	V
Reference and DAC						
DAC (VID0 – VID4) Input Low Voltage			--	--	0.8	V
DAC (VID0 – VID4) Input High Voltage			2.0	--	--	V
DACOUT Voltage Accuracy		DACOUT = 2.05 ~ 3.50V	-1	--	1	%
DACOUT Voltage Accuracy		DACOUT = 1.30 ~ 2.00V	-1%	--	20mV	--
Reference Voltage (Pin FB2 and FB3)	V _{REF}		1.240	1.265	1.290	V

To be continued

Parameter	Symbol	Test Conditions	Min	Typ	Max	Units
Oscillator						
Free Running Frequency			180	200	225	kHz
Ramp Amplitude	ΔV_{OSC}		--	1.9	--	V _{P-P}
Linear Regulator						
Regulation		10mA < I _{VOUT2} < 150mA	-2.5	--	2.5	%
Under-voltage Level		FB4 Rising	--	75	87	%
Under-voltage Hysteresis			--	100	--	mV
Over-current Protection	I _{OVP}		180	230	--	mA
Over-current Protection During Start-up			--	700	--	mA
Linear Controller						
Regulation		VSEN3 = GATE3 0 < I _{GATE3} < 20mA	-2.5	--	2.5	%
Under-voltage Level		FB3 Rising	--	75	87	%
Under-voltage Hysteresis			--	100	--	mV
Output Drive Current		VIN2 – VOUT3 > 1.5V	20	40	--	mA
PWM Controller Error Amplifier						
DC Gain			--	65	--	dB
PWM Controller Gate Driver						
UGATE 1 (and 2) Source	R _{UGATE}	VCC = 12V VCC - V _{UGATE} = 1V	--	3	7	Ω
UGATE 1 (and 2) Sink	R _{UGATE}	V _{UGATE} = 1V	--	3	7	Ω
LGATE Source	I _{LGATE1}	VCC = 12V, V _{LGATE1} = 2V	--	1	--	A
LGATE Sink	R _{LGATE1}	V _{LGATE1} = 1V	--	2	6	Ω
Protection						
V _{OUT1} Over-voltage Trip		VSEN1 Rising	112	115	118	%
V _{OUT2} Over-voltage Trip		VSEN2 Rising	4.1	4.3	4.5	V
FAULT Sourcing Current		V _{FAULT} = 8V	10	14	--	mA
OCSET1 (and 2) Current Source	I _{OCSET}	V _{OCSET} = 4.5V _{DC}	170	200	230	μA
Soft-start Current	I _{SS}	V _{SS} = 1V	--	11	--	μA
Power Good						
V _{OUT1} Upper Threshold		VSEN1 Rising	108	--	112	%
V _{OUT1} Under Voltage		VSEN1 Rising	90	--	94	%
V _{OUT1} Hysteresis (VSEN1/DACOUT)		Upper/Lower Threshold	--	2	--	%
PGOOD Voltage Low	V _{PGOOD}	I _{PGOOD} = -4mA	--	--	0.5	V

Function Block Diagram

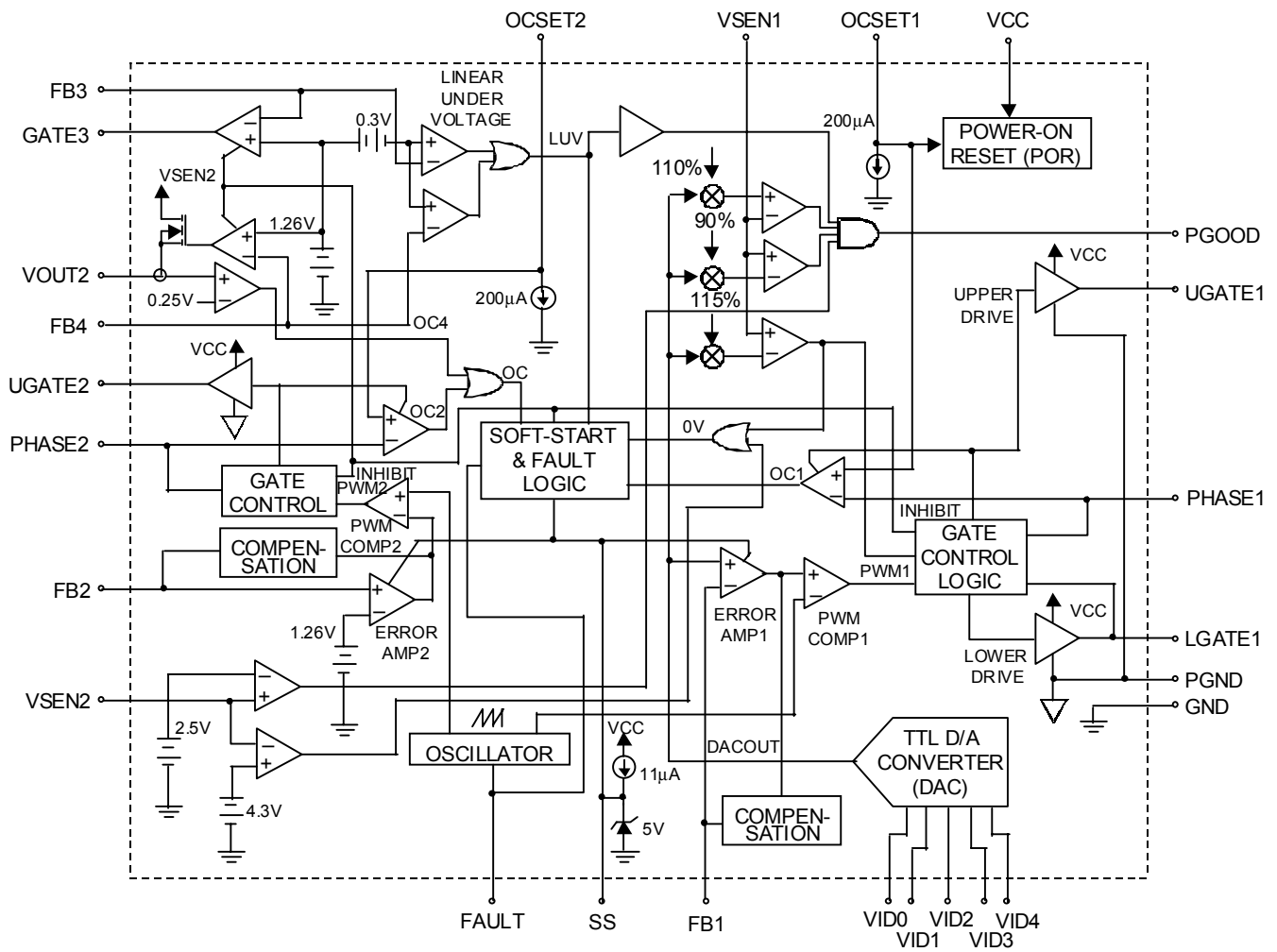

Functional Pin Description

UGATE1, UGATE2 (Pins 27 and 1)

Connect UGATE pins to the respective PWM converter's upper MOSFET gate. This pin provides the gate drive for the upper MOSFETs.

PHASE1, PHASE2 (Pins 26 and 2)

Connect the PHASE pins to the PWM converter's upper MOSFET source. These pins are used to monitor the voltage drop across the upper MOSFETs for over-current protection.

VID0, VID1, VID2, VID3, VID4 (Pin 7, 6, 5, 4, and 3)

VID0~4 are the input pins to the 5-bit DAC. The states of these five pins program the internal voltage reference, DACOUT. The level of DACOUT sets the core converter output voltage (VOUT1). It also sets the core PGOOD and OVP thresholds. Table 1 specifies the DACOUT voltage of 32 combinations of VID levels.

PGOOD (Pin 8)

PGOOD is an open collector output used to indicate the status of the PWM converter output voltage. This pin is pulled low when the core output is not within $\pm 10\%$ of the DACOUT reference voltage, or when any of the other outputs are below their under-voltage thresholds. The PGOOD output is open for '11111'VID code. See table 1.

FB1, FB2 (21 and 10)

FB1, 2 are the available external pins of the PWM error amplifiers. Both the FB pins are the inverting input of the error amplifiers.

OCSET1, OCSET2 (Pins 23 and 9)

Connect a resistor (R_{OCSET}) from this pin to the drain of the upper MOSFET. R_{OCSET} , an internal $200\mu A$ current source (I_{OCSET}), and the upper MOSFET on-resistance ($R_{DS(ON)}$) set the converter over-current (OC) trip point according to the following equation:

$$I_{PEAK} = \frac{I_{OCSET} \times R_{OCSET}}{R_{DS(ON)}}$$

An over-current trip cycles the soft-start function. Sustaining an over-current for 2 soft-start intervals shuts down the controller.

SS (Pin 12)

Connect a capacitor from this pin to ground. This capacitor, along with an internal $11\mu A$ ($V_{SS} > 1V$) current source, sets the soft-start interval of the converter.

Pulling this pin low with an open drain signal will shut down the IC.

FAULT (Pin 13)

This pin is low during normal operation, but it is pulled to about 8V ($V_{CC} = 12V$) in the event of an over-voltage or over-current condition.

FB4 (Pin 14)

Connect this pin to a resistor divider to set the linear regulator output.

VSEN1, VSEN2 (Pins 22 and 15)

These pins are connected to the PWM converters' output voltage. The PGOOD and OVP comparator circuits use these signals to report output voltage status and for over-voltage protection. VSEN2 provides the input power to the integrated linear regulator.

VOUT4 (Pin 16)

Output of the linear regulator. Supplies current up to 230mA.

GATE3 (Pin 18)

Connect this pin to the gate of an external MOSFET or the base of a NPN. This pin provides the drive for the linear controller's pass transistor.

FB3 (Pin 19)

Connect this pin to a resistor divider to set the linear controller output voltage.

PGND (Pin 24)

This is the power ground of UGATE1, LGATE1, and UGATE2. Tie the synchronous PWM converter's lower MOSFET source to this pin.

LGATE1 (Pin 25)

Connect LGATE1 to the synchronous PWM converter's lower MOSFET gate. This pin provides the gate drive for the lower MOSFET.

VCC (Pin 28)

Provide a 12V bias supply for the IC to this pin. This pin also provides the gate bias charge for all the MOSFETs controlled by the IC.

Table 1. VOUT1 Voltage Program

Pin Name					Normal OUT1 Voltage DACOUT
VID4	VID3	VID2	VID1	VID0	
0	1	1	1	1	1.30
0	1	1	1	0	1.35
0	1	1	0	1	1.40
0	1	1	0	0	1.45
0	1	0	1	1	1.50
0	1	0	1	0	1.55
0	1	0	0	1	1.60
0	1	0	0	0	1.65
0	0	1	1	1	1.70
0	0	1	1	0	1.75
0	0	1	0	1	1.80
0	0	1	0	0	1.85
0	0	0	1	1	1.90
0	0	0	1	0	1.95
0	0	0	0	1	2.00
0	0	0	0	0	2.05
1	1	1	1	1	INHIBIT
1	1	1	1	0	2.10
1	1	1	0	1	2.20
1	1	1	0	0	2.30
1	1	0	1	1	2.40
1	1	0	1	0	2.50
1	1	0	0	1	2.60
1	1	0	0	0	2.70
1	0	1	1	1	2.80
1	0	1	1	0	2.90
1	0	1	0	1	3.00
1	0	1	0	0	3.10
1	0	0	1	1	3.30
1	0	0	1	0	3.30
1	0	0	0	1	3.40
1	0	0	0	0	3.50

Typical Application Circuit

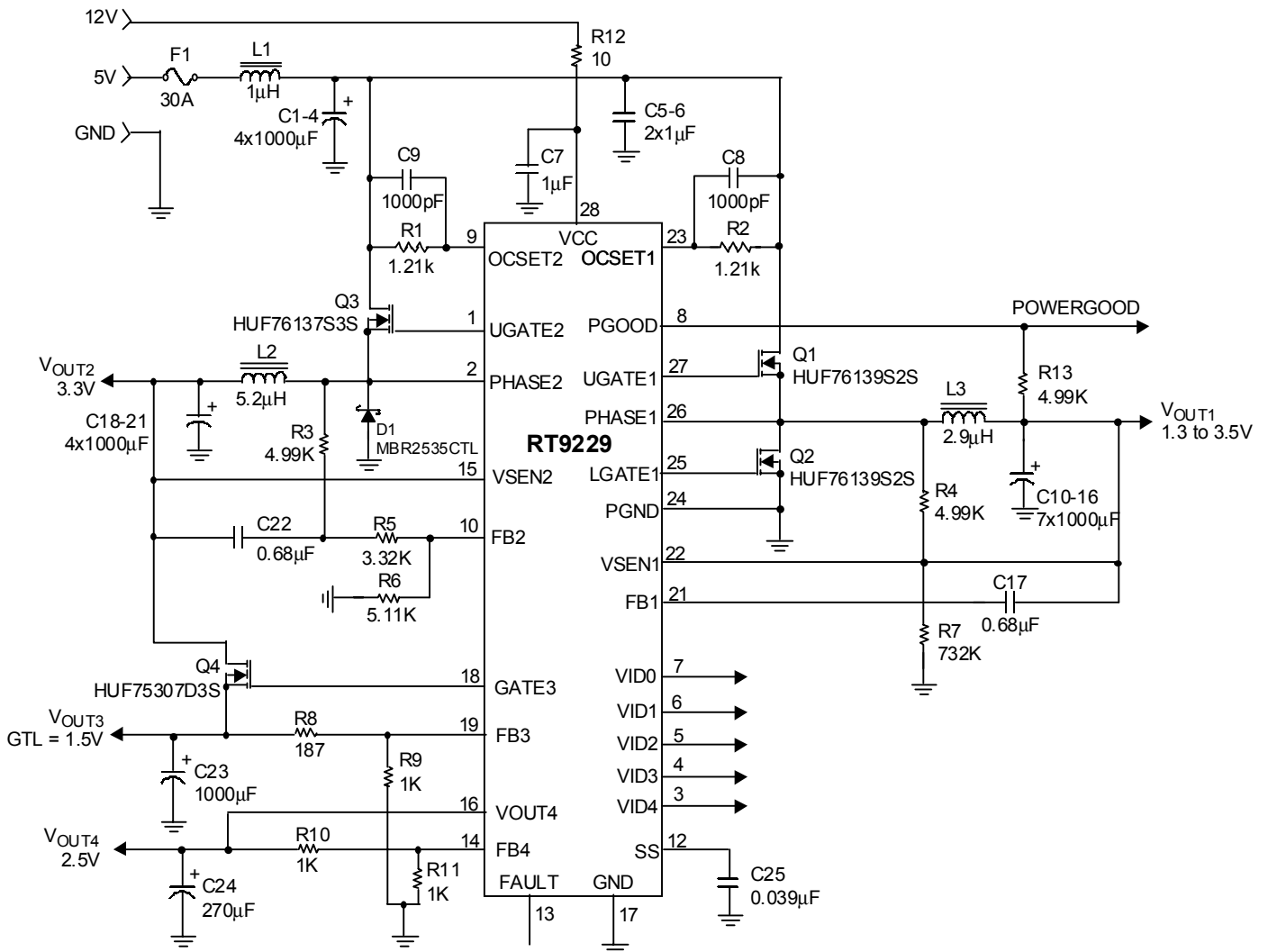

Package Information

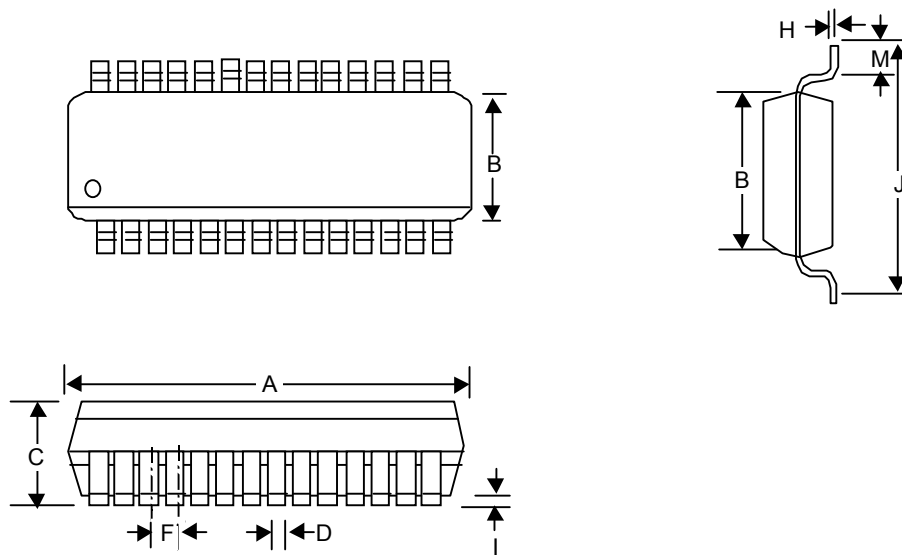

Symbol	Dimensions In Millimeters		Dimensions In Inches	
	Min	Max	Min	Max
A	17.704	18.110	0.697	0.713
B	7.391	7.595	0.291	0.299
C	2.362	2.642	0.093	0.104
D	0.330	0.508	0.013	0.020
F	1.194	1.346	0.047	0.053
H	0.229	0.330	0.009	0.013
I	0.102	0.305	0.004	0.012
J	10.008	10.643	0.394	0.419
M	0.381	1.270	0.015	0.050

RICHTEK TECHNOLOGY CORP.

Headquarter

6F, No. 35, Hsintai Road, Chupei City

Hsinchu, Taiwan, R.O.C.

Tel: (8863)5510047 Fax: (8863)5537749

RICHTEK TECHNOLOGY CORP.

Taipei Office (Marketing)

8F-1, No. 137, Lane 235, Paochiao Road, Hsintien City

Taipei County, Taiwan, R.O.C.

Tel: (8862)89191466 Fax: (8862)89191465

Email: marketing@richtek-ic.com.tw