

AN6873N, AN6873NS

Fluorescent Display Tube Drive Circuit (8-circuit)

Overview

The AN6873N and AN6873NS are ICs designed for driving the high-breakdown fluorescent display tubes.

Features

- Built-in 8-circuit
- Capable of directly driving the fluorescent tubes because of built-in pull-down resistors
- CMOS or TTL input directly drivable

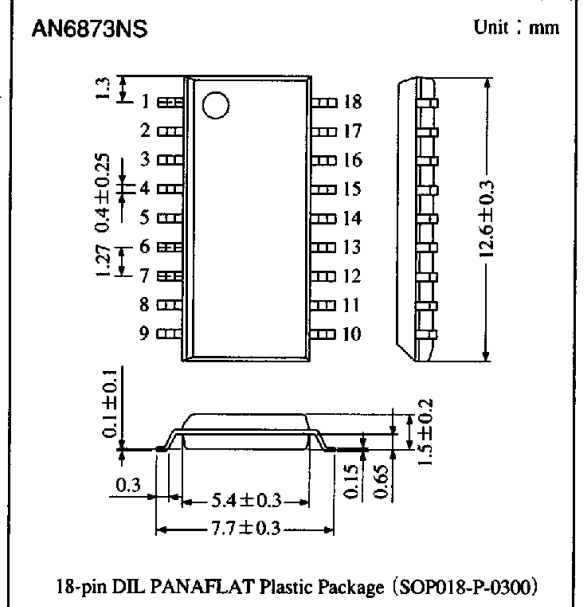
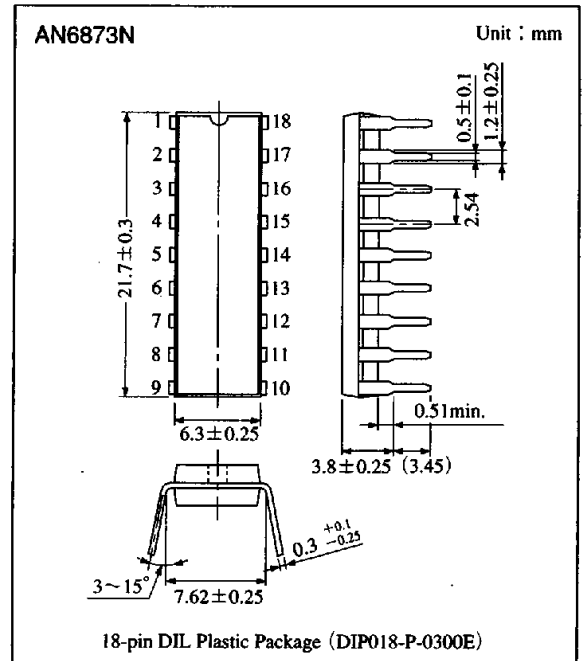

Block Diagram

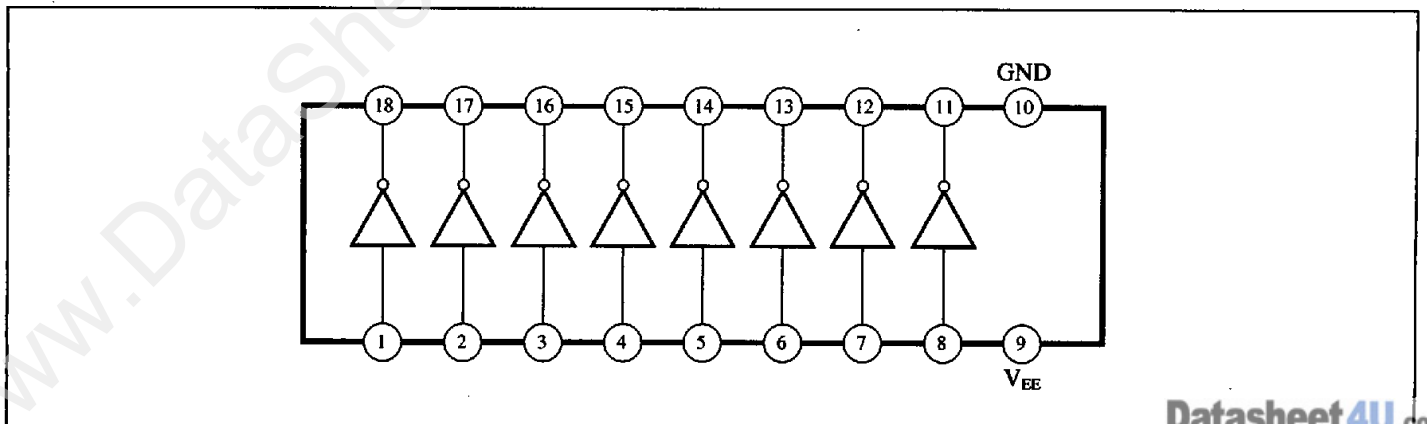

Pin Descriptions

Pin No.	Pin name	Pin No.	Pin name
1	Ch.1 input	10	Earth
2	Ch.2 input	11	Ch.8 output
3	Ch.3 input	12	Ch.7 output
4	Ch.4 input	13	Ch.6 output
5	Ch.5 input	14	Ch.5 output
6	Ch.6 input	15	Ch.4 output
7	Ch.7 input	16	Ch.3 output
8	Ch.8 input	17	Ch.2 output
9	Negative supply voltage	18	Ch.1 output

Absolute Maximum Ratings (Ta=25°C)

Parameter		Symbol	Rating	Unit
Supply voltage		V_{EE}	-55	V
Supply current		I_{CC}	-45	mA
Power dissipation	AN6873N	P_D	500	mW
	AN6873NS		420	
Storage temperature		T_{opr}	-30 to +75	°C
Operating ambient temperature	AN6873N	T_{stg}	-55 to +150	°C
	AN6873NS		-55 to +125	

Recommended Operating Range (Ta=25°C)

Parameter	Symbol	Range
Operating supply voltage range	V_{EE}	-50 to -15V

Electrical Characteristics (Ta=25°C)

Parameter	Symbol	Condition	min	typ	max	Unit
Input voltage high level	V_{IH}	$V_{EE} = -50V, V_O \leq -45V$	-1.5	—	—	V
Input voltage low level	V_{IL}	$V_{EE} = -50V, V_O \geq -3V$	—	—	-4	V
Input current high level	I_{IH}	$V_{EE} = -50V, V_I = -1.5V$	-280	-70	—	μA
Input current low level (1)	I_{IL1}	$V_{EE} = -50V, V_I = -4V$	-1.2	-0.25	—	mA
Input current low level (2)	I_{IL2}	$V_{EE} = -50V, V_I = -7V$	-2.6	-0.6	—	mA
Output voltage high level	V_{OH}	$V_{EE} = -50V, V_I = -4V, I_O = -40mA$	-3	-1.5	—	V
Output voltage low level	V_{OL}	$V_{EE} = -50V, V_I = -1.5V, I_O = 0mA$	—	-49.9	-45	V
Supply current (1)	$I_{CC(OFF)}$	$V_{EE} = -50V, V_I = -1.5V$	—	—	1.3	mA
Supply current (2)	$I_{CC(ON)}$	$V_{EE} = -50V, V_I = -4V$	—	—	12	mA

■ Characteristics Curve

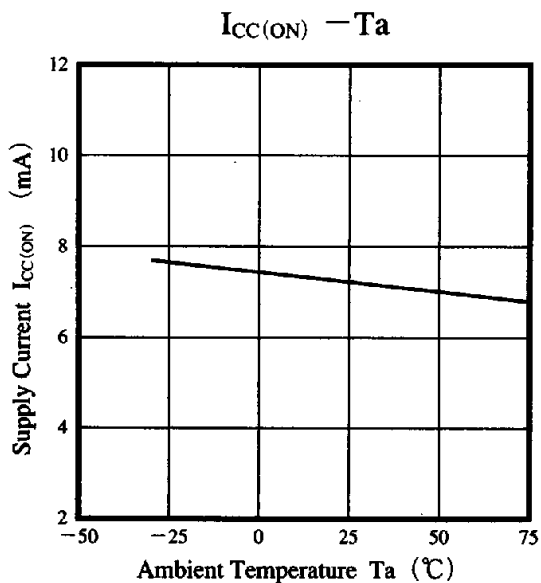
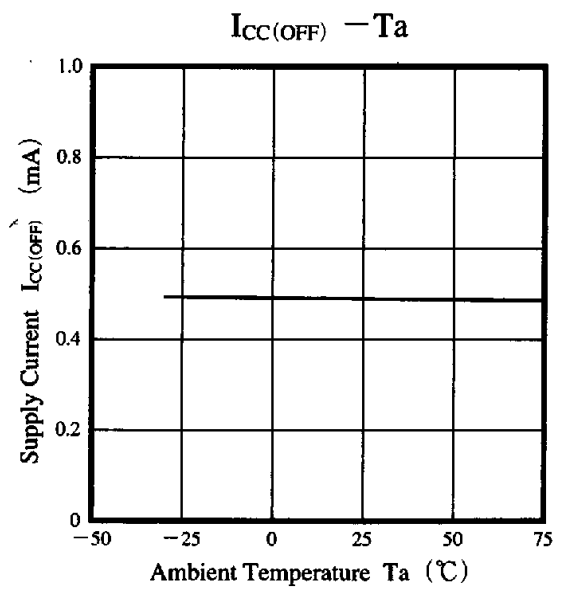
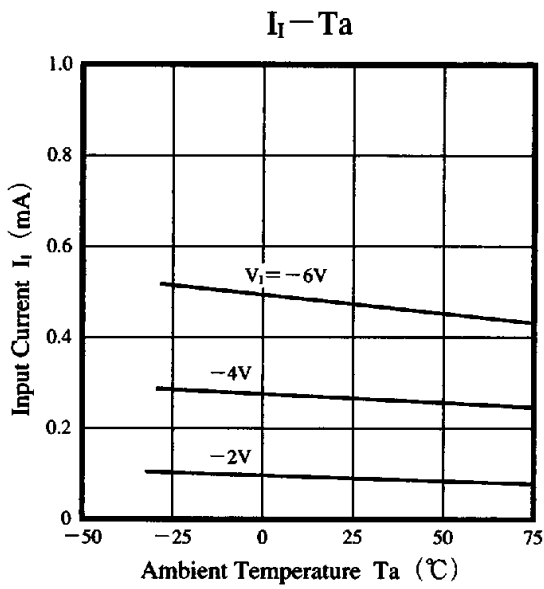
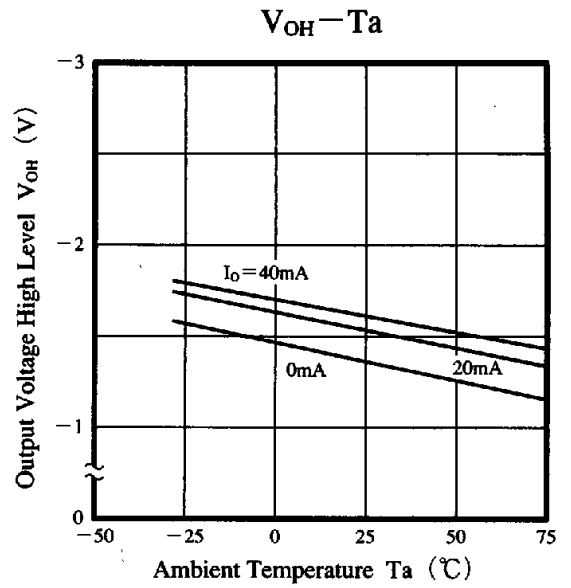
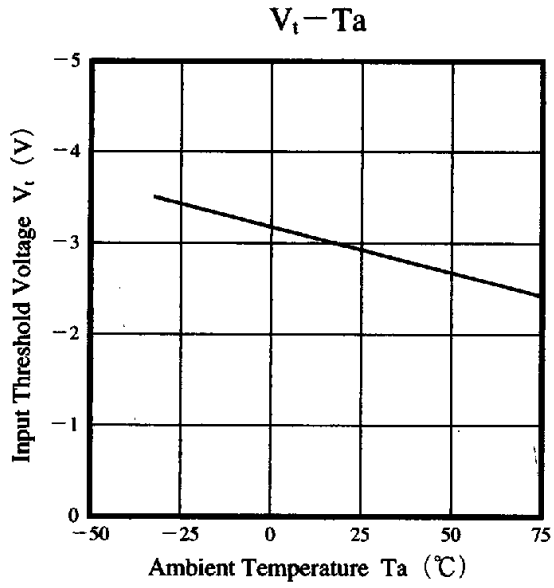

■ Equivalent Circuit (1/8 Circuit)

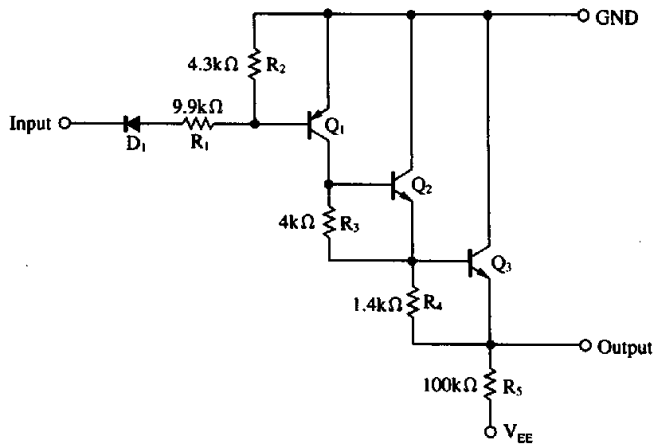

■ Application Circuit

