

CTS 212 Rotary Switch

- Hill and valley detent
- Balanced double bump detent spring
- Excellent feel
- 30°, 60° or 90° indexing
- Spring return styles available
- Adjustable stop available
- Solder lug and printed circuit terminals available
- Molded stator prevents solder from flowing into the circuit
- Custom switching patterns available
- Index or wafers are available separately

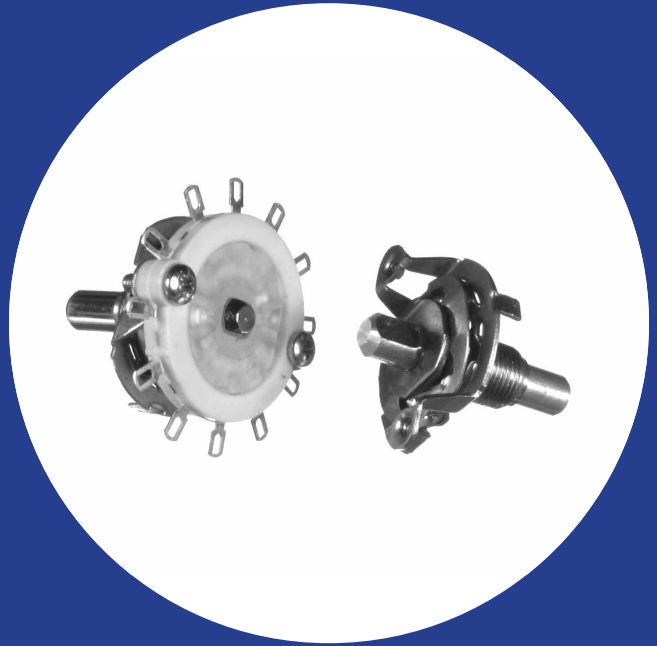

Electrical and Mechanical Specifications

Indexing

Double bump spring hill and valley detent with
30° indexing for 2 through 12 positions or
60° indexing from 2 to 6 positions.
90° indexing -consult CTS

Voltage and Current Rating

UL Rating: $\frac{3}{4}$ amp at 125 VAC (shorting type only)
Special Rating: $\frac{1}{4}$ amp at 28 VDC (shorting or
non shorting)
1 amp at 28 VDC Shorting

Contact Resistance

0.008 to 0.010 ohm when measured from adjacent
terminals

Stop Strength

15" lbs (17.3Kg-cm).

Torque

Up to 48" oz. (3.5Kg-cm).

Detent Rotational Life

Standard: 25,000 cycles through 12 positions and
return at 10 cycles per minute.

Materials

Shaft: Aluminum or unplated brass at CTS option
Bushing: Standard — Brass

Materials (continued)

Detent Spring: Spring brass or nickel silver depending
on torque requirements

Front Plate: Zinc plated or nickel steel at CTS option
Rotor Contacts, Stator Contacts and Terminals: Silver
plated brass standard

Stator Insulator: Glass reinforced thermoset material

Bushing Lengths

Standard: $\frac{3}{8}$ "-32 UNEF-2A Thread, $\frac{1}{4}$ " (6.35mm)
or $\frac{3}{8}$ " (9.53mm) long.

Special Lengths: Available as required — Brass

Locating Lugs

Standard: Left side .531" (13.5mm) radius

Special: Right side .531" (13.5mm) radius or no lug

Shaft Trim

Standard: Plain round

Special: Flat, slot, knurl, or mixed (flat with slot)

Frames

Machine screw, bolt & nut, or rivet construction

Lubrication

Special lubrication is used sufficient for the life
of the index assembly under normal hand operation.

Physical Dimensions

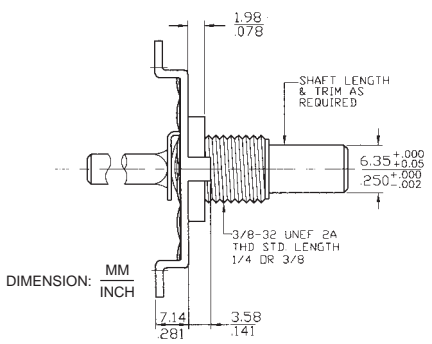

Detent Only

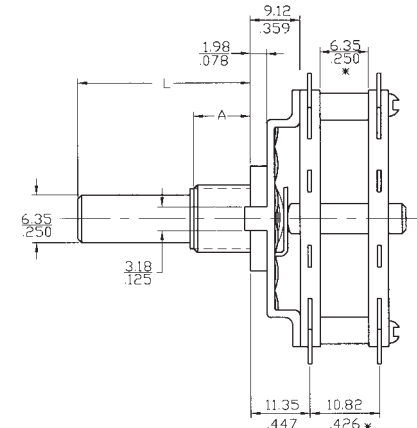
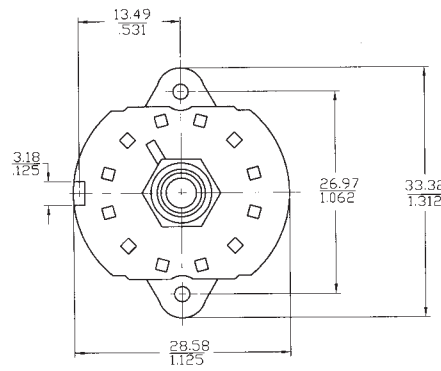

Typical Assembled Switch

Available Terminal Styles

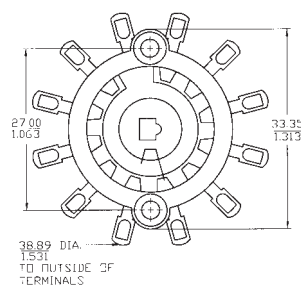

T-Style

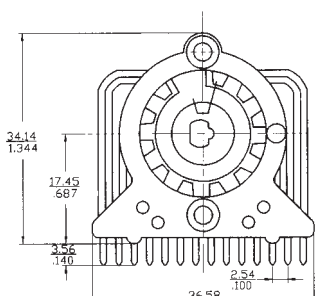

P-Style

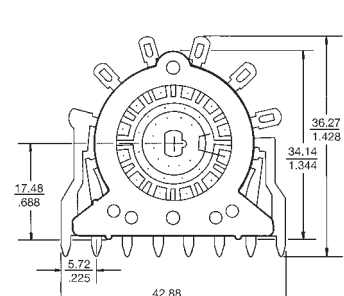

X-Style

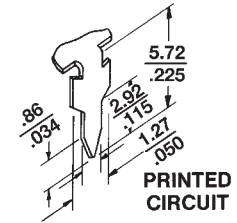
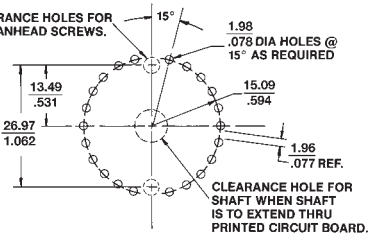

U-Style

Ordering Information

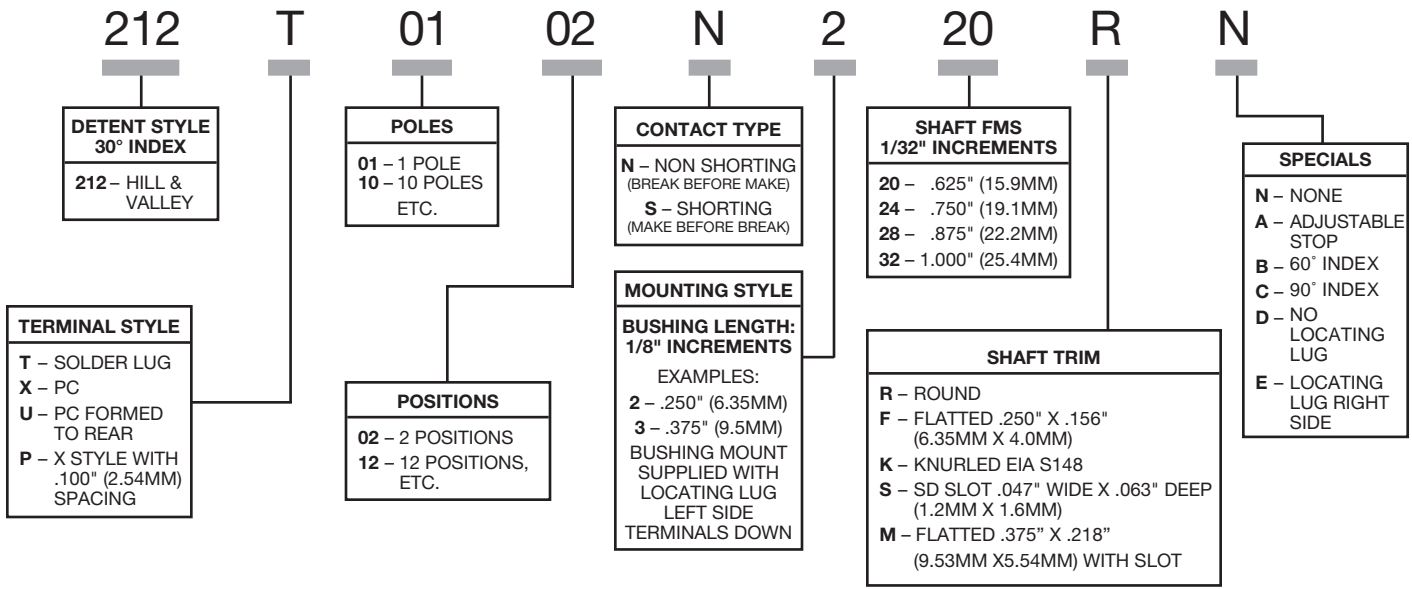

Order From:

CTS CORPORATION, ELECTROCOMPONENTS / 1601 Mishawaka Street / Elkhart, Indiana 46514
North America Toll Free (888) 287-4690 / (219) 296-6700 / FAX: (219) 293-1240 <http://www.ctscorp.com>

CTS COMPONENTS TAIWAN, LTD. / 7, Central 6th Road (Chung Liu Road) / P.O. Box 26-20
Kaohsiung Export Processing Zone / Kaohsiung, Taiwan, Rep. of China
(07) 8216145 / FAX: (07) 8417642.8110040