

FEATURES

- **LOW POWER DISSIPATION**
V_{CC} = 3 V, I_{CC} = 7 mA
- **HIGH CONVERSION GAIN**
80 dB
- **ON CHIP OSCILLATOR OR LO BUFFER:**
DC - 450 MHz
- **OUTPUT LIMITING**
450 mVp-p
- **BROADBAND OPERATION**
DC - 450 MHz
- **POWER SAVE FUNCTION**
I_{CC} (ps) = <100 μA

DESCRIPTION

The UPC2768GR is a frequency converter manufactured with the NESAT III process. This product consists of an RF input amplifier, Gilbert cell mixer, Local Oscillator or LO buffer, IF amplifier, external filter port, and IF output limiting amplifier. The on-chip local oscillator only requires an external tank circuit. The power save feature enables users to minimize overall current consumption when dormant. This device was specifically designed for low-cost second IF receivers, key-less entry applications, security systems, GPS, and other low power Part 15 mobile radios.

INTERNAL BLOCK DIAGRAM

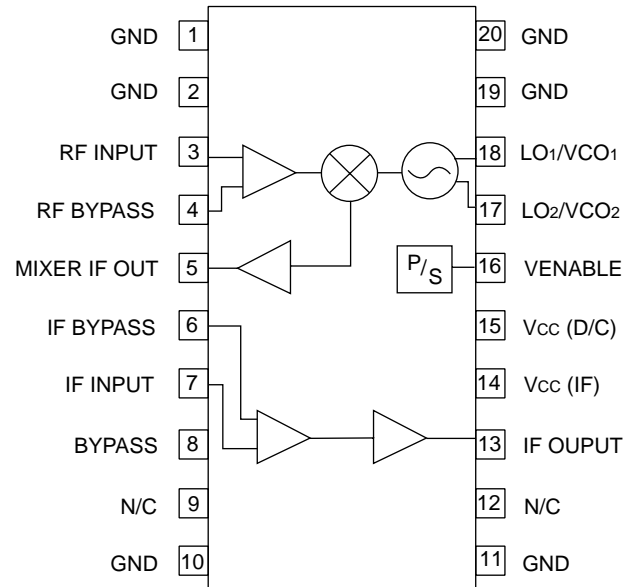

ELECTRICAL CHARACTERISTICS (V_{CC} = 3.0 V, T_A = 25°C, Z_L = Z_S = 50 Ω, VENABLE ⊕ 2.5 V unless otherwise specified)

PART NUMBER PACKAGE OUTLINE			UPC2768GR S20 (SSOP 20)			
SYMBOLS	PARAMETERS AND CONDITIONS	UNITS	MIN	TYP	MAX	
I _{CC}	Circuit Current (V _{ENABLE} ≥ 2.5 V) ⁴ (V _{ENABLE} ≤ 0.5 V)	mA μA		7	100	
f _{RF} , f _{LO}	RF and LO Input Frequency Range (3 dB BW) ¹ , f _{IF} = 10 MHz	MHz	DC		450	
CG	Conversion Gain ² , f _{RF} = 433 MHz, f _{IF} = 25 MHz	dB	33	36	40	
NF	Noise Figure ² , f _{RF} = 450 MHz, f _{IF} = 10 MHz	dB		12		
Leak LO-RF	LO to RF Leakage ³ , f _{LO} = 1 to 450 MHz	dBm		-62		
Leak LO-IF	LO to IF Leakage ³ , f _{LO} = 1 to 450 MHz	dBm		-25		
IF Amplifier	G _S	IF Amplifier Small Signal Gain f _{IF} = 10.7 MHz f _{IF} = 25.0 MHz	dB dB	40 38	44 42	47 45
	V _{OUT}	Limiting Output Voltage, Z _L = 2KΩ, f _{IF} = 10 MHz	mVp-p		450	
	PSAT	Saturated Output Power	dBm		-20	

Notes:

1. Max freq. range is -3 dB from conversion gain for R_F = 50 MHz
2. Down converter only (RF_{IN} to mixer IF_{OUT}).
3. P_{LO} = -10 dBm external, or using internal LO.
4. Down converter and IF amp may be operated separately. Typical I_{CC} for down converter is 5.5 mA (pin 15). Typical I_{CC} for IF amp is 1.4 mA (pin 14).

ABSOLUTE MAXIMUM RATINGS¹ (T_A = 25°C)

SYMBOLS	PARAMETERS	UNITS	RATINGS
V _{CC}	Supply Voltage	V	5
P _T	Power Dissipation ²	mW	433
T _{OP}	Operating Temperature	°C	-40 to +85
T _{STG}	Storage Temperature	°C	-55 to +150

Note:

1. Operation in excess of any one of these parameters may result in permanent damage.
2. Mounted on a 50x50x1.6 mm epoxy glass PWB (T_A = 85°C).

RECOMMENDED OPERATING CONDITIONS

SYMBOLS	PARAMETERS	UNITS	MIN	TYP	MAX
V _{CC}	Supply Voltage	V	2.7	3.0	3.3
T _{OP}	Operating Temperature	°C	-40	25	85
f _{IF}	IF Frequency Range	MHz	DC		25

TYPICAL PERFORMANCE CURVES (T_A = 25°C, V_{CC} = 3.0 V, V_{ENABLE} ≥ 2.5 V unless otherwise specified)

CIRCUIT CURRENT vs. SUPPLY VOLTAGE AND ENABLE VOLTAGE

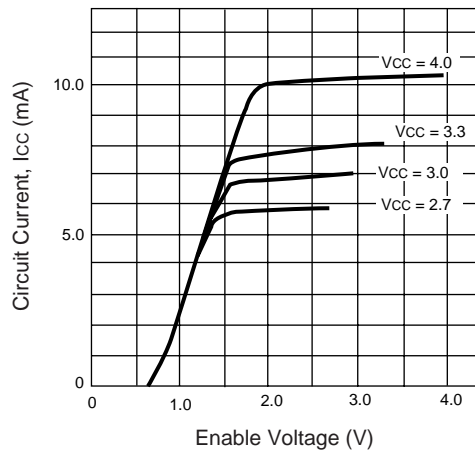

CIRCUIT CURRENT vs. SUPPLY VOLTAGE AND ENABLE VOLTAGE (T_A = 85°C)

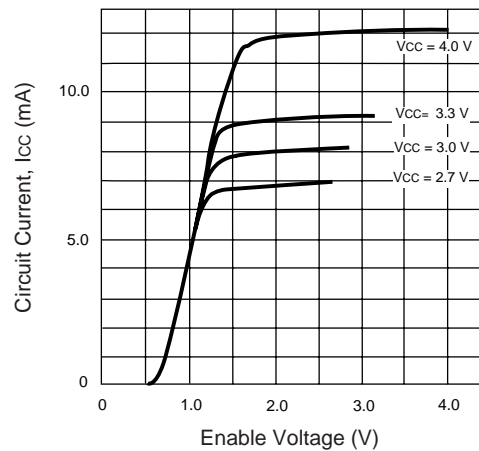

CIRCUIT CURRENT vs. SUPPLY VOLTAGE AND ENABLE VOLTAGE (T_A = 40°C)

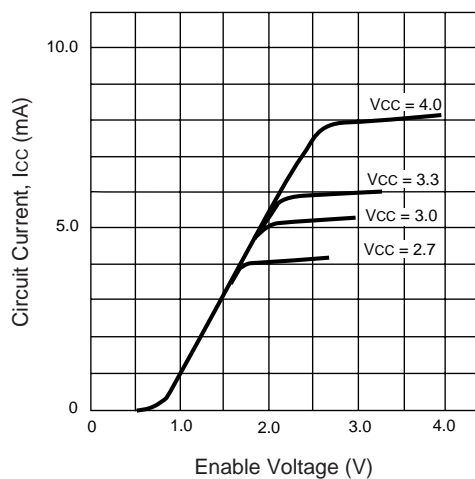

CONVERSION GAIN vs. RF FREQUENCY AND TEMPERATURE (DOWN CONVERTER ONLY)

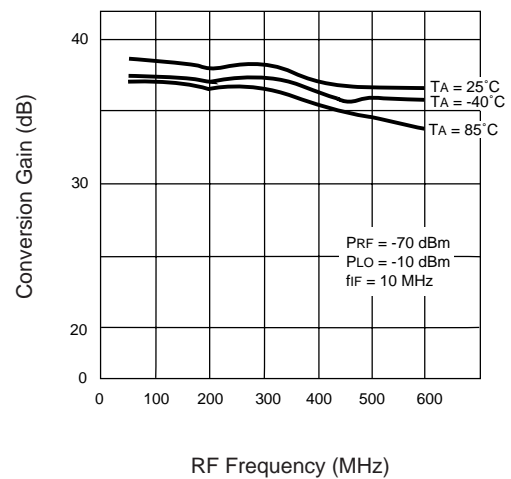

TYPICAL PERFORMANCE CURVES ($T_A = 25^\circ\text{C}$, $V_{CC} = 3.0\text{ V}$, $V_{ENABLE} \geq 2.5\text{ V}$ unless otherwise specified)

CONVERSION GAIN VS. IF FREQUENCY (DOWNCONVERTER ONLY)

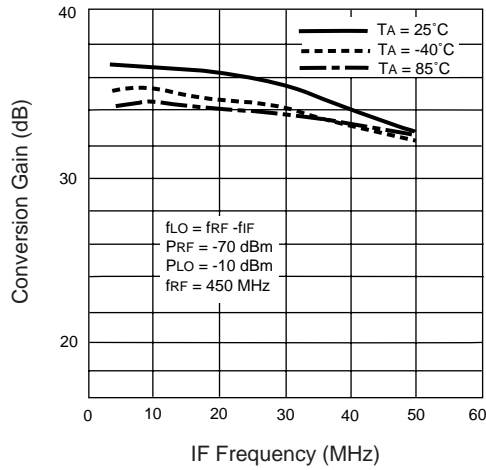

OUTPUT VOLTAGE vs. INPUT POWER

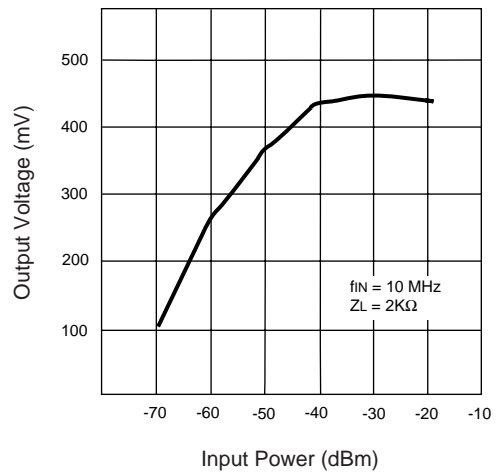

LO LEAKAGE vs. FREQUENCY

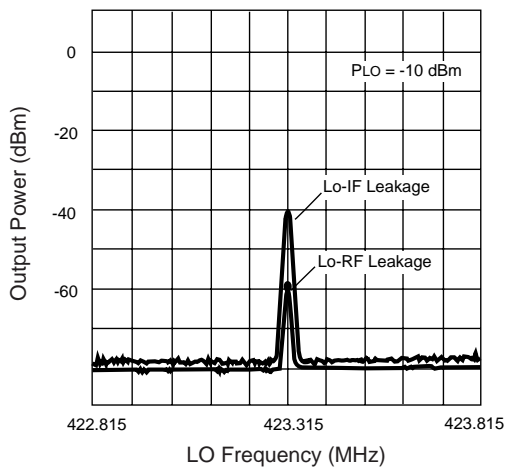

RF INPUT MATCH (S11)

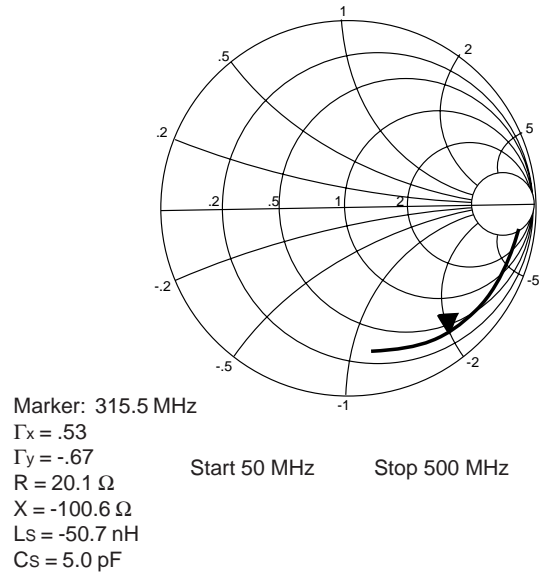

TYPICAL DETECTOR CIRCUIT

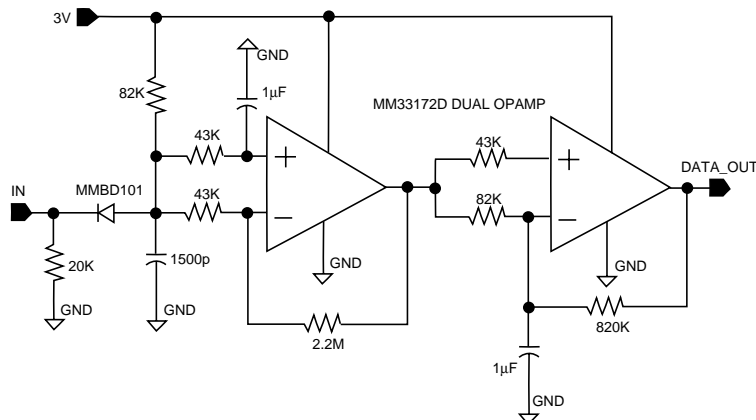

APPLICATION CIRCUIT

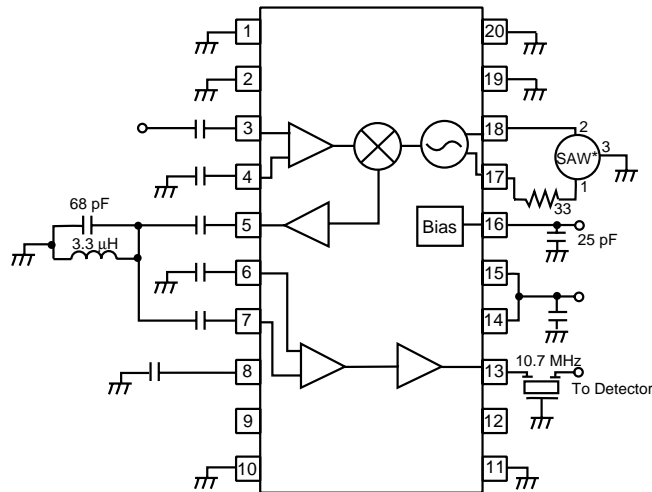

- 1. GND
- 2. GND
- 3. RF Input
- 4. RF Bypass
- 5. Mixer IF
- 6. IF Bypass
- 7. IF Input
- 8. Bypass
- 9. N/C
- 10. GND
- 11. GND
- 12. N/C
- 13. IF OUTPUT
- 14. Vcc (IF)
- 15. Vcc (D/C)
- 16. VENABLE
- 17. Lo2/VCO2
- 18. Lo1/VCO1
- 19. GND
- 20. GND

* Recommended devices:
 RF Monolithics RO2125A for 304 MHz
 RF Monolithics RO2102A for 423 MHz
 or equivalent

All unmarked caps are 1000 pF

OUTLINE DIMENSIONS (Units in mm)

PACKAGE OUTLINE SSOP 20

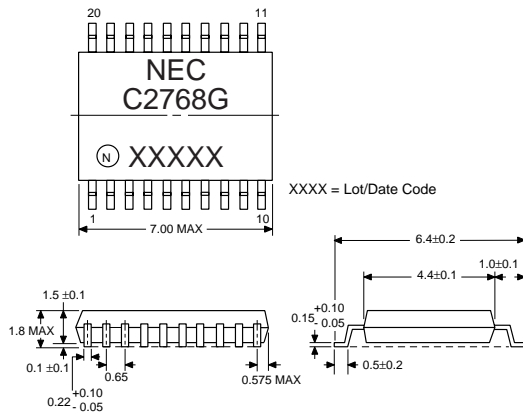

Lead Material: Alloy 42
 Lead Plating: Lead Tin Alloy

LEAD CONNECTIONS:

- 1. GND
- 2. GND
- 3. RF INPUT
- 4. RF BYPASS
- 5. MIXER IF
- 6. IF BYPASS
- 7. IF INPUT
- 8. BYPASS
- 9. N/C
- 10. GND
- 11. GND
- 12. N/C
- 13. IF OUTPUT
- 14. Vcc (IF)
- 15. Vcc (D/C)
- 16. V ENABLE
- 17. Lo2/VCO2
- 18. Lo1/VCO1
- 19. GND
- 20. GND

TYPICAL INPUT MATCHING CIRCUIT

3 pole high-pass network provides greater than 20 dB rejection in the FM band (<100 MHz) and a VSWR of 1.5:1 at 315 MHz.

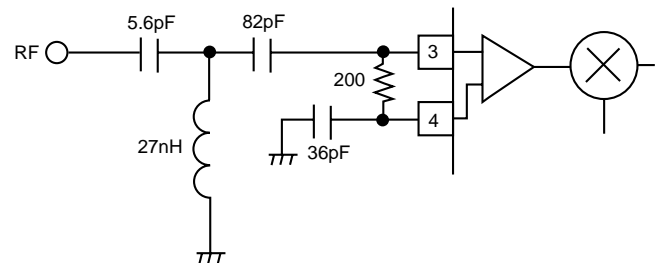

ORDERING INFORMATION

PART NUMBER	QUANTITY
UPC2768GR-E1	2500/Reel

EXCLUSIVE NORTH AMERICAN AGENT FOR **NEC** RF, MICROWAVE & OPTOELECTRONIC SEMICONDUCTORS

CEL CALIFORNIA EASTERN LABORATORIES • Headquarters • 4590 Patrick Henry Drive • Santa Clara, CA 95054-1817 • (408) 988-3500 • Telex 34-6393 • FAX (408) 988-0279
 24-Hour Fax-On-Demand: 800-390-3232 (U.S. and Canada only) • Internet: <http://WWW.CEL.COM>

DATA SUBJECT TO CHANGE WITHOUT NOTICE

PRINTED IN USA ON RECYCLED PAPER