

## **UDN-2935Z AND UDN-2950Z BIPOLAR HALF-BRIDGE MOTOR DRIVERS**

### **FEATURES**

- 3.5 A Peak Output
- 37 V Min. Output Breakdown
- Output Transient Protection
- Tri-State Outputs
- TTL, CMOS, PMOS, NMOS Compatible Inputs
- Internal Thermal Shutdown
- High-Speed Chopper (to 100 kHz)
- UDN-2935Z Replaces SG3635P
- UDN-2950Z Replaces UDN-2949Z, SN75605
- TO-220 Style Packages

**B**OTH Type UDN-2935Z and UDN-2950Z integrated circuits are designed for servo-motor applications using pulse-width modulation. These two high-current, monolithic half-bridge motor drivers combine a sink-and-source driver with diode transient protection, input gain, level shifting, logic stages, and a voltage regulator for single-supply operation.

The UDN-2935Z output goes high with an active low input at pin 2; it is especially desirable in NMOS microprocessor applications. The UDN-2950Z output goes high with an active high input at pin 2; its inputs can be tied together for single-wire control. The input circuitry of both devices is compatible with TTL and low-voltage CMOS, PMOS, and NMOS logic. Both ICs have logic lockout (tri-state output) that prevents source and sink drivers from turning ON simultaneously.

In typical applications, the chopper-drive mode is characterized by low power-dissipation levels, low saturation voltages, and short chopper-storage

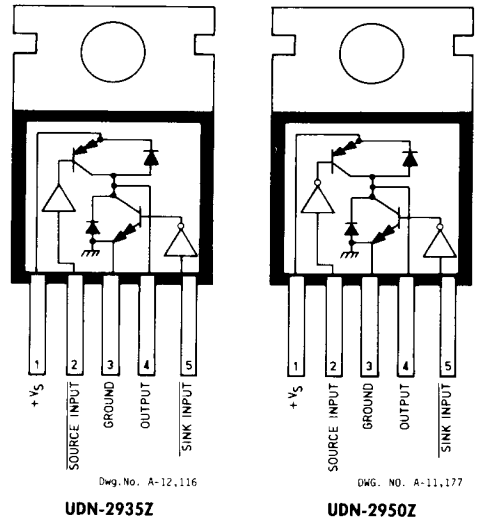

times for the sink drivers. The motor drivers can be used in pairs for full-bridge operation, or as triplets in three-phase brushless d-c motor-drive applications. They can also be teamed with the Sprague Electric UCN-4202A stepper motor translator/driver for bipolar d-c stepper motor control

The motor drivers' single-chip construction and power-tab TO-220 package enable cost-effective and reliable system designs supported by excellent power-dissipation ratings, minimum size, and ease of installation; because the package's heat tab is at ground potential, several devices can share a common heat sink without insulating hardware.

**ABSOLUTE MAXIMUM RATINGS**

Supply Voltage Range,  $V_S$  ..... 8.0 V to 35 V  
 Output Voltage Range,  $V_{OUT}$  ..... -2.0 V to  $V_S + 2.0$  V  
 Input Voltage Range,  $V_{IN}$  ..... -0.3 V to +7.0 V  
 Peak Output Current (100 ms, 10% d-c),  $I_{OP}$  .....  $\pm 3.5$  A  
 Continuous Output Current,  $I_{OUT}$  .....  $\pm 2.0$  A  
 Package Power Dissipation,  $P_D$  ..... See Graph  
 Operating Temperature Range,  $T_A$  ..... -20°C to +85°C  
 Storage Temperature Range,  $T_S$  ..... -55°C to +85°C

**ALLOWABLE POWER DISSIPATION  
AS A FUNCTION OF AMBIENT TEMPERATURE**

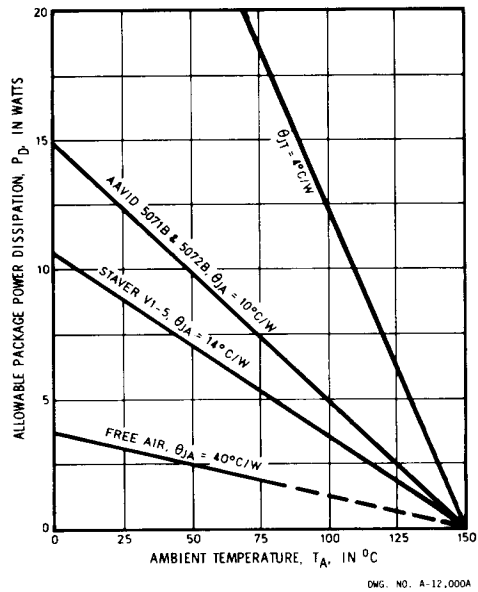

**TRUTH TABLE**

| Source Driver,<br>Pin 2 | Sink Driver,<br>Pin 5 | Output, Pin 4 |           |
|-------------------------|-----------------------|---------------|-----------|
|                         |                       | UDN-2935Z     | UDN-2950Z |
| Low                     | Low                   | High          | Low       |
| Low                     | High                  | High          | High Z    |
| High                    | Low                   | Low           | High      |
| High                    | High                  | High Z        | High      |

## FUNCTIONAL BLOCK DIAGRAMS

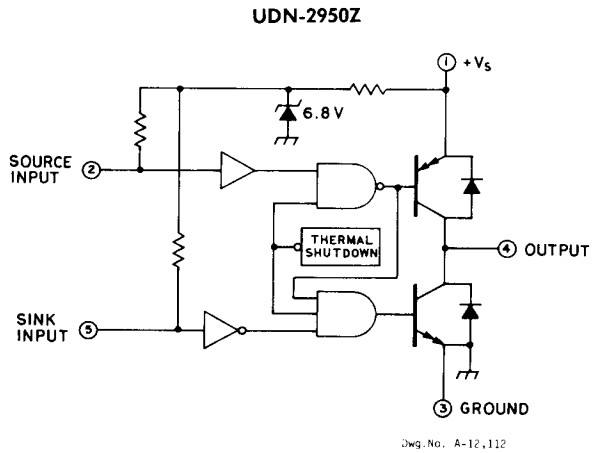
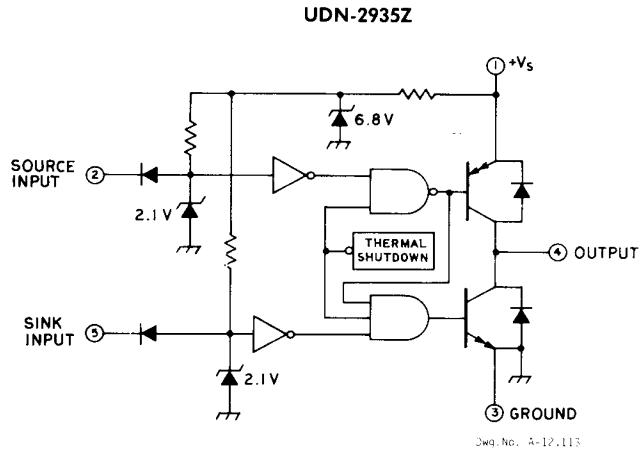

**ELECTRICAL CHARACTERISTICS at  $T_A = +25^\circ\text{C}$ ,  $T_{TAB} = +70^\circ\text{C}$ ,  $V_S = 35\text{ V}$  (unless otherwise noted)**

| Characteristic              | Source Driver Input, Pin 2 |                    | Sink Driver Input, Pin 5 | Output, Pin 4 | Other  | Limits |      | Units         |
|-----------------------------|----------------------------|--------------------|--------------------------|---------------|--------|--------|------|---------------|
|                             | UDN-2935Z                  | UDN-2950Z          |                          |               |        | Min.   | Max. |               |
| Output Leakage Current      | 2.4 V                      | 0.8 V              | 2.4 V                    | 0 V           | —      | —      | -500 | $\mu\text{A}$ |
|                             | 2.4 V                      | 0.8 V              | 2.4 V                    | 35 V          | —      | —      | 500  | $\mu\text{A}$ |
| Output Sustaining Voltage   | 2.4 V                      | 0.8 V              | 0.8 to 2.4 V             | 2.0 A         | Fig. 1 | 35     | —    | V             |
| Output Saturation Voltage   | 0.8 V                      | 2.4 V              | 2.4 V                    | -2.0 A        | —      | 33     | —    | V             |
|                             | 2.4 V                      | 0.8 V              | 0.8 V                    | 2.0 A         | —      | —      | 2.0  | V             |
| Output Source Current       | 0.8 V                      | 2.4 V              | 2.4 V                    | —             | —      | -2.0   | —    | A             |
| Output Sink Current         | 2.4 V                      | 0.8 V              | 0.8 V                    | —             | —      | 2.0    | —    | A             |
| Input Open-Circuit Voltage  | -250 $\mu\text{A}$         | -250 $\mu\text{A}$ | -250 $\mu\text{A}$       | —             | —      | —      | 7.5  | V             |
| Input Current               | —                          | 2.4 V              | 2.4 V                    | NC            | —      | —      | -700 | $\mu\text{A}$ |
|                             | 2.4 V                      | —                  | 2.4 V                    | NC            | —      | —      | 10   | $\mu\text{A}$ |
|                             | 0.8 V                      | 0.8 V              | 0.8 V                    | NC            | —      | —      | -1.6 | mA            |
| Propagation Delay           | 2.4 V                      | 0.8 V              | 0.8 to 2.4 V             | 2.0 A         | —      | —      | 750  | ns            |
|                             | 0.8 to 2.4 V               | 2.4 to 0.8 V       | 2.4 V                    | 2.0 A         | —      | —      | 2.0  | $\mu\text{s}$ |
| Clamp Diode Forward Voltage | NC                         | NC                 | NC                       | 2.0 A         | Fig. 2 | —      | 2.2  | V             |
| Supply Current              | 0.8 V                      | 2.4 V              | NC                       | NC            | —      | —      | 35   | mA            |

NOTE: Positive (negative) current is defined as going into (coming out of) the specified device pin.

TEST FIGURE 1

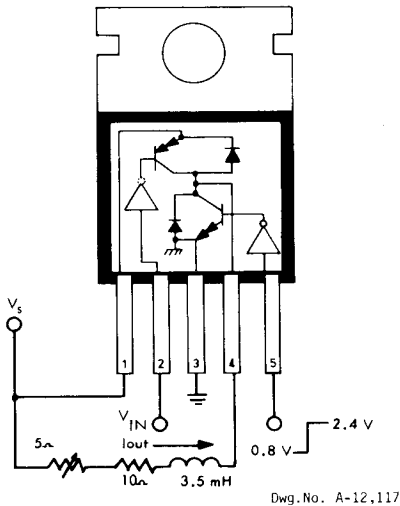

TEST FIGURE 2

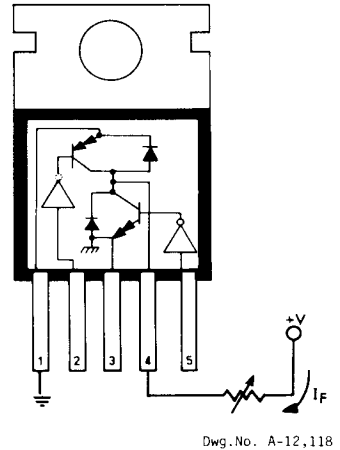

**APPLICATION NOTES**

It should be noted that an additional power dissipation component may arise from crossover currents flowing from supply to ground when current direction through the load is reversed. This is due to differences in the switching speeds between the source and sink drivers. Although the internal logic lockout protects these devices from catastrophic failure, the crossover power component can cause device operation at substantially higher junction temperatures.

If timing conditions are ignored, the magnitude of this power can be approximated as:

$$P_D = V_S \times I_C \times t \times f$$

where  $V_S$  = supply voltage

$I_C$  = crossover current ( $\approx 3.5$  A max.)

$t$  = crossover current duration ( $\approx 1$   $\mu$ s)

$f$  = frequency of direction change

In some applications (high switching speeds or high package power dissipation), it is recommended that the inputs be driven separately, and that the sink driver not be turned ON for at least 2  $\mu$ s (maximum source  $t_{pD}$ ) after the source driver input is turned OFF. The sink driver should be turned OFF at least 750 ns (maximum sink  $t_{pD}$ ) before the source driver is turned ON.

**RECOMMENDED TIMING CONDITIONS  
(UDN-2950Z shown)**

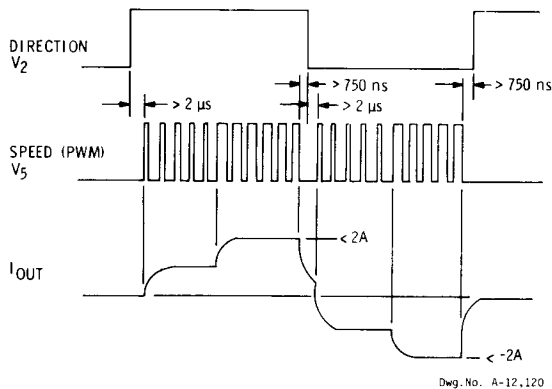

Dwg. No. A-12,120

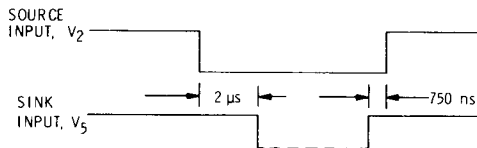

Dwg. No. A-12,119

TYPICAL APPLICATIONS

3-PHASE BRUSHLESS DC MOTOR DRIVE

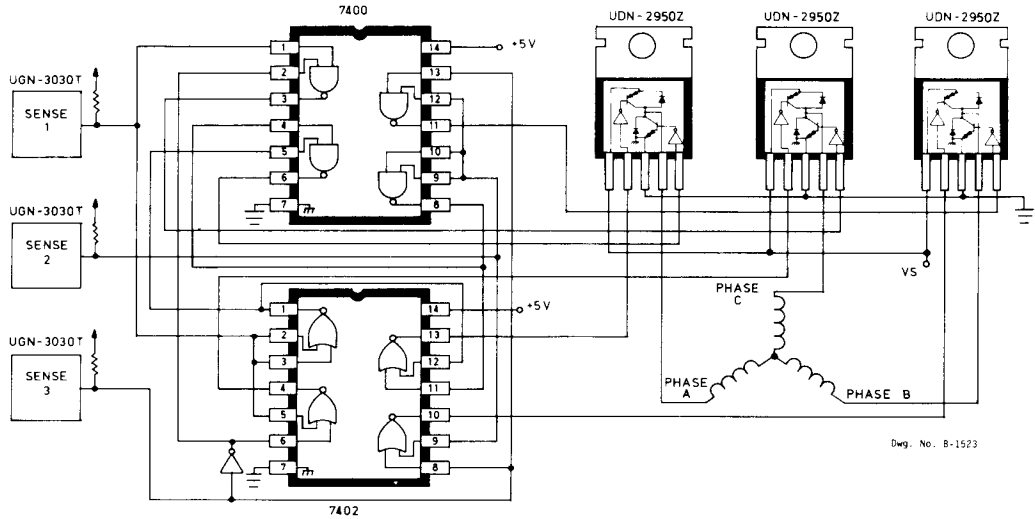

SINGLE-WINDING DC  
OR STEPPER MOTOR DRIVE

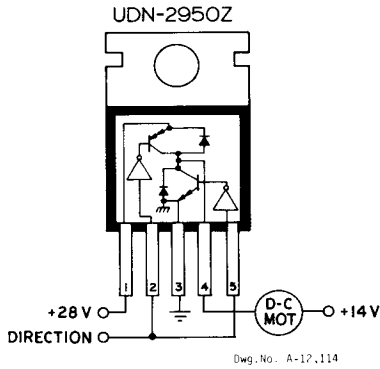

FULL-BRIDGE DC  
SERVO MOTOR DRIVE

