

© by Tony van Roon

The 555 timer IC was first introduced around 1971 by the Signetics Corporation as the SE555/NE555 and was called "**The IC Time Machine**" and was also the very first and only commercial timer ic available. It provided circuit designers and hobby tinkerers with a relatively cheap, stable, and user-friendly integrated circuit for both monostable and astable applications. Since this device was first made commercially available, a myriad of novel and unique circuits have been developed and presented in several trade, professional, and hobby publications. The past ten years some manufacturers stopped making these timers because of competition or other reasons. Yet other companies, like NTE (a subdivision of Philips) picked up where some left off.

This primer is about this fantastic timer which is after 30 years still very popular and used in many schematics. Although these days the CMOS version of this IC, like the Motorola MC1455, is mostly used, the regular type is still available, however there have been many improvements and variations in the circuitry. But all types are pin-for-pin plug compatible. Myself, every time I see this 555 timer used in advanced and high-tech electronic circuits, I'm amazed. It is just incredible.

In this tutorial I will show you what exactly the 555 timer is and how to properly use it by itself or in combination with other solid state devices without the requirement of an engineering degree. This timer uses a maze of transistors, diodes and resistors and for this complex reason I will use a more simplified (but accurate) block diagram to explain the internal organizations of the 555. So, lets start slowly and build it up from there.

Manufacturer	Type Number
ECG Philips	ECG955M
Exar	XR-555
Fairchild	NE555
Harris	HA555
Intersil	SE555/NE555
Lithic Systems	LC555
Motorola	MC1455/MC1555
National	LM1455/LM555C
NTE Sylvania	NTE955M
Raytheon	RM555/RC555
RCA	CA555/CA555C
Texas Instruments	SN52555/SN72555

(c) Tony van Roon

Table 1.

The first type-number, in Table 1 on the left, represents the type which was/is preferred for military applications which have somewhat improved electrical and thermal characteristics over their commercial counterparts, but also a bit more expensive, and usually metal-can or ceramic casing. This is analogous to the 5400/7400 series convention for TTL integrated circuits.

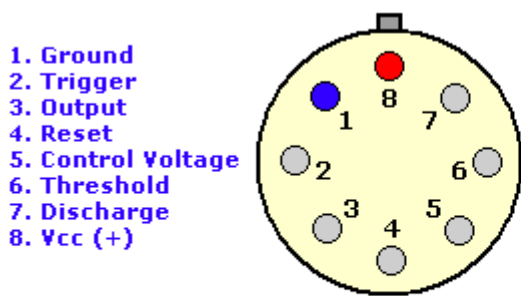

(c) Tony van Roon

fig. 1. 8-pin T package

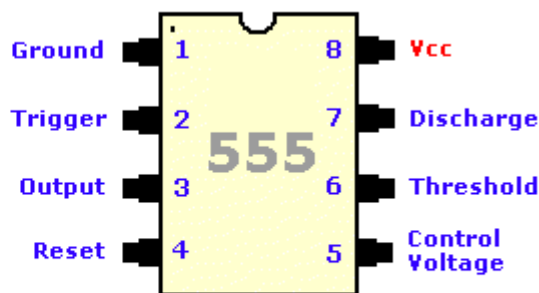
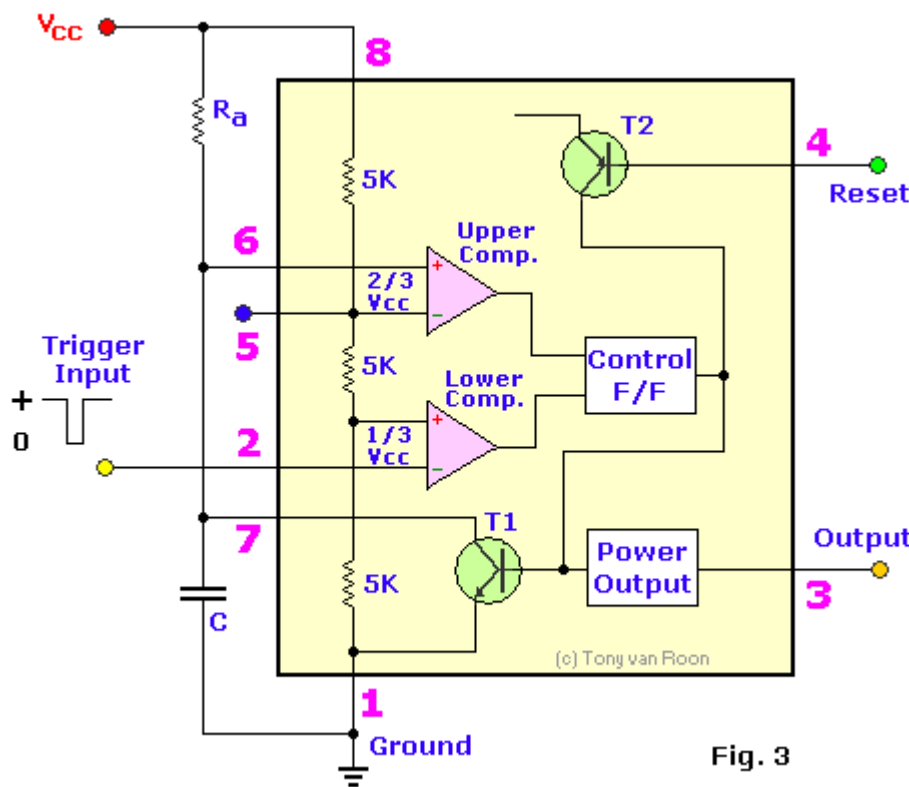

fig. 2. 8-pin V package

The 555, in fig. 1 and fig. 2 above, come in two packages, either the round metal-can called the 'T' package or the more familiar 8-pin DIP 'V' package. About 20-years ago the metal-can type was pretty much the standard (SE/NE types). The 556 timer is a dual 555 version and comes in a 14-pin DIP package, the 558 is a quad version with four 555's also in a 14 pin DIP case.



(c) Tony van Roon

Fig. 3

Inside the 555 timer, at fig. 3, are the equivalent of over 20 transistors, 15 resistors, and 2 diodes, depending of the manufacturer. The equivalent circuit, in block diagram, providing the functions of control, triggering, level sensing or comparison, discharge, and power output. Some of the more attractive features of the 555 timer are: Supply voltage between 4.5 and 18 volt, supply current 3 to 6 mA, and a Rise/Fall time of 100 nSec. It can also withstand quite a bit of abuse.

The Threshold current determine the maximum value of $R_a + R_b$. For 15 volt operation the

maximum total resistance for R ($R_a + R_b$) is 20 Mega-ohm.

The supply current, when the output is 'high', is typically 1 milli-amp (mA) or less. The initial monostable timing accuracy is typically within 1% of its calculated value, and exhibits negligible (0.1%/V) drift with supply voltage. Thus longterm supply variations can be ignored, and the temperature variation is only 50ppm/°C (0.005%/°C).

Trigger  Additional pulse has

All IC timers rely upon an external capacitor to determine the off-on time

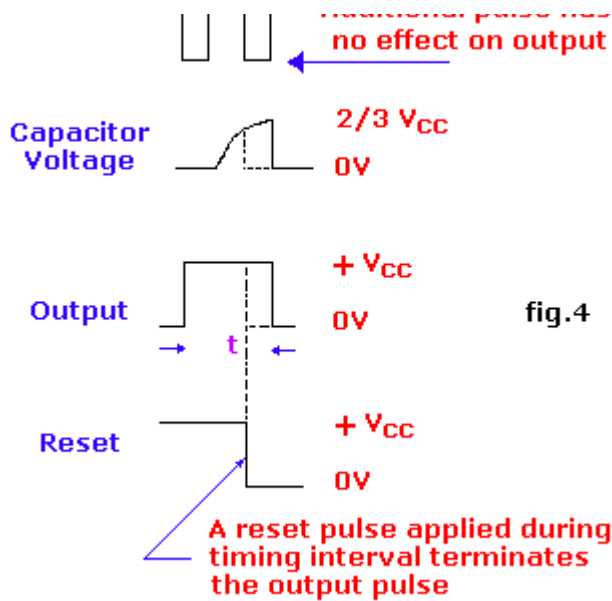

(c) Tony van Rooy

intervals of the output pulses. As you recall from your study of basic electronics, it takes a finite period of time for a capacitor (C) to charge or discharge through a resistor (R). Those times are clearly defined and can be calculated given the values of resistance and capacitance.

The basic RC charging circuit is shown in fig. 4. Assume that the capacitor is initially discharged. When the switch is closed, the capacitor begins to charge through the resistor. The voltage across the capacitor rises from zero up to the value of the applied DC voltage. The charge curve for the circuit is shown in fig. 6. The time that it takes for the capacitor to charge to 63.7% of the applied voltage is known as the time constant (t). That time can be

calculated with the simple expression:

$$t = R \times C$$

Assume a resistor value of 1 MegaOhm and a capacitor value of 1uF (micro-Farad). The time constant in that case is:

$$t = 1,000,000 \times 0.000001 = 1 \text{ second}$$

Assume further that the applied voltage is 6 volts. That means that it will take one time constant for the voltage across the capacitor to reach 63.2% of the applied voltage. Therefore, the capacitor charges to approximately 3.8 volts in one second.

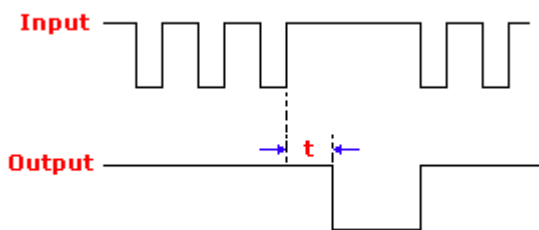
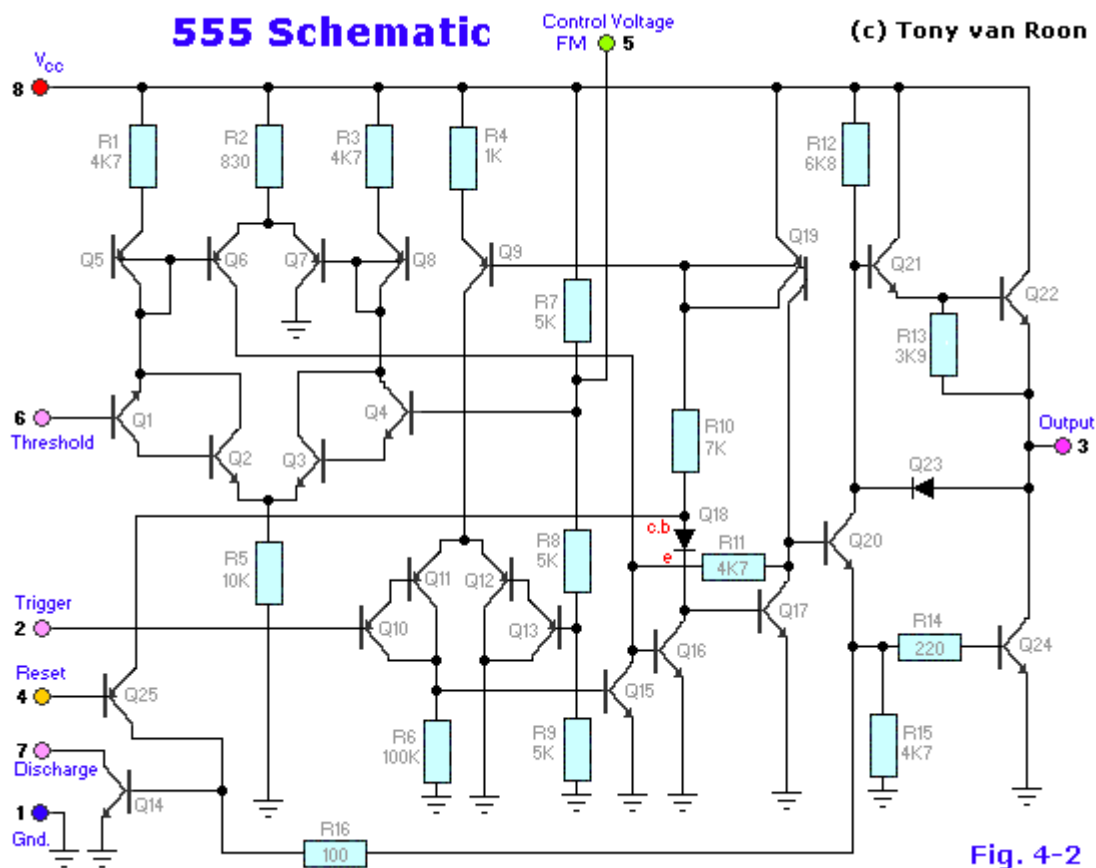

Fig. 4-1

Fig. 4-1, Change in the input pulse frequency allows completion of the timing cycle. As a general rule, the monostable 'ON' time is set approximately 1/3 longer than the expected time between triggering pulses. Such a circuit is also known as a 'Missing Pulse Detector'.

Looking at the curve in fig. 6, you can see that it takes approximately 5 complete time constants for the capacitor to charge to almost the applied voltage. It would take about 5 seconds for the voltage on the capacitor to rise to approximately the full 6-volts.



Definition of Pin Functions:

Refer to the internal 555 schematic of Fig. 4-2

Pin 1 (Ground): The ground (or common) pin is the most-negative supply potential of the device, which is normally connected to circuit common when operated from positive supply voltages.

Pin 2 (Trigger): This pin is the input to the lower comparator and is used to set the latch, which in turn causes the output to go high. This is the beginning of the timing sequence in monostable operation. Triggering is accomplished by taking the pin from above to below a voltage level of $1/3 V+$ (or, in general, one-half the voltage appearing at pin 5). The action of the trigger input is level-sensitive, allowing slow rate-of-change waveforms, as well as pulses, to be used as trigger sources.

One precaution that should be observed with the trigger input signal is that it must not remain lower than $1/3 V+$ for a period of time *longer* than the timing cycle. If this is allowed to happen, the timer will retrigger itself upon termination of the first output pulse. Thus, when the timer is driven in the monostable mode with input pulses longer than the desired output pulse width, the input trigger should effectively be shortened by differentiation.

The minimum-allowable pulse width for triggering is somewhat dependent upon pulse level, but in general if it is greater than the 1 μ S (micro-Second), triggering will be reliable.

A second precaution with respect to the trigger input concerns storage time in the lower comparator. This portion of the circuit can exhibit normal turn-off delays of several microseconds after triggering; that is, the latch can still have a trigger input for this period of time *after* the trigger pulse. In practice, this means the minimum monostable output pulse width should be in the order of 10 μ S to prevent possible double triggering due to this effect.

The voltage range that can safely be applied to the trigger pin is between V_+ and ground. A dc current, termed the *trigger* current, must also flow from this terminal into the external circuit. This current is typically 500nA (nano-amp) and will define the upper limit of resistance allowable from pin 2 to ground. For an astable configuration operating at $V_+ = 5$ volts, this resistance is 3 Mega-ohm; it can be greater for higher V_+ levels.

Pin 3 (Output): The output of the 555 comes from a high-current totem-pole stage made up of transistors Q20 - Q24. Transistors Q21 and Q22 provide drive for source-type loads, and their Darlington connection provides a high-state output voltage about 1.7 volts less than the V_+ supply level used. Transistor Q24 provides current-sinking capability for low-state loads referred to V_+ (such as typical TTL inputs). Transistor Q24 has a low saturation voltage, which allows it to interface directly, with good noise margin, when driving current-sinking logic. Exact output saturation levels vary markedly with supply voltage, however, for both high and low states. At a V_+ of 5 volts, for instance, the low state $V_{ce(sat)}$ is typically 0.25 volts at 5 mA. Operating at 15 volts, however, it can sink 100mA if an output-low voltage level of 2 volts is allowable (power dissipation should be considered in such a case, of course). High-state level is typically 3.3 volts at $V_+ = 5$ volts; 13.3 volts at $V_+ = 15$ volts. Both the rise and fall times of the output waveform are quite fast, typical switching times being 100nS.

The state of the output pin will always reflect the inverse of the logic state of the latch, and this fact may be seen by examining Fig. 3. Since the latch itself is not directly accessible, this relationship may be best explained in terms of latch-input trigger conditions. To trigger the output to a high condition, the trigger input is momentarily taken from a higher to a lower level. [see "Pin 2 - Trigger"]. This causes the latch to be set and the output to go high. Actuation of the lower comparator is the only manner in which the output can be placed in the high state. The output can be returned to a low state by causing the threshold to go from a lower to a higher level [see "Pin 6 - Threshold"], which resets the latch. The output can also be made to go low by taking the reset to a low state near ground [see "Pin 4 - Reset"].

Pin 4 (Reset): This pin is also used to reset the latch and return the output to a low state. The reset voltage threshold level is 0.7 volt, and a sink current of 0.1mA from this pin is required to reset the device. These levels are relatively independent of operating V_+ level; thus the reset input is TTL compatible for any supply voltage.

The reset input is an overriding function; that is, it will force the output to a low state regardless of the state of either of the other inputs. It may thus be used to terminate an output pulse prematurely, to gate oscillations from "on" to "off", etc. Delay time from reset to output is typically on the order of 0.5 μ S, and the minimum reset pulse width is 0.5 μ S. Neither of these figures is guaranteed, however, and *may vary* from one manufacturer to another. When not used, it is recommended that the reset input be tied to V_+ to avoid any possibility of false resetting.

Pin 5 (Control Voltage): This pin allows direct access to the $2/3 V_+$ voltage-divider point, the reference level for the upper comparator. It also allows indirect access to the lower comparator, as there is a 2:1 divider (R8 - R9) from this point to the lower-comparator reference input, Q13. Use of this terminal is the option of the user, but it does allow extreme flexibility by permitting modification of the timing period, resetting of the comparator, etc.

When the 555 timer is used in a voltage-controlled mode, its voltage-controlled operation ranges from about 1 volt less than V_+ down to within 2 volts of ground (although this is not guaranteed). Voltages can be safely applied outside these limits, but they should be confined within the limits of V_+ and ground for reliability.

In the event the control-voltage pin is not used, it is recommended that it be bypassed with a capacitor of about 0.01 μ F (10nF) for immunity to noise, since it is a comparator input.

Pin 6 (Threshold): Pin 6 is one input to the upper comparator (the other being pin 5) and is used to reset the latch, which causes the output to go low.

Resetting via this terminal is accomplished by taking the terminal from below to above a voltage level of $2/3 V+$ (the normal voltage on pin 5). The action of the threshold pin is level sensitive, allowing slow rate-of-change waveforms.

The voltage range that can safely be applied to the threshold pin is between $V+$ and ground. A dc current, termed the *threshold* current, must also flow into this terminal from the external circuit. This current is typically 100nA, and will define the upper limit of total resistance allowable from pin 6 to $V+$. For either timing configuration operating at $V+ = 5$ volts, this resistance is 16 Mega-ohm.

Pin 7 (Discharge): This pin is the open collector of an npn transistor (Q14), the emitter of which goes to ground. The conduction state of this transistor is identical in timing to that of the output stage. It is "on" (low resistance to ground) when the output is low and "off" (high resistance to ground) when the output is high.

In both the monostable and astable time modes, this transistor switch is used to clamp the appropriate nodes of the timing network to ground. Saturation voltage is typically below 100mV (milli-Volt) for currents of 5 mA or less, and off-state leakage is about 20nA (these parameters are not specified by all manufacturers, however).

Maximum collector current is internally limited by design, thereby removing restrictions on capacitor size due to peak pulse-current discharge. In certain applications, this open collector output can be used as an auxiliary output terminal, with current-sinking capability similar to the output (pin 3).

Pin 8 ($V+$): The $V+$ pin (also referred to as V_{cc}) is the positive supply voltage terminal of the 555 timer IC. Supply-voltage operating range for the 555 is +4.5 volts (minimum) to +16 volts (maximum), and it is specified for operation between +5 volts and +15 volts. The device will operate essentially the same over this range of voltages without change in timing period. Actually, the most significant operational difference is the output drive capability, which increases for both current and voltage range as the supply voltage is increased. Sensitivity of time interval to supply voltage change is low, typically 0.1% per volt.

555 Timer Tester

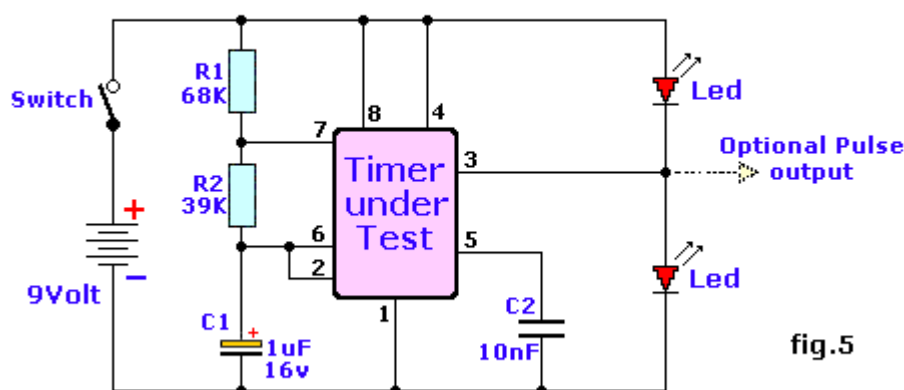

Try the simple 555 testing-circuit of Fig. 5. to get you going, and test all your 555 timer ic's. I build several for friends and family. I bring my own tester to ham-fests and what not to instantly do a check and see if they are oscillating. Or use as a trouble shooter in 555 based circuits. This tester will quickly tell you if the timer is functional or not. Although not foolproof, it

will tell if the 555 is shorted or oscillating. If both Led's are flashing the timer is most likely in good working order. If one or both Led's are either off or on solid the timer is defective. Simple huh?

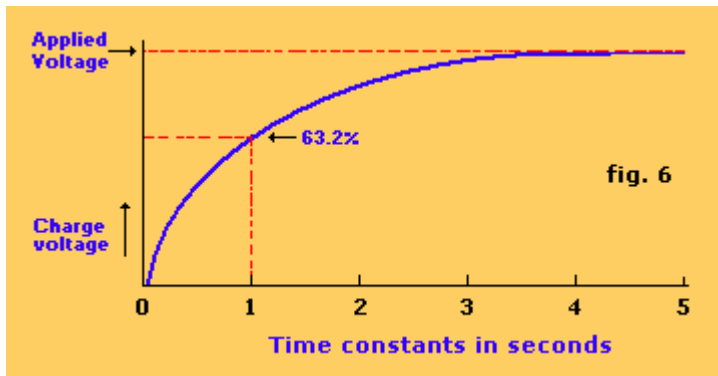

The capacitor slows down as it charges, and in actual fact never reaches the full supply voltage. That being the case, the maximum charge it receives in the timing circuit (66.6% of the supply voltage) is a little over the charge received after a time constant (63.2%).

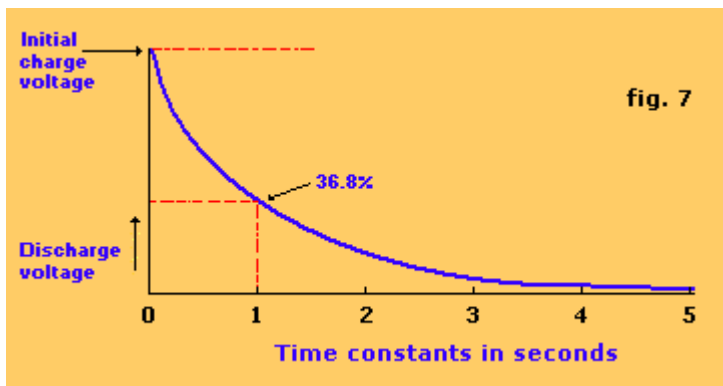

The capacitor slows down as it discharges, and never quite reaches the ground potential. That means the minimum voltage it operates at must be greater than zero. Timing circuit is 63.2% of the supply voltage.

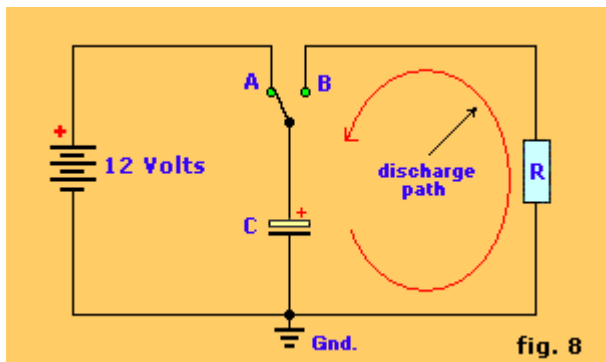

The discharge of a capacitor also takes time and we can shorten the amount of time by decreasing resistance (R) to the flow of current.

Operating Modes: The 555 timer has two basic operational modes: one shot and astable. In the one-shot mode, the 555 acts like a monostable multivibrator. A monostable is said to have a single stable state--that is the off state. Whenever it is triggered by an input pulse, the monostable switches to its temporary state. It remains in that state for a period of time determined by an RC network. It then returns to its stable state. In other words, the monostable circuit generates a single pulse of a fixed time duration each time it receives and input trigger pulse. Thus the name one-shot. One-shot multivibrators are used for turning some circuit or external component on or off for a specific length of time. It is also used to generate delays. When multiple one-shots are cascaded, a variety of sequential timing pulses can be generated. Those pulses will allow you to time and sequence a number of related operations.

The other basic operational mode of the 555 is as an astable multivibrator. An astable multivibrator is simply an oscillator. The astable multivibrator generates a continuous stream of rectangular off-on pulses that switch between two voltage levels. The frequency of the pulses and their duty cycle are dependent upon the RC network values.

One-Shot Operation: Fig. 4 shows the basic circuit of the 555 connected as a monostable multivibrator. An external RC network is connected between the supply voltage and ground. The junction of the resistor and capacitor is connected to the threshold input which is the input to the upper comparator. The internal discharge transistor is also connected to the junction of the resistor and the capacitor. An input trigger pulse is applied to the trigger input, which is the input to the lower comparator.

With that circuit configuration, the control flip-flop is initially reset. Therefore, the output voltage is near zero volts. The signal from the control flip-flop causes T1 to conduct and act as a short circuit across the external capacitor. For that reason, the capacitor cannot charge. During that time, the input to the upper comparator is near zero volts causing the comparator output to keep the control flip-flop reset.

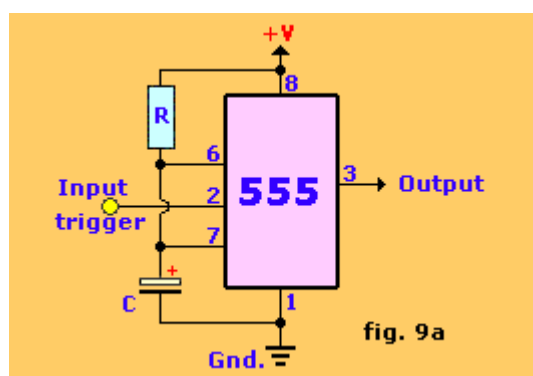

Notice how the monostable continues to output its pulse regardless of the inputs swing back up. That is because the output is only triggered by the input pulse, the output actually depends on the capacitor charge.

Monostable Mode:

The 555 in fig. 9a is shown here in its utmost basic mode of operation; as a triggered monostable. One immediate observation is the extreme simplicity of this circuit. Only two components to make up a timer, a capacitor and a resistor. And for noise immunity maybe a capacitor on pin 5. Due to the internal latching mechanism of the 555, the timer will always time-out once triggered, regardless of any subsequent noise (such as bounce) on the input trigger (pin 2). This is a great asset in interfacing the 555 with noisy sources. Just in case you don't know what 'bounce' is: bounce is a type of fast, short term noise caused by a switch, relay, etc. and then picked up by the input pin.

The trigger input is initially high (about $1/3$ of $+V$). When a negative-going trigger pulse is applied to the trigger input (see fig. 9a), the threshold on the lower comparator is exceeded. The lower comparator, therefore, sets the flip-flop. That causes T1 to cut off, acting as an open circuit. The setting of the flip-flop also causes a positive-going output level which is the beginning of the output timing pulse.

The capacitor now begins to charge through the external resistor. As soon as the charge on the capacitor equals $2/3$ of the supply voltage, the upper comparator triggers and resets the control flip-flop. That terminates the output pulse which switches back to zero. At this time, T1 again conducts thereby discharging the capacitor. If a negative-going pulse is applied to the reset input while the output pulse is high, it will be terminated immediately as that pulse will reset the flip-flop.

Whenever a trigger pulse is applied to the input, the 555 will generate its single-duration output

pulse. Depending upon the values of external resistance and capacitance used, the output timing pulse may be adjusted from approximately one millisecond to as high as on hundred seconds. For time intervals less than approximately 1-millisecond, it is recommended that standard logic one-shots designed for narrow pulses be used instead of a 555 timer. IC timers are normally used where long output pulses are required. In this applicaton, the duration of the output pulse in seconds is approximately equal to:

$$T = 1.1 \times R \times C \text{ (in seconds)}$$

The output pulse width is defined by the above formula and with relatively few restrictions, timing components R(t) and C(t) can have a wide range of values. There is actually no theoretical upper limit on T (output pulse width), only practical ones. The lower limit is 10uS. You may consider the range of T to be 10uS to infinity, bounded only by R and C limits. Special R(t) and C(t) techniques allow for timing periods of days, weeks, and even months if so desired. However, a reasonable lower limit for R(t) is in the order of about 10Kilo ohm, mainly from the standpoint of power economy. (Although R(t) can be lower than 10K without harm, there is no need for this from the standpoint of achieving a short pulse width.) A practical minimum for C(t) is about 95pF; below this the stray effects of capacitance become noticeable, limiting accuracy and predictability. Since it is obvious that the product of these two minimums yields a T that is less than 10uS, there is much flexibility in the selection of R(t) and C(t). Usually C(t) is selected first to minimize size (and expense); then R(t) is chosen.

The upper limit for R(t) is in the order of about 15 Mega ohm but should be less than this if all the accuracy of which the 555 is capable is to be achieved. The absolute upper limit of R(t) is determined by the threshold current plus the discharge leakage when the operating voltage is +5 volt. For example, with a threshold plus leakage current of 120nA, this gives a maximum value of 14M for R(t) (very optimistic value). Also, if the C(t) leakage current is such that the sum of the threshold current and the leakage current is in excess of 120 nA the circuit will never time-out because the upper threshold voltage will not be reached. Therefore, it is good practice to select a value for R(t) so that, with a voltage drop of 1/3 V+ across it, the value should be 100 times more, if practical.

So, it should be obvious that the real limit to be placed on C(t) is its leakage, not its capacitance value, since larger-value capacitors have higher leakages as a fact of life. Low-leakage types, like tantalum or NPO, are available and preferred for long timing periods. Sometimes input trigger source conditions can exist that will necessitate some type of signal conditioning to ensure compatibility with the triggering requirements of the 555. This can be achieved by adding another capacitor, one or two resistors and a small signal diode to the input to form a pulse differentiator to shorten the input trigger pulse to a width less than 10uS (in general, less than T). Their values and criterion are not critical; the main one is that the width of the resulting differentiated pulse (after C) should be *less* than the desired output pulse for the period of time it is below the 1/3 V+ trigger level.

There are several different types of 555 timers. The LM555 from National is the most common one these days, in my opinion. The Exar XR-L555 timer is a micropower version of the standard 555 offering a direct, pin-for-pin (also called plug-compatible) substitute device with an advantage of a lower power operation. It is capable of operation of a wider range of positive supply voltage from as low as 2.7volt minimum up to 18 volts maximum. At a supply voltage of +5V, the L555 will typically dissipate of about 900 microwatts, making it ideally suitable for battery operated circuits. The internal schematic of the L555 is very much similar to the standard 555 but with additional features like 'current spiking' filtering, lower output drive capability, higher nodal impedances, and better noise reduction system.

Intersil's ICM7555 model is a low-power, general purpose CMOS design version of the standard

555, also with a direct pin-for-pin compatibility with the regular 555. Its advantages are very low timing/bias currents, low power-dissipation operation and an even wider voltage supply range of as low as 2.0 volts to 18 volts. At 5 volts the 7555 will dissipate about 400 microwatts, making it also very suitable for battery operation. The internal schematic of the 7555 (not shown) is however totally different from the normal 555 version because of the different design process with cmos technology. It has much higher input impedances than the standard bipolar transistors used. The cmos version removes essentially any timing component restraints related to timer bias currents, allowing resistances as high as practical to be used.

This very versatile version should be considered where a wide range of timing is desired, as well as low power operation and low current sync'ing appears to be important in the particular design. A couple years after Intersil, Texas Instruments came on the market with another cmos variation called the LINCOS (LINEAR CMOS) or Turbo 555. In general, different manufacturers for the cmos 555's reduced the current from 10mA to 100 μ A while the supply voltage minimum was reduced to about 2 volts, making it an ideal type for 3v applications. The cmos version is the choice for battery powered circuits. However, the negative side for the cmos 555's is the reduced output current, both for sync and source, but this problem can be solved by adding a amplifier transistor on the output if so required. For comparison, the regular 555 can easily deliver a 200mA output versus 5 to 50mA for the 7555. On the workbench the regular 555 reached a limited output frequency of 180Khz while the 7555 easily surpassed the 1.1Mhz mark and the TLC555 stopped at about 2.4Mhz. Components used were 1% Resistors and low-leakage capacitors, supply voltage used was 10volt.

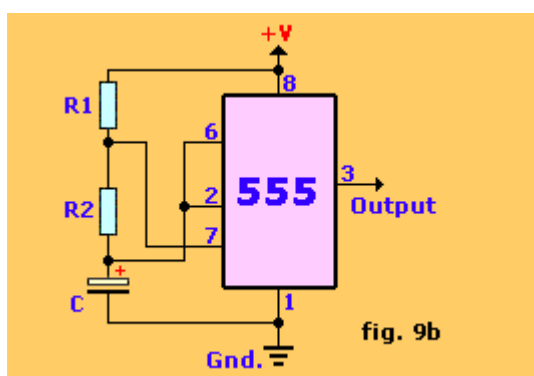

Astable operation: Figure 9b shows the 555 connected as an astable multivibrator. Both the trigger and threshold inputs (pins 2 and 6) to the two comparators are connected together and to the external capacitor. The capacitor charges toward the supply voltage through the two resistors, R1 and R2. The discharge pin (7) connected to the internal transistor is connected to the junction of those two resistors.

When power is first applied to the circuit, the capacitor will be uncharged, therefore, both the trigger and threshold inputs will be near zero volts (see Fig. 10). The lower comparator sets the control flip-flop causing the output to switch high. That also turns off transistor T1. That allows the capacitor to begin charging through R1 and R2. As soon as the charge on the capacitor reaches 2/3 of the supply voltage, the upper comparator will trigger causing the flip-flop to reset. That causes the output to switch low. Transistor T1 also conducts. The effect of T1 conducting causes resistor R2 to be connected across the external capacitor. Resistor R2 is effectively connected to ground through internal transistor T1. The result of that is that the capacitor now begins to discharge through R2.

The only difference between the single 555, dual 556, and quad 558 (both 14-pin types), is the common power rail. For the rest everything remains the same as the single version, 8-pin 555.

As soon as the voltage across the capacitor reaches 1/3 of the supply voltage, the lower comparator is triggered. That again causes the control flip-flop to set and the output to go high. Transistor T1 cuts off and again the capacitor begins to charge. That cycle continues to repeat with the capacitor alternately charging and discharging, as the

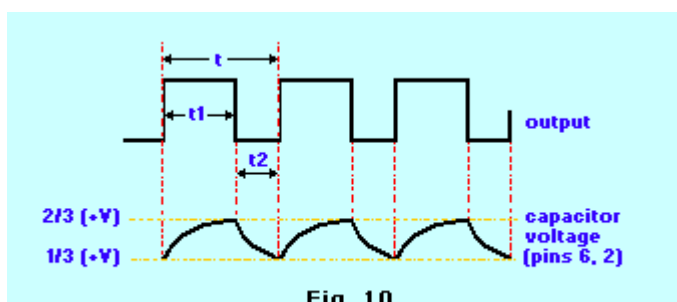

comparators cause the flip-flop to be repeatedly set and reset. The resulting output is a continuous stream of rectangular pulses.

The frequency of operation of the astable circuit is dependent upon the values of R1, R2, and C. The frequency can be calculated with the formula:

$$f = 1/(.693 \times C \times (R1 + 2 \times R2))$$

The Frequency f is in Hz, R1 and R2 are in ohms, and C is in farads.

The time duration between pulses is known as the 'period', and usually designated with a 't'. The pulse is on for t1 seconds, then off for t2 seconds. The total period (t) is t1 + t2 (see fig. 10).

That time interval is related to the frequency by the familiar relationship:

$$f = 1/t$$

OR

$$t = 1/f$$

The time intervals for the on and off portions of the output depend upon the values of R1 and R2. The ratio of the time duration when the output pulse is high to the total period is known as the duty-cycle. The duty-cycle can be calculated with the formula:

$$D = t1/t = (R1 + R2) / (R1 + 2R2)$$

You can calculate t1 and t2 times with the formulas below:

$$t1 = .693(R1+R2)C$$

$$t2 = .693 \times R2 \times C$$

The 555, when connected as shown in Fig. 9b, can produce duty-cycles in the range of approximately 55 to 95%. A duty-cycle of 80% means that the output pulse is on or high for 80% of the total period. The duty-cycle can be adjusted by varying the values of R1 and R2.

Applications:

There are literally thousands of different ways that the 555 can be used in electronic circuits. In almost every case, however, the basic circuit is either a one-shot or an astable.

The application usually requires a specific pulse time duration, operation frequency, and duty-cycle. Additional components may have to be connected to the 555 to interface the device to external circuits or devices.

In the remainder of this experiment, you will build both the one-shot and astable circuits and learn about some of the different kinds of applications that can be implemented. Furthermore, the last page of this document contains 555 examples which you can build and experiment with.

Required Parts:

In addition to a breadboard and a DC powersupply with a voltage in the 5 to 12 volt range, you will need the following components: 555 timer, LED, 2-inch /8 ohm loudspeaker, 150-ohm 1/4 watt resistor, two 10K ohm 1/4 resistors, two 1-Mega ohm 1/2 watt resistors, 10 Mega ohm 1/4 watt resistor, 0.1 uF capacitor, and a 0.68uF capacitor. All parts are available from Radio Shack or Tandy.

Experimental steps:

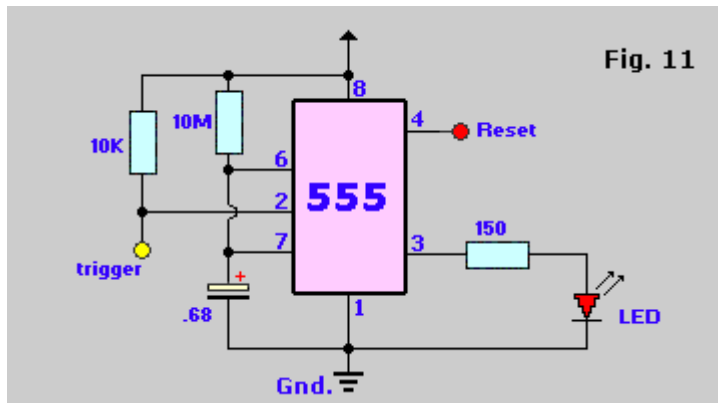

This circuit is resettable by grounding pin 4, so be sure to have an extra wire at pin 4 ready to test that feature.

1. On your breadboard, wire the one-shot circuit as shown in figure 11.
2. Apply power to the circuit. If you have a standard 5 volt logic supply, use it for convenience. You may use any voltage between 5 and 15 volts with a 555 timer. You can also run the circuit from battery power. A standard 9-volt battery will work perfectly. With the power connected, note the status of the LED:
is it on or off? _____
3. Connect a short piece of hook-up wire to the trigger input line on pin 2. Momentarily, touch that wire to ground. Remove it quickly. That will create a pulse at the trigger input. Note and record the state of LED: _____
4. Continue to observe the LED and note any change in the output state after a period of time. What is the state? _____
5. When you trigger the one-shot, time the duration of the output pulse with a stopwatch or the seconds hand on your watch. To do that, the instant that you trigger the one-shot by touching the wire to ground, immediately start your stopwatch or make note of the seconds hand on your watch. Trigger the one-shot and time the output pulse. Write in the approximate value of the pulse-duration: _____
6. Using the values of external resistor and capacitor values in Fig. 11 and the time interval formula for a one-shot, calculate the output-pulse duration. What is your value? _____
7. Compare your calculated and timed values of output pulses. Explain any discrepancies between your calculated and measured values.
Answer: _____
8. Connect a short piece of hook-up wire to pin 4. You will use that as a reset.
9. Trigger the one-shot as indicated previously. Then immediately touch the reset wire from pin 4 to ground. Note the LED result: _____
10. With a DC voltmeter, measure the output voltage at pin 3 during the one shot's off and on states. What are your values?
OFF: _____ volts ON: _____ volts.
11. Replace the 10 MegOhm resistor with a 1 MegOhm resistor and repeat steps 5 and 6. Record your timed and calculated results:
Timed: _____ seconds Calculated: _____ seconds

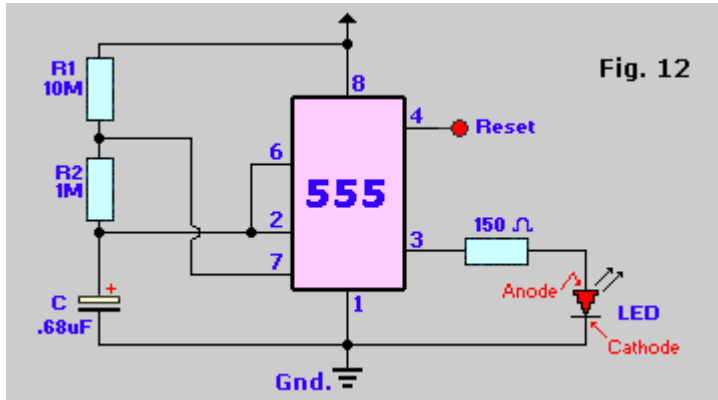

Fig. 12

If you want to get fancy, after you've completed the experiment you can replace the resistors with potentiometers to build a variable function generator and play with that to learn more.

12. Next you will experiment with astable circuits. First, rewire the circuit it appears as shown in Fig. 12.
13. Apply power to the circuit and observe the LED. What is happening?
Answer: _____
14. Replace the 10 MegOhm resistor with a 1 MegOhm resistor. Again observe the LED. Is the frequency higher or lower? _____
15. Using the formula given in the tutorial, calculate the oscillation frequency using R1 as 10 MegOhm, and again with R1 as 1 MegOhm, and again with R1 as 10 MegOhm. R2 is 1 MegOhm in both cases. Record your freq's:
 $f =$ _____ Hz (R1 = 10 MegOhm)
 $f =$ _____ Hz (R1 = 1 MegOhm)
16. Calculate the period, t1 and t2, and the duty-cycle for each resistor value
 10 MegOhm: $t =$ _____ $t1 =$ _____ $t2 =$ _____
 1 MegOhm: $t =$ _____ $t1 =$ _____ $t2 =$ _____

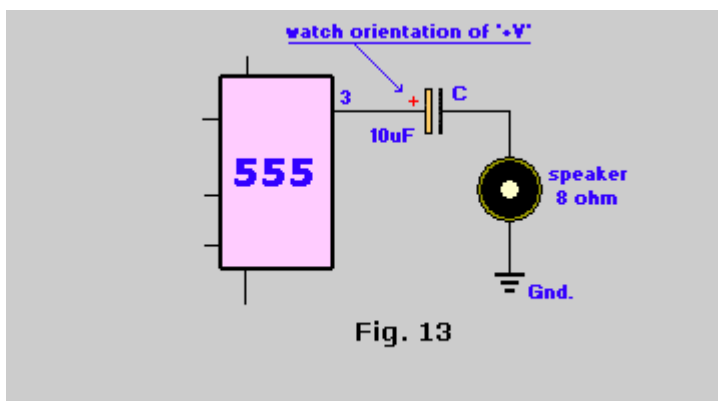

Fig. 13

Monitoring the timer with a speaker can be amusing if you switch capacitors or resistors to make an organ.

17. Rewire the circuit making R1 and R2 10,000 ohms and C equal to 0.1uF. Use the same circuit in Fig. 12. But, replace the LED and its resistor with a speaker and capacitor as shown in Fig. 13.
18. Apply power to the circuit and note the result: _____
19. Calculate the frequency of the circuit: $f =$ _____ Hz

20. If you have an oscilloscope, monitor the output voltage on pin 3. Disconnect the speaker and note the output. Also, observe the capacitor charge and discharge at pin 6 or 2: _____

Review of steps 1 through 20:

The circuit you built for those steps was a one-shot multi-vibrator. The circuit is similar to that described in the tutorial. The trigger input is held high with a 10,000 ohm resistor. When you bring pin 2 low, by touching the wire to ground, the one-shot is fired. The LED installed at the output of the 555 is used to monitor the output pulse. The LED goes on when the one-shot is triggered.

The component values selected for the circuit are large, so as to generate a long output pulse. That allows you to measure the pulse duration with a stop watch. Once the one-shot is triggered, the output LED stays on until the capacitor charges to 2/3 of the supply voltage. That triggers the upper comparator and causes the internal control flip-flop to reset, turning off the pulse and discharging the capacitor. The one-shot will remain in that state until it is triggered again. Timing the pulse should have produced an output duration of approximately 7.5 seconds. Calculating the output time interval using the formula given previously, you found the pulse duration to be:

$$t = 1.1 \times .68 \times 10^{-6} \times 10^7 = 7.48 \text{ seconds}$$

You may have notice some difference between the calculated and actual measured values. The differences probably result from inaccuracies in your timing. Further, component tolerances may be such that the actual values are different from the marked values.

In **steps 8 and 9** you demonstrated the reset function. As you saw, you could terminate the output pulse before the timing cycle is completed by touching pin 4 to ground. That instantly resets the flip-flop and shuts off the output pulse.

In **step 10**, you measured the output voltage. When off, the output is only a fraction of a volt. For all practical purposes it is zero. When triggered, the 555 generates a 3.5 volt pulse with a 5-volt supply. If you used another value of supply voltage, you would probably have discovered that the output during the pulse is about 1.5 volt less than the supply voltage.

In **step 11**, you lowered the resistor value to 1 Megohm. As you noticed, that greatly shortens the output pulse duration. The LED only stayed on for a brief time; so brief in fact that you probably couldn't time it accurately. The calculated duration of the output pulse is 0.748 seconds.

The circuit you built for **steps 12 - 20** was an astable multi-vibrator. The astable circuit is an oscillator whose frequency is dependent upon the R1, R2, and C values. In **step 13**, you should have found that the LED flashed off and on slowly.

The oscillation frequency is 0.176 Hz. That gives a period of:

$$t = 1/f = 1/.176 = 5.66 \text{ seconds}$$

Since R1 is larger than R2, the LED will be **on** for a little over 5 seconds and it will stay **off** for only 0.5 seconds. That translates to a duty-cycle of:

$$D = t_1/t = 5.18/5.66 = .915 \text{ or } 91.5\%$$

In **step 14**, you replaced the 10 MegOhm resistor with a 1 MegOhm resistor making both R1 and R2 equal. The new frequency is 0.706 Hz, much higher than in **step 13**. That translates to a period of 1.41 seconds. Calculating the t1 and t2 times, you see that the LED is on for 0.942 second and off for 0.467 second. That represents a duty-cycle of:

$$D = 0.942/1.41 = 0.67 \text{ or } 67\%$$

In **step 17**, you made $R1 = R2 = 10,000 \text{ ohm (10K)}$ and $C = 0.1\mu\text{F}$. That increased the frequency to 480Hz. The result should have been a loud tone in the speaker.

If you had used an oscilloscope, you saw the output to be a distorted rectangular wave of about 2 volts peak-to-peak. That distortion is caused by the speaker load. Removing it makes the waveform nice and square and the voltage rises to about 5 volts peak-to-peak. The capacitor waveform is a combination of the classical charge and discharge curves given earlier.

The time is useful in computer, function generators, clocks, music synthesizers, games, flashing lights, printers, scanners and the list goes on and on.

Example Circuits:

I have placed a couple of 555 circuit examples below for your convenience. Play with different component values and use the formulas mentioned earlier to calculate your results. Things to remember: For proper monostable operation with the 555 timer, the negative-going trigger pulse width should be kept short compared to the desired output pulse width. Values for the external timing resistor and capacitor can either be determined from the previous formulas. However, you should stay within the ranges of resistances shown earlier to avoid the use of large value electrolytic capacitors, since they tend to be leaky. Otherwise, tantalum or mylar types should be used. (For noise immunity on most timer circuits I recommend a 0.01μF (10nF) ceramic capacitor between pin 5 and ground.) In all circuit diagrams below I used the LM555CN timer IC from National, but the NE555 and others should not give you any problems

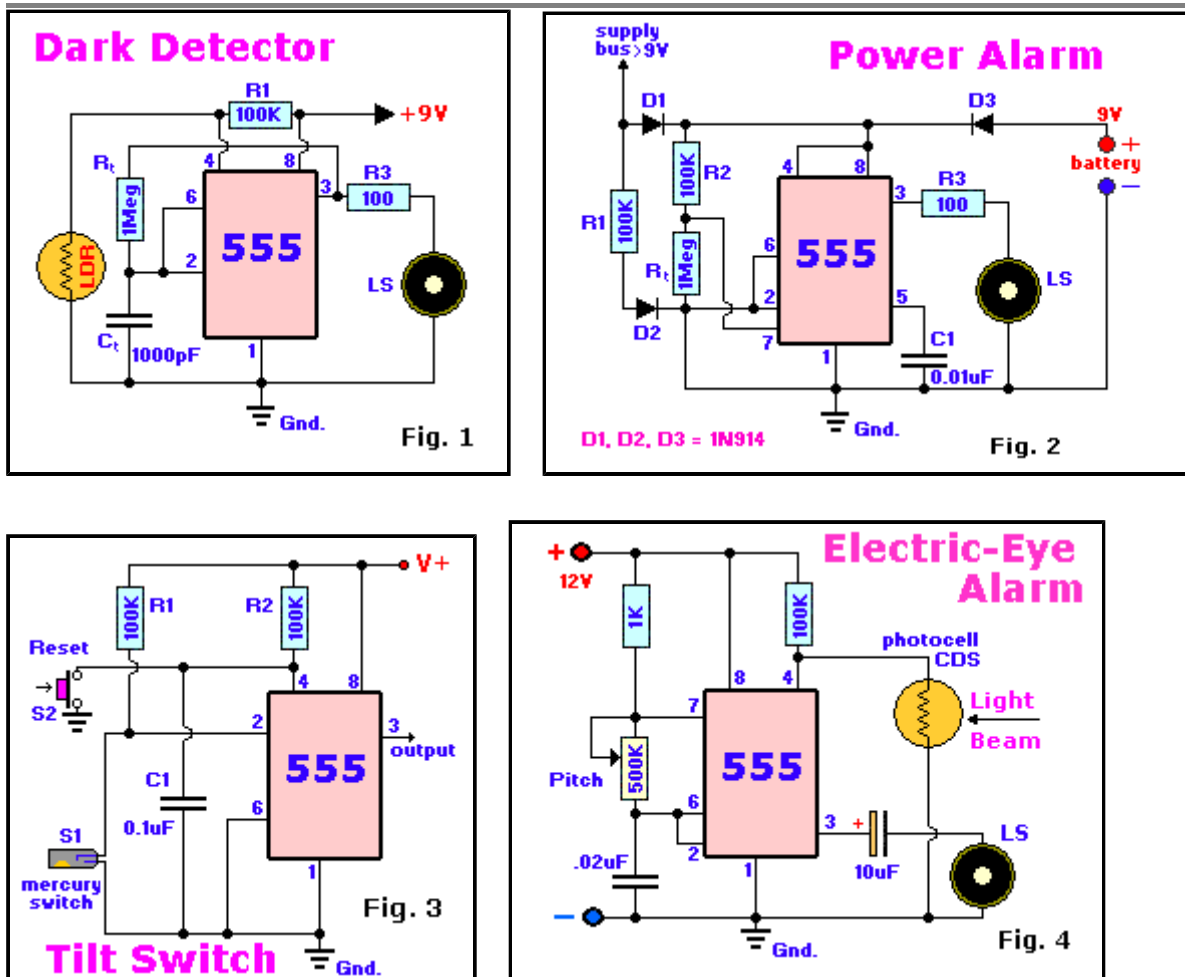

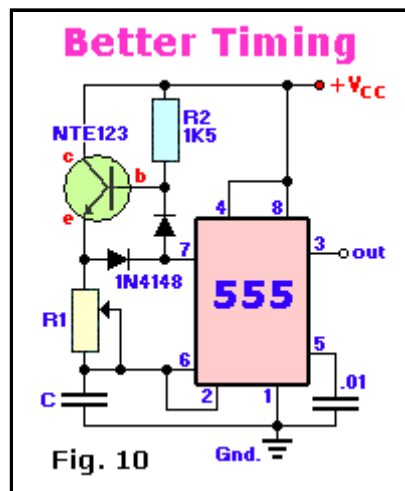
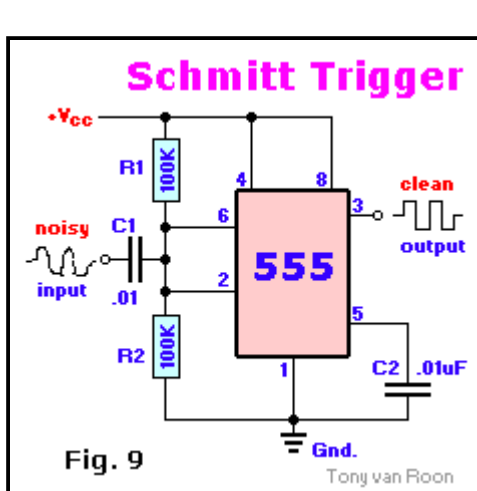
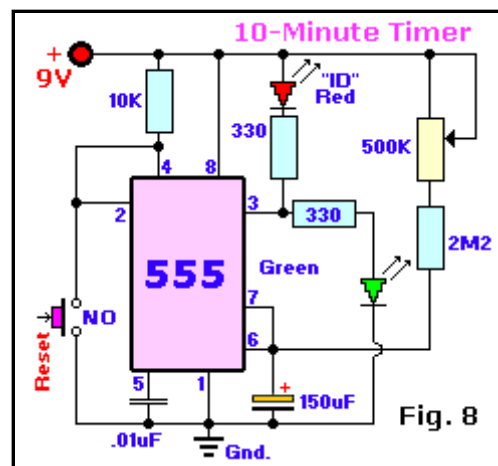
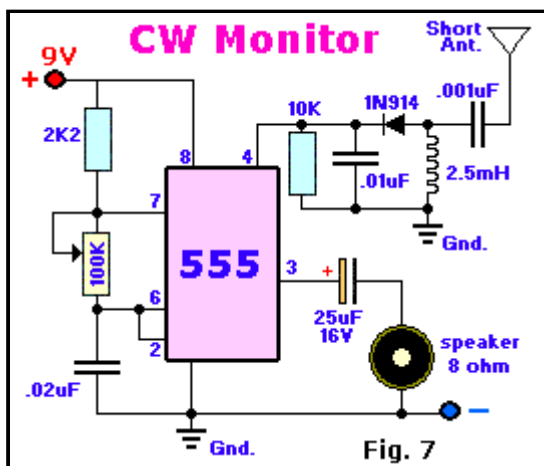
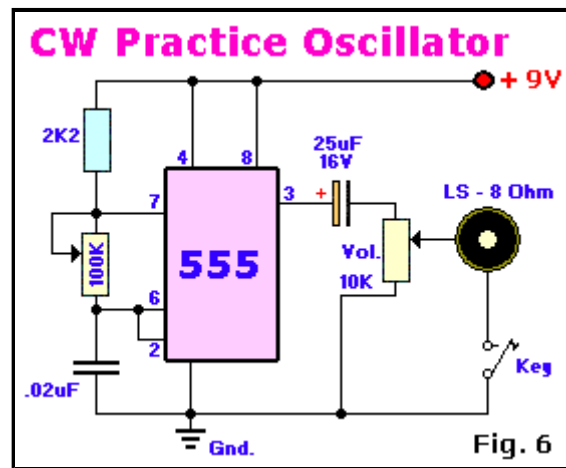
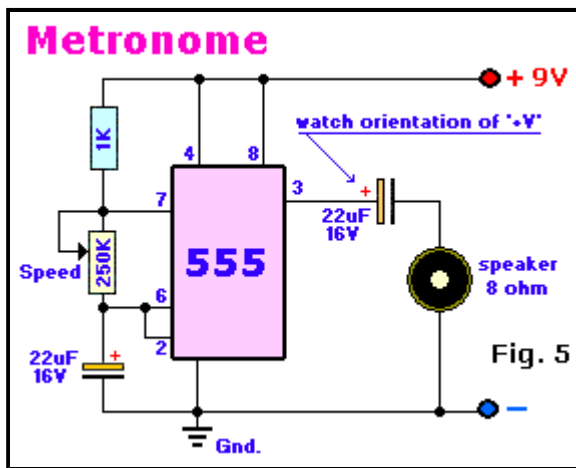

Circuits 1 to 10:

Play with different indicating devices such as bells, horns, lights, relays, or whatever (if possible). Try different types of LDR's. If for any reason you get false triggering, connect a ceramic 0.01uF (=10nF) capacitor between pin 5 (555) and ground. Keeping the basic rules of the 555 timer, try different values for Ct and Rt (or the C & R over pins 2, 6 & 7) Replace Rt with a 1 megohm potentiometer if you wish. Make notes of the values used and use the formulas to calculate timing. Verify your calculations with your timing.

Fig. 1, Dark Detector: It will sound an alarm if it gets too dark all over sudden. For example, this circuit could be used to notify when a lamp (or bulb) burns out. The detector used is a regular

cadmium-sulphide Light Dependent Resistor or **LDR**, for short, to sense the absence of light and to operate a small speaker. The LDR enables the alarm when light falls below a certain level.

Fig. 2, Power Alarm: This circuit can be used as a audible 'Power-out Alarm'. It uses the 555 timer as an oscillator biased off by the presence of line-based DC voltage. When the line voltage fails, the bias is removed, and the tone will be heard in the speaker. R1 and C1 provide the DC bias that charges capacitor Ct to over 2/3 voltage, thereby holding the timer output low (as you learned previously). Diode D1 provides DC bias to the timer-supply pin and, optionally, charges a rechargeable 9-volt battery across D2. And when the line power fails, DC is furnished to the timer through D2.

Fig. 3 Tilt Switch: Actually really a alarm circuit, it shows how to use a 555 timer and a small glass-encapsulated mercury switch to indicate 'tilt'. The switch is mounted in its normal 'open' position, which allows the timer output to stay low, as established by C1 on startup. When S1 is disturbed, causing its contacts to be bridged by the mercury blob, the 555 latch is set to a high output level where it will stay even if the switch is returned to its starting position. The high output can be used to enable an alarm of the visual or the audible type. Switch S2 will silent the alarm and reset the latch. C1 is a ceramic 0.1uF (=100 nano-Farad) capacitor.

Fig. 4, Electric Eye Alarm: The Electric-Eye Alarm is actually a similar circuit like the Dark Detector of Fig. 1. The same type of LDR is used. The pitch for the speaker can be set with the 500 kilo-ohm potentiometer. Watch for the orientation of the positive (+) of the 10uF capacitor. The '+' goes to pin 3.

Fig. 5, Metronome: A Metronome is a device used in the music industry. It indicates the ritme by a 'toc-toc' sound which speed can be adjusted with the 250K potentiometer. Very handy if you learning to play music and need to keep the correct ritme up.

Fig. 6, CW Practice Oscillator: CW stands for '*Contineous Wave*' or Morse-Code. You can practice the morse-code with this circuit. The 100K potmeter is for the 'pitch' and the 10K for the speaker volume. The "Key" is a morse code key.

Fig. 7, CW Monitor: This circuit monitors the morse code 'on-air' via the tuning circuit hookup to pin 4 and the short wire antenna. The 100K potmeter controls the tone-pitch.

Fig. 8, Ten-Minute Timer: Can be used as a time-out warning for Ham Radio. The Federal Communications Commission (FCC) requires the ham radio operator to identify his station by giving his call-sign at least every 10 minutes. This can be a problem, especially during lengthy conversations when it is difficult to keep track of time. The 555 is used as a one-shot so that a visual warning indicator becomes active after 10-minutes. To begin the cycle, the reset switch is pressed which causes the '*Green*' led to light up. After 10 minutes, set by the 500K potentiometer R1, the '*Red*' led will light to warn the operator that he must indentify.

Fig. 9, Schmitt Trigger: A very simple, but effective circuit. It cleans up any noisy input signal in a nice, clean and square output signal. In radio control (R/C) it will clean up noisy servo signals caused by rf interference by long servo leads. As long as R1 equals R2, the 555 will automatically be biased for any supply voltage in the 5 to 16 volt range. (Advanced Electronics: It should be noted that there is a 180-degree phase shift.) This circuit also lends itself to condition 60-Hz sine-wave reference signal taken from a 6.3 volt AC transformer before driving a series of binary or divide-by-N counters. The major advantage is that, unlike a conventional multivibrator type of squarer which devides the input frequency by 2, this method simply squares the 60-Hz sine wave reference signal without division.

Fig. 10, Better Timing: Better and more stable timing output is created with the addition of a transistor and a diode to the R-C timing network. The frequency can be varied over a wide range while maintaining a constant 50% duty-cycle. When the output is **high**, the transistor is biased into saturation by R2 so that the charging current passes through the transistor and R1 to C. When the output goes **low**, the discharge transistor (pin 7) cuts off the transistor and discharges the capacitor through R1 and the diode. The high & low periods are equal. The value of the capacitor (C) and the resistor (R1 or potmeter) is not given. It is a mere example of how to do it and the values are pending on the type of application, so choose your own values. The diode can be any small signal diode like the NTE519, 1N4148, 1N914 or 1N3063, but a high conductance Germanium or Schottky type for the diode will minimize the diode voltage drops in the transistor and diode. However, the transistor should have a high beta so that R2 can be large and still cause the transistor to saturate. The transistor can be a TUN (europe), NTE123, 2N3569 and most others.

The following circuits are examples of how a 555 timer IC assist in combination with another Integrated Circuit. Again, don't be afraid to experiment. Unless you circumvent the min and max parameters of the 555, it is very hard to destroy. Just have fun and learn something doing it.

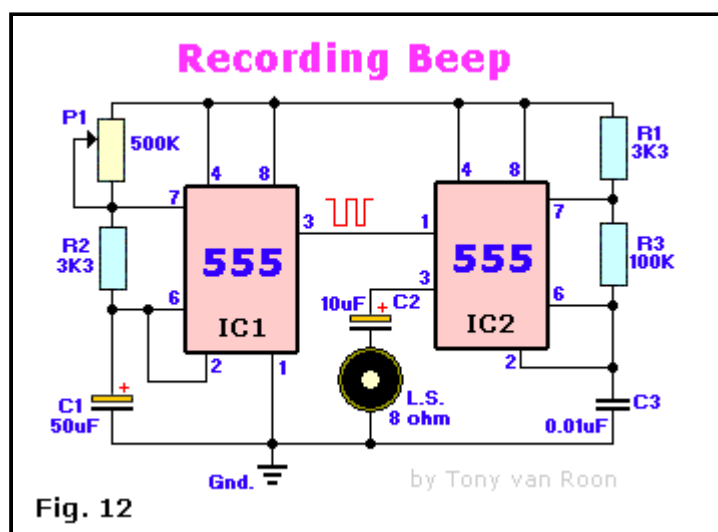
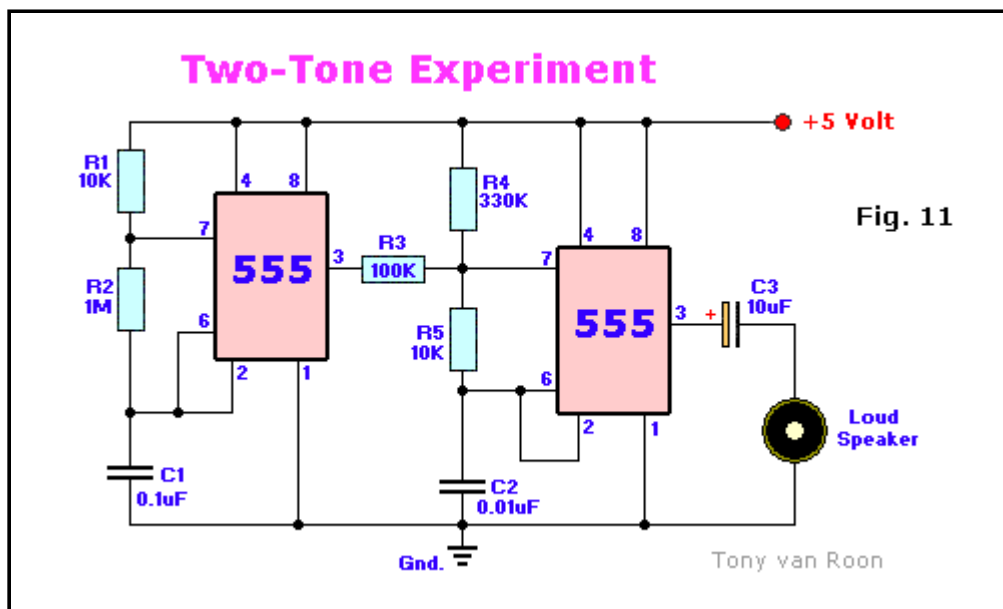

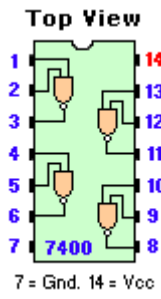
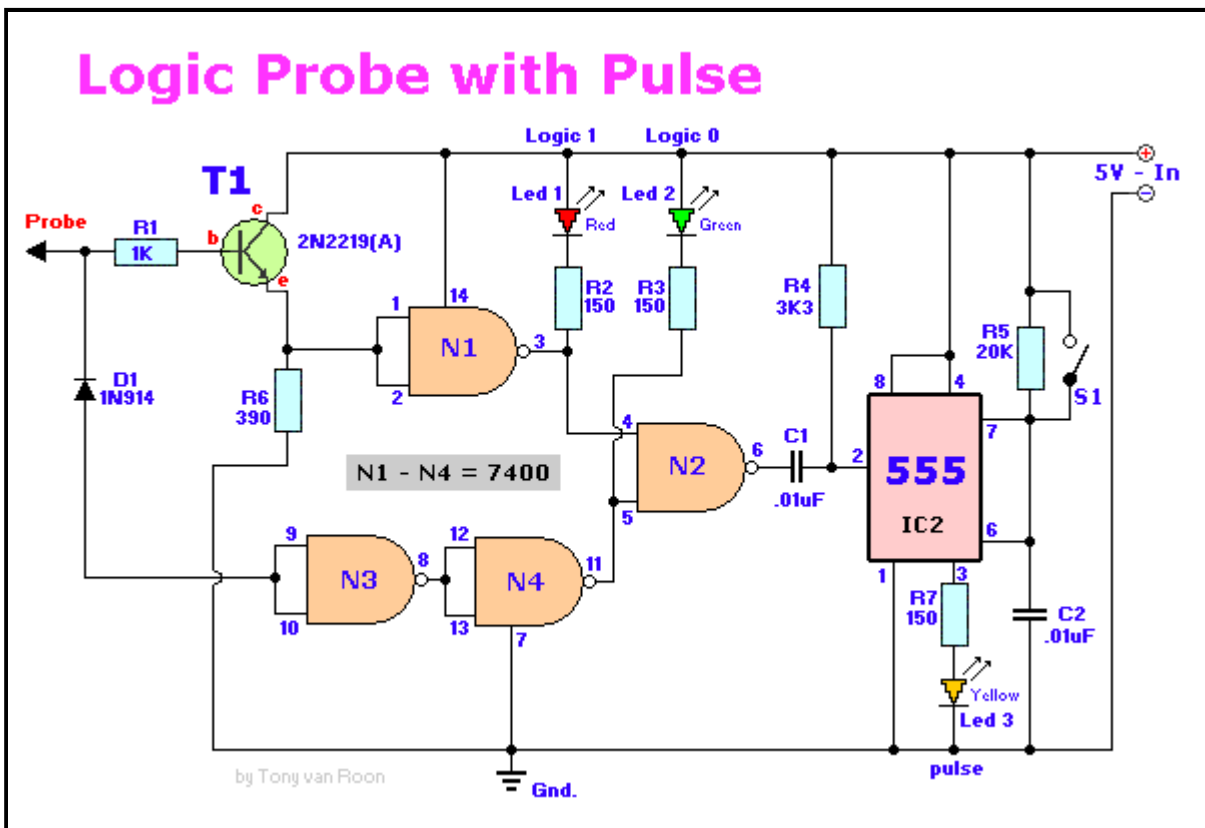
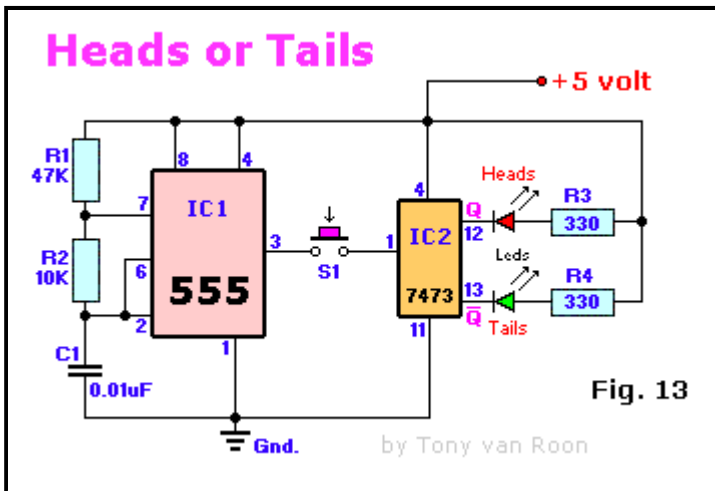

Circuits 11 to 14:

Play with different indicating devices such as bells, horns, lights, relays, or whatever (if possible). Try different types of LDR's. If for any reason you get false triggering, connect a ceramic 0.01uF (=10nF) capacitor between pin 5 (555) and ground. In all circuit diagrams below I used the LM555CN timer IC from National. Keeping notes is an important aspect of the learning process.

Fig. 11, Two-Tones: The purpose of this experiment is to wire two 555 timers together to create a 2-note tone. If you wish, you can use the dual 556 timer ic.

Fig. 12, Recording Beep: This circuit is used to keep recording of telephone conversations legal. As you may know, doing otherwise without consent of the other party is illegal. The output of IC1 is fed to the 2nd 555's pin 3 and made audible via C2 and the speaker. Any 8-ohm speaker will do.

Fig. 13, Coin Toss: Electronic 'Heads-or-tails' coin toss circuit. Basically a **Yes** or **No** decision maker when you can't make up your mind yourself. The 555 is wired as a Astable Oscillator, driving in turn, via pin 3, the **7473** flip-flop. When you press S1 it randomly selects the 'Heads' or 'Tails' led. The leds flashrate is about 2Khz (kilo-Hertz), which is much faster than your eyes can follow, so initially it appears that both leds are 'ON'. As soon as the switch is released only one led will be lit.

Fig. 14, Logic Probe: Provides you with three visible indicators; "Logic 1" (+, red led), "Logic 0" (-, green led), and "Pulse" (yellow led). Good for TTL and CMOS. The yellow or 'pulse' led comes on for approximately 200 mSec to indicate a pulse without regards to its width. This feature enables one to observe a short-duration pulse that would otherwise not be seen on the logic 1 and 0 led's. A small switch (subminiature slide or momentary push) across the 20K resistor can be used to keep this "pulse" led on permanently after a pulse occurs.

In operation, for a logic 0 input signal, both the '0' led and the pulse led will come 'ON', but the 'pulse' led will go off after 200 mSec. The logic levels are detected via resistor R1 (1K), then amplified by T1 (NPN, Si-AF Pre-amplifier/Driver), and selected by the 7400 IC for what they are. Diode D1 is a small signal diode to protect the **7400** and the leds from excessive inverse voltages during capacitor discharge.

For a logic '1' input, only the logic '1' led (red) will be 'ON'. With the switch closed, the circuit will indicate whether a negative-going or positive-going pulse has occurred. If the pulse is positive-going, both the '0' and 'pulse' led's will be on. If the pulse is negative-going, the '1' and 'pulse' led's will be on.

INPUTS			OUTPUTS	
Pin 4 (LOW)	Pin 6 (HIGH)	Pin 2 (LOW)	National LM555H	Signetics NE555V
	0	1	Resets	Resets
	1	1	0	0
	0	0		
	1	0	0	
1		1	Resets	Resets
1		0		1
0		1	0	0
0		0	0	0
1	0		sets	sets
1	1		0	
0	0		0	0
0	1		0	0

Pin 2 = Trigger, Pin 4 = Reset, Pin 6 = Threshold
Pin 2, 4, and 6 are 'active'

Table 2.

Check the listing in Table 2. It shows some variations in the 555 manufacturing process by two different manufacturers, National Semiconductor and Signetics Corporation. Since there are other manufacturers then those two I suggest when you build a circuit to stick with the particular 555 model they specify in the schematic. Unless you know what you're doing ofcourse... [grin].

The absolute **maximum** ratings (in free air) for NE/SA/SE types are:

	V _{cc} , supply voltage:	18V
Input voltage (CONT, RESET, THRES, TRIG):	V _{cc}	
	Output current:	225mA (approx)
Operating free-air temp. range:	NE555.....	0°C - 70°C
	SA555.....	-40°C - 85°C
	SE555, SE555C...	-55°C - 125°C
	Storage temperature range:	-65°C - 150°C
Case temperature for 60sec. (FK package):		260°C

Suggested Reading:

1. 555 Timer IC Circuits. Forrest M. Mims III, Engineer's Mini Notebook. Radio Shack Cat. No: 62-5010.
"Create & experiment with pulse generators, oscillators, and time delays."

2. IC Timer Cookbook. Walter G. Jung. Published by Howard W. Sams & Co., Inc. ISBN: 0-672-21932-8.
"A reference 'must' for hobby, technicians, and engineers."

3. The 555 Timer Applications Sourcebook. Howard M. Berlin. Published by Sams Inc. ISBN: 0-672-21538-1.
"Learn how to connect the 555, perform 17 simple experiments."

Copyright © 1996 - 2000 by Tony van Roon

Docs updated, [September 29, 2000](#)