

DC/DC converter for CD/DVD-ROM slim

BH6559FV

BH6559FV is an IC that incorporates 1 channel variable DC/DC converter and reset function. Variable DC/DC converter can set high-precision voltage ($\pm 2\%$ precision) by trimming reference voltage.

●Applications

CD/DVD-ROM slim

●Features

- 1) Low current consumption by adopting synchronous rectifier type.
- 2) Few external components reduced by the built-in power MOS transistor.
- 3) Adjustable by external resistor of DC/DC converter output.
- 4) Built-in reset for supply voltage and ATAPI (output pin is common).
- 5) Built-in delay time setting function for supply voltage reset.

●External dimensions (Units : mm)

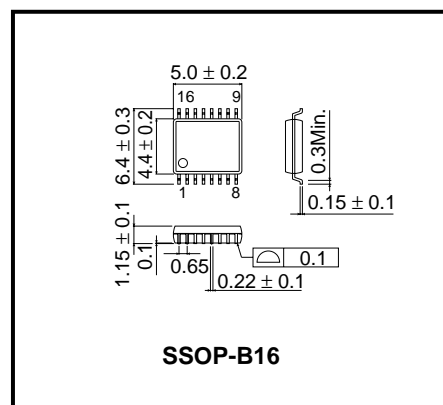

●Absolute maximum ratings (Ta=25°C)

Parameter	Symbol	Limits	Unit
Supply voltage 1 (PRE block)	PREV _{cc1}	7	V
Supply voltage 2 (PRE block)	PREV _{cc2}	7	V
Supply voltage (PRE block)	POWV _{cc}	7	V
Pin output current (DSW block)	I _{swomax}	1 *1	A
Power dissipation	P _d	0.56 *2	W
Operating temperature range	T _{opr}	-30 to +85	°C
Storage temperature range	T _{stg}	-55 to +150	°C

*1 Intermittent current at maximum applied time of 5msec, 1/10 duty (Max.)

*2 Derating : 4.5mW/°C for operation above Ta=25°C. On less than 3% (percentage occupied by copper foil), 70mm×70mm, t=1.6mm, glass epoxy mounting.

Optical discs

●Recommended Operating Conditions (Ta=25°C)

Parameter	Symbol	Min.	Typ.	Max.	Unit
Supply voltage 1 (PRE block)	PREV _{CC1}	4.5	5.0	5.5	V
Supply voltage 2 (PRE block)	PREV _{CC2}	4.5	5.0	5.5	V
Supply voltage (Pow block)	POWV _{CC}	4.5	5.0	5.5	V
Ambient temperature	Ta	-10	25	70	°C
Vatiable DC/DC converter output current *	I _o	-	300	500	mA
Vatiable DC/DC converter output voltage	V _{BD}	1.7	-	V _{CC} -1	V

* When L=47μH, C=47μF is used

●Electrical characteristics (Ta=25°C, PREV_{CC1}/2=5V, POWV_{CC}=5V)

Parameter	Symbol	Min.	Typ.	Max.	Unit	Conditions
Current consumption at no signal	I _{CC}	-	1.2	24	mA	No load
< Variable DC/DC converter >						
EI pin threshold voltage	VEITH	0.980	1.00	1.020	V	
DSW pin ON resistance H	RDSWONH	-	0.42	0.87	Ω	IL=500mA
DSW pin ON resistance L	RDSWONL	-	0.30	0.60	Ω	IL=-500mA
DSW pin oscillation frequency	f _{DSW}	210	310	410	kHz	OSC_R=22kΩ
< Reset block >						
Vcc reset ON voltage	VRSTON	3.52	3.70	3.88	V	sweep down
Vcc reset hysteresis width	VRSTHYS	50	80	110	mV	
Vcc reset delay time	VRSTT	30	50	70	msec	RESET τ=0.1μF
ATAPI reset ON voltage	VATPON	1.25	1.40	1.55	V	sweep down
ATAPI reset hysteresis width	VATPHYS	40	60	90	mV	

* This product is not designed for protection against radioactive rays.

●Application Circuit

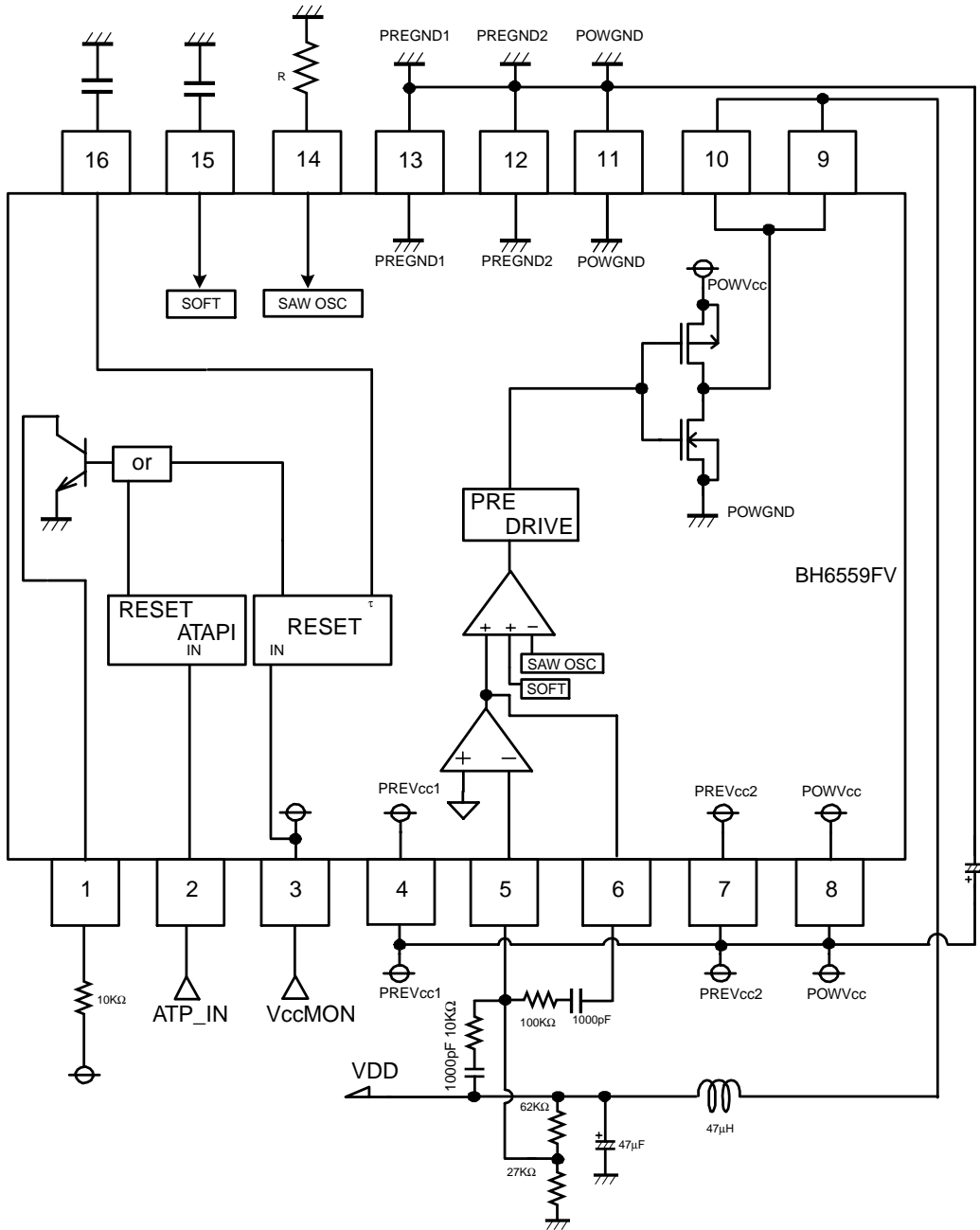

Notes

- No technical content pages of this document may be reproduced in any form or transmitted by any means without prior permission of ROHM CO.,LTD.
- The contents described herein are subject to change without notice. The specifications for the product described in this document are for reference only. Upon actual use, therefore, please request that specifications to be separately delivered.
- Application circuit diagrams and circuit constants contained herein are shown as examples of standard use and operation. Please pay careful attention to the peripheral conditions when designing circuits and deciding upon circuit constants in the set.
- Any data, including, but not limited to application circuit diagrams information, described herein are intended only as illustrations of such devices and not as the specifications for such devices. ROHM CO.,LTD. disclaims any warranty that any use of such devices shall be free from infringement of any third party's intellectual property rights or other proprietary rights, and further, assumes no liability of whatsoever nature in the event of any such infringement, or arising from or connected with or related to the use of such devices.
- Upon the sale of any such devices, other than for buyer's right to use such devices itself, resell or otherwise dispose of the same, no express or implied right or license to practice or commercially exploit any intellectual property rights or other proprietary rights owned or controlled by
- ROHM CO., LTD. is granted to any such buyer.
- Products listed in this document use silicon as a basic material.
Products listed in this document are no antiradiation design.

The products listed in this document are designed to be used with ordinary electronic equipment or devices (such as audio visual equipment, office-automation equipment, communications devices, electrical appliances and electronic toys).

Should you intend to use these products with equipment or devices which require an extremely high level of reliability and the malfunction of which would directly endanger human life (such as medical instruments, transportation equipment, aerospace machinery, nuclear-reactor controllers, fuel controllers and other safety devices), please be sure to consult with our sales representative in advance.

About Export Control Order in Japan

Products described herein are the objects of controlled goods in Annex 1 (Item 16) of Export Trade Control Order in Japan.

In case of export from Japan, please confirm if it applies to "objective" criteria or an "informed" (by MITI clause) on the basis of "catch all controls for Non-Proliferation of Weapons of Mass Destruction.