

Features

- 4 channels of DC motor BTL driver
- 1 channels forward/reverse control DC motor driver
- Built-in suspension function.
- Built-in 1-channel OPA.
- Built-in 1-Channel Comparator.
- Built-in thermal shutdown circuit.
- Operating voltage: 4.5V~13.2V

Description

The AT5668 is a 5-channel BTL driver IC. Two of them can drive DC motors and two can drive coils, such as the focus and tracking actuators of a CD-ROM/DVD-ROM/DVD-Player system, with current feedback. It also built-in one channel bi-direction DC motor driver for Tray.

Applications

CD-ROM/DVD-ROM/CD-RW drives
DVD player.

Block Diagram

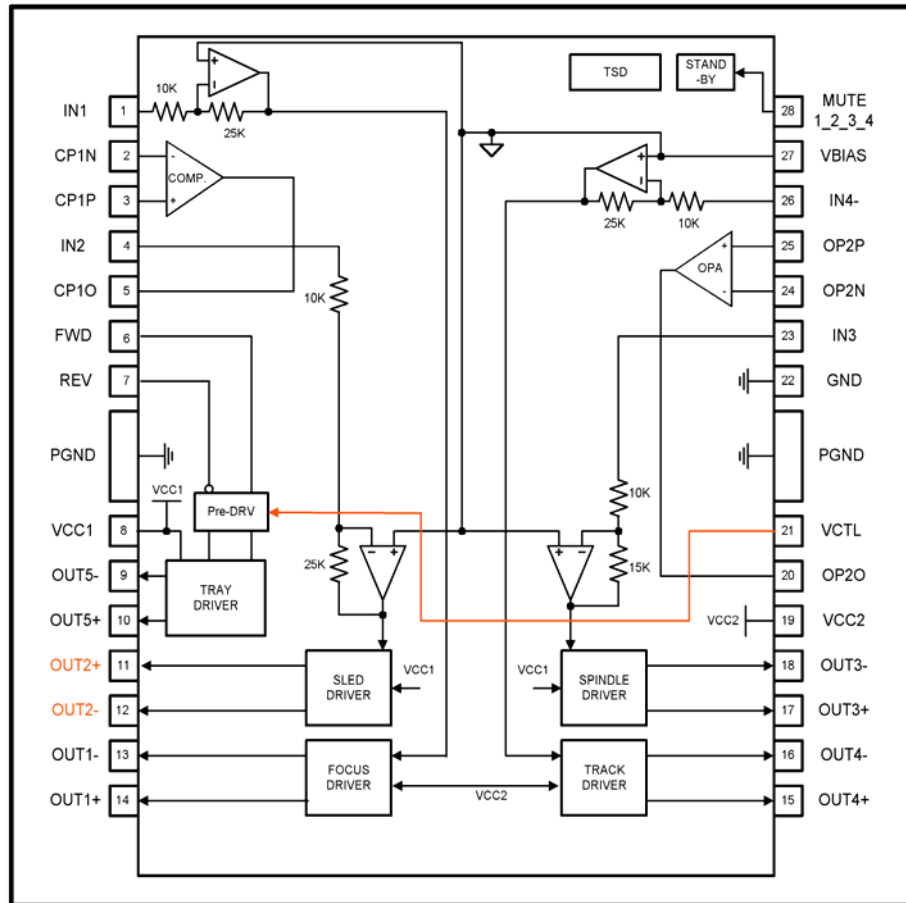

Aimtron reserves the right without notice to change this circuitry and specifications.

Pin Descriptions

Pin No.	Pin name	Function
1	IN1	CH1(Focus coil) input
2	CP1N	Comparator negative input
3	CP1P	Comparator positive input
4	IN2	CH2(Sled driver) input
5	CP1O	Comparator Output
6	FWD	CH5 forward input
7	REV	CH5 reverse input
8	VCC1	Power Supply 1
9	OUT5-	CH5(Tray driver) output(-)
10	OUT5+	CH5(Tray driver) output(+)
11	OUT2+	CH2(Sled driver) output (+)
12	OUT2-	CH2(Sled driver) output (-)
13	OUT1-	CH1(Focus coil) output (-)
14	OUT1+	CH1(Focus coil) output (+)
15	OUT4+	CH4(Tracking coil) output (+)
16	OUT4-	CH4(Tracking coil) output (-)
17	OUT3+	CH3(Loader) output (+)
18	OUT3-	CH3(Loader) output (-)
19	VCC2	Power Supply 2
20	OP2O	Error amplifier output
21	VCTL	CH5 Speed control input
22	GND	Ground
23	IN3	CH3(Loader) input
24	OP2N	Error amplifier negative input
25	OP2P	Error amplifier positive input
26	IN4-	CH4 (Tracking driver) input
27	VBIAS	VREF input pin
28	MUTE 1 2 3 4	Mute control for CH1,CH2,CH3,CH4

Pin Out

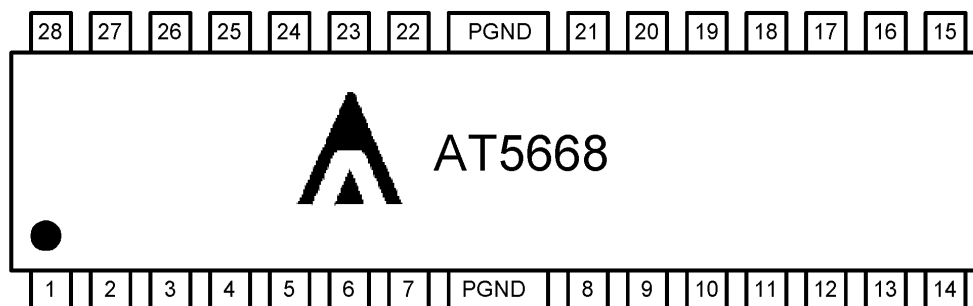

Ordering Information

Part number	Package	Marking
AT5668H	28-pin HSOP	AT5668H

Power Dissipation (Ta = 25°C)

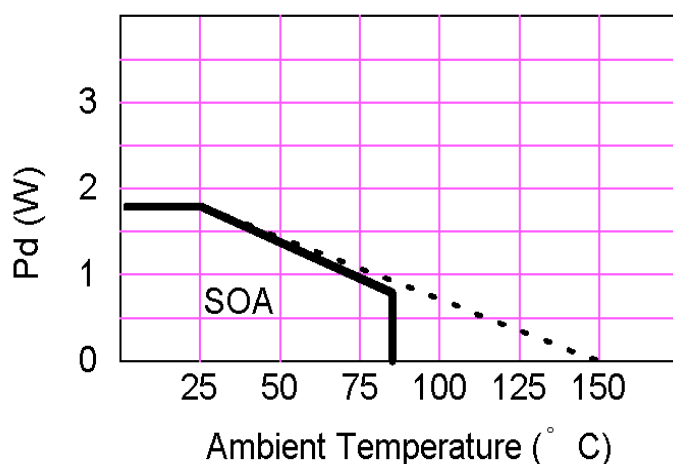

Condition: mount on 50x50 mm² t=1.0mm paper phenol PCB

Absolute maximum ratings (Ta = 25°C)

Parameter	Symbol	Limits	unit
Power supply voltage	VCC1,2	13.5	V
Power dissipation	P _d	1.7	W
Operating temperature	T _{opr}	-30~+80	°C
Storage temperature	T _{stg}	-55~+150	°C

NOTE:*

1. Power dissipation reduces 13.6mW / °C for using above Ta=25°C
2. Do not exceed Pd and SOA.

Recommended operating conditions (Ta = 25°C)

Parameter	Symbol	Limits	unit
Power supply voltage	VCC1	4.0~13.2	V
	VCC2	4.0~Vcc1	V

Electrical characteristics

(unless otherwise noted, $T_a = 25^\circ\text{C}$, $V_{CC1} = 12\text{V}$, $V_{CC2} = 5\text{V}$, $V_{BIAS} = 2.5\text{V}$, $R_{L1} = R_{L4} = 8\Omega$, $R_{L2} = R_{L3} = 12\Omega$)

Parameter	Symbol	Min.	Typ.	Max.	Unit	Conditions
Quiescent current	I_{OC}	-	18	30	mA	No Load
Mute quiescent current	I_{OSB}	-	-	5	mA	CH5 ,OPA,COMP. active
Mute ON voltage	V_{SBON}	0	-	0.5	V	
Mute OFF voltage	V_{SBOFF}	2.0	-	-	V	
<Track driver>						
Output voltage offset	V_{OFFSL}	-100	0	100	mV	
Maximum output voltage	V_{O3MAX}	3.6	4.0	-	V	$V_{IN} = V_{BIAS} \pm 1.5\text{V}$
Closed loop gain	G_{VSL}	18.0	20.0	22.0	dB	$V_{IN} = V_{BIAS} \pm 0.2\text{V}$
<Focus driver>						
Output voltage offset	V_{OFFSL}	-100	0	100	mV	
Maximum output voltage	V_{O3MAX}	3.6	4.0	-	V	$V_{IN} = V_{BIAS} \pm 1.5\text{V}$
Closed loop gain	G_{VSL}	18.0	20.0	22.0	dB	$V_{IN} = V_{BIAS} \pm 0.2\text{V}$
<Sled motor driver>						
Output voltage offset	V_{OFFSL}	-100	0	100	mV	
Maximum output voltage	V_{O3MAX}	7.5	9.0	-	V	$V_{IN} = V_{BIAS} \pm 1.5\text{V}$
Closed loop gain	G_{VSL}	18.0	20.0	22.0	dB	$V_{IN} = V_{BIAS} \pm 0.2\text{V}$
<Spindle motor driver>						
Output voltage offset	V_{OFFLD}	-100	0	100	mV	
Maximum output voltage	V_{O4max1}	7.5	9.0	-	V	$V_{IN} = V_{BIAS} \pm 2.0\text{V}$
Maximum output voltage	V_{O4max2}	3.6	4.0	-	V	$V_{IN} = V_{BIAS} \pm 1.5\text{V}$ $V_{CC1} = 5\text{V}$
Closed loop gain	G_{VLD}	13.5	15.5	17.5	dB	$V_{IN} = V_{BIAS} \pm 0.2\text{V}$
Gain error	ΔG_{VLD}	0	1	2	dB	$V_{IN} = V_{BIAS} \pm 0.2\text{V}$
<Tray motor driver>						
Maximum output voltage	V_{O5max1}	3.8	-	4.2	V	$R_{L5} = 45\Omega$, $R_{VCTL} = 0\Omega$, $V_{CC1} = V_{CC2} = 5\text{V}$
Output voltage offset	V_{OFFTR}	-100	0	100	mV	
Input high level voltage	V_{IH}	2.0	-	-	V	
Input low level voltage	V_{IL}	-	-	0.8	V	
<OPA>						
Input Dynamic Range		0	-	$V_{CC1} - 1.5\text{V}$	V	
Output Dynamic Range	V_O	1	-	$V_{CC1} - 1.0\text{V}$	V	$I_O = -0.25\text{mA} \sim 3\text{mA}$
Voltage Gain	G_{VC}	70	-	90	dB	
Saturation Voltage	V_S	-	0.25	0.4	V	$I_O = 3\text{mA}$
Input Offset	V_{Offset}	-	-	± 10	mV	
<Comparator>						
Input Offset	V_{Offset}	-	-	± 10	mV	
Input Dynamic Range		0	-	$V_{CC1} - 1.5\text{V}$	V	
Output Dynamic Range	V_O	0.25	-	$V_{CC1} - 1.0\text{V}$	V	$I_O = -0.25\text{mA} \sim 3\text{mA}$
Saturation Voltage	V_S	-	0.25	0.4	V	$I_O = 4\text{mA}$

Tray Motor Driver

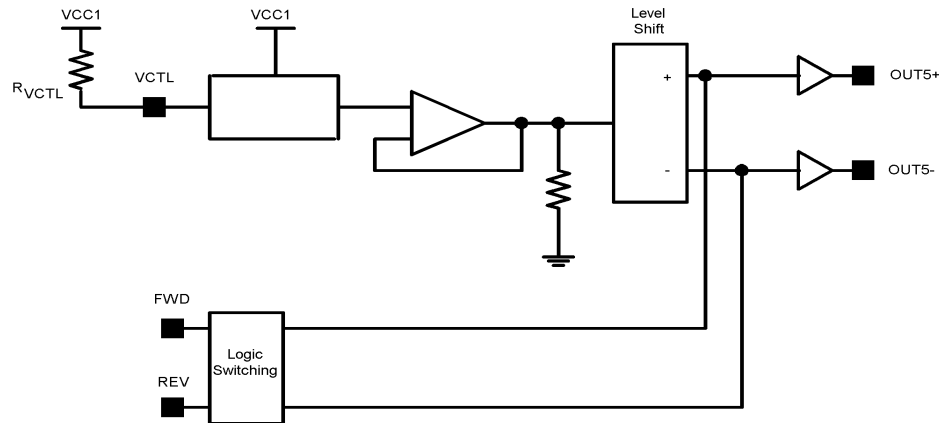

Fig1.

Input		Output		
FWD	REV	OUT5+	OUT5-	Status
High	High	Low	Low	Break
High	Low	High	Low	Forward
Low	High	Low	High	Reverse
Low	Low	Open	Open	Standby

Tray Motor Speed Control

The amplitude of the output voltage is controlled by VCTL(pin21). If you want to control differential output voltage of the tray, insert external resistor R_{VCTL} as shown in figure 1.

Test Circuit

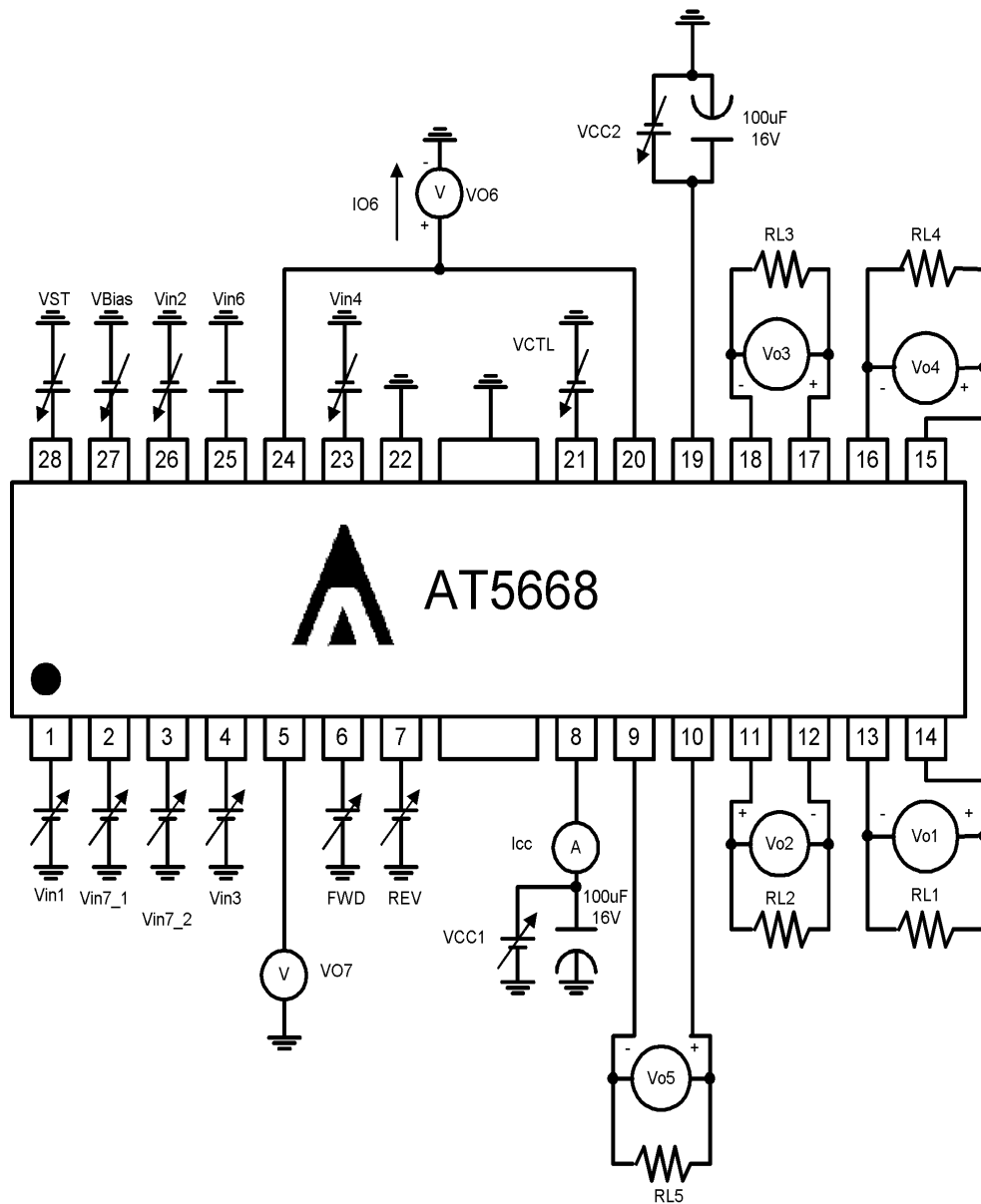

Typical Curve

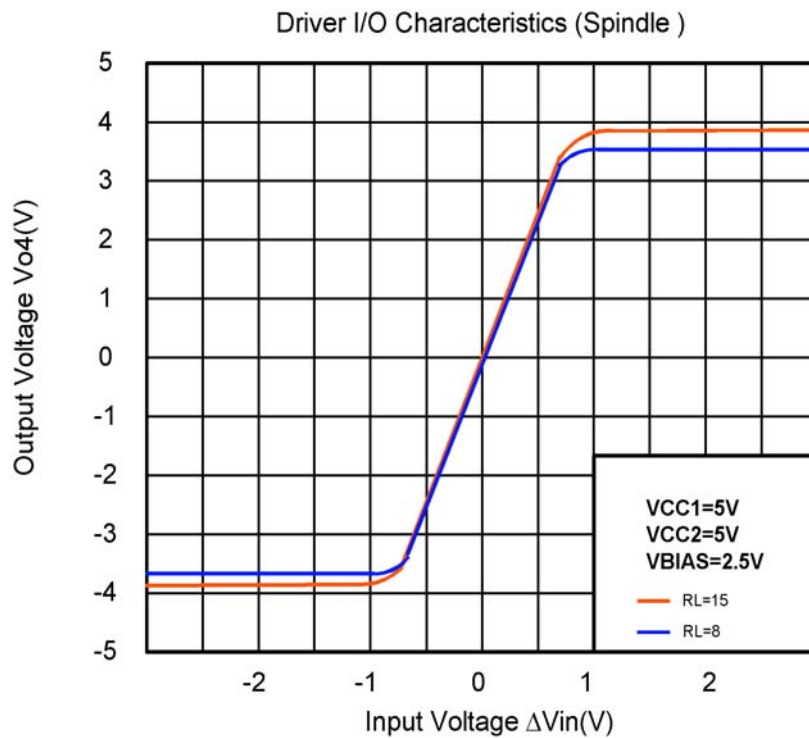
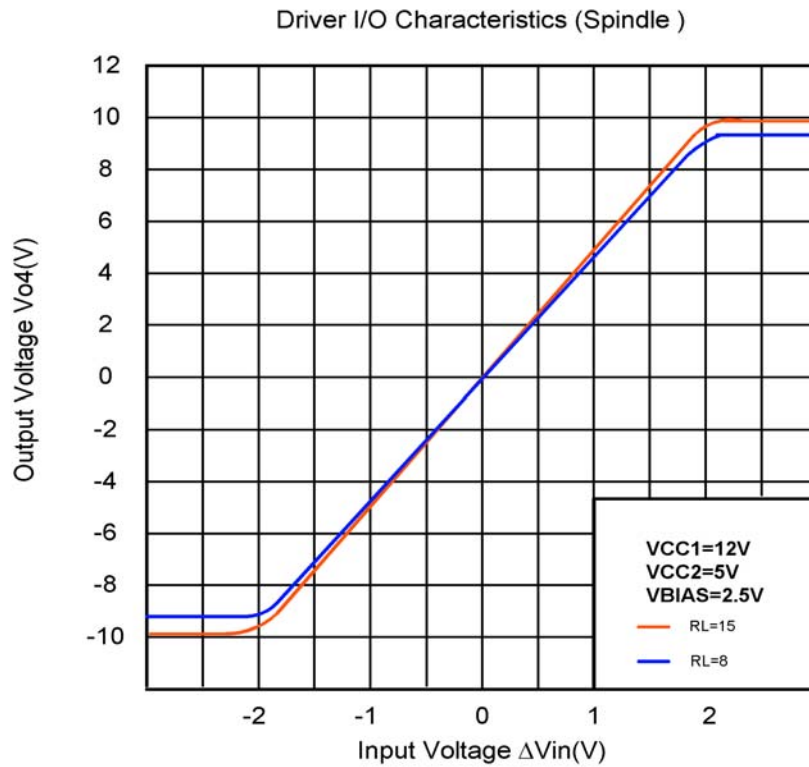

Driver I/O Characteristics (Sled ,Track,Focus)

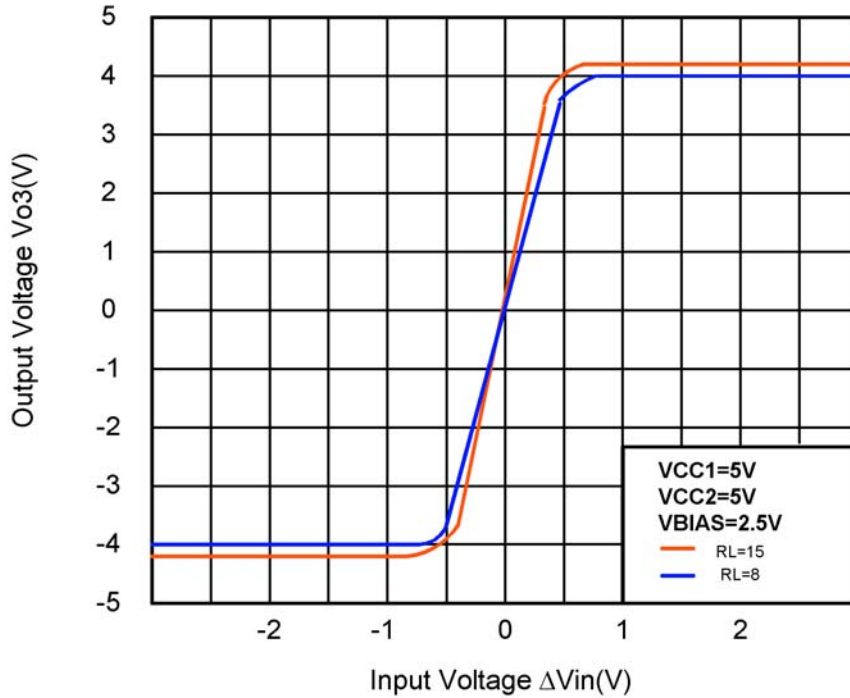

Driver I/O Characteristics (Sled)

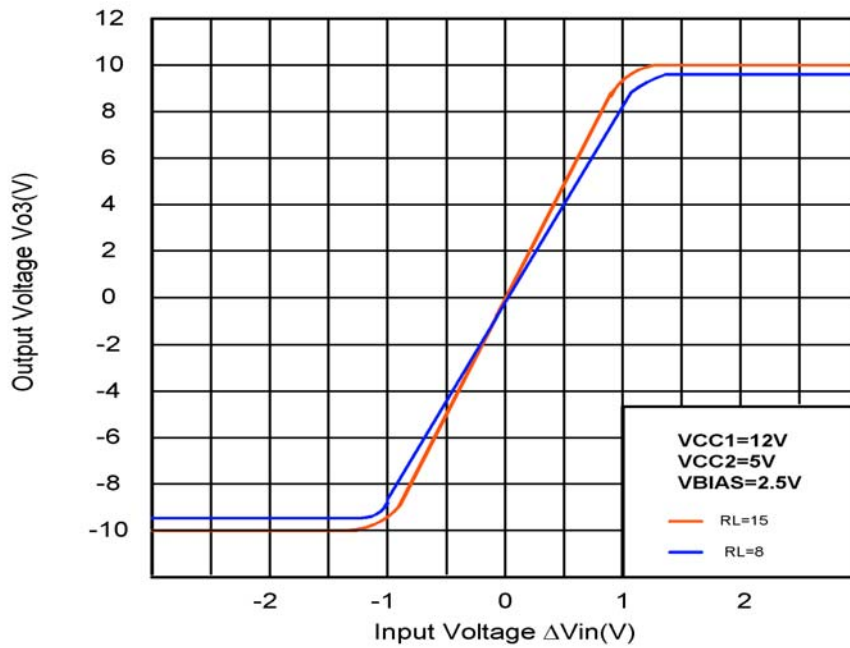

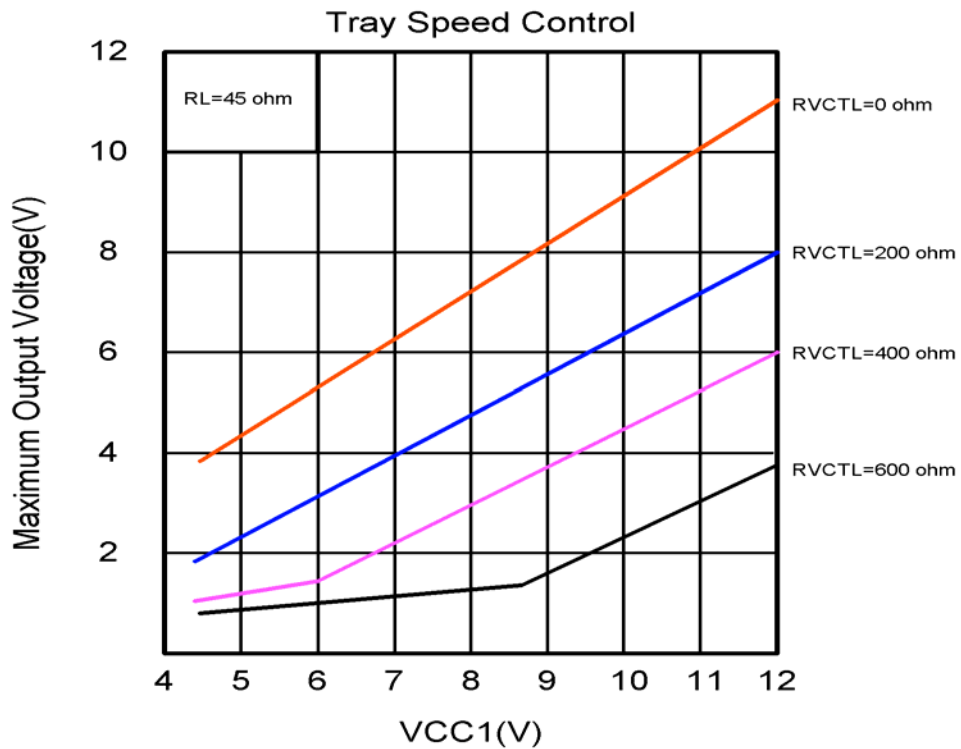
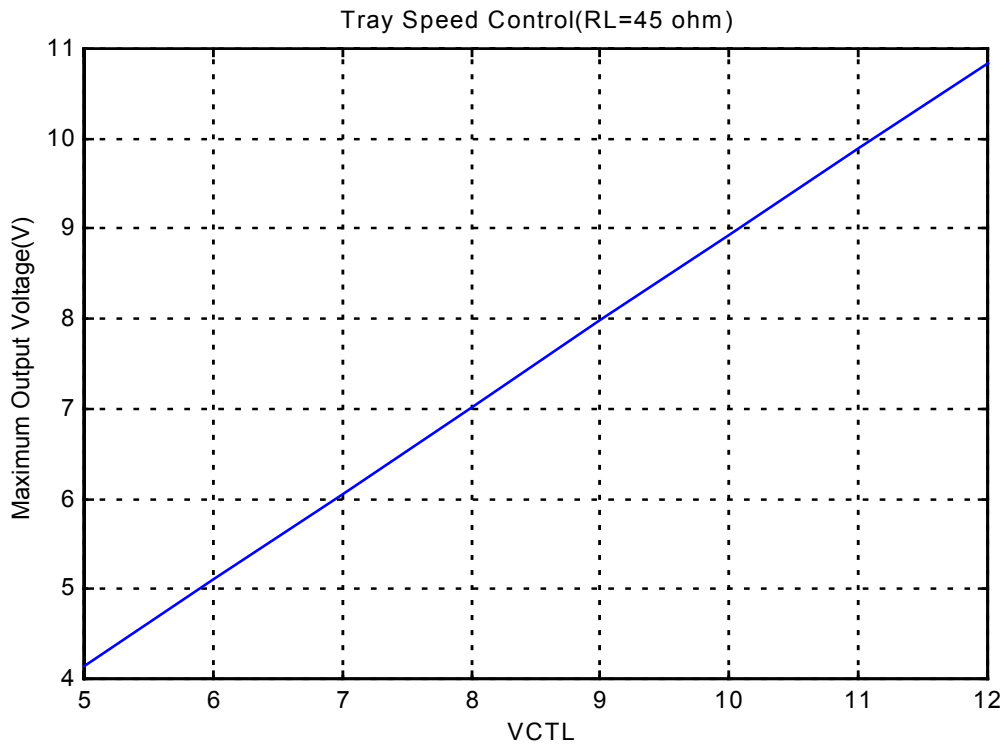

Application circuit

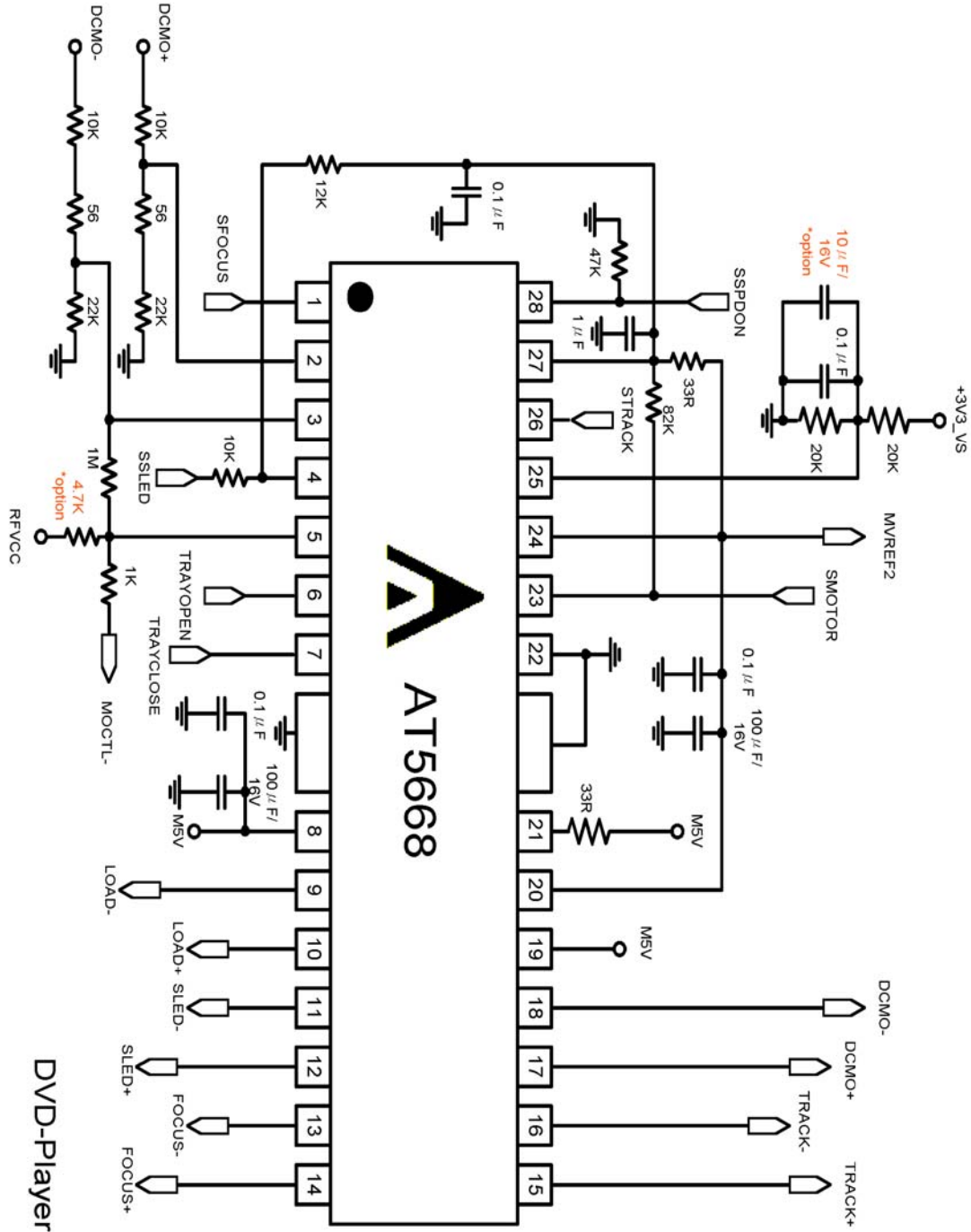

Package Outlines (units:mm): HSOP-28

