

**VICOR CONFIDENTIAL**

THIS DOCUMENT AND THE DATA DISCLOSED  
HEREIN OR HEREWITH IS NOT TO BE REPRODUCED,  
USED, OR DISCLOSED IN WHOLE OR IN PART  
TO ANYONE WITHOUT PERMISSION OF VICOR CORP.

REV.	DESCRIPTION	DATE	APPROVED
6	RELEASED PER ECO #E910657 CFH	11/25/91	[Signature]

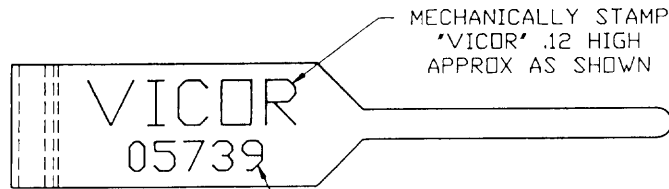
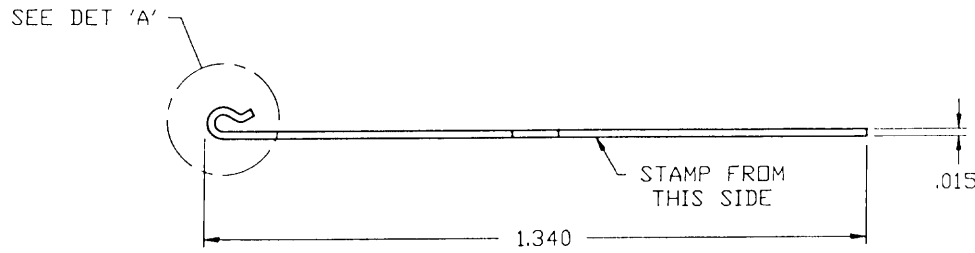
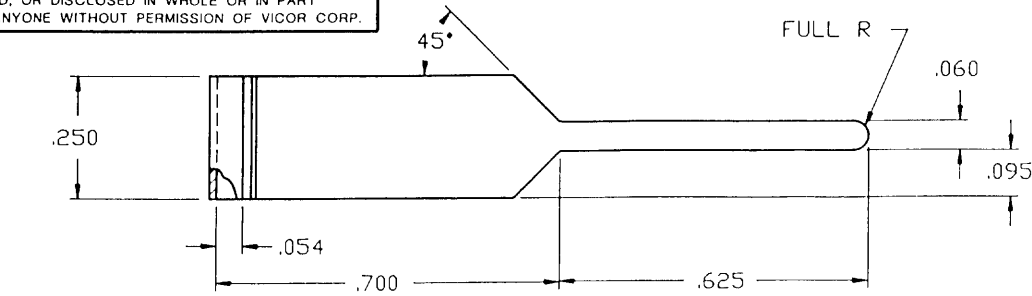

MECHANICALLY STAMP  
'05739' .06 HIGH  
APPROX AS SHOWN

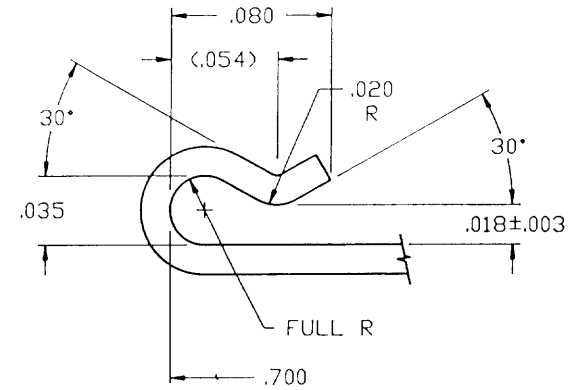

DETAIL 'A'  
SCALE 16X

NOTES

1. MATERIAL: 260 BRASS .015 THK, HALF HARD.
2. FINISH: COPPER STRIKE AND SOLDER PLATE TO 100-300 μIN THICKNESS.

UNLESS OTHERWISE SPECIFIED  
DIMENSIONS ARE IN INCHES  
TOLERANCES ARE:

FRACTIONS	DECIMALS	ANGLES
± 1/64	.XX ± .01	± 1°
	.XXX ± .005	

THIRD ANGLE PROJECTION

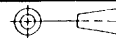

DO NOT SCALE DRAWING

APPROVALS DATE

DRAWN: C HUTCHINS 4 /91

CHECKED:

ISSUED

APPROVED



GROUNDING CLIP,  
MODULE

SIZE	FSCM NO.	DWG. NO.	REV.
B	67131	05739	6
SCALE 4X		SHEET 1 OF 1	