

CMOS 8-Bit Microcontroller

**TMP87PH00N**  
**TMP87PH00F**  
**TMP87PH00DF**  
**TMP87PH00LF**

The 87PH00 is a One-Time PROM microcontroller with low-power 128 K bits (16 Kbytes) electrically programmable read only memory for the 87C800/CH00 system evaluation. The 87PH00 is pin compatible with the 87C800/CH00. The operations possible with the 87C800/CH00 can be performed by writing programs to PROM. The 87PH00 can write and verify in the same way as the TMM27256AD using an adaptor socket BM1136/BM1137/BM1173 and an EPROM programmer.

Part No.	OTP	RAM	Package	Adapter Socket
TMP87PH00N	16 K × 8-bit	256 × 8-bit	P-SDIP64-750-1.78	BM1136
TMP87PH00F			P-QFP64-1420-1.00A	BM1137
TMP87PH00DF			P-QFP64-1414-0.80A	BM1173
TMP87PH00LF				

Pin Assignments (Top View)

P-SDIP64-750-1.78

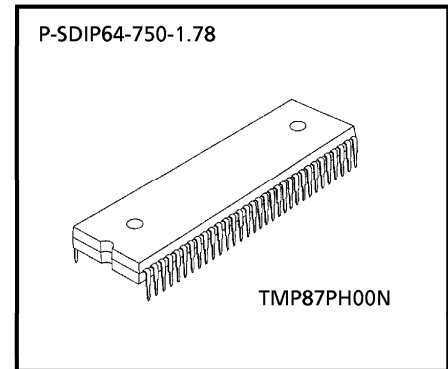
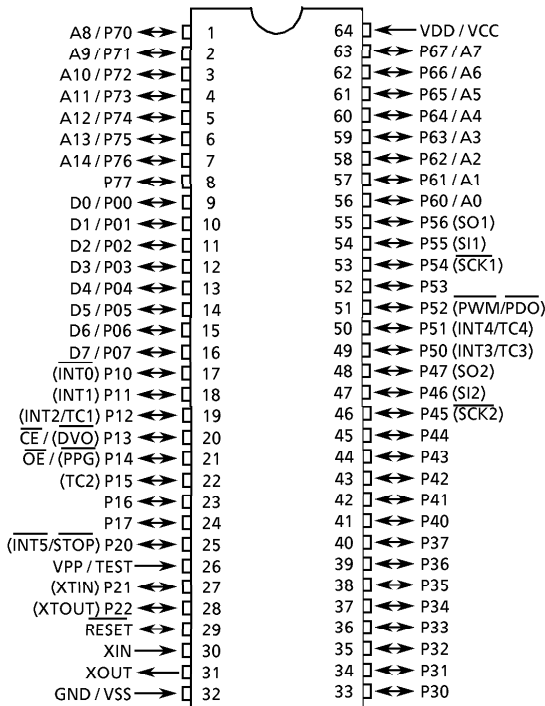

980910EBP2

- For a discussion of how the reliability of microcontrollers can be predicted, please refer to Section 1.3 of the chapter entitled Quality and Reliability Assurance / Handling Precautions.
- TOSHIBA is continually working to improve the quality and the reliability of its products. Nevertheless, semiconductor devices in general can malfunction or fail due to their inherent electrical sensitivity and vulnerability to physical stress. It is the responsibility of the buyer, when utilizing TOSHIBA products, to observe standards of safety, and to avoid situations in which a malfunction or failure of a TOSHIBA product could cause loss of human life, bodily injury or damage to property. In developing your designs, please ensure that TOSHIBA products are used within specified operating ranges as set forth in the most recent products specifications. Also, please keep in mind the precautions and conditions set forth in the TOSHIBA Semiconductor Reliability Handbook.
- The products described in this document are subject to the foreign exchange and foreign trade laws.
- The information contained herein is presented only as a guide for the applications of our products. No responsibility is assumed by TOSHIBA CORPORATION for any infringements of intellectual property or other rights of the third parties which may result from its use. No license is granted by implication or otherwise under any intellectual property or other rights of TOSHIBA CORPORATION or others.
- The information contained herein is subject to change without notice.

Pin Assignments (Top View)

P-QFP64-1420-1.00A

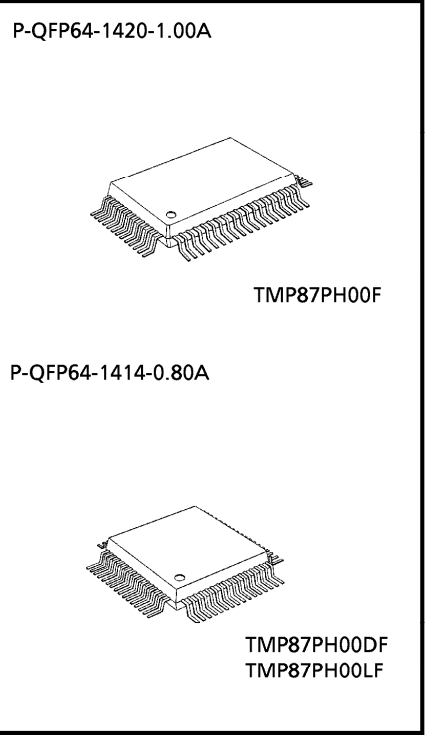
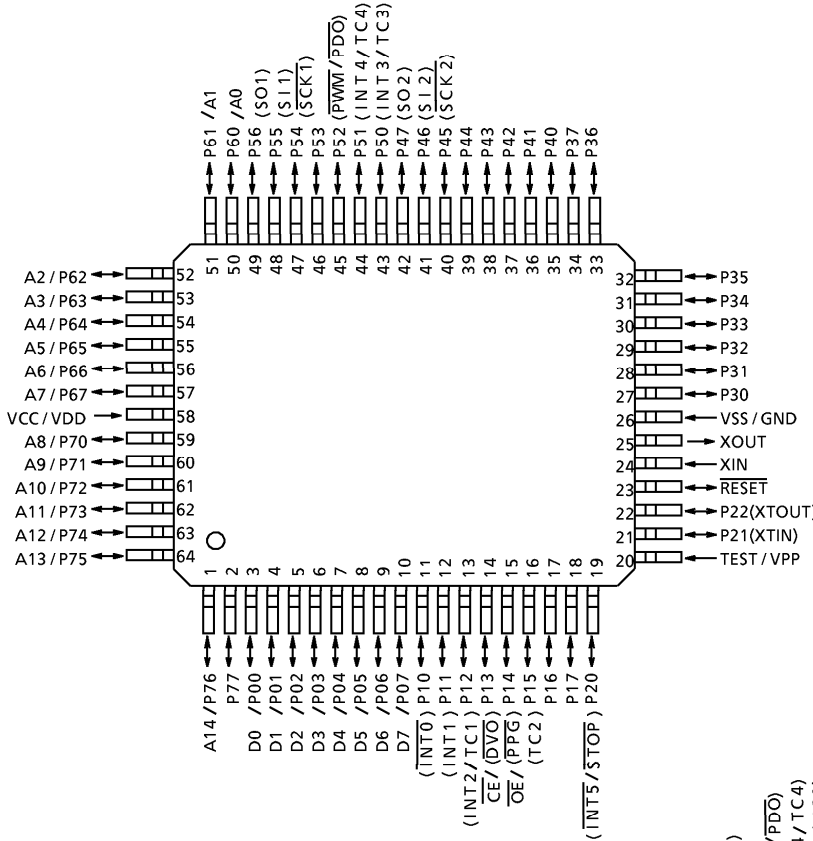

P-QFP64-1414-0.80A

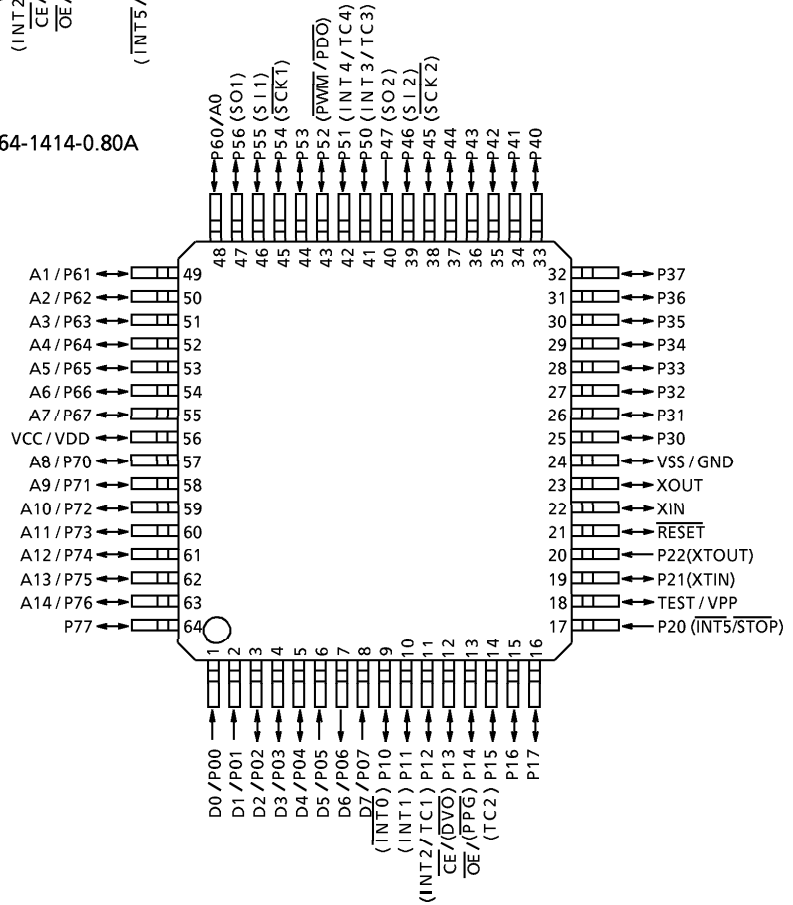

**Pin Function**

The 87PH00 has two modes: MCU and PROM.

(1) MCU mode

In this mode, the 87PH00 is pin compatible with the 87C800/CH00 (fix the TEST pin at low level).

(2) PROM mode

Pin Name (PROM mode)	Input/Output	Functions	Pin Name (MCU mode)
A14 to A8	Input	PROM address inputs	P76 to P70
A7 to A0			P67 to P60
D7 to D0	I/O	PROM data input/outputs	P07 to P00
$\overline{CE}$	Input	Chip enable signal input (active low)	P13
$\overline{OE}$		Output enable signal input (active low)	P14
VPP	Power supply	+ 12.5 V / 5 V (Program supply voltage)	TEST
VCC		+ 5 V	VDD
GND		0 V	VSS
P37 to P30	I/O	Pull-up with resistance for input processing	
P47 to P40			
P56 to P50			
P11		PROM mode setting pin. Be fixed at high level.	
P21			
P77			
P17 to P15		PROM mode setting pin. Be fixed at low level.	
P12, P10			
P22, P20			
$\overline{RESET}$			
XIN	Input	Connect an 8MHz oscillator to stabilize the internal state.	
XOUT	Output		

### Operational Description

The following explains the 87PH00 hardware configuration and operation. The configuration and functions of the 87PH00 are the same as those of the 87C800/CH00, except in that a one-time PROM is used instead of an on-chip mask ROM.

The 87PH00 is placed in the *single-clock* mode during reset. To use the dual-clock mode, the low-frequency oscillator should be turned on by executing [SET (SYSCR2). XTEN] instruction at the beginning of the program.

### 1. Operating Mode

The 87PH00 has two modes: MCU and PROM.

#### 1.1 MCU mode

The MCU mode is activated by fixing the TEST / VPP pin at low level.

In the MCU mode, operation is the same as with the 87C800/CH00 (the TEST / VPP pin cannot be used open because it has no built-in pull-down resistance).

#### 1.1.1 Program Memory

The 87PH00 has a 16 K × 8-bit (addresses C000<sub>H</sub> to FFFF<sub>H</sub> in the MCU mode, addresses 4000<sub>H</sub> to 7FFF<sub>H</sub> in the PROM mode) of program memory (OTP).

To use the 87PH00/PH00L as the system evaluation for the 87C800/CH00/CH00L, the program should be written to the program memory area as shown in Figure 1-1.

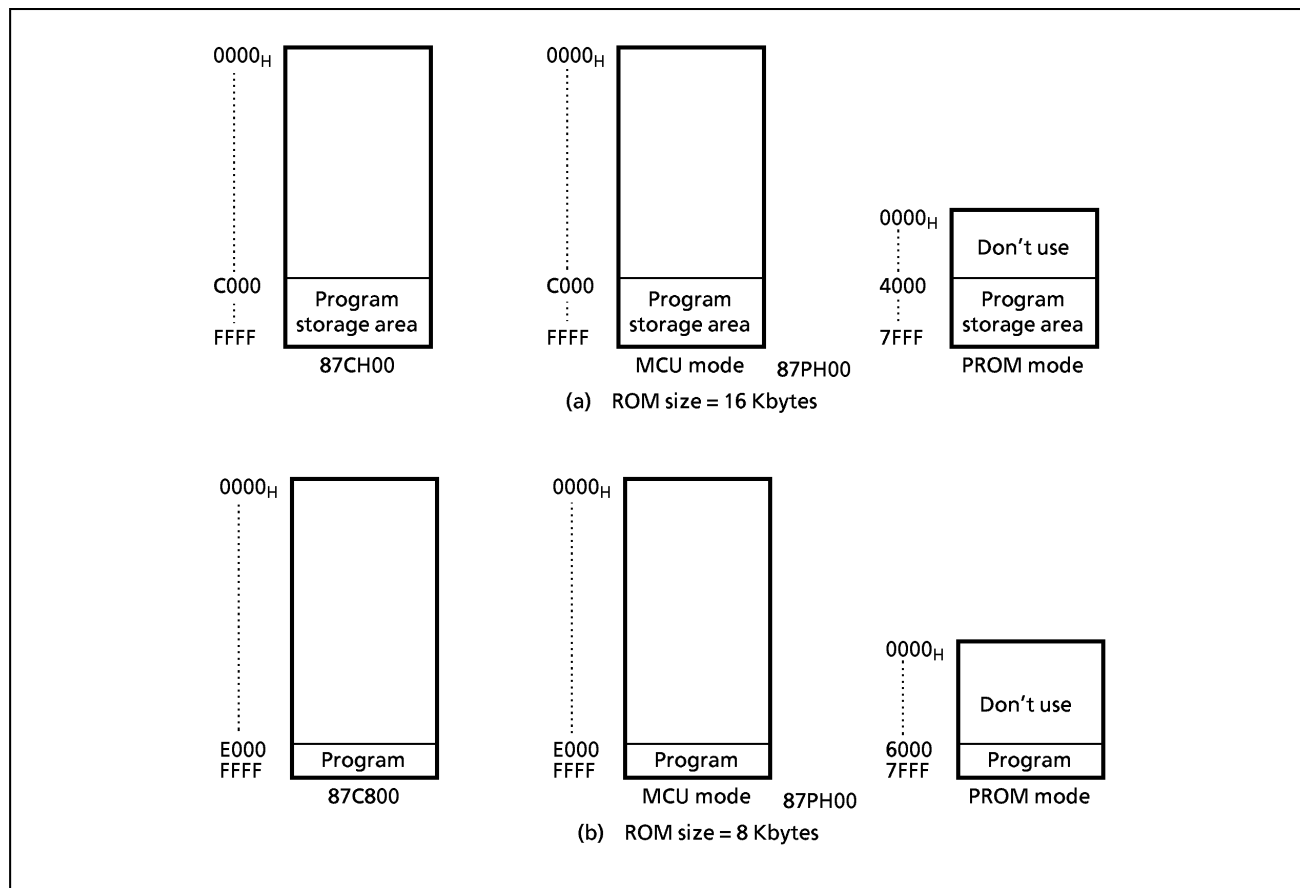

Figure 1-1. Program Memory Area

**Note:** Either write the data FFH to the unused area or set the PROM programmer to access only the program storage area.

## Electrical Characteristics

## Absolute Maximum Ratings

 $(V_{SS} = 0 \text{ V})$ 

Parameter	Symbol	Conditions	Ratings	Unit
Supply Voltage	$V_{DD}$		- 0.3 to 7	V
Program Voltage	$V_{PP}$	TEST / VPP	- 0.3 to 13.0	V
Input Voltage	$V_{IN}$		- 0.3 to $V_{DD} + 0.3$	V
Output Voltage	$V_{OUT1}$	P0, P1, P2, P6, P7, XOUT, $\overline{\text{RESET}}$	- 0.3 to $V_{DD} + 0.3$	V
	$V_{OUT2}$	P3, P4, P5	- 0.3 to 10	
Output Current (Per 1 pin)	$I_{OUT1}$	P0, P1, P2, P4, P5, P6, P7	3.2	mA
	$I_{OUT2}$	P3	30	
Output Current (Total)	$\Sigma I_{OUT1}$	P0, P1, P2, P4, P5, P6, P7	120	mA
	$\Sigma I_{OUT2}$	P3	120	
Power Dissipation [ $T_{opr} = 70^\circ\text{C}$ ]	PD	TMP87PH00N	600	mW
		TMP87PH00F / PH00DF	350	
Soldering Temperature (time)	$T_{sld}$		260 (10 s)	$^\circ\text{C}$
Storage Temperature	$T_{stg}$		- 55 to 125	$^\circ\text{C}$
Operating Temperature	$T_{opr}$		- 30 to 70	$^\circ\text{C}$

**Note:** The absolute maximum ratings are rated values which must not be exceeded during operation, even for an instant. Any one of the ratings must not be exceeded. If any absolute maximum rating is exceeded, a device may break down or its performance may be degraded, causing it to catch fire or explode resulting in injury to the user. Thus, when designing products which include this device, ensure that no absolute maximum rating value will ever be exceeded.

## Recommended Operating Conditions

 $(V_{SS} = 0 \text{ V}, T_{opr} = - 30 \text{ to } 70^\circ\text{C})$ 

Parameter	Symbol	Pins	Conditions	Min	Max	Unit	
Supply Voltage	$V_{DD}$		$f_c = 8 \text{ MHz}$	NORMAL1, 2 mode	4.5	6.0	V
				IDLE1, 2 mode			
			$f_c = 4.2 \text{ MHz}$	NORMAL1, 2 mode	2.7		
				IDLE1, 2 mode			
			$f_s = 32.768 \text{ kHz}$	SLOW mode	2.0		
				SLEEP mode			
STOP mode							
Input High Voltage	$V_{IH1}$	Except hysteresis input	$V_{DD} \geq 4.5 \text{ V}$	$V_{DD} \times 0.70$	$V_{DD}$	V	
	$V_{IH2}$	Hysteresis input		$V_{DD} \times 0.75$			
	$V_{IH3}$			$V_{DD} < 4.5 \text{ V}$			$V_{DD} \times 0.90$
Input Low Voltage	$V_{IL1}$	Except hysteresis input	$V_{DD} \geq 4.5 \text{ V}$	0	$V_{DD} \times 0.30$	V	
	$V_{IL2}$	Hysteresis input		$V_{DD} \times 0.25$			
	$V_{IL3}$			$V_{DD} < 4.5 \text{ V}$	$V_{DD} \times 0.10$		
Clock Frequency	$f_c$	XIN, XOUT	$V_{DD} = 4.5 \text{ to } 6 \text{ V}$	0.4	8.0	MHz	
			$V_{DD} = 2.7 \text{ to } 6 \text{ V}$		4.2		
	$f_s$	XTIN, XTOUT		30.0	34.0	kHz	

**Note 1:** The recommended operating conditions for a device are operating conditions under which it can be guaranteed that the device will operate as specified. If the device is used under operating conditions other than the recommended operating conditions (supply voltage, operating temperature range, specified AC/DC values etc.), malfunction may occur. Thus, when designing products which include this device, ensure that the recommended operating conditions for the device are always adhered to.

**Note 2:** Clock frequency  $f_c$ : Supply voltage range is specified in NORMAL mode and IDLE mode.

## D.C. Characteristics

 $(V_{SS} = 0\text{ V}, T_{opr} = -30\text{ to }70^\circ\text{C})$ 

Parameter	Symbol	Pins	Conditions	Min	Typ.	Max	Unit
Hysteresis Voltage	$V_{HS}$	Hysteresis inputs	$V_{DD} = 5.0\text{ V}$	–	0.9	–	V
Input Current	$I_{IN1}$	TEST	$V_{DD} = 5.5\text{ V}$ $V_{IN} = 5.5\text{ V} / 0\text{ V}$	–	–	$\pm 2$	$\mu\text{A}$
	$I_{IN2}$	Open drain ports, tri-state ports					
	$I_{IN3}$	$\overline{\text{RESET}}, \overline{\text{STOP}}$					
Input Resistance	$R_{IN2}$	$\overline{\text{RESET}}$	$V_{DD} = 5.0\text{ V}$	100	220	450	$\text{k}\Omega$
Output Leakage Current	$I_{LO1}$	Sink open drain ports	$V_{DD} = 5.5\text{ V}, V_{OUT} = 5.5\text{ V}$	–	–	2	$\mu\text{A}$
	$I_{LO2}$	Tri-state ports	$V_{DD} = 5.5\text{ V}, V_{OUT} = 5.5\text{ V} / 0\text{ V}$	–	–	$\pm 2$	
Output High Voltage	$V_{OH2}$	Tri-state ports	$V_{DD} = 4.5\text{ V}, I_{OH} = -0.7\text{ mA}$	4.1	–	–	V
Output Low Voltage	$V_{OL}$	Except XOUT and P3	$V_{DD} = 4.5\text{ V}, I_{OL} = 1.6\text{ mA}$	–	–	0.4	
Output Low Current	$I_{OL3}$	Port P3	$V_{DD} = 4.5\text{ V}, V_{OL} = 1.0\text{ V}$	–	20	–	mA
Supply Current in NORMAL 1, 2 modes	$I_{DD}$		$V_{DD} = 5.5\text{ V}$ $f_c = 8\text{ MHz}$ $f_s = 32.768\text{ kHz}$ $V_{IN} = 5.3\text{ V} / 0.2\text{ V}$	–	8.5	12	mA
Supply Current in IDLE 1, 2 modes				–	3.5	5	mA
Supply Current in NORMAL 1, 2 modes			$V_{DD} = 3.0\text{ V}, V_{IN} = 2.8\text{ V} / 0.2\text{ V}$ $f_c = 4.19\text{ kHz}$ $f_s = 32.768\text{ kHz}$	–	2.5	3.5	mA
Supply Current in IDLE 1, 2 modes				–	1.5	2.0	mA
Supply Current in SLOW mode			$V_{DD} = 3.0\text{ V}$ $f_s = 32.768\text{ kHz}$ $V_{IN} = 2.8\text{ V} / 0.2\text{ V}$	–	30	60	$\mu\text{A}$
Supply Current in SLEEP mode				–	15	30	$\mu\text{A}$
Supply Current in STOP mode			$V_{DD} = 5.5\text{ V}$ $V_{IN} = 5.3\text{ V} / 0.2\text{ V}$	–	0.5	10	$\mu\text{A}$

Note 1: Typical value show those at  $T_{opr} = 25^\circ\text{C}$ .

Note 2: Input Current  $I_{IN1}, I_{IN3}$ ; The current through resistor is not included, when the input resistor (pull-up or pull-down) is contained.

A.C. Characteristics

( $V_{SS} = 0\text{ V}$ ,  $V_{DD} = 4.5\text{ to }6.0\text{ V}$ ,  $T_{opr} = -30\text{ to }70^\circ\text{C}$ )

Parameter	Symbol	Conditions	Min	Typ.	Max	Unit
Machine Cycle Time	$t_{cy}$	In NORMAL1, 2 modes	0.5	-	10	$\mu\text{s}$
		In IDLE1, 2 modes				
		In SLOW mode	117.6	-	133.3	
		In SLEEP mode				
High Level Clock Pulse Width	$t_{WCH}$	For external clock operation (XIN input), $f_c = 8\text{ MHz}$	50	-	-	ns
Low Level Clock Pulse Width	$t_{WCL}$					
High Level Clock Pulse Width	$t_{WSH}$	For external clock operation (XTIN input), $f_s = 32.768\text{ kHz}$	14.7	-	-	$\mu\text{s}$
Low Level Clock Pulse Width	$t_{WSL}$					

Recommended Oscillating Conditions

( $V_{SS} = 0\text{ V}$ ,  $V_{DD} = 4.5\text{ to }6.0\text{ V}$ ,  $T_{opr} = -30\text{ to }70^\circ\text{C}$ )

Parameter	Oscillator	Oscillation Frequency	Recommended Oscillator		Recommended Constant	
					$C_1$	$C_2$
High-frequency Oscillation	Ceramic Resonator	8 MHz	KYOCERA	KBR8.0M	30 pF	30 pF
		4 MHz	KYOCERA	KBR4.0MS		
	Crystal Oscillator	8 MHz	TOYOCOM	210B 8.0000	20 pF	20 pF
		4 MHz	TOYOCOM	204B 4.0000		
Low-frequency Oscillation	Crystal Oscillator	32.768 kHz	NDK	MX-38T	15 pF	15 pF

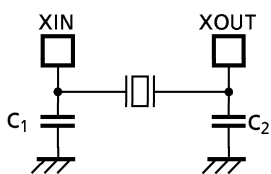

(1) High-frequency Oscillation

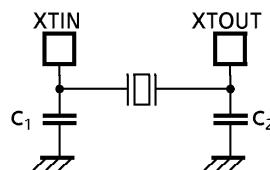

(2) Low-frequency Oscillation

*Note: When used in high electric field such as a picture tube, the package is recommended to be electrically shielded to maintain a regular operation.*

D.C./A.C. Characteristics (PROM mode) ( $V_{SS} = 0\text{ V}$ )

(1) Read Operation ( $T_{opr} = -30\text{ to }70^\circ\text{C}$ )

Parameter	Symbol	Conditions	Min	Typ.	Max	Unit
Input High Voltage	$V_{IH4}$		$V_{CC} \times 0.7$	–	$V_{CC}$	V
Input Low Voltage	$V_{IL4}$		0	–	$V_{CC} \times 0.12$	V
Power Supply Voltage	$V_{CC}$		4.75	5.00	5.25	V
Program Power Supply Voltage	$V_{PP}$		$V_{CC} - 0.6$	$V_{CC}$	$V_{CC} + 0.6$	
Address Access Time	$t_{ACC}$	$V_{CC} = 5.0 \pm 0.25\text{ V}$	–	$1.5\ t_{cyc} + 300$	–	ns

Note:  $t_{cyc} = 500\text{ ns}$  at 8 MHz

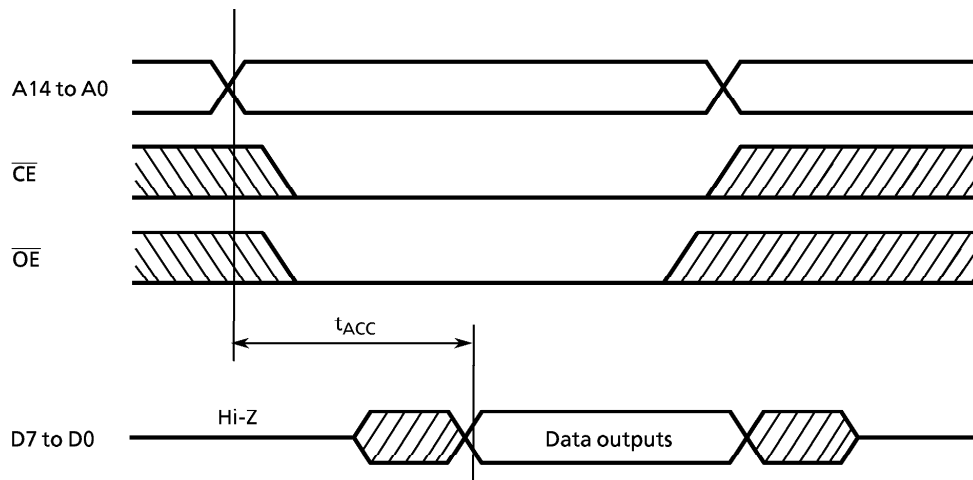

Timing Waveforms of Read Operation



(2) Program Operation (High-Speed Write Mode - I ) ( $T_{opr} = 25 \pm 5^{\circ}\text{C}$ )

Parameter	Symbol	Conditions	Min	Typ.	Max	Unit
Input High Voltage	$V_{IH4}$		$V_{CC} \times 0.7$	-	$V_{CC}$	V
Input Low Voltage	$V_{IL4}$		0	-	$V_{CC} \times 0.12$	V
Power Supply Voltage	$V_{CC}$		5.75	6.0	6.25	V
Program Power Supply Voltage	$V_{PP}$		12.0	12.5	13.0	V
Initial Program Pulse Width	$t_{PW}$	$V_{CC} = 6.0\text{ V} \pm 0.25\text{ V}$ $V_{PP} = 12.5 \pm 0.5\text{ V}$	0.95	1.0	1.05	ms

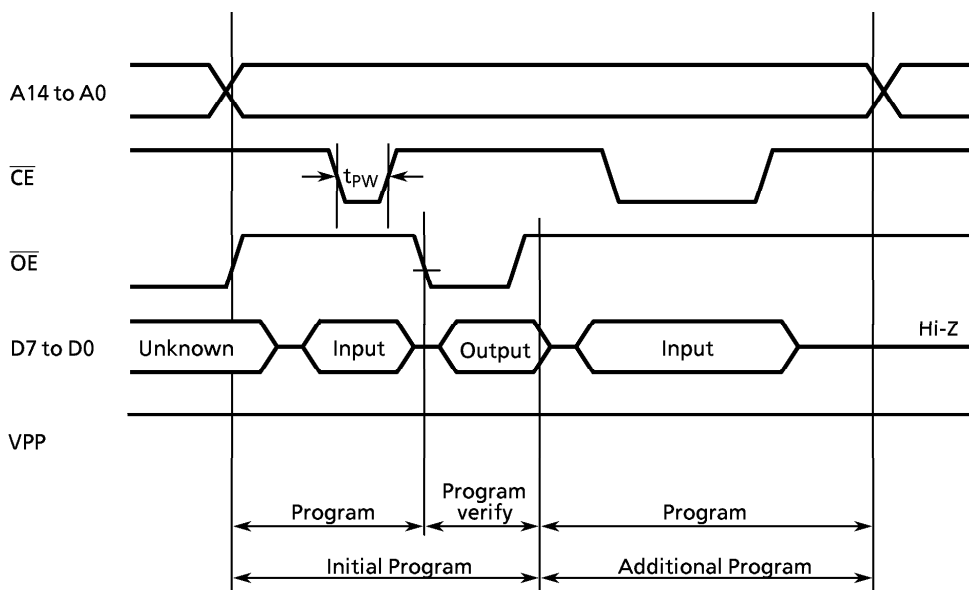

Timing Waveforms of Programming Operation

- Note 1:** When  $V_{CC}$  power supply is turned on or after,  $V_{PP}$  must be increased.  
When  $V_{CC}$  power supply is turned off or before,  $V_{PP}$  must be decreased.
- Note 2:** The device must not be set to the EPROM programmer or picked up from it under applying the program voltage ( $12.5\text{ V} \pm 0.5\text{ V}$ ) to the  $V_{PP}$  pin as the device is damaged.
- Note 3:** Be sure to execute the recommended programming mode with the recommended programming adaptor. If a mode or an adaptor except the above, the misoperation sometimes occurs.

(3) Program Operation (High speed write mode - II) ( $T_{opr} = 25 \pm 5 \text{ }^\circ\text{C}$ )

Parameter	Symbol	Conditions	Min	Typ.	Max	Unit
Input High Voltage	$V_{IH4}$		$V_{CC} \times 0.7$	–	$V_{CC}$	V
Input Low Voltage	$V_{IL4}$		0	–	$V_{CC} \times 0.12$	V
Supply Voltage	$V_{CC}$		6.00	6.25	6.50	V
Program Supply Voltage	$V_{PP}$		12.50	12.75	13.0	V
Initial Program Pulse Width	$t_{PW}$	$V_{CC} = 6.25 \text{ V} \pm 0.25 \text{ V}$ , $V_{PP} = 12.75 \text{ V} \pm 0.25 \text{ V}$	0.095	0.1	0.105	ms

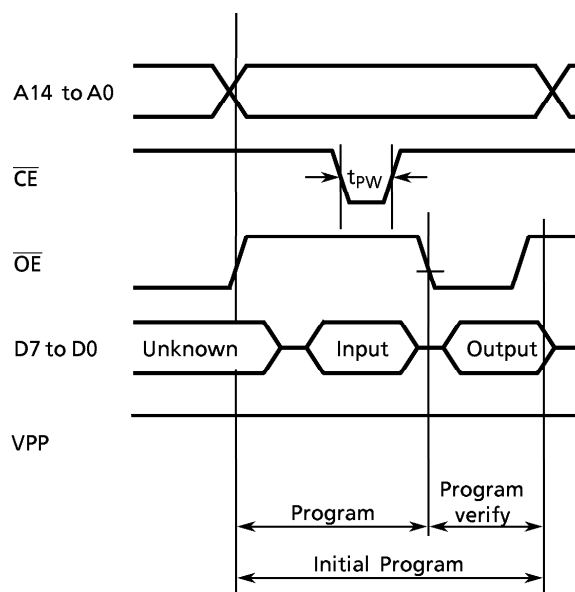

**Note 1:** When  $V_{CC}$  power supply is turned on or after,  $V_{pp}$  must be increased.  
When  $V_{CC}$  power supply is turned off or before,  $V_{pp}$  must be decreased.

**Note 2:** The device must not be set to the EPROM programmer or picked up from it under applying the program voltage ( $12.75 \text{ V} \pm 0.25 \text{ V}$ ) to the  $V_{pp}$  pin as the device is damaged.

**Note 3:** Be sure to execute the recommended programming mode with the recommended programming adaptor. If a mode or an adaptor except the above, the misoperation sometimes occurs.

## Electrical Characteristics

## Absolute Maximum Ratings

 $(V_{SS} = 0\text{ V})$ 

Parameter	Symbol	Conditions	Ratings	Unit
Supply Voltage	$V_{DD}$		- 0.3 to 6.5	V
Program Voltage	$V_{PP}$	TEST / VPP pin	- 0.3 to 13.0	V
Input Voltage	$V_{IN}$		- 0.3 to $V_{DD} + 0.3$	V
Output Voltage	$V_{OUT}$		- 0.3 to $V_{DD} + 0.3$	V
Output Current (Per 1 pin)	$I_{OUT1}$	Ports P0, P1, P2, P4, P5, P6, P7	3.2	mA
	$I_{OUT2}$	Port P3	30	
Output Current (Total)	$\Sigma I_{OUT1}$	Ports P0, P1, P2, P4, P5, P6, P7	120	mA
	$\Sigma I_{OUT2}$	Port P3	120	
Power Dissipation [ $T_{opr} = 70^{\circ}\text{C}$ ]	PD		350	mW
Soldering Temperature (time)	$T_{sld}$		260 (10 s)	$^{\circ}\text{C}$
Storage Temperature	$T_{stg}$		- 55 to 125	$^{\circ}\text{C}$
Operating Temperature	$T_{opr}$		- 30 to 70	$^{\circ}\text{C}$

*Note: The absolute maximum ratings are rated values which must not be exceeded during operation, even for an instant. Any one of the ratings must not be exceeded. If any absolute maximum rating is exceeded, a device may break down or its performance may be degraded, causing it to catch fire or explode resulting in injury to the user. Thus, when designing products which include this device, ensure that no absolute maximum rating value will ever be exceeded.*

## Recommended Operating Conditions

 $(V_{SS} = 0\text{ V}, T_{opr} = -30\text{ to }70^{\circ}\text{C})$ 

Parameter	Symbol	Pins	Conditions	Min	Max	Unit
Supply Voltage	$V_{DD}$		$f_c = 8\text{ MHz}$	NORMAL1, 2 mode	4.5	V
				IDLE1, 2 mode		
			$f_c = 4.2\text{ MHz}$	NORMAL1, 2 mode	1.8	
				IDLE1, 2 mode		
			$f_s = 32.768\text{ kHz}$	SLOW mode		
SLEEP mode						
		STOP mode				
Input High Voltage	$V_{IH1}$	Except Hysteresis inputs	$V_{DD} \geq 4.5\text{ V}$	$V_{DD} \times 0.7$	$V_{DD}$	V
	$V_{IH2}$	Hysteresis inputs		$V_{DD} \times 0.75$		
	$V_{IH3}$			$V_{DD} < 4.5\text{ V}$		
Input Low Voltage	$V_{IL1}$	Except Hysteresis inputs	$V_{DD} \geq 4.5\text{ V}$	0	$V_{DD} \times 0.28$	V
	$V_{IL2}$	Hysteresis inputs		$V_{DD} \times 0.25$		
	$V_{IL3}$			$V_{DD} < 4.5\text{ V}$	$V_{DD} \times 0.10$	
Clock Frequency	$f_c$	XIN, XOUT	$V_{DD} = 4.5\text{ to }5.5\text{ V}$	0.4	8.0	MHz
			$V_{DD} = 1.8\text{ to }4.5\text{ V}$		4.2	
	$f_s$	XTIN, XOUT		30.0	34.0	kHz

*Note: The recommended operating conditions for a device are operating conditions under which it can be guaranteed that the device will operate as specified. If the device is used under operating conditions other than the recommended operating conditions (supply voltage, operating temperature range, specified AC/DC values etc.), malfunction may occur. Thus, when designing products which include this device, ensure that the recommended operating conditions for the device are always adhered to.*

D.C. Characteristics

(V<sub>SS</sub> = 0 V, T<sub>opr</sub> = - 30 to 70°C)

Parameter	Symbol	Pins	Conditions	Min	Typ.	Max	Unit
Hysteresis Voltage	V <sub>HS</sub>	Hysteresis inputs	V <sub>DD</sub> = 5.0 V	-	0.9	-	V
Input Current	I <sub>IN1</sub>	TEST	V <sub>DD</sub> = 5.5 V V <sub>IN</sub> = 5.5 V / 0 V	-	-	± 2	μA
	I <sub>IN2</sub>	Open drain ports and tri-state ports					
	I <sub>IN3</sub>	RESET, STOP					
Input Low Current	I <sub>IL</sub>	Push-pull ports	V <sub>DD</sub> = 5.5 V, V <sub>IN</sub> = 0.4 V	-	-	- 2	mA
Input Resistance	R <sub>IN1</sub>	Port P7 with pull-up	V <sub>DD</sub> = 5.0 V	30	70	150	kΩ
	R <sub>IN2</sub>	RESET	V <sub>DD</sub> = 5.0 V	100	220	450	
Output Leakage Current	I <sub>LO1</sub>	Open drain ports	V <sub>DD</sub> = 5.5 V, V <sub>OUT</sub> = 5.5 V	-	-	2	μA
	I <sub>LO2</sub>	Tri-state ports	V <sub>DD</sub> = 5.5 V, V <sub>OUT</sub> = 5.5 V / 0 V	-	-	± 2	
Output High Voltage	V <sub>OH1</sub>	Push-pull ports	V <sub>DD</sub> = 4.5 V, I <sub>OH</sub> = - 200 μA	2.4	-	-	V
	V <sub>OH2</sub>	Tri-state ports	V <sub>DD</sub> = 4.5 V, I <sub>OH</sub> = - 0.7 mA	4.1	-	-	
	V <sub>OH3</sub>	Push-pull ports	V <sub>DD</sub> = 1.8 V, I <sub>OH</sub> = - 5 μA	1.6	-	-	
Output Low Voltage	V <sub>OH4</sub>	Tri-state ports	V <sub>DD</sub> = 1.8 V, I <sub>OH</sub> = - 10 μA	1.6	-	-	
	V <sub>OL1</sub>	Except XOUT and port P3	V <sub>DD</sub> = 4.5 V, I <sub>OL</sub> = 1.6 mA	-	-	0.4	
	V <sub>OL2</sub>	Except XOUT	V <sub>DD</sub> = 1.8 V, I <sub>OL</sub> = 20 μA	-	-	0.2	
Output Low Current	I <sub>OL3</sub>	Port P3	V <sub>DD</sub> = 4.5 V, V <sub>OL</sub> = 1.0 V	-	20	-	mA
Supply Current in NORMAL 1, 2 mode	I <sub>DD</sub>		V <sub>DD</sub> = 5.5 V f <sub>c</sub> = 8 MHz f <sub>s</sub> = 32.768 kHz V <sub>IN</sub> = 5.3 V / 0.2 V	-	7.0	10	
Supply Current in IDLE 1, 2 mode				-	3.5	5	
Supply Current in NORMAL 1, 2 mode			V <sub>DD</sub> = 3.0 V f <sub>c</sub> = 4.19 MHz f <sub>s</sub> = 32.768 kHz V <sub>IN</sub> = 2.8 V / 0.2 V	-	2.5	3.5	
Supply Current in IDLE 1, 2 mode				-	1.5	2.0	
Supply Current in NORMAL 1, 2 mode			V <sub>DD</sub> = 1.8 V f <sub>c</sub> = 4.19 MHz f <sub>s</sub> = 32.768 kHz V <sub>IN</sub> = 1.7 V / 0.1 V	-	1.0	2.0	
Supply Current in IDLE 1, 2 mode				-	0.5	1.0	
Supply Current in SLOW mode			V <sub>DD</sub> = 3.0 V f <sub>s</sub> = 32.768 kHz V <sub>IN</sub> = 2.8 V / 0.2 V	-	30	60	
Supply Current in SLEEP mode				-	15	30	
Supply Current in SLOW mode				V <sub>DD</sub> = 1.8 V f <sub>s</sub> = 32.768 kHz V <sub>IN</sub> = 1.7 V / 0.1 V	-	15	
Supply Current in SLEEP mode					-	10	20
Supply Current in STOP mode	V <sub>DD</sub> = 5.5 V V <sub>IN</sub> = 5.3 V / 0.2 V	-	0.5	10			

Note 1: Typical values show those at T<sub>opr</sub> = 25°C, V<sub>DD</sub> = 3V.

Note 2: Input Current ; The current through pull-up or pull-down resistor is not included.

**A.C. Characteristics**

(V<sub>SS</sub> = 0 V, V<sub>DD</sub> = 4.5 to 5.5 V, T<sub>opr</sub> = - 30 to 70°C)

Parameter	Symbol	Conditions	Min	Typ.	Max	Unit
Machine Cycle Time	t <sub>cy</sub>	In NORMAL 1, 2 mode	0.5	-	10	μs
		In IDLE 1, 2 mode				
		In SLOW mode	117.6	-	133.3	
		In SLEEP mode				
High Level Clock Pulse Width	t <sub>WCH</sub>	For external clock operation (XIN input) , fc = 8.4 MHz	50	-	-	ns
Low Level Clock Pulse Width	t <sub>WCL</sub>					
High Level Clock Pulse Width	t <sub>WSH</sub>	For external clock operation (XTIN input), fs = 32.768 kHz	14.7	-	-	μs
Low Level Clock Pulse Width	t <sub>WSL</sub>					

(V<sub>SS</sub> = 0 V, V<sub>DD</sub> = 1.8 to 4.5 V, T<sub>opr</sub> = - 30 to 70°C)

Parameter	Symbol	Conditions	Min	Typ.	Max	Unit
Machine Cycle Time	t <sub>cy</sub>	In NORMAL 1, 2 mode	0.95	-	10	μs
		In IDLE 1, 2 mode				
		In SLOW mode	117.6	-	133.3	
		In SLEEP mode				
High Level Clock Pulse Width	t <sub>WCH</sub>	For external clock operation (XIN input) , fc = 4.2 MHz	110	-	-	ns
Low Level Clock Pulse Width	t <sub>WCL</sub>					
High Level Clock Pulse Width	t <sub>WSH</sub>	For external clock operation (XTIN input), fs = 32.768 kHz	14.7	-	-	μs
Low Level Clock Pulse Width	t <sub>WSL</sub>					

**Recommended Oscillating Conditions**

(V<sub>SS</sub> = 0 V, T<sub>opr</sub> = - 30 to 70°C)

Parameter	Oscillator	Oscillation Frequency	Recommended Oscillator		Recommended Constant	
					C <sub>1</sub>	C <sub>2</sub>
High-frequency	Ceramic Resonator	4.19 MHz (V <sub>DD</sub> = 1.8 to 5.5 V)	MURATA	CSA4.19MG	30 pF	30 pF
			MURATA	CST4.19MGW	-	-
		8 MHz (V <sub>DD</sub> = 4.5 to 5.5 V)	MURATA	CSA8.00MTZ	15 pF	15 pF
			MURATA	CST8.00MTW	-	-
	Crystal Oscillator	8 MHz (V <sub>DD</sub> = 4.5 to 5.5 V)	NDK	AT-51	16 pF	16 pF
Low-frequency	Crystal Oscillator	32.768 kHz (V <sub>DD</sub> = 1.8 to 5.5 V)	NDK	MX-38T	12 pF	12 pF

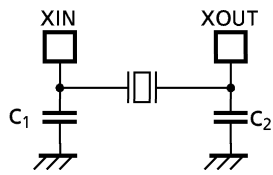

(1) High-frequency Oscillation

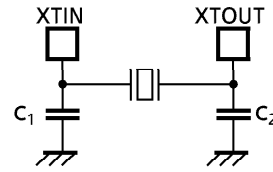

(2) Low-frequency Oscillation

*Note: When used in high electric field such as a picture tube, the package is Recommended to be electrically shielded to maintain a regular operation.*

**D.C./A.C. Characteristics (PROM mode)** ( $V_{SS} = 0\text{ V}$ )

(1) Read Operation ( $T_{opr} = -30\text{ to }70\text{ }^{\circ}\text{C}$ )

Parameter	Symbol	Conditions	Min	Typ.	Max	Unit
Input High Voltage	$V_{IH4}$		$V_{CC} \times 0.7$	–	$V_{CC}$	V
Input Low Voltage	$V_{IL4}$		0	–	$V_{CC} \times 0.12$	V
Power Supply Voltage	$V_{CC}$		4.75	5.00	5.25	V
Program Power Supply Voltage	$V_{PP}$		$V_{CC} - 0.6$	$V_{CC}$	$V_{CC} + 0.6$	
Address Access Time	$t_{ACC}$	$V_{CC} = 5.0 \pm 0.25\text{ V}$	–	$1.5\ t_{cyc} + 300$	–	ns

Note:  $t_{cyc} = 500\text{ ns at }8\text{ MHz}$

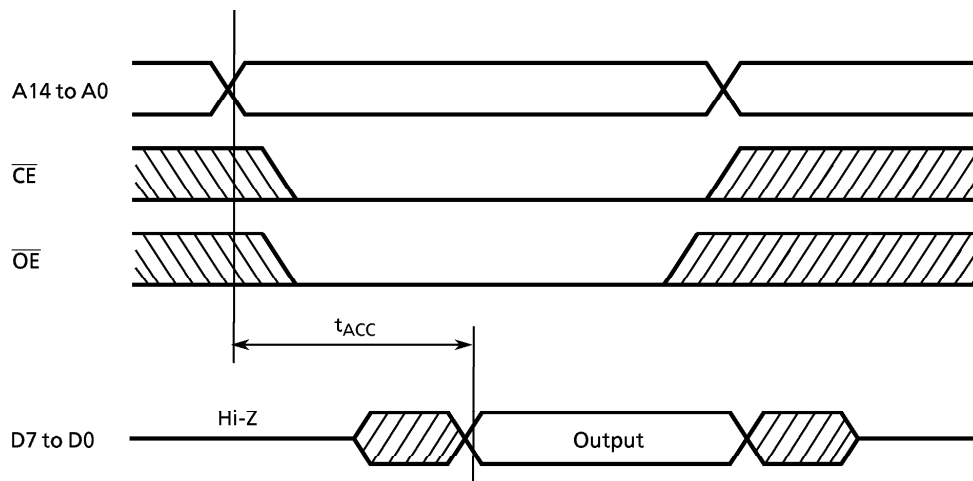

Timing Waveforms of Read Operation

(2) Program Operation (High-Speed Write Mode - I ) ( $T_{opr} = 25 \pm 5^{\circ}\text{C}$ )

Parameter	Symbol	Conditions	Min	Typ.	Max	Unit
Input High Voltage	$V_{IH4}$		$V_{CC} \times 0.7$	-	$V_{CC}$	V
Input Low Voltage	$V_{IL4}$		0	-	$V_{CC} \times 0.12$	V
Power Supply Voltage	$V_{CC}$		5.75	6.0	6.25	V
Program Power Supply Voltage	$V_{PP}$		12.0	12.5	13.0	V
Initial Program Pulse Width	$t_{PW}$	$V_{CC} = 6.0\text{ V} \pm 0.25\text{ V}$ $V_{PP} = 12.5\text{ V} \pm 0.5\text{ V}$	0.95	1.0	1.05	ms

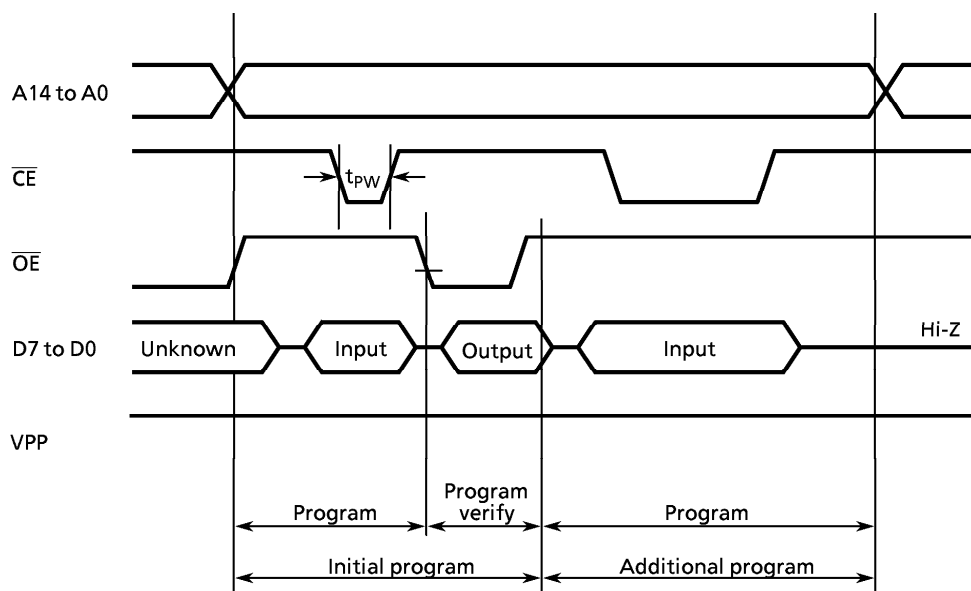

Timing Waveforms of Programming Operation

**Note1:** When  $V_{CC}$  power supply is turned on or after,  $V_{pp}$  must be increased.  
 When  $V_{CC}$  power supply is turned off or before,  $V_{pp}$  must be decreased.

**Note2:** The device must not be set to the EPROM programmer or picked up from it under applying the program voltage ( $12.5\text{ V} \pm 0.5\text{ V}$ ) to the  $V_{pp}$  pin as the device is damaged.

**Note3:** Be sure to execute the Recommended programing mode with the Recommended programing adaptor. If a mode or an adaptor except the above, the misoperation sometimes occurs.



(3) Program Operation (High speed write mode - II) ( $T_{opr} = 25 \pm 5^{\circ}\text{C}$ )

Parameter	Symbol	Conditions	Min	Typ.	Max	Unit
Input High Voltage	$V_{IH4}$		$V_{CC} \times 0.7$	-	$V_{CC}$	V
Input Low Voltage	$V_{IL4}$		0	-	$V_{CC} \times 0.12$	V
Supply Voltage	$V_{CC}$		6.00	6.25	6.50	V
Program Supply Voltage	$V_{PP}$		12.50	12.75	13.0	V
Initial Program Pulse Width	$t_{PW}$	$V_{CC} = 6.25 \text{ V} \pm 0.25 \text{ V}$ , $V_{PP} = 12.75 \text{ V} \pm 0.25 \text{ V}$	0.095	0.1	0.105	ms

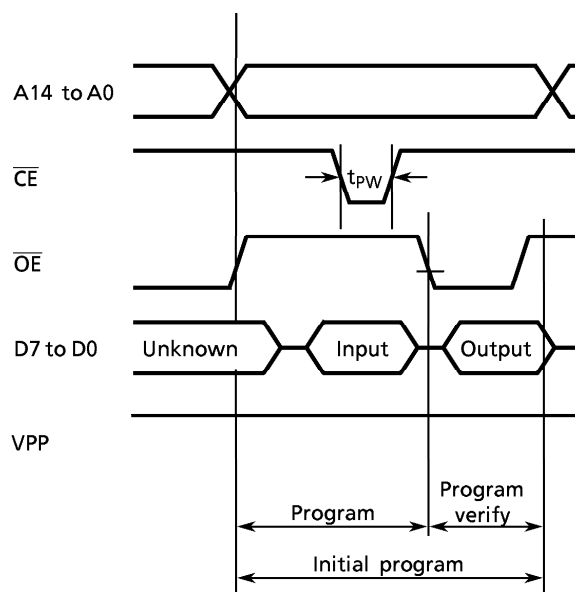

**Note1:** When  $V_{CC}$  power supply is turned on or after,  $V_{pp}$  must be increased.

When  $V_{CC}$  power supply is turned off or before,  $V_{pp}$  must be decreased.

**Note2:** The device must not be set to the EPROM programmer or picked up from it under applying the program voltage ( $12.75 \text{ V} \pm 0.25 \text{ V}$ ) to the  $V_{pp}$  pin as the device is damaged.

**Note3:** Be sure to execute the Recommended programming mode with the Recommended programming adaptor. If a mode or an adaptor except the above, the misoperation sometimes occurs.