

BIT MAP LCD DRIVER

■ GENERAL DESCRIPTION

The NJU6572 is a bit map LCD driver to display graphics or characters.

It contains 2,560 bit display data RAM, microprocessor interface circuits, instruction decoder, and 16-common and 61-segment drivers.

The bit image display data sent from 8- or 16-bit MPU are stored in the display data RAM and drives Dot Matrix LCD Panel by the common and segment drivers.

The 16-common and 61-segment drivers can drive graphics or 12-character 2-line with icon data.

The NJU6572 can combine with the NJU6572 or 6453A to expand the display capacity to 32 x 122 dots or 16 x 141 dots of graphics or character display by using the extension function of NJU6572.

Furthermore, low current consumption due to the external clock input and wide operating voltage are useful apply to the small sized battery operated items.

■ PACKAGE OUTLINE

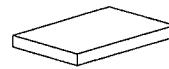

NJU6572C

■ FEATURES

- Direct Correspondence between Display Data RAM and LCD Pixel
- Display Data RAM - 2,560 bits 80 x 8 x 4
- Direct Interface with 8- or 16-bit MPU
(Both of 68 and 80 type MPU can connect directly)
- Extension Function (can combine with NJU6572 or 6453A)
- Read Out From the Display Data RAM
- 16-common and 61-segment Drivers
- Programmable Duty Ratio ; 1/16 or 1/32 Duty
- Useful Instruction Set
Display Data Read/Write, Display ON/OFF Cont, Display Data RAM Address Set, Status Read,
Display Starting Line Set, Static Drive ON/OFF, Duty Ratio Setting, and Read Modify Write,
- Low Power Consumption
- External Clock Input (2kHz)
- Operating Voltage --- 2.4V - 5.5V
- LCD Driving Voltage --- 10.0V
- Package Outline --- Chip
- C-MOS Technology

■ BLOCK DIAGRAM

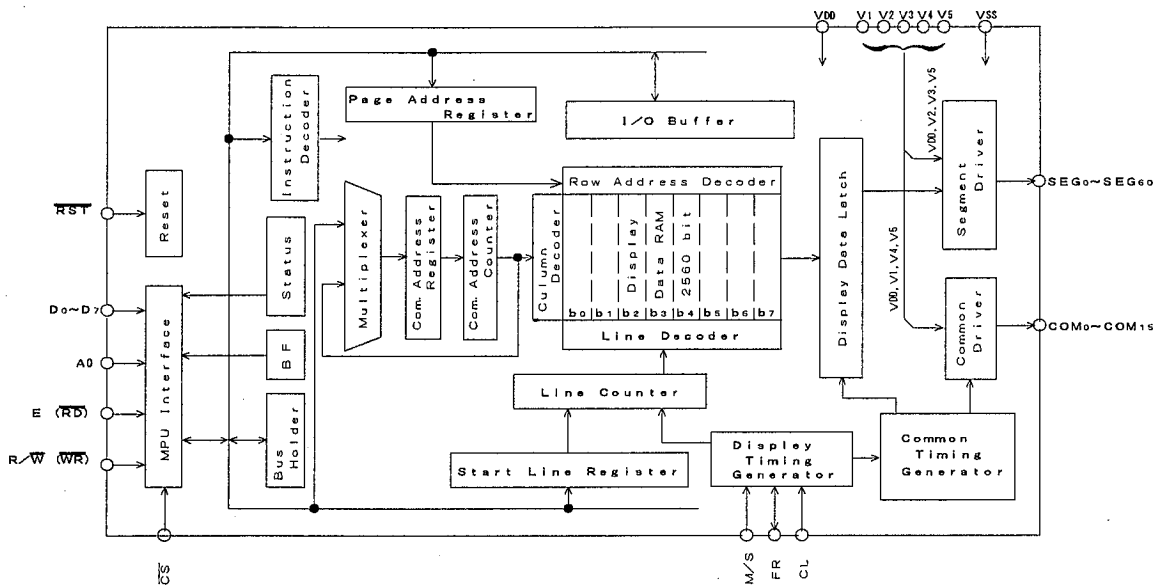

■ PAD LOCATION

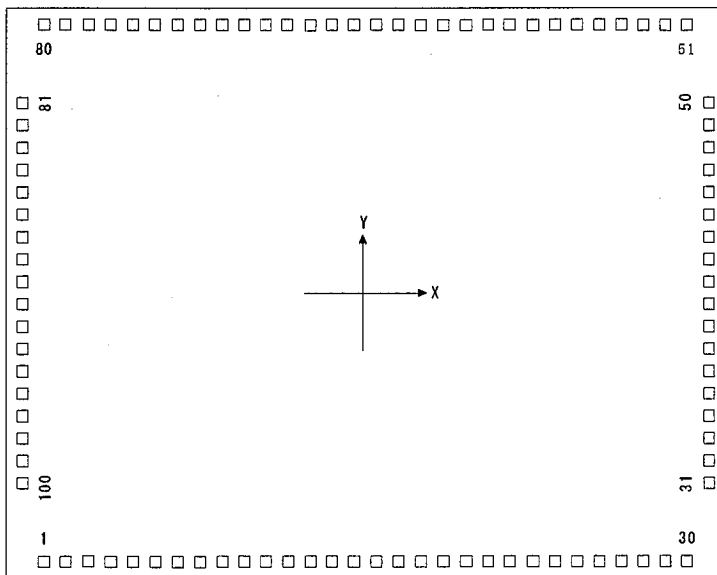

Chip Cente : X=0um, Y=0um
 Chip Size : X=4.37mm, Y=3.25mm
 Chip Thickness : 400um ± 30um
 Pad Size : 100.8um × 100.8um
 Pad Pitch : 140um



NJU6572

■ PAD COORDIATES

Chip Size 4.37mm x 3.25mm(Chip Center X=0um, Y=0um)

PAD No.	Terminal	X=(um)	Y=(um)
1	COM5	-2031	-1471
2	COM6	-1891	-1471
3	COM7	-1751	-1471
4	COM8	-1611	-1471
5	COM9	-1471	-1471
6	COM10	-1331	-1471
7	COM11	-1191	-1471
8	COM12	-1051	-1471
9	COM13	-911	-1471
10	COM14	-771	-1471
11	COM15	-631	-1471
12	SEG60	-491	-1471
13	SEG59	-351	-1471
14	SEG58	-211	-1471
15	SEG57	-71	-1471
16	SEG56	70	-1471
17	SEG55	210	-1471
18	SEG54	350	-1471
19	SEG53	490	-1471
20	SEG52	630	-1471
21	SEG51	770	-1471
22	SEG50	910	-1471
23	SEG49	1050	-1471
24	SEG48	1190	-1471
25	SEG47	1330	-1471
26	SEG46	1470	-1471
27	SEG45	1610	-1471
28	SEG44	1750	-1471
29	SEG43	1890	-1471
30	SEG42	2030	-1471
31	SEG41	2030	-1331
32	SEG40	2030	-1191
33	SEG39	2030	-1051
34	SEG38	2030	-911
35	SEG37	2030	-771
36	SEG36	2030	-631
37	SEG35	2030	-491
38	SEG34	2030	-351
39	SEG33	2030	-211
40	SEG32	2030	-71
41	SEG31	2030	70
42	SEG30	2030	210
43	SEG29	2030	350
44	SEG28	2030	490
45	SEG27	2030	630
46	SEG26	2030	770
47	SEG25	2030	910
48	SEG24	2030	1050
49	SEG23	2030	1190
50	SEG22	2030	1330

PAD No.	Terminal	X=(um)	Y=(um)
51	SEG21	2030	1470
52	SEG20	1890	1470
53	SEG19	1750	1470
54	SEG18	1610	1470
55	SEG17	1470	1470
56	SEG16	1330	1470
57	SEG15	1190	1470
58	SEG14	1050	1470
59	SEG13	910	1470
60	SEG12	770	1470
61	SEG11	630	1470
62	SEG10	490	1470
63	SEG9	350	1470
64	SEG8	210	1470
65	SEG7	70	1470
66	SEG6	-71	1470
67	SEG5	-211	1470
68	SEG4	-351	1470
69	SEG3	-491	1470
70	SEG2	-631	1470
71	SEG1	-771	1470
72	SEG0	-911	1470
73	A0	-1051	1470
74	CS	-1191	1470
75	CL	-1331	1470
76	E(RD)	-1471	1470
77	R/W(WR)	-1611	1470
78	VSS	-1751	1470
79	DB0	-1891	1470
80	DB1	-2031	1470
81	DB2	-2031	1330
82	DB3	-2031	1190
83	DB4	-2031	1050
84	DB5	-2031	910
85	DB6	-2031	770
86	DB7	-2031	630
87	VDD	-2031	490
88	RST	-2031	350
89	FR	-2031	210
90	V5	-2031	70
91	V3	-2031	-71
92	V2	-2031	-211
93	M/S	-2031	-351
94	V4	-2031	-491
95	V1	-2031	-631
96	COM0	-2031	-771
97	COM1	-2031	-911
98	COM2	-2031	-1051
99	COM3	-2031	-1191
100	COM4	-2031	-1331

New Japan Radio Co., Ltd.

Terminal Description

No.	Symbol	F u n c t i o n															
87	V _{DD}	Power Supply : V _{DD} =+5V															
78	V _{SS}	GND : V _{SS} = 0V															
95, 92 91, 94, 90	V ₁ , V ₂ V ₃ , V ₄ , V ₅	LCD Driving Voltage Supplying Terminal. Following relation must be maintained. V _{DD} ≥ V ₁ ≥ V ₂ ≥ V ₃ ≥ V ₄ ≥ V ₅															
74	CS	Chip Select Signal Input Terminal. Normally input the decoded signal of Address Bus Signal. Active "L".															
75	CL	Display Data Latch Signal Input Terminal. The Line Counter also count up by this signal rising timing. The synchronized signal of the NJU6470 is required.															
76	E (\overline{RD})	<When connect to the 68 type MPU> Connect to Enable Clock Input Terminal of 68 type MPU. Active "H". <When connect to the 80 type MPU> Connect to \overline{RD} Signal Input Terminal of 80 type MPU. Active "L" During this terminal is "L", the Data Bus is output state.															
77	R/W (\overline{WR})	<When connect to the 68 type MPU> Connect to READ/WRITE Control Signal Input Terminal of 68 type MPU. <table border="1" style="margin-left: auto; margin-right: auto;"> <tr> <td>R/W</td> <td>H</td> <td>L</td> </tr> <tr> <td>Status</td> <td>Read</td> <td>Write</td> </tr> </table> <When connect to the 80 type MPU> Connect to \overline{WR} Signal connecting terminal of 80 type MPU. Active "L". The data on the Data Bus is fetch at the rising edge of this signal.	R/W	H	L	Status	Read	Write									
R/W	H	L															
Status	Read	Write															
73	A0	Connect to the Address Bus of MPU. The data on the D ₀ ~D ₇ is distinguished between Display Data and Instruction. <table border="1" style="margin-left: auto; margin-right: auto;"> <tr> <td>A0</td> <td>H</td> <td>L</td> </tr> <tr> <td>Data</td> <td>Display Data</td> <td>Instruction</td> </tr> </table>	A0	H	L	Data	Display Data	Instruction									
A0	H	L															
Data	Display Data	Instruction															
79~86	D ₀ ~D ₇	Tri-state bilateral Data Bus. The data transmission between 8- or 16-bit MPU and NJU6572 is executed by this Bus.															
89	FR	Alternating signal for LCD Driving output or input terminal. Output or input is determined by master or slave mode which selected by M/S terminal. <table border="1" style="margin-left: auto; margin-right: auto;"> <tr> <td>M/S</td> <td>Master</td> <td>Slave</td> </tr> <tr> <td>FR</td> <td>Output</td> <td>Input</td> </tr> </table>	M/S	Master	Slave	FR	Output	Input									
M/S	Master	Slave															
FR	Output	Input															
96~100 1~11	COM ₀ ~ COM ₄ (COM ₃₁ ~ COM ₂₇) COM ₅ ~ COM ₁₅ (COM ₂₆ ~ COM ₁₆) (Note)	Common output terminal. One output level out of V _{DD} , V ₁ , V ₄ , V ₅ is Selected by combination of FR and data of common counter. <table border="1" style="margin-left: auto; margin-right: auto;"> <tr> <td>FR</td> <td colspan="2">H</td> <td colspan="2">L</td> </tr> <tr> <td>Data</td> <td>H</td> <td>L</td> <td>H</td> <td>L</td> </tr> <tr> <td>Output</td> <td>V₅</td> <td>V₁</td> <td>V_{DD}</td> <td>V₄</td> </tr> </table>	FR	H		L		Data	H	L	H	L	Output	V ₅	V ₁	V _{DD}	V ₄
FR	H		L														
Data	H	L	H	L													
Output	V ₅	V ₁	V _{DD}	V ₄													
72~12	SEG ₀ ~ SEG ₆₀	Segment output terminal. One output level out of V _{DD} , V ₂ , V ₃ , V ₅ is Selected by combination of FR and data of Display RAM. <table border="1" style="margin-left: auto; margin-right: auto;"> <tr> <td>FR</td> <td colspan="2">H</td> <td colspan="2">L</td> </tr> <tr> <td>Data</td> <td>H</td> <td>L</td> <td>H</td> <td>L</td> </tr> <tr> <td>Output</td> <td>V_{DD}</td> <td>V₂</td> <td>V₅</td> <td>V₃</td> </tr> </table>	FR	H		L		Data	H	L	H	L	Output	V _{DD}	V ₂	V ₅	V ₃
FR	H		L														
Data	H	L	H	L													
Output	V _{DD}	V ₂	V ₅	V ₃													
88	RST	Reset and interface type select terminal. The reset operation is performed by rise or fall edge of this signal. The input level after initialization selects the interface type of 68 Or 80 type of MPU. <table border="1" style="margin-left: auto; margin-right: auto;"> <tr> <td>MPU</td> <td>Edge</td> <td>Input Level after Initialization</td> </tr> <tr> <td>68 Type</td> <td>Rise</td> <td>H</td> </tr> <tr> <td>80 Type</td> <td>Fall</td> <td>L</td> </tr> </table>	MPU	Edge	Input Level after Initialization	68 Type	Rise	H	80 Type	Fall	L						
MPU	Edge	Input Level after Initialization															
68 Type	Rise	H															
80 Type	Fall	L															
93	M/S (Note)	Master or Slave operation selecting terminal. Connect to V _{DD} or V _{SS} . M/S=V _{DD} : Master, M/S=V _{SS} : Slave The function of FR, COM ₀ ~COM ₁₅ , OSC ₁ , and OSC ₂ is changed by M/S. <table border="1" style="margin-left: auto; margin-right: auto;"> <tr> <td>M/S</td> <td>FR</td> <td>Common Output</td> <td>OSC₁</td> <td>OSC₂</td> </tr> <tr> <td>Master</td> <td>Out</td> <td>COM₀ ~ COM₁₅</td> <td>In</td> <td>Out</td> </tr> <tr> <td>Slave</td> <td>In</td> <td>COM₃₁ ~ COM₁₆</td> <td>NC</td> <td>In</td> </tr> </table>	M/S	FR	Common Output	OSC ₁	OSC ₂	Master	Out	COM ₀ ~ COM ₁₅	In	Out	Slave	In	COM ₃₁ ~ COM ₁₆	NC	In
M/S	FR	Common Output	OSC ₁	OSC ₂													
Master	Out	COM ₀ ~ COM ₁₅	In	Out													
Slave	In	COM ₃₁ ~ COM ₁₆	NC	In													

(Note) The common scanning order of slave LSI is inverted against the master LSI.

■ Functional Discription

(1) Description for each blocks

(1-1) Busy Flag (BF)

When the internal circuits are in the operation mode, the busy flag(BF) is "1", and any instruction except the status read are inhibited.

The busy flag is output at D₇ terminal when status read instruction is executed.

If enough cycle time over than t_{cyc} is kept, no need to check the busy flag.

(1-2) Display Start Line Register

The Display Start Line Register is a pointer register which indicate the address in the Display Data RAM corresponded with COM₀ (normally it display the top line in the LCD Panel).

This register can use for scroll the screen, change the display page and so on.

The Display Start Line instruction set the display start address of the Display Data RAM represented in 5-bit to this register.

(1-3) Line Counter

The Display Start Address stored in the Display Start Line Register is set to the Line Counter when the FR signal out from the NJU6572 is changing.

The Line Counter count up by synchronizing common signal out from NJU6572 and generate the line address which addressing the read out line of Display Data RAM.

(1-4) Column Address Counter

The column address counter is 7-bit presettable counter which addressing the column address as shown as Fig. 1.

This counter increments "1" up to 50H when the Display Data Read/Write instruction is executed. The count up is stop at 50H (over 50H is non existing address) automatically by the count lock function.

Furthermore, this counter is independent with the Page Register.

(1-5) Page Register

This register gives page address of Display Data RAM as shown Fig. 1.

When the MPU access the data by changing the page, the page address set instruction is required.

(1-6) Display Data RAM

Display Data Ram consist of 2,560 bits stores the bit image display data (each bit correspond to the each pixel so called bit map method). This RAM and MPU are operating independently, therefore, there is no influence by the unsynchronize rewriting.

The each bit in the Display Data RAM correspond to the each dot of the LCD panel.

On = "1"

Off = "0"

The relation between column address and segment output can inverse by the Address Inverse Instruction ADC as shown Fig. 1.

(1-7) Timing Generator

This Generator generates the common timing and frame signal for 1/16 and 1/32 duty selecting by Duty Select Instruction from the master clock.

In the case of the 1/32 duty, 2 chip of master and slave chip should be combined, and both of common are synchronized by the common multi-chip method. (Refer the figure shown below)

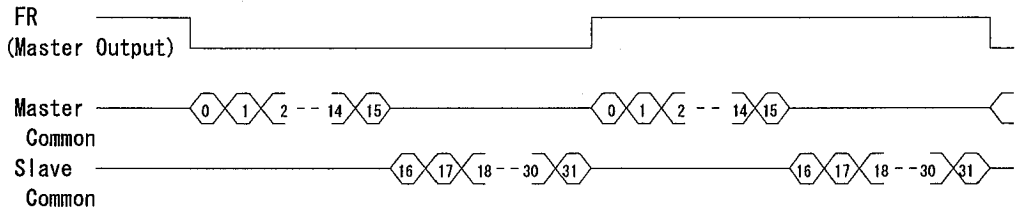

(1-8) Display Data Latch

Display Data Latch stores 80-bit of one line display data for each common cycle which read out from the Display Data RAM temporary and transfer this data to the LCD Driver.

The Display On/Off and Static Drive On/Off controls the latched data only, therefore, the data in the Display Data RAM is no change and keep on remaining.

(1-9) LCD Driving Circuits

This Driver is consists of 80-multiplexer which output the 4-level of LCD driving voltage.

The output waveform is determined by the combination of the data in the Display Data Latch, Common Timing Generator and FR signal.

(1-10) Display Timing Generator

This Generator generates the timing signal for the display system by combination of the master clock and Frame Driving Signal FR. The Frame Driving Signal FR has a function to generate the 2 frame alternative driving method waveform for the LCD panel, and synchronizing the line counter and common timing generator to the master LSI. Therefore, the FR signal must be 50% duty ratio clock signal which synchronized with the frame signal.

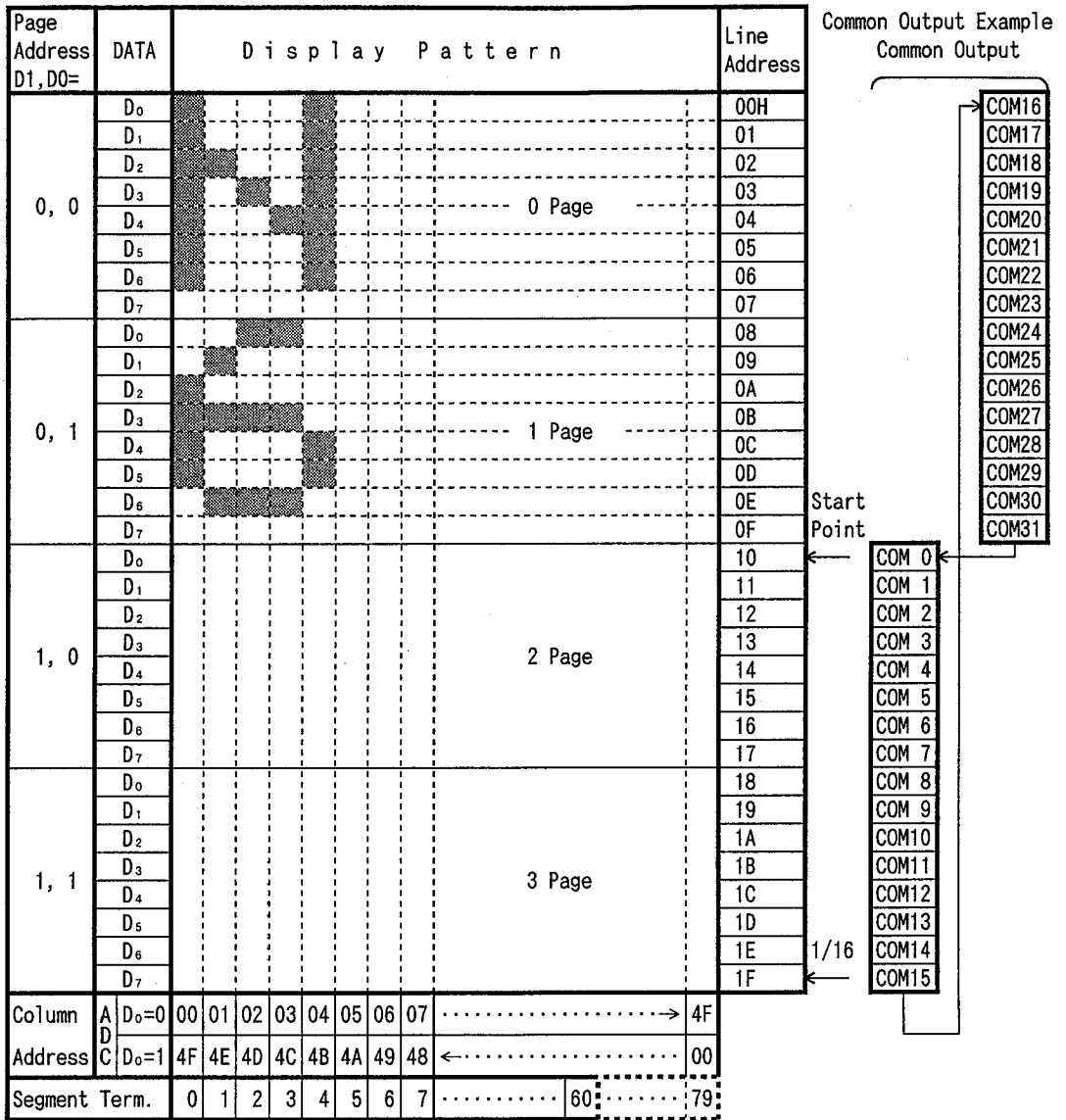

Fig. 1. Correspondence with Display Data RAM and address (For example the display start line is 10th and 1/32 duty)

(1-11) Reset Circuits

The NJU6572 performs following initialization by detecting the rising or falling edge of the \overline{RST} input after the power turns on.

Initialization

- 1, Display Off
- 2, Set the 1st line to the Display Start Register
- 3, Static Drive Off
- 4, Set the address "0" to the Column Address Counter
- 5, Set the page "3" to the Page Address Register
- 6, Select the 1/32 duty
- 7, Select the ADC : Counterclockwise output
(ADC instruction D0 = "0", ADC status flag "1")
- 8, Read Modify Write Mode Off

The \overline{RST} terminal input level is used to select the interface of 80 or 68 type MPU as shown in Table. 2. Therefore, the "H" level input through the inverter is required when connecting the 80 type MPU, and "L" level input is required when connecting the 68 type MPU as shown in application circuits 1.

The \overline{RST} terminal must be connect to the Reset Terminal of MPU and reset at same time with it.

The dead-lock may occur if the no initialization by the \overline{RST} terminal when the power turns on.

By the RESET instruction, the initialization of 2 and 5 mentioned above are executed.

(2) Instruction

The NJU6570 distinguish the signal on the data bus by combination of A0 and R/W(\overline{RD} , \overline{WR}).

Normally, the busy check is not required as the NJU6570 is operating so first because of the decode of the instruction and execution are performs only depend on the internal timing which not depend on the external clock. The Table. 1 shows the instruction codes of the NJU6570.

Table 1. Instruction Code

Instruction	C o d e											Description	
	A0	RD	WR	D ₇	D ₆	D ₅	D ₄	D ₃	D ₂	D ₁	D ₀		
Display On / Off	0	1	0	1	0	1	0	1	1	1	0/1	Whole Display On/Off. 1:On, 0:Off (Power Save mode if the static Drive On)	
Display Start Line	0	1	0	1	1	1	Display Start Address (1~31)				0	Determine the Display Line correspond to the COM.	
Page Address Set	0	1	0	1	0	1	1	1	0	Page (0~3)		Set the Page of Disp. Data RAM to the Page Register.	
Column Address Set	0	1	0	0	Column Address (0~79)						0	Set the Column Address of Display Data RAM to the Column Register.	
Status Read	0	0	1	B U S Y	A D C	O N / O F F	R E S E T	0	0	0	0	Read the status. BUSY 1:Working 0:Ready ADC 1:Clockwise Output 0:Counterclockwise ON/OFF1:Disp Off 0:Disp On RESET 1:Reset 0:Normal	
Write Display Data	1	1	0	Write Data							0	Write the data to the Display Data RAM.	Access the predetermined address of the Display Data RAM. The Column address increment "1" after read or write.
Read Display Data	1	0	1	Read Data							0	Read the data from the Display Data RAM.	
ADC Select	0	1	0	1	0	1	0	0	0	0	0/1	Determine the clockwise or counterclockwise reading of the Display Data RAM. 0:Clockwise Output 1:Counterclockwise Output	
Static Drive On / Off	0	1	0	1	0	1	0	0	1	0	0/1	Select the Dynamic or Static Driving. 1:Static Driving (Power Saving) 0:Dynamic Driving	
Duty Ratio Select	0	1	0	1	0	1	0	1	0	0	0/1	Select the duty ratio. 1:1/32 Duty 0:1/16 Duty	
Read Modify Write	0	1	0	1	1	1	0	0	0	0	0	Increment the Column Address register when writing but no-change when reading.	
End	0	1	0	1	1	1	0	1	1	1	0	Release from the Read Modify Write Mode.	
Reset	0	1	0	1	1	1	0	0	0	1	0	Set the Display Start Line Register to 1st line, Page Add. Register to "0".	
Power Save (Dual Command)	0	1	0	1	0	1	0	1	1	1	0	Set the power save mode by selecting Display Off and Static Driving On. (The order is possible even if it is opposite.)	
	0	1	0	1	0	1	0	0	1	0	1		

(3) Explanation of Instruction Code.

(a) Display On/Off

This instruction executes whole display On/Off no relation with the data in the Display Data RAM and internal conditions.

	A0	\overline{RD}	R/W WR	D ₇	D ₆	D ₅	D ₄	D ₃	D ₂	D ₁	D ₀
Code	0	1	0	1	0	1	0	1	1	1	D

D 0 : Display Off
1 : Display On

When the static driving mode is selected (static drive On) in display Off status, the internal circuits put on the power save mode.

(b) Display Start Line

This instruction set the line address as shown Fig. 1. The selected line in the Display Data RAM correspond to the COM₀ which display at the top of LCD panel.

The display area is set automatically from the selected line to the line which increased the number of duty ratio. Therefore, the smooth scroll for vertical direction by changing the start line address one by one or page switching are available by this instruction.

	A0	\overline{RD}	R/W WR	D ₇	D ₆	D ₅	D ₄	D ₃	D ₂	D ₁	D ₀
Code	0	1	0	1	1	0	A ₄	A ₃	A ₂	A ₁	A ₀

A ₄	A ₃	A ₂	A ₁	A ₀	Line Address
0	0	0	0	0	0
0	0	0	0	1	1
1	1	1	1	0	1E
1	1	1	1	1	1F

(c) Page Address Set

When MPU access the Display Data RAM, the page address corresponded to the row address must be selected. The access in the Display Data RAM is available by setting the page and column address. (Refer the Fig. 1.) The display is no change when the page address is changed.

	A0	\overline{RD}	R/W WR	D ₇	D ₆	D ₅	D ₄	D ₃	D ₂	D ₁	D ₀
Code	0	1	0	1	0	1	1	1	0	A ₁	A ₀

A ₁	A ₀	Page
0	0	0
0	1	1
1	0	2
1	1	3

(d) Column Address Set

This instruction set the column address in the Display Data RAM. (See Fig.1.)

When the MPU access the Display Data RAM continuously, the column address increase "1" automatically, therefore, the MPU can access the data only without address setting.

The increment of the column address is stopped by the address of 50H automatically, but the page address is no change even if the column address increase to 50H and stop.

Code	R/W		D ₇	D ₆	D ₅	D ₄	D ₃	D ₂	D ₁	D ₀
	A ₀	\overline{RD} / WR								
	0	1	0	A ₆	A ₅	A ₄	A ₃	A ₂	A ₁	A ₀

A ₆	A ₅	A ₄	A ₃	A ₂	A ₁	A ₀	Column Add.
0	0	0	0	0	0	0	0
0	0	0	0	0	0	1	1
1	0	0	1	1	1	0	4E
1	0	0	1	1	1	1	4F

(e) Status Read

This instruction read out the internal status.

Code	R/W		D ₇	D ₆	D ₅	D ₄	D ₃	D ₂	D ₁	D ₀
	A ₀	\overline{RD} / WR								
	0	0	1	BUSY	ADC	ON/OFF	RESET	0	0	0

BUSY : BUSY=1 indicate the operating or the Reset cycle.

The instruction can be input after the BUSY status change to "0".

ADC : Indicate the output correspondence of column(segment) address and segment driver.

0 : Counterclockwise Output(Inverse) Column Address 79-n ↔ Segment Driver n

1 : Clockwise Output (Normal) Column Address n ↔ Segment Driver n

ON/OFF : Indicate the whole display On/Off status.

0 : Whole Display "On"

1 : Whole Display "Off"

(Note) The data "0=On" and "1=Off" of Display On/Off status read out is inverted with the Display On/Off instruction data of "1=On" and "0=Off".

RESET : Indicate the initialization period by RST signal or reset instruction.

0 : -|

1 : Initialization Period

(f) Display Data Write

This instruction write the 8-bit data on the data bus into the Display Data RAM.

The column(segment) address increase "1" automatically when writing, therefore, the MPU can write the 8-bit data into the Display Data RAM without address setting.

Code	R/W		D ₇	D ₆	D ₅	D ₄	D ₃	D ₂	D ₁	D ₀
	A ₀	\overline{RD} / WR								
	1	1	0	Write Data						

(g) Display Data Read

This instruction read out the 8-bit data from Display Data RAM which addressed by the column and page address. In case of the Read Modify Write Mode is Off, the column address increase "1" automatically after each read out, therefore, the MPU can read out the 8-bit data from the Display Data RAM continuously without address setting.

One time of dummy read must be required after column address set as explain in (4-3).

	A0	\overline{RD}	R/W \overline{WR}	D ₇	D ₆	D ₅	D ₄	D ₃	D ₂	D ₁	D ₀
Code	1	0	1	R e a d D a t a							

(h) ADC Select

This instruction set the correspondence of column address in the Display Data RAM and segment driver output. (See Fig. 1.) Therefore, the order of segment output can be changed by the software, and no restriction of the LSI placement against the LCD panel.

	A0	\overline{RD}	R/W \overline{WR}	D ₇	D ₆	D ₅	D ₄	D ₃	D ₂	D ₁	D ₀
Code	0	1	0	1	0	1	0	0	0	0	D

D 0 : Clockwise Output (Inverse)
 1 : CounterClockwise Output (Normal)

(i) Static Drive On/Of

This instruction executes the all common output turns on and whole display on obligatory.

	A0	\overline{RD}	R/W \overline{WR}	D ₇	D ₆	D ₅	D ₄	D ₃	D ₂	D ₁	D ₀
Code	0	1	0	1	0	1	0	0	1	0	D

D 0 : Static Drive Off (Normal Operation)
 1 : Static Drive On (Whole Display Turns On)

When the Display Off mode is selected (Display Off) in Static Drive On status, the internal circuits put on the power save mode.

(j) Duty Select

This instruction set the LCD driving duty ratio.

	A0	\overline{RD}	R/W \overline{WR}	D ₇	D ₆	D ₅	D ₄	D ₃	D ₂	D ₁	D ₀
Code	0	1	0	1	0	1	0	1	0	0	D

D 0 : 1/16 duty
 1 : 1/32 duty

(k) Read Modify Write

After this instruction is executed, the column address increase "1" automatically when Display Data Write Instruction execution, but it is not changed when the Display Data Read Instruction execution. This status continues during End instruction execution. When the End instruction is entered the column address back to the address where Read Modify Write instruction entering. By this function, the load of MPU for example cyclic data writing operation like as cursor blink etc., can be reduced.

	R/W										
Code	A0	\overline{RD}	\overline{WR}	D ₇	D ₆	D ₅	D ₄	D ₃	D ₂	D ₁	D ₀
	0	1	0	1	1	1	0	0	0	0	0

Note) During the Read Modify Write mode, any instruction except Column Address Set can be executed.

(l) Sequence of cursor display

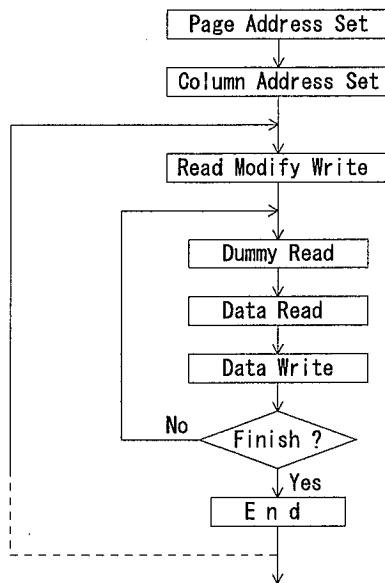

(m) End

This instruction release the Read Modify Write mode and the column address back to the address where the read modify write mode setting.

	R/W										
Code	A0	\overline{RD}	\overline{WR}	D ₇	D ₆	D ₅	D ₄	D ₃	D ₂	D ₁	D ₀
	0	1	0	1	1	1	0	1	1	1	0

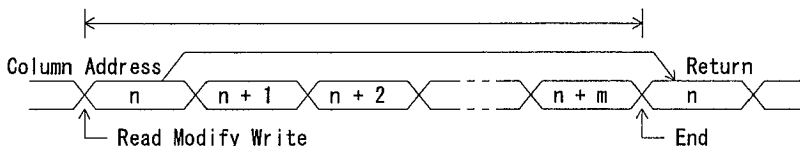

(n) Reset

This instruction executes the following initialization.

Initialization

- 1, Set the 1st line in the Display Start Line Register.
- 2, Set the page 3 in the Page Register.

In this time, there are no influence to the Display Data RAM.

Code	R/W										
	A0	\overline{RD}	\overline{WR}	D ₇	D ₆	D ₅	D ₄	D ₃	D ₂	D ₁	D ₀
	0	1	0	1	1	1	0	0	0	1	0

The reset signal input to the RST terminal must be required for the initialization when the power turns on.

(Note) The initialization when the power turns on can not be executed by Reset instruction.

(o) Power Save(Dual Command)

When both of Display Off and Static Drive On are executed, the internal circuits put on the power save mode and the current consumption is reduced as same as stand by current.

The internal status in this mode are as follows;

- 1, Stop the LCD driving. Segment and Common drivers output V_{DD} level.
- 2, Stop the oscillation or inhibit the external clock input. Then the terminal OSC₂ becomes floating status.
- 3, Keeping the display data and operating mode.

The power save mode is released by Display on or static drive off instruction.

To reduce the total power consumption, the current flow on the bleeder resistance must be cut by the transistor etc. during the power save mode as shown below.

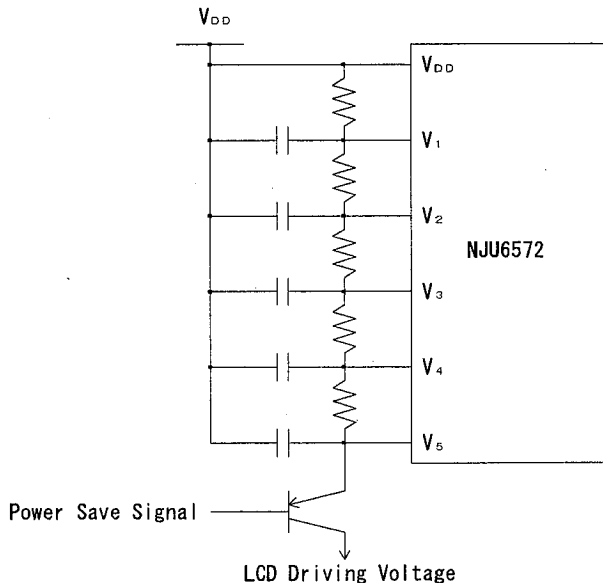

(4) MPU Interface

(4-1) 68 or 80 type MPU interface selection.

The NJU6572 can interface both of 68 or 80 type MPU bus directly by setting the RST level after reset instruction entered as shown Table. 2.

The data transfer is executed between D0 to D7 of NJU6572 and the MPU data bus.

Table. 2.

Level of RST	Type of MPU	A0	E	R/W	D ₀ ~D ₇
"H"	68 type	↑	↑	↑	↑
"L"	80 type	↑	\overline{RD}	\overline{WR}	↑

(4-2) Discrimination of the data bus signal.

The NJU6572 discriminates the data bus signal by combination of A0, E(RD), and R/W(WR) signals as shown Table. 3.

Table. 3.

Common	68 type	80 type		Function
	R/W	\overline{RD}	\overline{WR}	
1	1	0	1	Display Data Read out
1	0	1	0	Display Data Write
0	1	0	1	Status Read
0	0	1	0	Command Input to the Register

(4-3) Access to the Display Data RAM and Internal Register.

The NJU6572 is operating as one of Pipe-line processor by the bus-holder connecting to the internal data bus to adjust the operation frequency between MPU and the Display Data RAM or Internal Register.

For example, when the MPU write the data into the Display Data RAM, the data is held in the bus-holder at once then write into the Display Data RAM by next data write cycle.

Therefore high speed data transmission between MPU and NJU6572 is available because of the limitation of access time of NJU6572 looking from MPU is just determined by the cycle time only which ignored the access time of t_{acc} and t_{ds} of Display Data RAM.

If the cycle time can not be kept in the MPU operation, NOP operation cycle must be insert which equivalent to the waiting operation.

Please note that the read out data is a address data when the read out execution just after the address setting. Therefore, one dummy read must be required after address setting or write cycle as shown in Fig. 2.

• Write operation

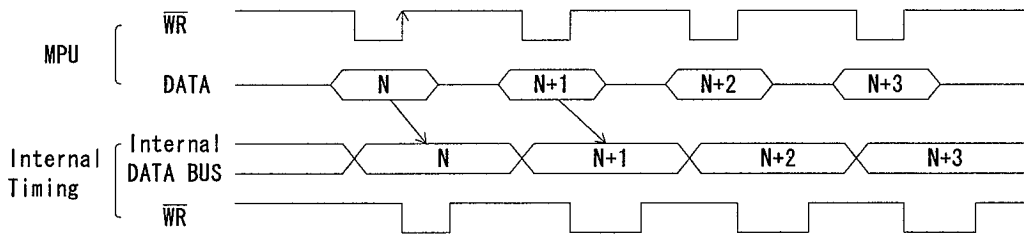

• Read operation

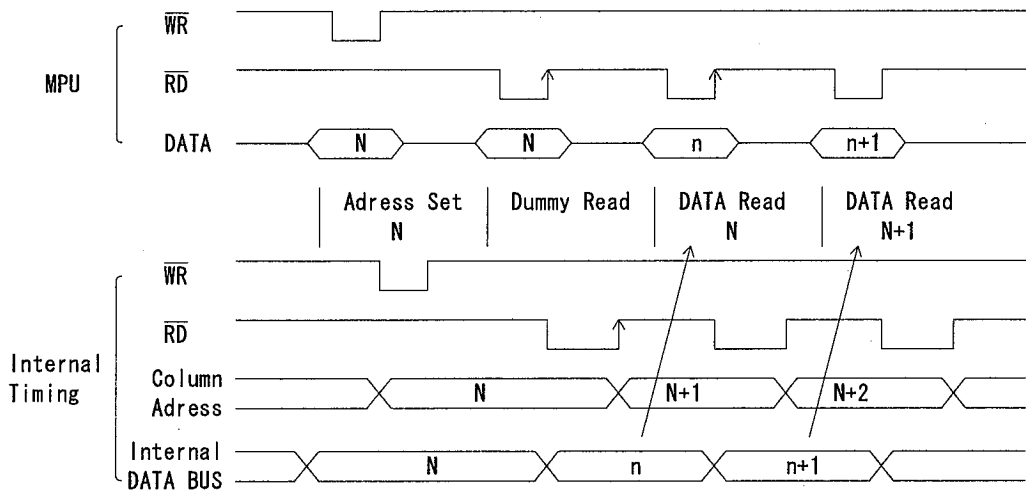

Fig.2 MPU Interface Timing

■ ABSOLUTE MAXIMUM RATINGS

(Ta=25°C)

PARAMETER	SYMBOL	RATINGS	UNIT
Supply Voltage (1)	V _{DD}	- 0.3 ~ + 7.0	V
Supply Voltage (2)	V ₁ ~V ₅ (3)	V _{DD} -11.0 ~ V _{DD} +0.3	V
Input Voltage	V _{IN}	- 0.3 ~ V _{DD} +0.3	V
Operating Temperature	T _{OPR}	- 30 ~ + 80	°C
Storage Temperature	T _{STR}	- 55 ~ + 125	°C

Note 1) If the LSI are used on condition above the absolute maximum ratings, the LSI may be destroyed. Using the LSI within electrical characteristics is strongly recommended for normal operation. Use beyond the electric characteristics conditions will cause malfunction and poor reliability.

Note 2) All voltage values are specified as V_{SS} = 0 V.

Note 3) The relation : V_{DD} ≥ V₁ ≥ V₂ ≥ V₃ ≥ V₄ ≥ V₅ must be maintained.

■ ELECTRICAL CHARACTERISTICS

(V_{DD}=5V±10%, V_{SS}=0V, Ta=-20~+75°C)

PARAMETER		SYMBOL	CONDITIONS	MIN	TYP	MAX	UNIT	Note
Operating Voltage (1)	Recommend	V _{DD}		4.5	5.0	5.5	V	4
	Available			2.4		5.5		
Operating Voltage (2)	Recommend	V ₅	V _{LCD} =V _{DD} -V ₅	V _{DD} -10		V _{DD} -3.5	V	
	Available			V _{DD} -10				
	Available	V ₁ , V ₂		V _{DD} -0.6xV _{LCD}		V _{DD}		
	Available	V ₃ , V ₄		V ₅		V _{DD} -0.4xV _{LCD}		
Input Voltage	1	V _{IHT}	CS, AO, D ₀ ~D ₇ , E, R/W Terminals	2.0		V _{DD}	V	
		V _{ILT}		V _{SS}		0.8		
	2	V _{IHC}	CL, FR, $\overline{\text{RST}}$ Terminals	0.8xV _{DD}		V _{DD}		
		V _{ILC}		V _{SS}		0.2xV _{DD}		
Output Voltage		V _{OHT}	D ₀ ~D ₇ Terminals	I _{OH} =-3.0mA	2.4		V	
		V _{OLT}		I _{OL} = 3.0mA		0.4		
	1	V _{OHC1}	FR Terminal	I _{OH} =-2.0mA	2.4			
		V _{OLC1}		I _{OL} = 2.0mA		0.4		
Input Leakage Current		I _{L1}	AO, E, R/W, CS, CL, $\overline{\text{RST}}$	-1.0		1.0	μA	5
		I _{L0}	D ₀ ~D ₇ , FR Terminals	-3.0		3.0		
Driver On-resistance		R _{ON}	SEG, COM Term Ta=25°C	V _S =V _{DD} -5.0V V _S =V _{DD} -3.5V	5.0	7.5	kΩ	6
Stand-by Current		I _{DD0}	M/S=V _{SS} , OSC ₂ =FR=V _{DD}		0.05	1.0	μA	
Operating Current		I _{DD1}	Display V _S =0V, f _{CL} =2KHz		2.0	5.0	μA	7
		I _{DD2}	Accessing, t _{cy} =200KHz		300	500		
Reset time		t _r	$\overline{\text{RST}}$ Terminal	1.0		1000	us	

Note 4) NJU6572 can operate wide operating range, but it is not guarantee immediate voltage changing during the accessing of the MPU.

Note 5) Apply to the High-impedance state of D_0 to D_7 and FR terminals.

Note 6) R_{ON} is the resistance values between power supply terminals(V_1, V_2, V_3, V_4) and each output terminals of common and segment supplied by 0.1V.

Note 7) The I_{DD2} is specified under the condition of cyclic(t_{cyc})inverted data input cont inuously.
The operating current during the accessing is proportionate to the frequency of t_{cyc} .
In the no accessing it is as same as I_{DD1} .

■ BUS TIMING CHARACTERISTICS

• Read / Write operation sequence (68 Type MPU)

($V_{DD}=5.0V \pm 10\%$, $V_{SS}=0V$, $T_a=-20 \sim +75^\circ C$)

PARAMETER		SYMBOL	MIN	MAX	CONDITION	UNIT
Address Set Up Time	AO, R/W Terminals	t_{AW6}	20			ns
Address Hold Time		t_{AH6}	10			
System Cycle Time		t_{CYC6}	1000			
Enable Pulse Width	E Terminal	t_{EW}	100			
			80			
Data Set Up Time	$D_0 \sim D_7$ Terminals	t_{DS6}	80			
Data Hold Time		t_{DH6}	10			
Access Time		t_{ACC6}		90		
Output Disable Time		t_{CH6}	0	60	$C_L=100pF$	

Note 8) Input signal rise time(t_r) and fall time(t_f) are less than 15ns.

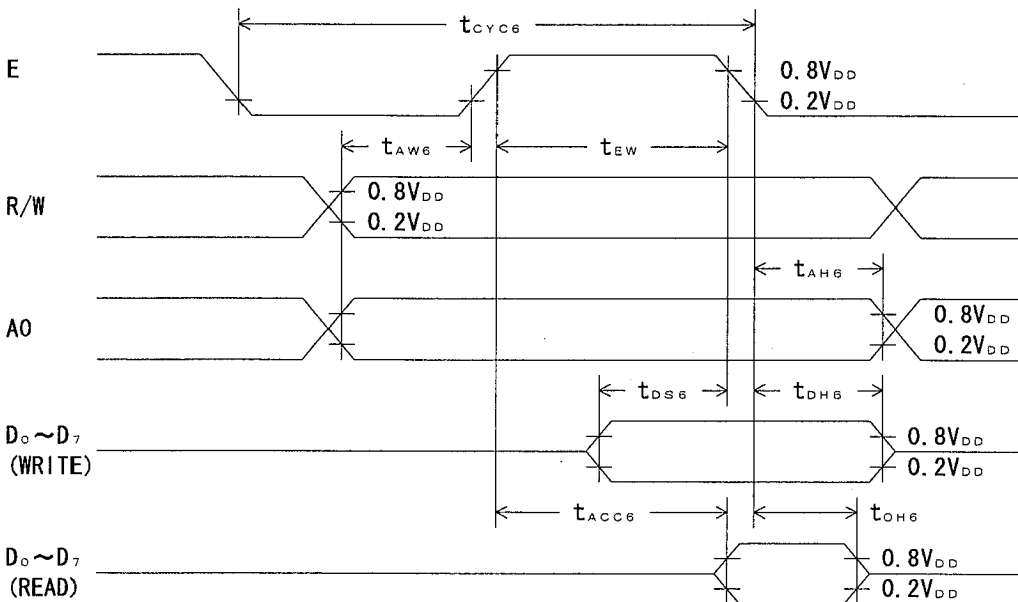

fig. 3 Bus Read / Write operation sequence (68 Type MPU)

•Read / Write operation sequence (80 Type MPU)

($V_{DD}=5.0V \pm 10\%$, $V_{SS}=0V$, $T_a=-20 \sim +75^\circ C$)

PARAMETER		SYMBOL	MIN	MAX	CONDITION	UNIT
Address Set Up Time	A0	t_{AWB}	20			ns
Address Hold Time	Terminal	t_{AHB}	10			
System Cycle Time	\overline{RW} , \overline{WR}	t_{CYCB}	1000			
Control Pulse Width	Terminals	t_{CC}	200			
Data Set Up Time	$D_0 \sim D_7$	t_{DSB}	80			
Data Hold Time		t_{DHB}	10			
RD Access Time		Terminals	t_{ACCB}			
Output Disable Time		t_{CHB}	0	60	$C_L=100pF$	

Note 9) Input signal rise time(t_r) and fall time(t_f) are less than 15ns.

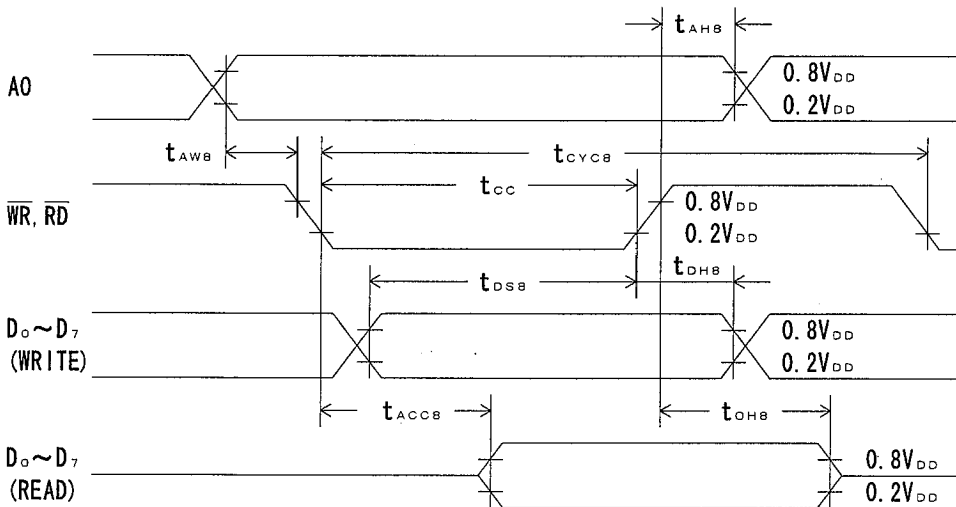

fig.4 Bus Read / Write operation sequence (80 Type MPU)

•Display control timing characteristics (Both of 68 and 80 type MPU)

Input Timing

($V_{DD}=5.0V \pm 10\%$, $V_{SS}=0V$, $T_a=-20 \sim +75^\circ C$)

PARAMETER	SYMBOL	MIN	TYP	MAX	CONDITION	UNIT
"L" level Pulse Width	$t_{W_{LOSC2}}$	35				us
"H" level Pulse Width	$t_{W_{HOSC2}}$	35				
Rise Time	t_r		30	150		ns
Fall Time	t_f		30	150		
FR Delay Time (NJU6572 Slave)	t_{DFR}	-2.0		2.0		us

Output Timing

PARAMETER	SYMBOL	MIN	TYP	MAX	CONDITION	UNIT
FR Delay Time (NJU6572 Master)	t_{DFR}		0.2	0.4	$C_L=100pF$	us

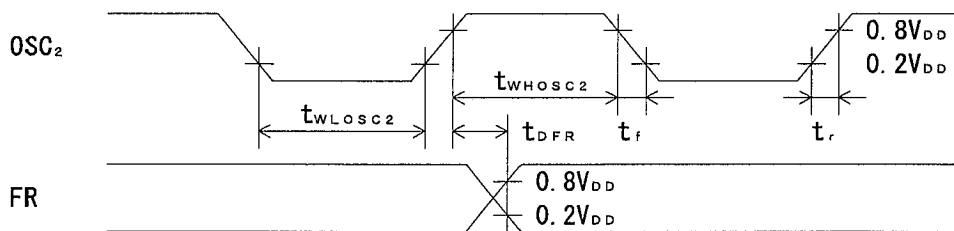
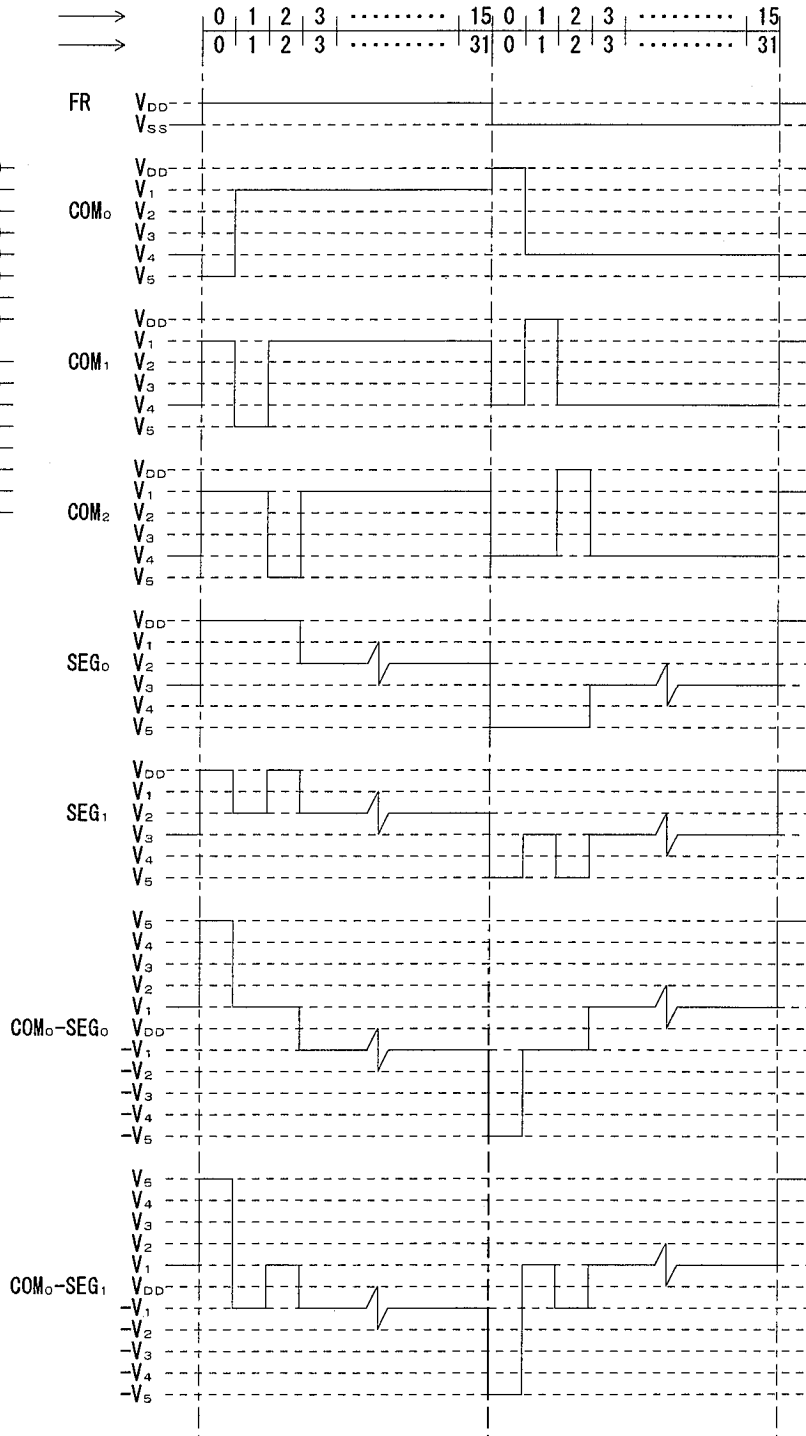
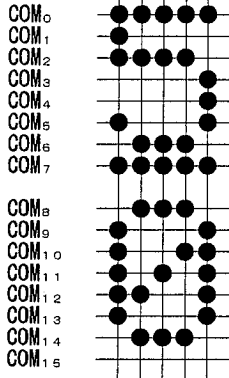

fig.5 Display control timing characteristics

■ LCD DRIVING WAVEFORM

1/5 BIAS, 1/16 DUTY
1/6 BIAS, 1/32 DUTY



APPLICATION CIRCUITS 1

• 68 type MPU Interface

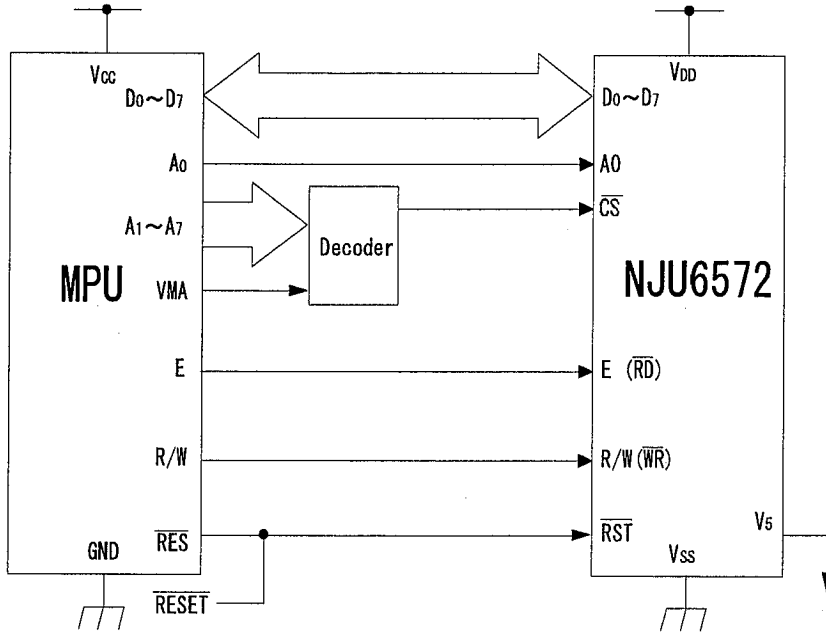

• 80 type MPU Interface

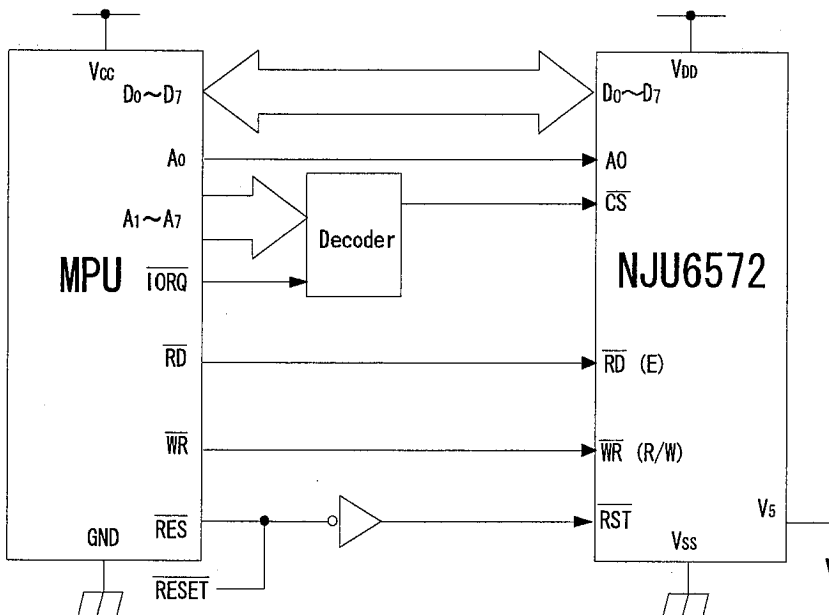

APPLICATION CIRCUITS 2

(1) 16 x 61 dots Driving Application Circuits (NJU6572 Single Operation)

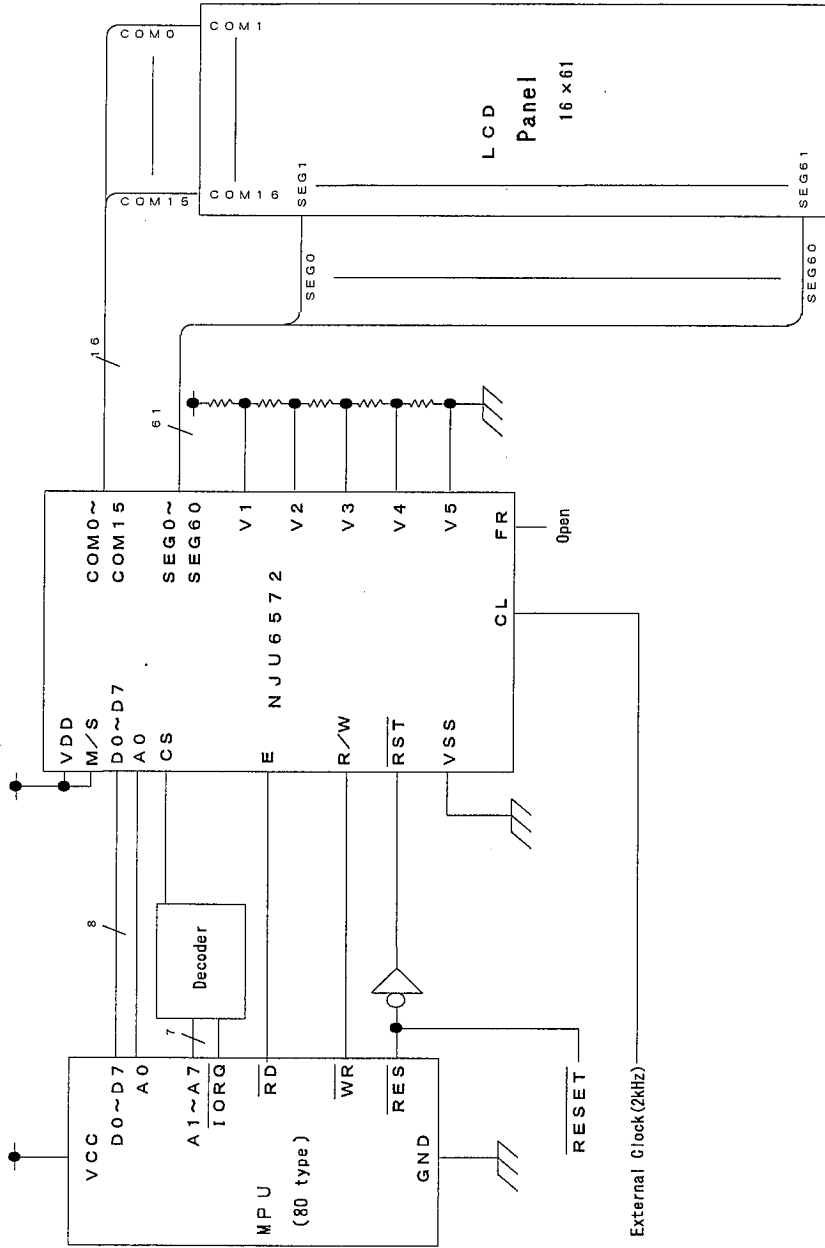

(2) 32 x 122 dots Driving Application Circuits

(Common and Segment Drivers Extension by using two of NJU6572)

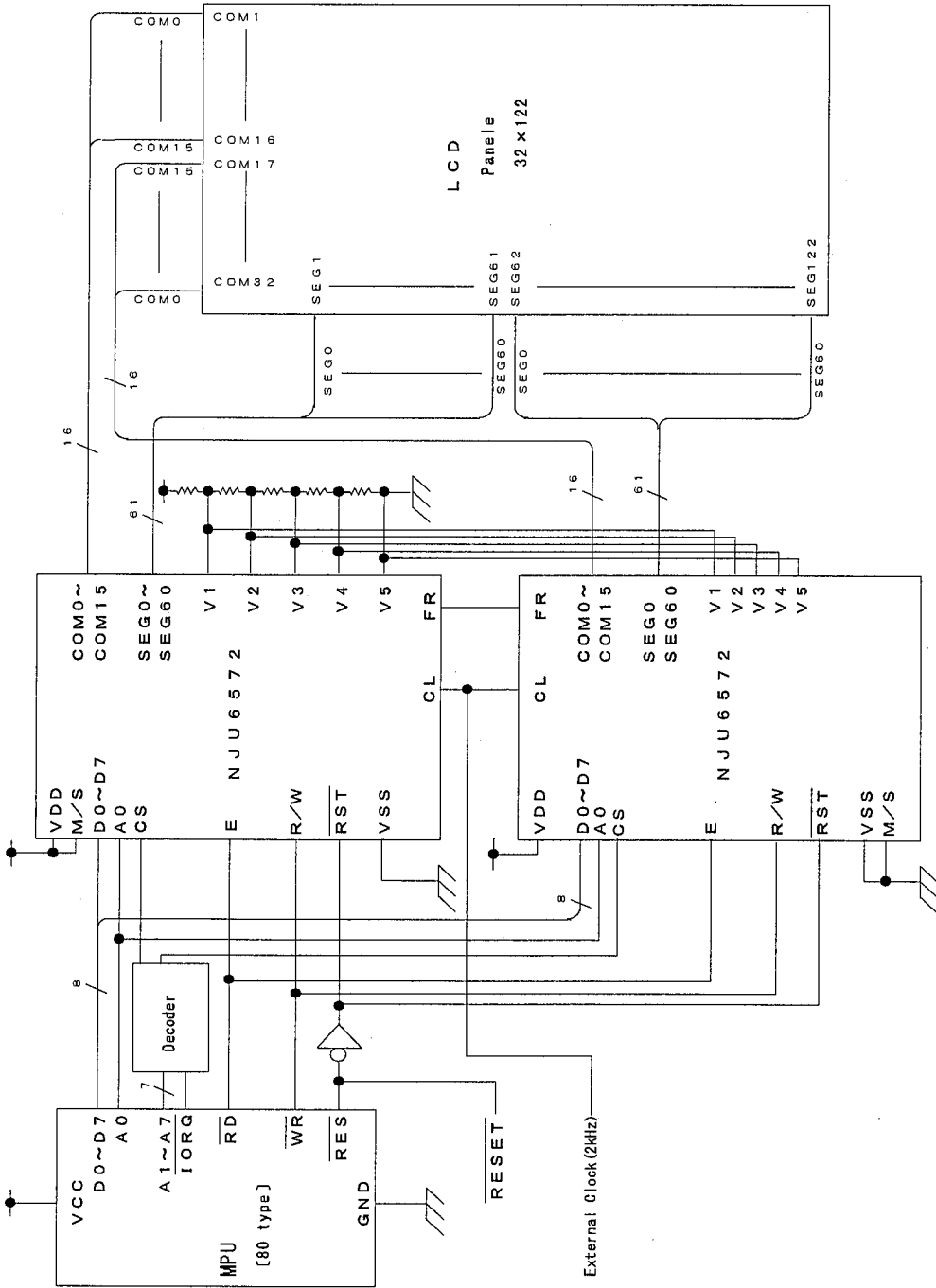

(3) 16 x 141 dots Driving Application Circuits
 (Segment Drivers Extension by using NJU6453A)

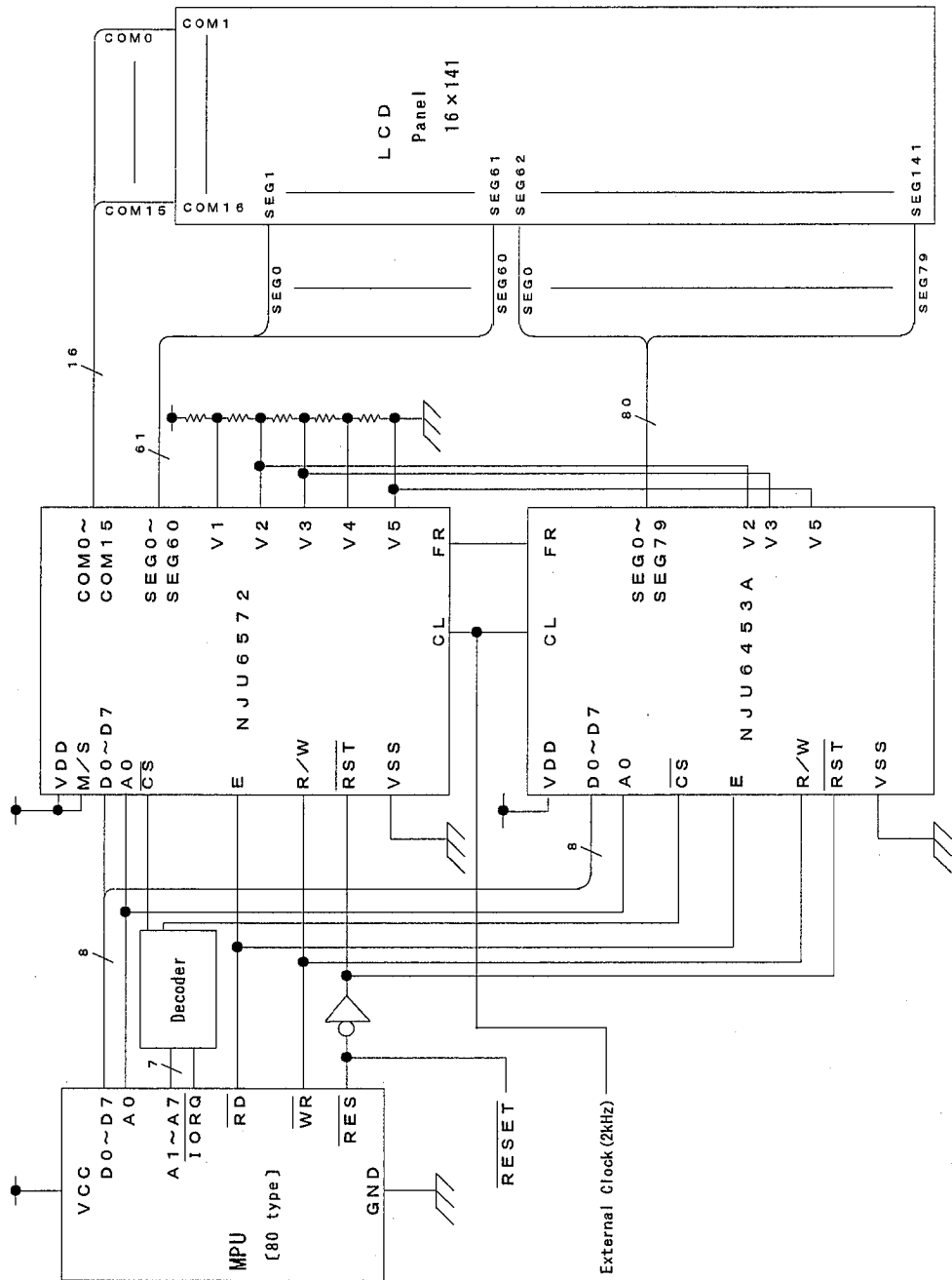

MEMO

[CAUTION]

The specifications on this databook are only given for information, without any guarantee as regards either mistakes or omissions. The application circuits in this databook are described only to show representative usages of the product and not intended for the guarantee or permission of any right including the industrial rights.