

FEATURES

28/56-bit, 25 MHz digital audio processor

Stereo ADC: 102 dB dynamic range and -90 dB THD+N

4-channel DAC: 103 dB dynamic range and -90 dB THD+N

Complete stand-alone operation

- Self-boot from serial EEPROM
- Auxiliary ADC with four-input mux for analog control
- GPIOs for digital controls and outputs

Fully programable with SigmaStudio™ graphical tool

Sampling rates up to 192 kHz supported

28-bit × 28-bit multiplier with 56-bit accumulator

Double precision mode for full 56-bit processing

Clock Oscillator for generating master clock from crystal

PLL for generating master clock from $64 \times f_s$, $256 \times f_s$, $384 \times f_s$, or $512 \times f_s$ clocks

Flexible serial data I/O ports with I²S compatible, left-justified, right-justified, and TDM serial port modes

On-chip voltage regulator for compatibility with 3.3 V systems

48-lead LQFP plastic package

GENERAL DESCRIPTION

The ADAU1702 is a stand-alone 28/56-bit audio DSP which handles all system processing and control tasks. Processing includes equalization, crossover, bass enhancement, multiband dynamics processing, delay compensation, speaker compensation, and stereo image widening. These algorithms can be used to compensate for the real-world limitations of speakers, amplifiers, and listening environments, resulting in a dramatic improvement of perceived audio quality.

The signal processing used in the ADAU1702 is comparable to that found in high end studio equipment. Most of the processing is done in full 56-bit double-precision mode, resulting in very good low level signal performance. The ADAU1702 is a fully-programmable DSP. The easy-to-use SigmaStudio software allows the user to graphically configure a custom signal processing flow using blocks such as biquad

Rev. PrC

Information furnished by Analog Devices is believed to be accurate and reliable. However, no responsibility is assumed by Analog Devices for its use, nor for any infringements of patents or other rights of third parties that may result from its use. Specifications subject to change without notice. No license is granted by implication or otherwise under any patent or patent rights of Analog Devices. Trademarks and registered trademarks are the property of their respective owners.

APPLICATIONS

Multimedia audio speaker systems

MP3 player speaker docks

Automotive head units

Mini-component stereos

Digital televisions

Studio monitors

Speaker crossover

Musical instrument effects boxes

In-seat sound systems (aircrafts/motor coaches)

FUNCTIONAL BLOCK DIAGRAM

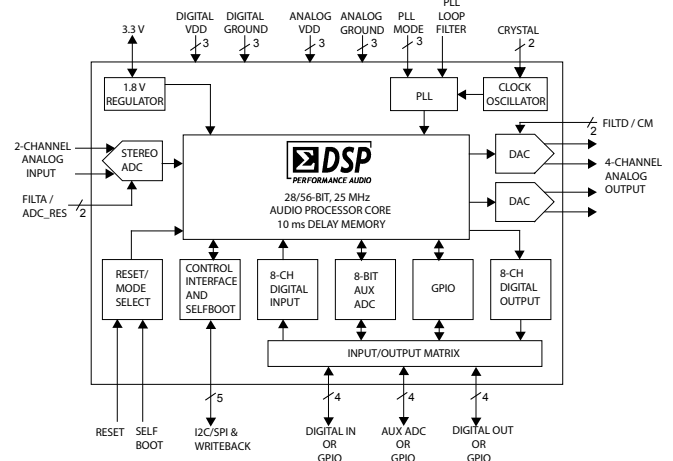

Figure 1.

filters, dynamics processors, level controls, and GPIO interface controls.

ADAU1702 programs can be loaded on power-up either from a serial EEPROM though its own self-boot mechanism or from an external microcontroller. On power-down, the current state of the parameters can be written back to the EEPROM from the ADAU1702 to be recalled the next time the program is run.

The ADAU1702's two ADCs and four DACs provide an analog-in to analog-out dynamic range greater than 98 dB and THD+N better than -92 dB. Digital input and output ports allow a glueless connection to additional ADCs and DACs. The ADAU1702 operates with either an I²C bus or a 4-wire SPI port.

TABLE OF CONTENTS

Introduction	3	Recommended Program/Parameter Loading Procedure	22
Specifications.....	4	Safeload Registers	22
Analog Performance	4	Data Capture Registers	22
Digital I/O	5	DSP Core Control Register	23
Power.....	5	Interface Registers	23
Temperature Range	5	Control Port Read/Write Data Formats	23
Digital Timing.....	5	Multipurpose Pins	26
PLL	6	GPIO pin Setting Register.....	26
Regulator.....	6	Multi-Purpose pin Configuration Registers.....	26
Absolute Maximum Ratings.....	7	Auxiliary ADC.....	26
ESD Caution.....	7	General Purpose Input/Outputs	27
Digital Timing Diagrams.....	8	Serial Data Input/Output Ports	27
Pin Configuration and Function Descriptions.....	10	Serial Output Control Registers	28
Pin Functions	12	Serial Input Control Register	29
Signal Processing	14	Two-Channel Audio ADC	31
Overview.....	14	Four-Channel DAC.....	32
Numeric Formats.....	14	Initialization	33
Programming.....	14	Power-Up Sequence	33
Control Port.....	15	Setting Master Clock/PLL Mode.....	33
Overview.....	15	Voltage Regulator	33
SPI Port	15	Layout Recommendations.....	34
I ² C Port	15	Parts Placement	34
Self boot	18	Grounding.....	34
RAMs and Registers	21	Outline Dimensions	35
Control Port Addressing.....	21	Ordering Guide	35
Parameter RAM.....	21		

REVISION HISTORY

9/05—Preliminary Version PrC1

INTRODUCTION

The core of the ADAU1702 is a 28-bit DSP (56-bit with double precision) optimized for audio processing. The part's program and parameter RAMs can be loaded with a custom audio processing signal flow built with ADI's SigmaStudio graphical programming software. The values stored in the parameter RAM control individual signal processing blocks, such as IIR equalization filters, dynamics processors, audio delays, and mixer levels. A safeload feature allows parameters to be transparently updated without causing clicks on the output signals.

The program RAM, parameter RAM, and register contents can be saved in an external EEPROM, from which the ADAU1702 can self-boot on start-up. In this stand-alone mode, parameters can be controlled through the on-board multipurpose pins. The ADAU1702 can accept controls from switches, potentiometers, rotary encoders, and IR receivers. Parameters such as volume and tone settings can be saved to the EEPROM on power-down and recalled when it is powered up again.

The ADAU1702 can operate with either digital or analog I/Os, or a mix of both. The stereo ADC and four-channel DAC have an analog-to-analog SNR of 97 dB. ... The flexible serial data input/output ports allow for glueless interconnection to a variety of ADCs, DACs, general-purpose DSPs, S/PDIF receivers & transmitters, and sample rate converters. The ADAU1702 can be configured in I²S, left-justified, right-justified, or TDM serial port compatible modes.

Twelve multi-purpose (MP) pins allow for the ADAU1702 to input external control signals and output flags or controls to other devices in the system. These MP pins can be configured as digital I/Os, inputs to the 4-channel auxiliary ADC, or set up as the serial data I/O ports. As inputs, these can be connected to buttons, switches, rotary encoders, potentiometers, IR receivers, or other external control circuitry to control the internal signal processing program. When configured as outputs, these pins can be used to drive LEDs (with a buffer), control other ICs, or connect to other external circuitry in an application.

The ADAU1702 has a sophisticated control port that supports complete read/write capability of all memory locations. Control registers are provided to offer complete control of the chip's configuration and serial modes. Handshaking is included for ease of memory uploads/downloads. The ADAU1702 can be configured for either SPI or I²C control.

An on-board oscillator can be connected to an external crystal to generate the master clock. Also, a master clock phase-locked loop (PLL) allows the ADAU1702 to be clocked from a variety of different clock speeds. The PLL can accept inputs of $64 \times f_s$,

$256 \times f_s$, $384 \times f_s$, or $512 \times f_s$ to generate the core's internal master clock.

The SigmaStudio software is used to program and control the SigmaDSP through the control port. Along with designing and tuning a signal flow, the tools can configure the all registers and burn a new program into the external EEPROM. SigmaStudio's graphical interface allows anyone with digital or analog audio processing knowledge to easily design a DSP signal flow and port it to a target application. It also provides enough flexibility and programmability for an experienced DSP programmer to have in-depth control of the design. In SigmaStudio, the user can simply connect graphical blocks such as biquad filters, dynamics processors, mixers, and delays, compile the design, and load the program and parameter files into the ADAU1702's memory through the control port. Signal processing blocks available in the provided libraries include

- Single- and double-precision biquad filters
- Mono and multichannel dynamics processors with peak or RMS detection
- Mixers and splitters
- Tone and noise generators
- Fixed and variable gain
- Loudness
- Delay
- Stereo enhancement
- Dynamic bass boost
- Noise and tone sources
- Level detectors
- GPIO control & conditioning

More processing blocks are always in development. Analog Devices also provides proprietary and third-party algorithms for applications such as matrix decoding, bass enhancement, and surround virtualizers. Please contact ADI for information about licensing these algorithms.

The ADAU1702 operates from a 1.8 V digital power supply, and a 3.3 V analog supply. An on-board voltage regulator can be used to operate the digital circuitry from a 3.3 supply. It is fabricated on a single monolithic integrated circuit and is housed in a 48-lead LQFP package for operation over the -0°C to $+70^{\circ}\text{C}$ temperature range.

SPECIFICATIONS

Test conditions, unless otherwise noted.

Table 1.

Parameter	Conditions
Analog Supply Voltage (AVDD)	
Digital Supply Voltage (DVDD)	
PLL Voltage (PVDD)	
Output Voltage (IOVDD)	
Ambient Temperature	
Master Clock Input	
Load Capacitance	
Load Current	
Input Voltage, HI	
Input Voltage, LO	

ANALOG PERFORMANCE

Table 2. Analog Performance

Parameter	Min	Typical	Max	Units	Test Conditions/Comments
REFERENCE SECTION					
Absolute Voltage V_{REF}		1.5		V	
V_{REF} Temperature Coefficient		TBD		ppm/°C	
AUX ANALOG INPUTS					
Full Scale Analog Input		3.3		V	
Step size		13		mV	
ADC INPUTS					
Number of channels		2			Stereo ADC
Resolution		24		Bits	
Full Scale Analog Input		100		μ Arms	2Vrms input with 20k Ω series resistor
Signal-to-Noise Ratio					
A-Weighted		100		dB	
Dynamic Range					-60dB with respect to full scale Analog input
A-Weighted		TBD		dB	
Total Harmonic Distortion + Noise		-95		dB	-xxdB with respect to full scale Analog input
Interchannel Gain Mismatch		TBD		dB	Left and Right channel Gain Mismatch
Crosstalk		TBD		dB	Analog Channel Crosstalk
DC Bias		TBD		V	
Gain Error		TBD		dB	
Power Supply Rejection		TBD		dB	1kHz, 300mV _{P-P} Signal at AVDD
DAC OUTPUTS					
Number of channels		4			2 stereo output channels
Resolution		24		Bits	
Full Scale Analog Output		1		Vrms	
Signal-to-Noise Ratio					
A-Weighted		105		dB	
Dynamic Range					-60dB with respect to full scale Analog input
A-Weighted		TBD		dB	
Total Harmonic Distortion + Noise		-95		dB	-xxdB with respect to full scale Analog input
Crosstalk		TBD		dB	Analog Channel Crosstalk
Interchannel Gain Mismatch		TBD		dB	Left and Right channel Gain Mismatch
DC Bias		1.5		V	
Power Supply Rejection		TBD		dB	1kHz, 300mV _{P-P} Signal at AVDD

DIGITAL I/O

Table 3. Digital I/O

Parameter	Min	Max	Unit
Input Voltage, HI (V_{IH})			V
Input Voltage, LO (V_{IL})			V
Input Leakage (I_{IH})			μ A
Input Leakage (I_{IL})			μ A
Low Level Output Voltage (V_{OL}) IOVDD = x.x V, I_{OL} = xx mA			V
Low Level Output Voltage (V_{OL}) IOVDD = x.x V, I_{OL} = xx mA			V
Input Capacitance			pF

POWER

Table 4.

Parameter	Comments	Min	Typ	Max ¹	Unit
Supplies					
Analog Voltage			3.3		V
Digital Voltage			1.8		V
PLL Voltage			3.3		V
Analog Current			TBD		mA
Digital Current			TBD		mA
PLL Current			TBD		mA
Analog Current, Reset			TBD		mA
Digital Current, Reset			TBD		mA
PLL Current, Reset			TBD		mA
Dissipation					
Operation, all supplies			TBD		mW
Reset, all supplies			TBD		mW

¹ Maximum specifications are measured across $-xx^{\circ}$ C to xx° C (case) and across VDD = xxx V to xxx V.

TEMPERATURE RANGE

Table 5.

Parameter	Min	Typ	Max	Unit
Functionality Guaranteed	xx° C		xx° C	$^{\circ}$ C Ambient
	xx° C		xx° C	$^{\circ}$ C Case

DIGITAL TIMING

Table 6 Digital Timing¹

Parameter	Comments	Min	Max	Unit
t_{MP}	MCLK Period			ns
t_{MP}	MCLK Period			ns
t_{MP}	MCLK Period			ns
t_{MP}	MCLK Period			ns
t_{MP}	MCLK Period			ns
t_{MDC}	MCLK Duty Cycle			%
t_{BIL}	BCLK_IN LO Pulse Width			ns
t_{BIH}	BCLK_IN HI Pulse Width			ns
t_{LIS}	LRCLK_IN Setup	To BCLK_IN rising		ns
t_{LIH}	LRCLK_IN Hold	From BCLK_IN rising		ns
t_{SIS}	SDATA_INx Setup	To BCLK_IN rising		ns
t_{SIH}	SDATA_INx Hold	From BCLK_IN rising		ns
t_{LOS}	LRCLK_OUTx Setup	Slave mode		ns
t_{LOH}	LRCLK_OUTx Hold	Slave mode		ns

t _{TS}	BCLK_OUTx Falling to LRCLK_OUTx Timing Skew				ns
t _{SODS}	SDATA_OUTx Delay	Slave mode, from BCLK_OUTx falling			ns
t _{SODM}	SDATA_OUTx Delay	Master mode, from BCLK_OUTx falling			ns
t _{CCPL}	CCLK Pulse Width LO				ns
t _{CCPH}	CCLK Pulse Width HI				ns
t _{CLS}	CLATCH Setup	To CCLK rising			ns
t _{CLH}	CLATCH Hold	From CCLK rising			ns
t _{CLPH}	CLATCH Pulse Width HI				ns
t _{CDS}	CDATA Setup	To CCLK rising			ns
t _{CDH}	CDATA Hold	From CCLK rising			ns
t _{COD}	COU Delay	From CCLK rising			ns
t _{RLPW}	RESETB LO Pulse Width				ns
f _{SCL}	SCL Clock Frequency			TBD	kHz
t _{SCLH}	SCL High		TBD		μs
t _{SCLL}	SCL Low		TBD		μs
t _{SCS}	Setup Time	Relevant for Repeated Start Condition	TBD		μs
t _{SCH}	Hold Time	After this period the 1st clock is generated	TBD		μs
t _{DS}	Data Setup Time		TBD		ns
t _{SCR}	SCL Rise Time			TBD	ns
t _{SCF}	SCL Fall Time			TBD	ns
t _{SDR}	SDA Rise Time			TBD	ns
t _{SDF}	SDA Fall Time			TBD	ns

¹ All timing specifications are given for the default (I²S) states of the serial input control port and the serial output control ports. See Table 40.

PLL
Table 7.

Parameter	Min	Typ	Max	Unit
Lock Time			TBD	ms

REGULATOR
Table 8.

Parameter	Min	Typ	Max	Unit
DVDD Voltage		1.8		V

ABSOLUTE MAXIMUM RATINGS

Table 9.

Parameter	Min	Max	Unit
DVDD to GND			V
AVDD to GND			V
IOVDD to GND			V
Digital Inputs			V
Maximum Junction Temperature		135	°C
Storage Temperature Range	-65	+150	°C
Soldering (10 sec)		300	°C

Stresses above those listed under Absolute Maximum Ratings may cause permanent damage to the device. This is a stress rating only; functional operation of the device at these or any other conditions above those indicated in the operational section of this specification is not implied. Exposure to absolute maximum rating conditions for extended periods may affect device reliability.

Table 10. Package Characteristics

Parameter	Min	Typ	Max	Unit
θ_{JA} Thermal Resistance (Junction-to-Ambient)		72		°C/W
θ_{JC} Thermal Resistance (Junction-to-Case)		19.5		°C/W

ESD CAUTION

ESD (electrostatic discharge) sensitive device. Electrostatic charges as high as 4000 V readily accumulate on the human body and test equipment and can discharge without detection. Although this product features proprietary ESD protection circuitry, permanent damage may occur on devices subjected to high energy electrostatic discharges. Therefore, proper ESD precautions are recommended to avoid performance degradation or loss of functionality.



DIGITAL TIMING DIAGRAMS

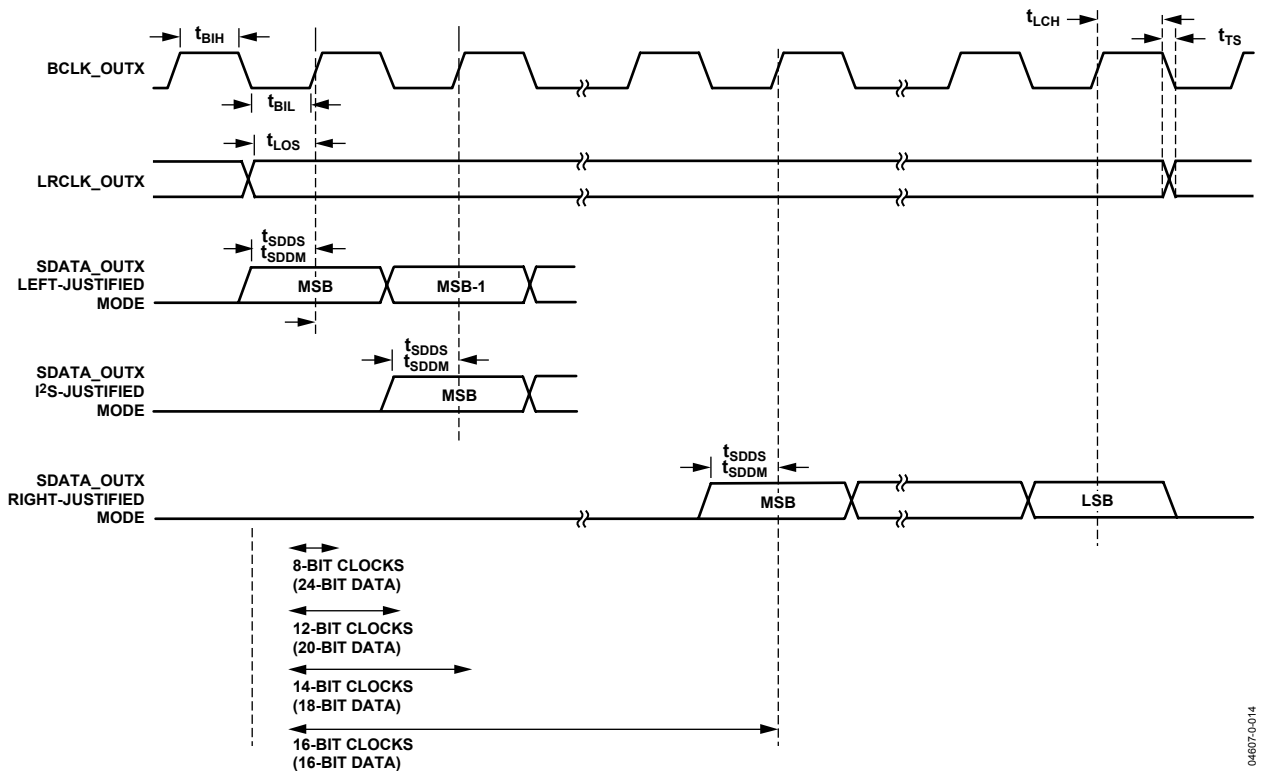
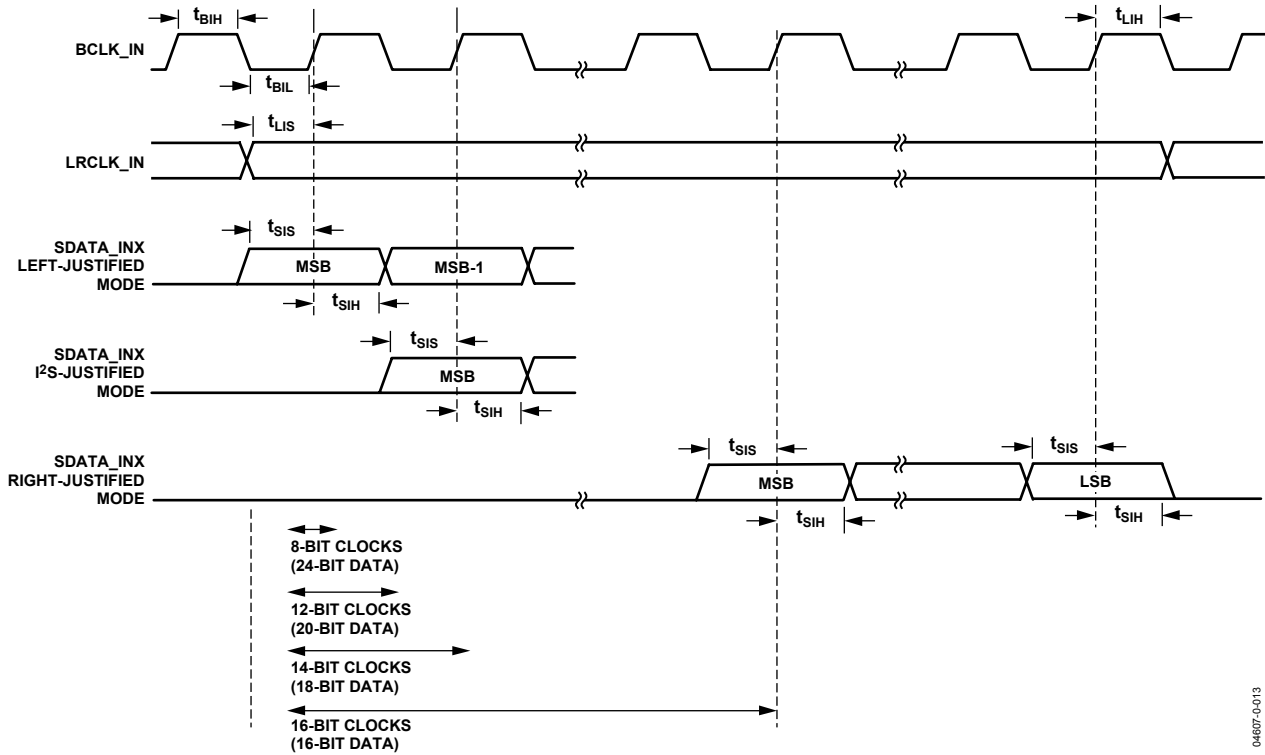

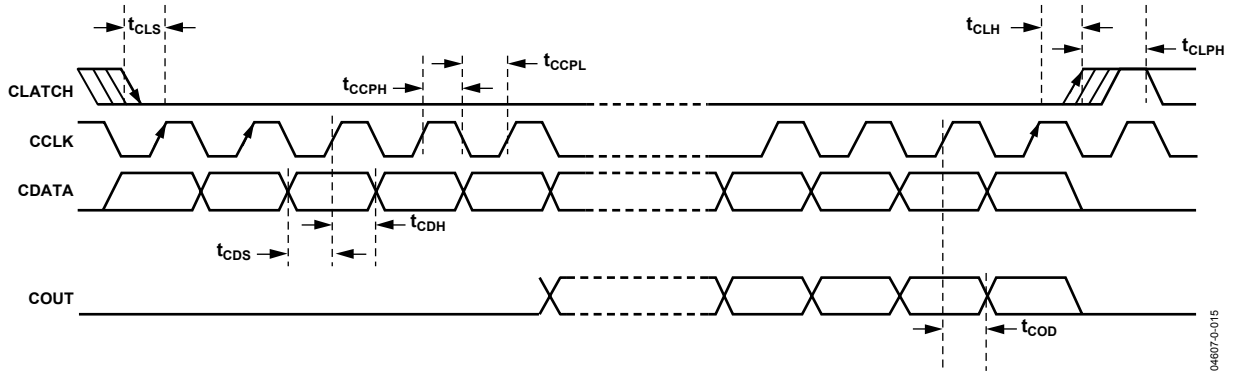

Figure 4. SPI Port Timing

04607-0-015

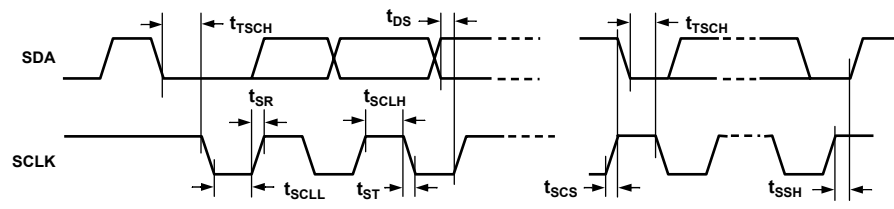

Figure 5. I2C Port Timing

04607-0-028

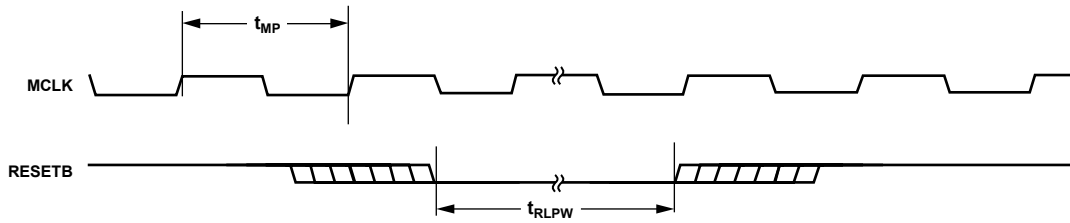

Figure 6. Master Clock and Reset Timing

04607-0-016

PIN CONFIGURATION AND FUNCTION DESCRIPTIONS

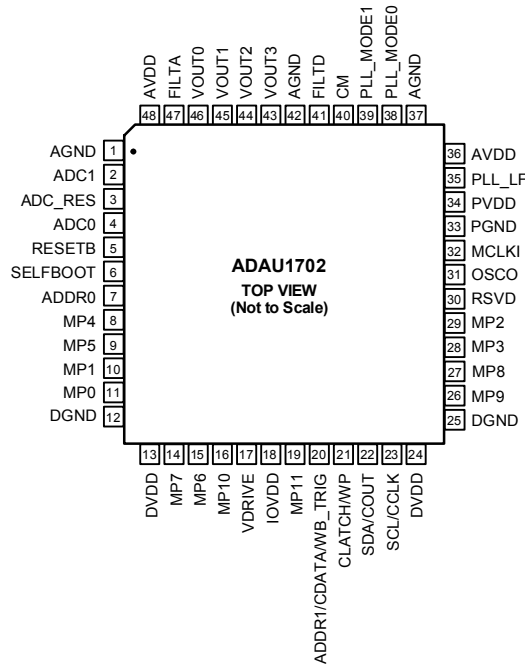

Figure 7. 48-Lead LQFP Pin Configuration

Table 11. Pin Function Descriptions

Pin No.	I/O	Mnemonic	Description
1		AGND	Analog Ground
2	IN	ADC1	Analog input 1
3		ADC_RES	Reference current – connect resistor
4	IN	ADC0	Analog Input 0
5	IN	RESETB	Reset, Active Low
6	IN	SELFBOOT	Select Host or Self-boot mode
7	IN	ADDR0	I ² C and SPI Address 0
8	IN/OUT	MP4	Multi-Purpose – GPIO or Serial input port LRCLK
9	IN/OUT	MP5	Multi-Purpose – GPIO or Serial input port BCLK
10	IN/OUT	MP1	Multi-Purpose – GPIO or Serial Input port data 1
11	IN/OUT	MP0	Multi-Purpose – GPIO or Serial Input port data 0
12		DGND	Digital Ground
13		DVDD	1.8 V Digital Supply
14	IN/OUT	MP7	Multi-Purpose – GPIO or Serial output port data 1
15	IN/OUT	MP6	Multi-Purpose – GPIO, Serial output port data 0, or TDM data output
16	IN/OUT	MP10	Multi-Purpose – GPIO or Serial output port LRCLK
17	OUT	VDRIVE	Drive for external PNP Transistor for 1.8 V regulator
18		IOVDD	Input and Output Pin Supply
19	IN/OUT	MP11	Multi-Purpose – GPIO or Serial output port BCLK
20	IN	ADDR1/CDATA/WB_TRIG	I ² C Address 1 / SPI Data Input / Self-boot Write-back trigger
21	IN/OUT	CLATCH / WP	SPI Latch / Self-boot EEPROM write protect
22	IN/OUT	SDA/COUT	I ² C Data / SPI Data Out
23	IN/OUT	SCL/CCLK	I ² C Clock / SPI Clock
24		DVDD	1.8 V Digital Supply
25		DGND	Digital Ground

26	IN/OUT	MP9	Multi-Purpose – GPIO or Aux ADC input 0
27	IN/OUT	MP8	Multi-Purpose – GPIO or Aux ADC input 3
28	IN/OUT	MP3	Multi-Purpose – GPIO or Aux ADC input 2
29	IN/OUT	MP2	Multi-Purpose – GPIO or Aux ADC input 1
30		RSVD	Reserved, tie to ground
31	OUT	OSCO	Oscillator Output
32	IN	MCLKI	Master Clock or Crystal Input
33		PGND	PLL Ground
34		PVDD	3.3 V PLL Power
35		PLL_LF	PLL Loop Filter connection
36		AVDD	3.3 V Analog Supply
37		AGND	Analog Ground
38	IN	PLL_MODE0	PLL Mode select 0
39	IN	PLL_MODE1	PLL Mode select 1
40		CM	Common Mode Decoupling Capacitor
41		FILTD	Decoupling Capacitor
42		AGND	Analog Ground
43	OUT	VOUT3	Channel 3 DAC output
44	OUT	VOUT2	Channel 2 DAC output
45	OUT	VOUT1	Channel 1 DAC output
46	OUT	VOUT0	Channel 0 DAC output
47		FILTA	Decoupling capacitor
48		AVDD	3.3 V Analog Supply

PIN FUNCTIONS

Table 11 shows the ADAU1702's pin numbers, names, and functions. Input pins have a logic threshold compatible with TTL input levels and may be used in systems with 3.3 V logic.

ADC0

ADC1

Stereo ADC inputs.

IDAC

Bias current pin for ADC. A resistor with the same value as those on the ADC0 & ADC1 should be connected between this pin and ground.

FILTA

ADC decoupling pin. A 10 μ F capacitor should be placed between this pin and ground.

VOUT0

VOUT1

VOUT2

VOUT3

Four-channel DAC outputs

CM

Reference. A 47 μ F capacitor should be placed between this pin and ground to reduce crosstalk.

FILTD

DAC decoupling pin. A 10 μ F capacitor should be placed between this pin and ground.

PLL_MODE0

PLL_MODE1

PLL_MODE2

PLL Mode Control Pins. The functionality of these pins is described in the Setting Master Clock/PLL Mode section.

MCLKI

Master clock or crystal oscillator input.

OSCO

Crystal oscillator output.

PLL_LF

PLL loop filter connection.

SCL

I²C Clock. This pin is always an input when in I²C control mode. In self-boot mode this pin will be an output (I²C master). The line connected to this pin should have a 2 k Ω pull-up resistor on it.

SDA

I²C Serial Data. The data line is bidirectional. The line connected to this pin should have a 2 k Ω pull-up resistor on it.

CDATA

Serial Data Input for the SPI Control Port.

COUT

Serial Data Output for the SPI Port. This is used for reading back registers and memory locations. It is three-stated when an SPI read is not active.

CCLK

SPI Bit Clock. This clock may either run continuously or be gated off in between SPI transactions.

CLATCH

SPI Latch Signal. This must go low at the beginning of an SPI transaction and high at the end of a transaction. Each SPI transaction may take a different number of CCLKs to complete, depending on the address and read/write bit that are sent at the beginning of the SPI transaction.

ADDR0

ADDR1

Address Select. These pins select the address for the ADAU1702's communication with the control port. This allows two ADAU1702s to be used on the same control port.

WP

EEPROM write protect.

WB_TRIG

EEPROM Writeback trigger.

RESETB

Active-Low Reset Signal. After RESETB goes high, the ADAU1702 goes through an initialization sequence where the program and parameter RAMs are initialized with the contents of the on-board boot ROMs. All registers are set to 0, and the data RAMs are also set to 0. The initialization is complete after xxxx internal MCLK cycles (referenced to the rising edge of RESETB), which corresponds to xxxx external MCLK cycles if the part is in $256 \times f_s$ mode. New values should not be written to the control port until the initialization is complete.

SELBOOT

Selfboot or external program load select.

MP0

MP1

MP2

MP3

MP4

MP5

MP6

MP7

MP8

MP9

MP10

MP11

Multi-purpose input/output pins. These pins can be configured as serial data inputs/outputs, auxiliary ADC inputs, or general purpose switch and button inputs/outputs.

AVDD

Analog VDD for Core. 3.3 V nominal.

AGND

Analog Ground.

DVDD

Digital VDD for Core. 1.8 V nominal.

DGND

Digital Ground.

IOVDD

Input and Output pins supply.

PVDD

PLL and aux ADC supply.

PGND

PLL and aux ADC ground.

VDRIVE

Drive for External Transistor. The base of the voltage regulator's external PNP transistor is driven from this pin.

RSVD

This pin should be tied to ground.

SIGNAL PROCESSING

OVERVIEW

The ADAU1702 is designed to provide all signal processing functions commonly used in stereo or multichannel playback systems. The signal processing flow is designed using the ADI-supplied SigmaStudio software, which allows graphical entry and real-time control of all signal processing functions.

Many of the signal processing functions are coded using full, 56-bit double-precision arithmetic. The input and output word lengths are 24 bits. Four extra headroom bits are used in the processor to allow internal gains up to 24 dB without clipping. Additional gains can be achieved by initially scaling down the input signal in the signal flow.

The signal processing blocks can be arranged in a custom program that can be loaded to the ADAU1702's RAM. The available signal processing blocks are explained in the following sections.

NUMERIC FORMATS

It is common in DSP systems to use a standardized method of specifying numeric formats. Fractional number systems are specified by an A.B format, where A is the number of bits to the left of the decimal point and B is the number of bits to the right of the decimal point.

The ADAU1702 uses the same numeric format for both the coefficient values (stored in the parameter RAM) and the signal data values. The format is as follows:

Numerical Format: 5.23

Range: -16.0 to (+16.0 - 1 LSB)

Examples:

1000 0000 0000 0000 0000 0000 = -16.0

1110 0000 0000 0000 0000 0000 = -4.0

1111 1000 0000 0000 0000 0000 = -1.0

1111 1110 0000 0000 0000 0000 = -0.25
 1111 1111 1111 1111 1111 1111 = (1 LSB below 0.0)
 0000 0000 0000 0000 0000 0000 = 0.0
 0000 0010 0000 0000 0000 0000 = 0.25
 0000 1000 0000 0000 0000 0000 = 1.0
 0010 0000 0000 0000 0000 0000 = 4.0
 0111 1111 1111 1111 1111 1111 = (16.0 - 1 LSB).

The serial port accepts up to 24 bits on the input and is sign-extended to the full 28 bits of the core. This allows internal gains of up to 24 dB without encountering internal clipping.

A digital clipper circuit is used between the output of the DSP core and the outputs (see Figure 8). This clips the top four bits of the signal to produce a 24-bit output with a range of 1.0 (minus 1 LSB) to -1.0.

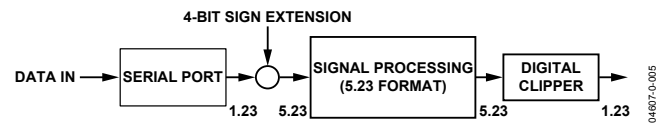

Figure 8. Numeric Precision and Clipping Structure

PROGRAMMING

On power-up, the ADAU1702's default program passes the unprocessed input signals to the outputs (Figure 22) but the outputs are muted by default (see Power-Up Sequence section). There are 512 instruction cycles per audio sample. This DSP runs in a stream-oriented manner, meaning all 512 instructions are executed each sample period. The ADAU1702 may also be set up to accept double or quad-speed inputs by reducing the number of instructions/sample, which can be set in the core control register.

The part can be programmed easily using SigmaStudio, a graphical tool provided by Analog Devices. No knowledge of writing DSP code is needed to program this part.

CONTROL PORT

OVERVIEW

The ADAU1702 has many different control options that can be set through an SPI or I²C interface. The ADAU1702 has both a 4-wire SPI control port, and a 2-wire I²C bus control port. At power-up, the part defaults to I²C mode, but can be put into SPI control mode by pulling pin CLATCH/WP low three times.

The control port is capable of full read/write operation for all of the memories and registers. Most signal processing parameters are controlled by writing new values to the parameter RAM using the control port. Other functions, such as mute and input/output mode control, are programmed by writing to the control registers.

All addresses may be accessed in both a single-address mode or a burst mode. A control word consists of the chip address, the register/RAM subaddress, and the data to be written. The number of bytes per word depends on the type of data that is written.

The first byte of a control word (Byte 0) contains the 7-bit chip address plus the R/W bit. The next two bytes (Bytes 1 and 2) together form the subaddress of the memory or register location within the ADAU1702. This subaddress needs to be two bytes because the memories within the ADAU1702 are directly addressable, and their sizes exceed the range of single-byte addressing. All subsequent bytes (Bytes 3, 4, etc.) contain the data, such as control port data or program or parameter data. The exact formats for specific types of writes are shown in Table 22 to Table 30.

The ADAU1702 has several mechanisms for updating signal processing parameters in real time without causing pops or clicks. In cases where large blocks of data need to be downloaded, the output of the DSP core can be halted (using Bit x of the core control register), new data loaded, and then restarted. This is typically done during the booting sequence at start-up or when loading a new program into RAM. In cases where only a few parameters need to be changed, they can be loaded without halting the program. To avoid unwanted side effects while loading parameters on the fly, the SigmaDSP provides the safeload registers. The safeload registers can be used to buffer a full set of parameters (e.g. the five coefficients of a biquad) and then transfer these parameters into the active program within one audio frame. The safeload mode uses internal logic to prevent contention between the DSP core and the control port.

SPI PORT

The SPI port uses a 4-wire interface, consisting of CLATCH, CCLK, CDATA, and COUT signals. The CLATCH signal goes low at the beginning of a transaction and high at the end of a transaction. The CCLK signal latches CDATA on a low-to-high transition. COUT data is shifted out of the ADAU1702 on the

falling edge of CCLK and should be clocked into the receiving device, such as a microcontroller, on CCLK's rising edge. The CDATA signal carries the serial input data, and the COUT signal is the serial output data. The COUT signal remains three-stated until a read operation is requested. This allows other SPI-compatible peripherals to share the same readback line. All SPI transactions follow the same basic format, shown in Table 12. A timing diagram is shown in Figure 4. All data written should be MSB-first.

Table 12. Generic Control Word Format

Byte 0	Byte 1	Byte 2	Byte 3	Byte 4, etc.
chip_adr [6:0], R/W	0000, subadr [11:8]	subadr[7:0]	data	data

Chip Address R/\bar{W}

The first byte of an SPI transaction includes the 7-bit chip address and a R/W bit. The chip address is set by the ADR_SEL pin. This allows two ADAU1702s to share a CLATCH signal, yet still operate independently. When ADR_SEL is low, the chip address is 0000000; when it is high, the address is 0000001. The LSB of this first byte determines whether the SPI transaction is a read (Logic Level 1) or a write (Logic Level 0).

Subaddress

The 12-bit Subaddress word is decoded into a location in one of the memories or registers. This subaddress is the location of the appropriate RAM location or register.

Data Bytes

The number of data bytes varies according to the register or memory being accessed. In burst write mode, an initial subaddress is given followed by a continuous sequence of data for consecutive memory/register locations. The detailed data format diagram for continuous-mode operation is given in the Control Port Read/Write Data Formats section.

A sample timing diagram for a single SPI write operation to the parameter RAM is shown in Figure 9. A sample timing diagram of a single SPI read operation is shown in Figure 10. The COUT pin goes from three-state to driven at the beginning of Byte 3. In this example, Bytes 0 to 2 contain the addresses and R/W bit, and subsequent bytes carry the data.

I²C PORT

The ADAU1702 supports a 2-wire serial (I²C compatible) micro-processor bus driving multiple peripherals. Two pins, serial data (SDA) and serial clock (SCL), carry information between the ADAU1702 and the system I²C master controller. The ADAU1702 is always a slave on the I²C bus, which means that it will never initiate a data transfer. Each slave device is recognized by a unique address. The address byte format is

shown in Table 13. The ADAU1702 has four possible slave addresses, two for writing operations and two for reading. These are unique addresses for the device and are illustrated in Table 14. The LSB of the byte sets either a read or write operation; Logic Level 1 corresponds to a read operation, and Logic Level 0 corresponds to a write operation. The sixth and seventh bits of the address are set by tying the ADDR_x pins of the ADAU1702 to logic level 0 or logic level 1.

Table 13. ADAU1702 Address Byte Format

Bit 0	Bit 1	Bit 2	Bit 3	Bit 4	Bit 5	Bit 6	Bit 7
0	1	1	0	1	ADDR1	ADDR0	R/W

Table 14. ADAU1702 I²C Addresses

ADDR1	ADDR0	Read/Write	Slave Address
0	0	0	0x68
0	0	1	0x69
0	1	0	0x6A
0	1	1	0x6B
1	0	0	0x6C
1	0	1	0x6D
1	1	0	0x6E
1	1	1	0x6F

Addressing

Initially, all devices on the I²C bus are in an idle state, which is where the devices monitor the SDA and SCL lines for a start condition and the proper address. The I²C master initiates a data transfer by establishing a Start condition, defined by a high-to-low transition on SDA while SCL remains high. This indicates that an address/data stream will follow. All devices on the bus respond to the start condition and shift the next eight bits (7-bit address + R/W bit) MSB first. The device that recognizes the transmitted address responds by pulling the data line low during the ninth clock pulse. This ninth bit is known as an acknowledge bit. All other devices withdraw from the bus at this point and return to the idle condition. The R/W bit determines the direction of the data. A logic 0 on the LSB of the first byte means the master will write information to the peripheral. A logic 1 on the LSB of the first byte means the master will read information from the peripheral. A data transfer takes place until a stop condition is encountered. A stop condition occurs when SDA transitions from low to high while SCL is held high. Figure 11 shows the timing of an I²C write.

Burst mode addressing, where the subaddresses are automatically incremented at word boundaries, can be used for writing large amounts of data to contiguous memory locations. This increment happens automatically if a stop condition is not encountered after a single-word write. The registers and memories in the ADAU1702 range in width from one to five bytes, so the autoincrement feature knows the mapping between sub-addresses and the word length of the destination register (or memory location). A data transfer is always terminated by a stop condition.

Stop and start conditions can be detected at any stage during the data transfer. If these conditions are asserted out of sequence with normal read and write operations, these cause an immediate jump to the idle condition. During a given SCL high period, the user should only issue one start condition, one stop condition, or a single stop condition followed by a single start condition. If an invalid subaddress is issued by the user, the ADAU1702 does not issue an acknowledge and returns to the idle condition. If the user exceeds the highest subaddress while in autoincrement mode, one of two actions will be taken. In read mode, the ADAU1702 outputs the highest subaddress register contents until the master device issues a no-acknowledge, indicating the end of a read. A no-acknowledge condition is where the SDA line is not pulled low on the ninth clock pulse on SCL. If the highest subaddress location is reached while in write mode, the data for the invalid byte is not loaded into any subaddress register, a no-acknowledge is issued by the ADAU1702, and the part returns to the idle condition.

I²C Read & Write Operations

Figure 13 shows the timing of a single-word write operation. Every ninth clock, the ADAU1702 issues an acknowledge by pulling SDA low.

Figure 14 shows the timing of a burst mode write sequence. This figure shows an example where the target destination registers are two bytes. The ADAU1702 knows to increment its subaddress register every two bytes because the requested subaddress corresponds to a register or memory area with a 2-byte word length.

The timing of a single word read operation is shown in Figure 15. Note that the first R/W bit is still a 0, indicating a write operation. This is because the subaddress still needs to be written in order to set up the internal address. After the ADAU1702 acknowledges the receipt of the subaddress, the master must issue a repeated start command followed by the chip address byte with the R/W set to 1 (read). This causes the ADAU1702's SDA to turn around and begin driving data back to the master. The master then responds every ninth pulse with an acknowledge pulse to the ADAU1702.

Figure 16 shows the timing of a burst-mode read sequence. This figure shows an example where the target read registers are two bytes. The ADAU1702 knows to increment its subaddress register every two bytes because the requested subaddress corresponds to a register or memory area with word lengths of two bytes. Other address ranges may have a variety of word lengths ranging from one to five bytes; the ADAU1702 always decodes the subaddress and sets the autoincrement circuit so that the address increments after the appropriate number of bytes.

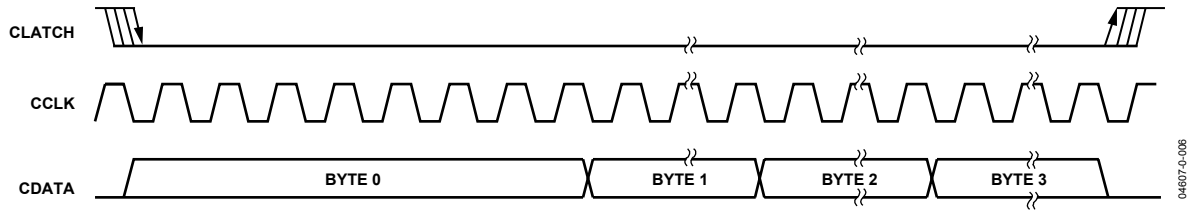

Figure 9. SPI Write format (Single-Write Mode)

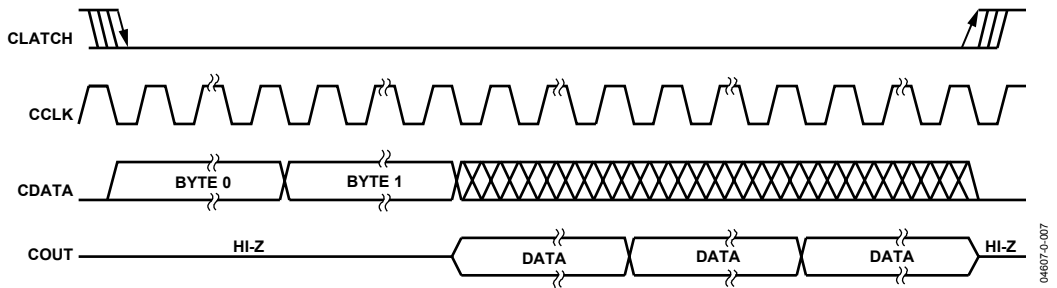

Figure 10. SPI Read Format (Single-Read Mode)

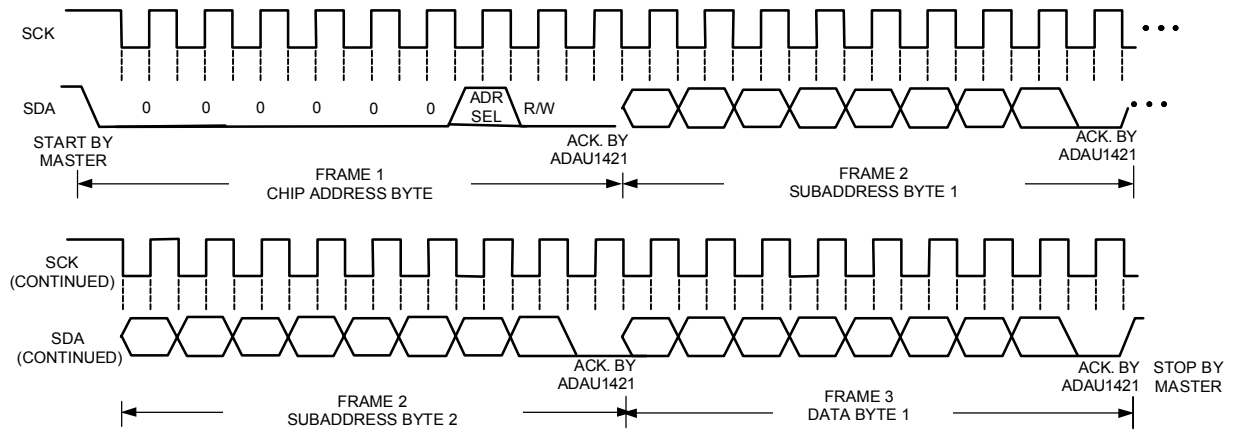

Figure 11. ADAU1702 I2C Write Format

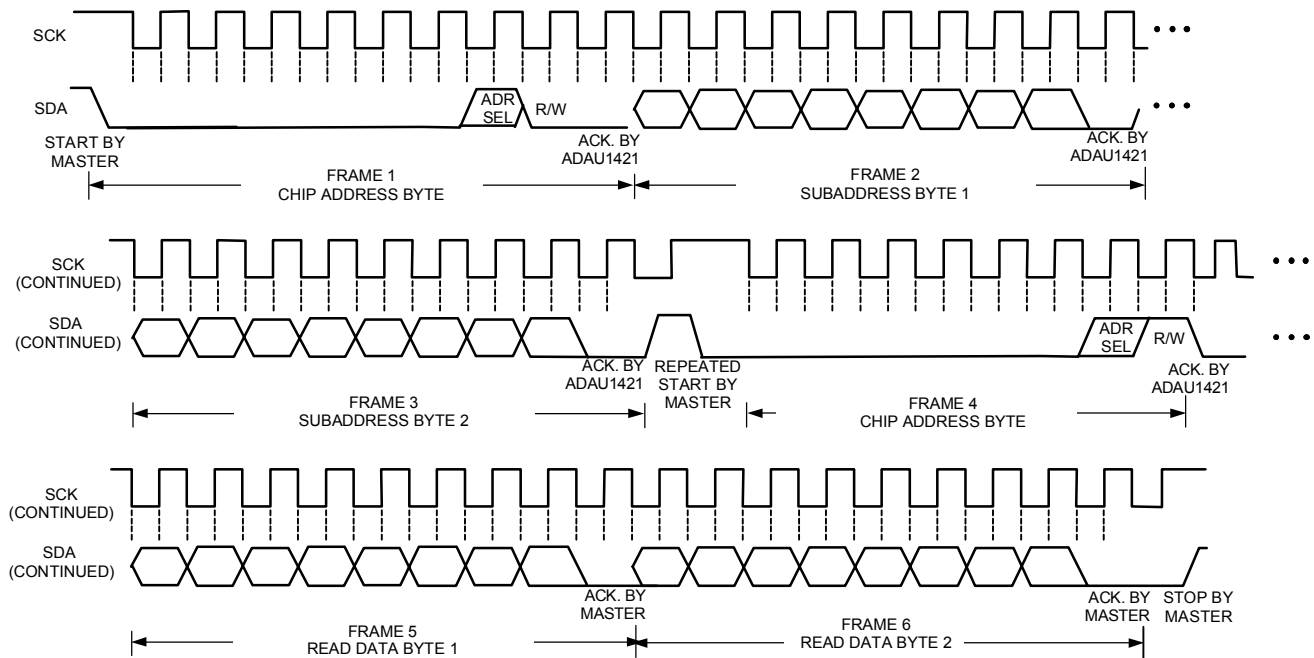

Figure 12. ADAU1702 I2C Read Format

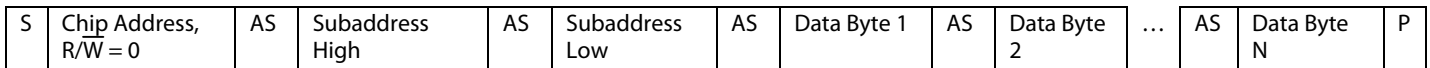

Figure 13. Single-Word I²C Write

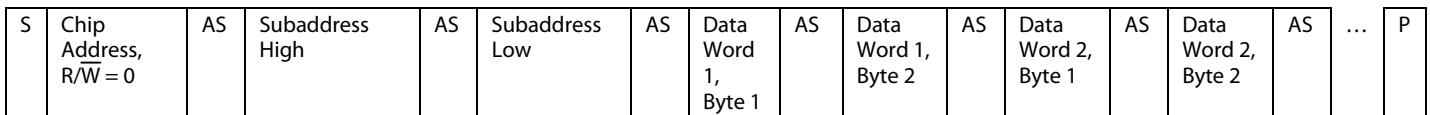

Figure 14. Burst Mode I²C Write

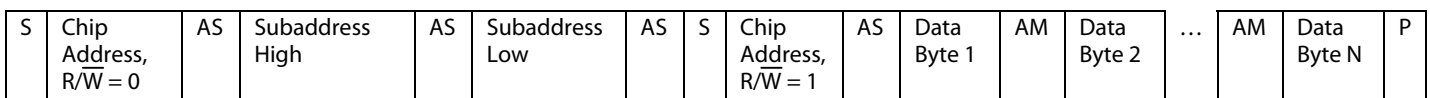

Figure 15. Single Word I²C Read

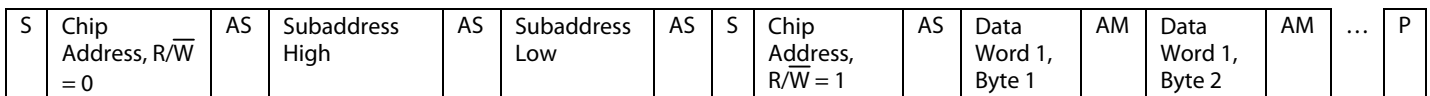

Figure 16. Burst Mode I²C Read

S - Start Bit
 P - Stop Bit
 AM - Acknowledge by Master
 AS - Acknowledge by Slave

SELF BOOT

The ADAU1702 can load a set of program and parameters that has been saved in an external EEPROM on power-up. Combined with the auxiliary ADC and the GPIO pins, this eliminates the need for a microcontroller in the system. The self-booting is accomplished by the ADAU1702 acting as a master on the I²C bus on start-up, which occurs when the

Selfboot pin is set high. The ADAU1702 cannot self-boot in SPI mode.

The maximum necessary EEPROM size is about 9 kB. This much memory will only be needed if the program RAM (512 × 5 bytes), parameter RAM (1024 × 4 bytes), and interface registers (8 × 4 bytes) are each completely full. In most

applications, an 8 kB EEPROM will be sufficient.

Pin	I ² C Mode	SPI Mode	Selfboot Mode
SCL/CCLK	SCL - input	CCLK - input	SCL - output
SDA/COU ^T	SDA – open collector output	COU ^T – output	SDA – open collector output
ADDR1/CDAT A/WB_TRIG	ADDR1 - input	CDATA - input	trigger writeback
CLATCH/WP	unused input – tie to ground or VDD	CLATCH - input	EEPROM Write Protect - open collector output Also used as input. Attach resistor to 3.3V VDD
ADDR0	ADDR0 - input	ADDR0 - input	unused input – tie to ground or VDD

A selfboot operation is triggered on the rising edge of RESETB when the SELFB^OOT and WP pines are high. The ADAU1702 reads a program, parameters, and register settings from the EEPROM. Once the ADAU1702 has finished selfbooting, further messages may be sent to the ADAU1702 on the I²C bus, although this typically won't be necessary in a selfbooting application. The I²C device address is 0x68 for a write and 0x69 for a read in this mode. The ADDR_x pins have different functions if the chip is used in this mode, so the settings on them are ignored.

The ADAU1702 will selfboot only if WP is set low. This allows the EEPROM to be programmed in-circuit. The WP signal must be pulled low (it would normally have a resistor pull-up) to enable writes to the EEPROM and this disables selfboot until WP is taken high.

EEPROM format

The EEPROM contains a sequence of messages. Each message may be one of:

- Write bytes
- Delay
- Set write back multiple times

- Set write back falling edge sensitive
- End of messages
- End of messages and wait for a writeback
- No-op message

Each message consists of a sequence of one or more bytes. The first byte determines the message type and must be one of the following shown in Table 15. Bytes are written MSB-first.

Table 15. EEPROM Message Types

Message Byte	Message Type	Following Bytes
0x00	End	none
0x01	Write	2 bytes for length followed by data bytes
0x02	Delay	2 bytes for delay
0x03	No-Op	none
0x04	Set multiple write back	none
0x05	Set to falling edge sensitive	none
0x06	End and wait for writeback	none

Most messages will be block write (0x01) types.

The body of the message following the message type should start with a 0x00 byte – this is the chip address. After this there is always a 2-byte register/memory address field, as there is with all other I²C or SPI transactions.

WriteBack

A writeback occurs when data is written to the EEPROM from the ADAU1702. This function is typically used to save volume and other parameter settings to the EEPROM just before power is removed from the system. A writeback is triggered by a rising edge on the WB_TRIG pin when the ADAU1702 is in selfboot mode, unless a Set Falling To Edge Sensitive (0x05) message was contained in the selfboot message sequence. Only one write back will take place unless a Set Multiple Write Back (0x04) message was contained in the selfboot message sequence). The ADAU1702 is only capable of writing back the contents of the interface registers to the EEPROM. These registers can be controlled by the DSP program.

Writeback operated by writing a single page of the 8kB or 16kB EEPROM. It is the second page that is written to – from EEPROM location 32 to 63. The EEPROM should contain the Message Byte (0x01), 2 length bytes, the chip address (0x00), the 2-byte subaddress for the interface registers (0x08, 0x00)

immediately before EEPROM location 32 (i.e. starting at EEPROM location 26). There must be a message to the DSP core control register to enable port writing to the interface registers prior to the interface register data in the EEPROM. This should be stored in EEPROM address 0. No-op messages (0x03) may be used in-between messages to ensure these conditions are met.

Example – EEPROM starting at EEPROM location 0

Message Byte

No-Op Message Byte

Length Bytes

Device Address Byte (0x00)

Write Back Data

0x01, 0x00, 0x05, 0x00, 0x08, 0x1c, 0x00, 0x40,
 0x03, 0x03, 0x03, 0x03, 0x03, 0x03, 0x03, 0x03,
 0x03, 0x03, 0x03, 0x03, 0x03, 0x03, 0x03, 0x03,
 0x03, 0x03, 0x01, 0x00, 0x23, 0x00, 0x08, 0x00,
 0x00, 0x00, 0x00, 0x00, 0x00, 0x00, 0x00, 0x00,
 0x00, 0x00, 0x00, 0x00, 0x00, 0x00, 0x00, 0x00,
 0x00, 0x00, 0x00, 0x00, 0x00, 0x00, 0x00, 0x00,
 0x00, 0x00, 0x00, 0x00, 0x00, 0x00, 0x00, 0x00,
 0x01, 0x01, 0x61, 0x00, 0x04, 0x00, 0x00, 0x00,
 0x00, 0x00, 0x01, 0x00, 0x00, 0x00, 0xe8, 0x01,
 0x00, 0x00, 0x00, 0x00, 0x01, 0x00, 0x08, 0x00,

RAMS AND REGISTERS

Table 16. Control Port Addresses

SPI/ I ² C Subaddress	Register/RAM Name	Read/Write Word Length
0–1023 (0x0000–0x03FF)	Parameter RAM	Write: 4 Bytes, Read: 4 Bytes
1024–1535 (0x0400–0x05FF)	Program RAM	Write: 5 Bytes, Read: 5 Bytes
1536–2047 (0x0600–0x07FF)	Reserved	
2048–2055 (0x0800–0x0807)	Interface Registers 0 - 7	Read: 4 bytes, Write: 4 bytes (set bit 6 in ccr first)
2056 (0x0808)	GPIO Pin Setting Register	Read: 2 bytes, Write: 2 bytes (set bit 7 in ccr first)
2057–2060 (0x0809–0x080C)	Aux ADC Data Registers	Read: 2 bytes (12-bits due to filtering) Write: 1 byte (no filtering, set bit 8 in ccr first)
2064–2068 (0x080D–0x0814)	Safeload Data Registers 0 – 4	Write: 5 Bytes, Read: N/A
2069–2073 (0x0815–0x0819)	Safeload Address Registers 0 - 4	Write: 2 Bytes, Read: N/A
2074–2075 (0x081A–0x081B)	Data Capture Registers 0–1	Write: 2 Bytes, Read: 3 Bytes
2076 (0x081C)	DSP Core Control Register	Write: 2 Bytes, Read: 2 Bytes
2077 (0x081D)	Reserved – do not write	Write: 1 Byte, Read: 1 Byte
2078 (0x081E)	Serial Output Control Register	Write: 2 Bytes, Read: 2 Bytes
2079 (0x081F)	Serial Input Control Register	Write: 1 Byte, Read: 1 Byte
2080–2081 (0x0820–0x0821)	Multi-Purpose Pin Configuration Registers 0 – 1	Write: 3 Bytes, Read: 3 Bytes
2082 (0x0822)	Auxiliary ADC Control Register	Write: 2 Bytes, Read: 2 Bytes
2083 (0x0823)	Reserved – do not write	Write: 2 Bytes, Read: 2 Bytes
2084 (0x0824)	Auxiliary ADC Enable Register	Write: 2 Bytes, Read: 2 Bytes

Table 17. RAM Read/Write Modes

Memory	Size	Address Range	Read	Write	Write Modes
Parameter RAM	1024 × 28	0–1023	Yes	Yes	Direct Write ¹ , Safeload Write
Program RAM	512 × 40	1024–1535	Yes	Yes	Direct Write ¹

¹ Internal registers should be cleared first to avoid clicks/pops.

CONTROL PORT ADDRESSING

Table 16 shows the addressing of the ADAU1702's RAM and register spaces. The address space encompasses a set of registers and two RAMs: one each for holding signal processing parameters and holding the program instructions. The program and parameter RAMs are initialized on power-up from on-board boot ROMs (see Power-Up Sequence section).

Table 17 shows the sizes and available writing modes of the parameter and program RAMs.

All RAMs and registers have a default value of all zeros.

PARAMETER RAM

The parameter RAM is 28 bits wide and occupies Addresses 0 to 1023. The parameter RAM is initialized to all zeros on power-up. The data format of the parameter RAM is twos complement 5.23. This means that the coefficients may range from +16.0 (minus 1 LSB) to –16.0, with 1.0 represented by the binary word 0000 1000 0000 0000 0000 0000 0000.

The parameter RAM can be written and read using one of the two following methods.

Direct Read/Write

This method allows direct access to the program and parameter RAMs. This mode of operation is normally used during a complete new load of the RAMs, using burst-mode addressing. The clear registers bit in the core control register should be set to 0 using this mode to avoid any clicks or pops in the outputs. Note that it is also possible to use this mode during live program execution, but since there is no handshaking between the core and the control port, the parameter RAM will be unavailable to the DSP core during control writes, resulting in clicks and pops in the audio stream.

Safeload Write

Up to five safeload registers can be loaded with parameter RAM address/data. The data is then transferred to the requested address when the RAM is not busy. This method can be used

for dynamic updates while live program material is playing through the ADAU1702. For example, a complete update of one biquad section can occur in one audio frame, while the RAM is not busy. This method is not available for writing to the program RAM or control registers.

The following sections discuss these two options in more detail.

RECOMMENDED PROGRAM/PARAMETER LOADING PROCEDURE

When writing large amounts of data to the program or parameter RAM in direct write mode, the processor core should be disabled to prevent unpleasant noises from appearing at the audio output.

1. Assert bits 3 and 4 (active low) of the core control register to mute the ADCs and DACs. This begins a volume ramp-down.
2. Assert bit 2 (active low) of the core control register. This zeroes the SigmaDSP’s accumulators, the data output registers, and the data input registers.
3. Fill the program RAM using burst-mode writes.
4. Fill the parameter RAM using burst-mode writes.
5. Deassert bits 2-4 of the core control register.

SAFELOAD REGISTERS

Many applications require real-time microcontroller control of signal processing parameters, such as filter coefficients, mixer gains, multi-channel virtualizing parameters, or dynamics processing curves. To prevent instability from occurring, all of the parameters of a biquad filter must be updated at the same time. Otherwise, the filter could execute for one or two audio frames with a mix of old and new coefficients. This mix could cause temporary instability, leading to transients that could take a long time to decay. To eliminate this problem, the ADAU1702 can simultaneously load a set of five 28-bit values to the desired parameter RAM address. Five registers are used because a biquad filter uses five coefficients, and it is desirable to be able to do a complete biquad update in one transaction.

The first step in performing a safeload is writing the parameter address to one of the Safeload Address Registers (2069 – 2073). The 10-bit data word that should be written is the address to which the safeload is being performed. After the Safeload Address Register is set, then the 28-bit data word can be written to the corresponding Safeload Data Register (2064 – 2068). The data formats for these writes are detailed in Table 30 and Table 31. Table 18 shows how each of the five Address Registers map to their corresponding Data Registers.

Table 18. Safeload Address & Data Register Mapping

Safeload Register	Safeload Address Register	Safeload Data Register
-------------------	---------------------------	------------------------

0	2069	2064
1	2070	2065
2	2071	2066
3	2072	2067
4	2073	2068

Once the address and data registers are loaded, the initiate safeload transfer bit in the core control register should be set to initiate the loading into RAM. Program lengths should be limited to 1,019 cycles (1,024 – 5) to ensure that the SigmaDSP core has “free cycles” to perform the safeloads. It is guaranteed that the safeload will have occurred within one LRCLK period (21 μs at f_s = 48 kHz) of the initiate safeload transfer bit being set.

The safeload logic automatically sends only those safeload registers that have been written to since the last safeload operation. For example, if only two parameters are to be sent, only two of the five safeload registers must be written. When the initiate safeload transfer bit is asserted, only those two registers are sent; the other three registers are not sent to the RAM and can still hold old or invalid data.

DATA CAPTURE REGISTERS

The ADAU1702’s data capture feature allows the data at any node in the signal processing flow to be sent to one of two control port-readable registers. This can be used to monitor and display information about internal signal levels or compressor/limiter activity.

For each of the data capture registers, a capture count and a register select must be set. The capture count is a number between 0 and 1023 that corresponds to the program step number where the capture will occur. The register select field programs one of four registers in the DSP core that will be transferred to the data capture register when the program counter equals the capture count. The register select field selections are shown in Table 19.

Table 19. Data Capture Control Registers (2074-2075)

Register Bits	Function
12:2	11-Bit Program Counter Address
1:0	Register Select

Table 20. Data Capture Output Register Select

Setting	Register
00	Multiplier X Input (Mult_X_input)
01	Multiplier Y Input (Mult_Y_input)
10	Multiplier-Accumulator Output (MAC_out)
11	Accumulator Feedback (Accum_fback)

The capture count and register select bits are set by writing to one of the eight data capture registers at register addresses

- 2074: Control Port Data Capture Setup Register 0
- 2075: Control Port Data Capture Setup Register 1

The captured data is in 5.19 twos complement data format. The four LSBs are truncated from the internal 5.23 data word.

The data that must be written to set up the data capture is a concatenation of the 11-bit program count index with the 2-bit register select field. The capture count and register select values that correspond to the desired point to be monitored in the signal processing flow can be found in a file output from the program compiler. The capture registers can be accessed by reading from locations 2074 and 2075. The format for reading and writing to the data capture registers can be seen in Table 28 and Table 29.

DSP CORE CONTROL REGISTER

The controls in this register set the operation of the ADAU1702’s DSP core.

Table 21. DSP Core Control Register (2076)

Register Bits	Function
15:14	Reserved
13:12	GPIO Debounce control 00 = 20ms 01 = 40ms 10 = 10ms 11 = 5ms
11:9	Reserved
8	Aux ADC Data registers control port write mode
7	GPIO Pin Setting register control port write mode
6	Interface registers control port write mode
5	Initiate Safeload Transfer
4	Mute ADCs, active low
3	Mute DACs, active low
2	Clear Internal Registers to All Zeros, active low
1:0	Program Length 00 = 512 (48 kHz) 01 = 256 (96 kHz) 10 = 128 (192 kHz) 00 = reserved

GPIO Debounce control (Bits 13:12)

Set debounce time of multipurpose pins set as GPIO inputs.

Aux ADC Data registers control port write mode (Bit 8)

When this bit is set, the Aux ADC Data registers (2057-2060) can be written to directly from the control port. The Aux ADC Data registers will no longer respond to settings on the multi-purpose pins.

GPIO Pin Setting register control port write mode (Bit 7)

When this bit is set, the GPIO Pin Setting register (2056) can be written to directly from the control port. The GPIO Pin Setting register will no longer respond to input settings on the multi-purpose pins.

Interface registers control port write mode (Bit 6)

When this bit is set, the Interface registers (2048-2055) can be written to directly from the control port. The Interface registers will not be set from the SigmaDSP program.

Initiate Safe Transfer to Parameter RAM (Bit 5)

Setting this bit to 1 initiates a safeload transfer to the parameter RAM. This bit is automatically cleared when the operation is completed. There are five safeload registers pairs (address/data); only those registers that have been written since the last safeload event are transferred to the parameter RAM.

Mute ADCs (Bit 4)

This bit will mute the output of the ADCs. The bit defaults to 0 and is active-low, so it must be set to 1 in order to pass audio from the ADCs.

Mute DACs (Bit 3)

This bit will mute the output of the DACs. The bit defaults to 0 and is active-low, so it must be set to 1 in order to pass audio from the DACs.

Clear Internal Registers to All Zeros (Bit 2)

This bit defaults to 0 and is active low.

Program Length (Bits 1:0)

96 kHz and 192 kHz modes

These bits set the length of the internal program. The default program length is 512 instructions for $f_s = 48$ kHz, but the program length can be shortened by factors of 2 to accommodate sample rates higher than 48 kHz. For $f_s = 96$ kHz the program length should be set to 256 (01), and the length should be set at 128 steps (10) for $f_s = 192$ kHz.

Low Power Mode

This setting can also be used to reduce the power consumption of the ADAU1702. If the program length is set to 256 steps and $f_s = 48$ kHz, instead of 96 kHz, then the digital power consumption of the part will be cut in approximately half. Correspondingly, when the program length is set to 128 steps with $f_s = 48$ kHz the digital power consumption will be about ¼ of what it is in normal operation with 512 program steps and $f_s = 48$ kHz.

INTERFACE REGISTERS

See more information in the Self boot section.

CONTROL PORT READ/WRITE DATA FORMATS

The read/write formats of the control port are designed to be byte-oriented. This allows for easy programming of common microcontroller chips. In order to fit into a byte-oriented format, 0s are appended to the data fields before the MSB in order to extend the data word to the next multiple of eight bits. For example, 28-bit words written to the parameter RAM are appended with four leading 0s in order to reach 32 bits (4 bytes); 40-bit words written to the program RAM are not

appended with any 0s because it is already a full 5 bytes. These zero-extended data fields are appended to a 3-byte field consisting of a 7-bit chip address, a read/write bit, and an 11-bit RAM/register address. The control port knows how many data bytes to expect based on the address that is received in the first three bytes.

The total number of bytes for a single-location write command can vary from four bytes (for a control register write), to eight bytes (for a program RAM write). Burst mode may be used to fill contiguous register or RAM locations. A burst mode write is

done by writing the address and data of the first RAM/register location to be written. Rather than ending the control port transaction (by issuing a stop command in I²C mode or by bringing the CLATCH signal high in SPI mode, after the data word), as would be done in a single-address write, the next data word can be written immediately without first writing its specific address. The ADAU1702 control port auto-increments the address of each write, even across the boundaries of the different RAMs and registers. Table 23 and Table 25 show examples of burst mode writes.

Table 22. Parameter RAM Read/Write Format (Single Address)

Byte 0	Byte 1	Byte 2	Byte 3	Bytes 4–6
chip_adr [6:0], W/R	00000, param_adr[10:8]	param_adr[7:0]	0000, param[27:24]	param [23:0]

Table 23. Parameter RAM Block Read/Write Format (Burst Mode)

Byte 0	Byte 1	Byte 2	Byte 3	Bytes 4–6	Byte 7	Byte 11
chip_adr [6:0], W/R	00000, param_adr[10:8]	param_adr[7:0]	0000, param[27:24]	param[23:0]	Byte 8	Byte 12
					Byte 9	Byte 13
					Byte 10	Byte 14
				<—param_adr—>	param_adr + 1	param_adr + 2

Table 24. Program RAM Read/Write Format (Single Address)

Byte 0	Byte 1	Byte 2	Bytes 3–7
chip_adr [6:0], W/R	0000, prog_adr[11:8]	prog_adr[7:0]	prog[39:0]

Table 25. Program RAM Block Read/Write Format (Burst Mode)

Byte 0	Byte 1	Byte 2	Byte 3-7	Byte 8	Byte 13
chip_adr [6:0], W/R	0000, prog_adr[11:8]	prog_adr[7:0]	prog[39:0]	Byte 9	Byte 14
				Byte 10	Byte 15
				Byte 11	Byte 16
				Byte 12	Byte 17
			<—prog_adr—>	prog_adr + 1	prog_adr + 2

Table 26. Control Register Read/Write Format (Core, Serial Out 0, Serial Out 1)

Byte 0	Byte1	Byte 2	Byte 3	Byte 4
chip_adr [6:0], W/R	0000, reg_adr[11:8]	reg_adr[7:0]	data[15:8]	data[7:0]

Table 27. Control Register Read/Write Format (RAM Configuration, Serial Input)

Byte 0	Byte1	Byte 2	Byte 3
chip_adr [6:0], W/R	0000, reg_adr[11:8]	reg_adr[7:0]	data[7:0]

Table 28. Data Capture Register Write Format

Byte 0	Byte 1	Byte 2	Byte 3	Byte 4
chip_adr [6:0], W/R	0000, data_capture_adr[11:8]	data_capture_adr[7:0]	000, progCount[10:6] ¹	progCount[5:0] ¹ , regSel[1:0] ²

¹ progCount[10:0] = value of program counter where trap occurs (the table of values is generated by the program compiler).

² RegSel[1:0] selects one of four registers (see Data Capture Registers section).

Table 29. Data Capture (Control Port Readback) Register Read Format

Byte 0	Byte 1	Byte 2	Bytes 3-5
chip_adr [6:0], W/R	0000, data_capture_adr[11:8]	data_capture_adr[7:0]	data[23:0]

Table 30. Safeload Address Register Write Format

Byte 0	Byte 1	Byte 2	Byte 3	Byte 4
chip_adr [6:0], W/R	0000, safeload_adr[11:8]	safeload_adr[7:0]	000000, param_adr[9:8]	param_adr[7:0]

Table 31. Safeload Data Register Write Format

Byte 0	Byte 1	Byte 2	Byte 3	Byte 4	Bytes 5-7
chip_adr [6:0], W/R	0000, safeload_adr[11:8]	safeload_adr[7:0]	00000000	0000, data[27:24]	data[23:0]

MULTIPURPOSE PINS

Table 32. Multi-Purpose Pin Configuration Registers

Register	Bits[23:20]	Bits[19:16]	Bits[15:12]	Bits[11:8]	Bits[7:4]	Bits[3:0]
MP_CFG0 (2080)	MP5[3:0]	MP4[3:0]	MP3[3:0]	MP2[3:0]	MP1[3:0]	MP0[3:0]
MP_CFG1 (2081)	MP11[3:0]	MP10[3:0]	MP9[3:0]	MP8[3:0]	MP7[3:0]	MP6[3:0]

The ADAU1702 has 12 multipurpose pins which can be individually programmed to be used as serial data inputs, serial data outputs, digital control inputs and outputs to and from the SigmaDSP core, or as inputs to the four-channel auxiliary ADC.

GPIO PIN SETTING REGISTER

The GPIO pin settings can be directly written to or read from this register after setting bit 7 of the Core Control Register.

Table 33. GPIO Pin Setting Register (2056)

Register Bits	Function
15:12	Unused
11	MP11 setting
10	MP10 setting
9	MP9 setting
8	MP8 setting
7	MP7 setting
6	MP6 setting
5	MP5 setting
4	MP4 setting
3	MP3 setting
2	MP2 setting
1	MP1 setting
0	MP0 setting

MULTI-PURPOSE PIN CONFIGURATION REGISTERS

Each multi-purpose pin can be set to its different functions from this register. The MSB of each MP pin's 4-bit configuration inverts the input to or output from the pin.

Table 34. Multi-Purpose Pin Configuration Register Bit Functions

MPx[3:0]	Pin Function
1111	Aux ADC input (see Table 35)
1110	Reserved
1101	Reserved
1100	Serial Data Port – inverted (see Table 38)
1011	Open Collector Output - inverted
1010	GPIO Output – inverted
1001	GPIO Input, no debounce – inverted
1000	GPIO Input, debounced – inverted
0111	N/A
0110	Reserved
0101	Reserved
0100	Serial Data Port (see Table 38)

0011	Open Collector Output
0010	GPIO Output
0001	GPIO Input, no debounce
0000	GPIO Input, debounced

AUXILIARY ADC

The ADAU1702 has a four-channel auxiliary 8-bit ADC that can be used to connect a potentiometer to control volume, tone, or other parameter settings in the DSP program. Each of the four channels is sampled at the sampling frequency (f_s), which defaults to 48 kHz with a 12.288 MHz crystal connected to the ADAU1702 oscillator. Full-scale input on this ADC is 3.3V, so the step size is approximately 13mV (3.3V/256 steps).

The auxiliary ADC is turned on by writing a 1 to bit 15 of the Aux ADC enable register (Table 37).

Noise on the ADC input could cause the digital output to be constantly changing by a few LSBs. In cases where the aux ADC is used as a volume control, this would cause small gain fluctuations. To avoid this, a low-pass filter or hysteresis can be added to the aux ADC signal path. These functions can be enabled through the Auxiliary ADC Control Register (2082), shown in Table 36. The filter is enabled by default when the aux ADC is enabled.

Table 35. Multi-Purpose Pin Aux ADC Mapping

Multipurpose Pin	Function
MP0	N/A
MP1	N/A
MP2	ADC1
MP3	ADC2
MP4	N/A
MP5	N/A
MP6	N/A
MP7	N/A
MP8	ADC3
MP9	ADC0
MP10	N/A
MP11	N/A

Table 36. Auxiliary ADC Control Register (2082)

Register Bits	Function
15:10	Reserved
9:8	Aux ADC Filtering 00 = 4-bit hysteresis (12 bit level) 01 = 5-bit hysteresis (12 bit level)

7:0	01 = Hysteresis bypassed 11 = Low-pass filter bypassed Reserved
-----	---

Table 37. Aux ADC Enable Register (2084)

Register Bits	Function
15	Enable Auxiliary ADC
14:0	Reserved

GENERAL PURPOSE INPUT/OUTPUTS

The general purpose input/output (GPIO) pins can be used as either inputs or outputs. These pins are readable and settable either through the control interface or directly by the SigmaDSP core. When set as inputs, they can be used with push-button switches or rotary encoders to control DSP program settings. Digital outputs may be used to drive LEDs (with an external buffer) to indicate the status of internal signals. Examples of this use include indicating signal overload, signal present, and button press confirmation.

SERIAL DATA INPUT/OUTPUT PORTS

The ADAU1702’s flexible serial data input and output ports can be set to accept or transmit data in 2-channel formats or in an 8-channel TDM stream. Data is processed in twos complement, MSB-first format. The left channel data field always precedes the right channel data field in the 2-channel streams. In the TDM modes, slots 0 to 3 fall in the first half of the audio frame, and slots 4 to 7 are in the second half of the frame. TDM mode allows fewer multipurpose pins to be used so that they can be used for other functions. The serial modes are set in the serial output and serial input control registers.

The input control register allows control of clock polarity and data input modes. The valid data formats are I²S, left-justified, right-justified (24-, 20-, 18-, or 16-bit), and 8-channel TDM. In all modes except for the right-justified modes, the serial port will accept an arbitrary number of bits up to a limit of 24. Extra bits will not cause an error, but they will be truncated internally. Proper operation of the right-justified modes requires that there be exactly 64 BCLKs per audio frame. The TDM data is input on SDATA_IN0. The LRCLK in TDM mode can be input to the

Table 40. Data Format Configurations

Format	LRCLK Polarity	LRCLK Type	BCLK Polarity	MSB Position
I ² S (Figure 17)	Frame begins on falling edge	Clock	Data changes on falling edge	Delayed from LRCLK edge by one BCLK
Left-Justified (Figure 18)	Frame begins on rising edge	Clock	Data changes on falling edge	Aligned with LRCLK edge
Right-Justified (Figure 19)	Frame begins on rising edge	Clock	Data changes on falling edge	Delayed from LRCLK edge by 8, 12, or 16 BCLKs
TDM with Clock (Figure 20)	Frame begins on falling edge	Clock	Data changes on falling edge	Delayed from start of word clock by one BCLK
TDM with Pulse (Figure 21)	Frame begins on rising edge	Pulse	Data changes on falling edge	Delayed from start of word clock by one BCLK

ADAU1702 as either a 50/50 duty cycle clock or as a bit-wide pulse. In TDM mode, the ADAU1702 can be a master for 48 kHz and 96 kHz data, but not for 192 kHz data. Table 39 displays the modes in which the serial output port will function.

The output control registers give the user control of clock polarities, clock frequencies, clock types, and data format. In all modes except for the right-justified modes (MSB delayed by 8, 12, or 16), the serial port accepts an arbitrary number of bits up to a limit of 24. Extra bits will not cause an error, but will be truncated internally. Proper operation of the right-justified modes requires the LSB to align with the edge of the LRCLK. The default settings of all serial port control registers correspond to 2-channel I²S mode. All register settings apply to both master and slave modes unless otherwise noted. Table 40 shows the proper configurations for standard audio data formats.

Table 38. Multi-Purpose Pin Serial Data Port Functions

Multipurpose Pin	Function
MP0	SDATA_IN0/TDM_IN
MP1	SDATA_IN1
MP2	SDATA_IN2
MP3	SDATA_IN3
MP4	LRCLK_IN
MP5	BCLK_IN
MP6	SDATA_OUT0/TDM_OUT
MP7	SDATA_OUT1
MP8	SDATA_OUT2
MP9	SDATA_OUT3
MP10	LRCLK_OUT
MP11	BCLK_OUT

Table 39 Serial Output Port Master/Slave Mode Capabilities

f _s	2-Channel Modes (I ² S, Left-Justified, Right-Justified)	8-Channel TDM
48 kHz	Master and slave	Master and slave
96 kHz	Master and slave	Master and slave
192 kHz	Master and slave	Slave only

Table 41. Serial Output Control Register (2078)

Register Bits	Function
15:14	Unused
13	LRCLK Polarity 0 = Frame Begins on Falling Edge 1 = Frame Begins on Rising Edge
12	BCLK Polarity 0 = Data Changes on Falling Edge 1 = Data Changes on Rising Edge
11	Master/Slave 0 = Slave 1 = Master
10:9	BCLK Frequency (Master Mode only) 00 = core_clock/16 01 = core_clock/8 10 = core_clock/4 11 = core_clock/2
8:7	Frame Sync Frequency (Master Mode only) 00 = core_clock/1024 01 = core_clock/512 10 = core_clock/256
6	Frame Sync Type 0 = LRCLK 1 = Pulse
5	Serial Output/TDM Mode Control 0 = 8 Serial Data Outputs 1 = Enable TDM on SDATA_OUTx
4:2	MSB Position 000 = Delay by 1 001 = Delay by 0 010 = Delay by 8 011 = Delay by 12 100 = Delay by 16 101 Reserved 111 Reserved
1:0	Output Word Length 00 = 24 Bits 01 = 20 Bits 10 = 16 Bits 11 = Reserved

SERIAL OUTPUT CONTROL REGISTERS

LRCLK Polarity (Bit 13)

When set to 0, the left channel data is clocked when LRCLK is low, and the right data clocked when LRCLK is high. When set to 1, this is reversed.

BCLK Polarity (Bit 12)

This bit controls on which edge of the bit clock the output data is clocked. Data changes on the falling edge of BCLK_OUTx when this bit is set to 0, and on the rising edge when this bit is set at 1.

Master/Slave (Bit 11)

This bit sets whether the output port is a clock master or slave. The default setting is slave; on power-up, Pins BCLK_OUTx and LRCLK_OUTx are set as inputs until this bit is set to 1, at which time they become clock outputs.

BCLK Frequency (Bits 10:9)

When the output port is being used as a clock master, these bits set the frequency of the output bit clock, which is divided down from the internal core clock.

Frame Sync Frequency (Bits 8:7)

When the output port is used as a clock master, these bits set the frequency of the output word clock on the LRCLK_OUTx pins, which is divided down from the internal core clock.

Frame Sync Type (Bit 6)

This bit sets the type of signal on the LRCLK_OUTx pins. When set to 0, the signal is a word clock with a 50% duty cycle; when set to 1, the signal is a pulse with a duration of one bit clock at the beginning of the data frame.

Serial Output/TDM Mode Control (Bit 5)

Setting this bit to 1 changes the output port from multiple serial outputs to a single TDM output stream on the appropriate SDATA_OUTx pin. This bit must be set in both serial output control registers to enable 16-channel TDM on SDATA_OUT0.

MSB Position (Bits 4:2)

These three bits set the position of the MSB of data with respect to the LRCLK edge. The data output of the ADAU1702 is always MSB first.

Output Word Length (Bits 1:0)

These bits set the word length of the output data-word. All bits following the LSB are set to 0.

Table 42. Serial Input Control Register (2079)

Register Bits	Function
7:5	Unused
4	LRCLK polarity 0 = Frame begins on falling edge 1 = Frame begins on rising edge
3	BCLK polarity 0 = Data changes on falling edge 1 = Data changes on rising edge
2:0	Serial Input Mode 000 = I ² S 001 = Left-justified 010 = TDM 011 = Right-justified, 24-bit 100 = Right-justified, 20-bit 101 = Right-justified, 18-bit 110 = Right-justified, 16-bit

SERIAL INPUT CONTROL REGISTER

LRCLK Polarity (Bit 4)

When set to 0, the left channel data on the SDATA_INx pins is clocked when LRCLK_IN is low; and the right input data clocked when LRCLK_IN is high. When set to 1, this is reversed. In TDM mode, when this bit is set to 0, data is clocked in starting with the next appropriate BCLK edge (set in Bit 3 of this register) following a falling edge on the LRCLK_IN pin. When set to 1 and running in TDM mode, the input data is valid on the BCLK edge following a rising edge on the word clock (LRCLK_IN). The serial input port can also operate with a pulse input signal, rather than a clock. In this case, the first edge of the pulse is used by the ADAU1702 to start the data frame. When this polarity bit is set to 0, a low pulse should be

used, and a high pulse should be used when the bit is set to 1.

BCLK Polarity (Bit 3)

This bit controls on which edge of the bit clock the input data changes, and on which edge it is clocked. Data changes on the falling edge of BCLK_IN when this bit is set to 0, and on the rising edge when this bit is set at 1.

Serial Input Mode (Bits 2:0)

These two bits control the data format that the input port expects to receive. Bits 3 and 4 of this control register will override the settings in Bits 2:0, so all four bits must be changed together for proper operation in some modes. The clock diagrams for these modes are shown in Figure 17, Figure 18, and Figure 19. Note that for left-justified and right-justified modes the LRCLK polarity is high, then low, which is opposite from the default setting of Bit 4.

When these bits are set to accept a TDM input, the ADAU1702's data starts after the edge defined by Bit 4. Figure 20 shows a TDM stream with a high-to-low triggered LRCLK and data changing on the falling edge of the BCLK. The ADAU1702 expects the MSB of each data slot delayed by one BCLK from the beginning of the slot, just like in the stereo I²S format. In TDM mode, Channels 0 to 3 will be in the first half of the frame, and Channels 4 to 7 will be in the second half. Figure 21 shows an example of a TDM stream running with a pulse word clock, which would be used to interface to ADI codecs in their auxiliary mode. To work in this mode on either the input or output serial ports, the ADAU1702 should be set to frame beginning on the rising edge of LRCLK, data changing on the falling edge of BCLK, and MSB position delayed from the start of the word clock by one BCLK.

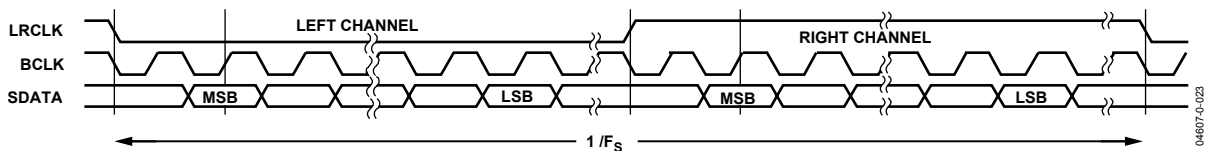

Figure 17. I²S Mode—16 to 24 Bits per Channel

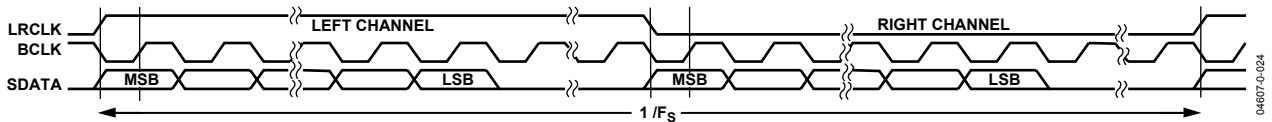

Figure 18. Left-Justified Mode—16 to 24 Bits per Channel

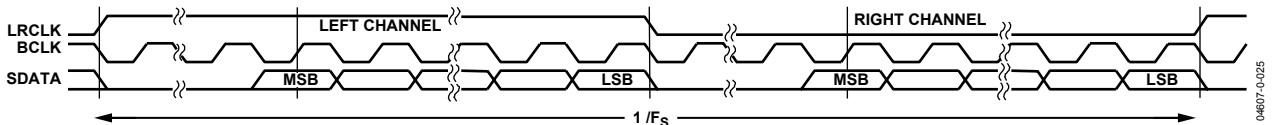

Figure 19. Right-Justified Mode—16 to 24 Bits per Channel

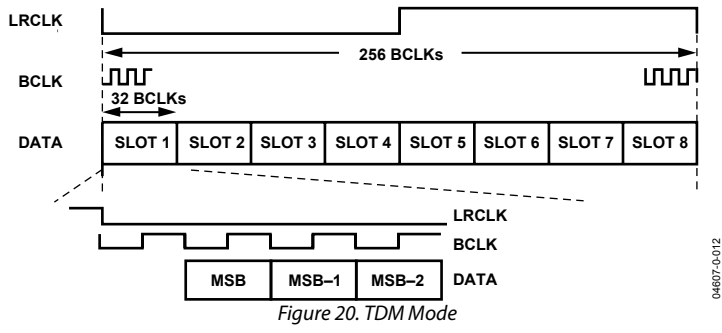

Figure 20. TDM Mode

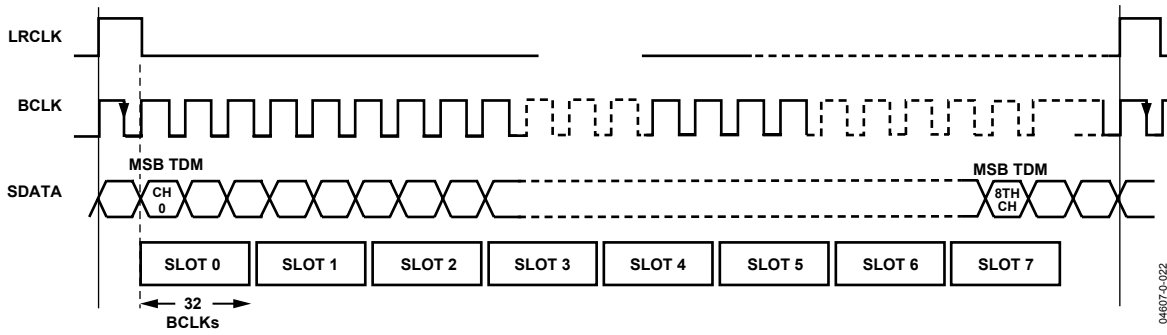

Figure 21. TDM Mode with Pulse Word Clock

TWO-CHANNEL AUDIO ADC

The ADAU1702 has a two-channel ADC. The SNR of the ADCs is 102 dB and the THD+N is -90 dB.

The stereo audio ADCs are current-input, so a voltage-to-current resistor is required on the inputs. This means that the voltage level of the input signals to the system can be set to any level; only the input resistors need to scale to provide the proper full-scale current input. A full-scale current input is 100

μArms , so a 2 Vrms signal with a 20 k Ω series resistor will give an input using the full range of the ADC.

FOUR-CHANNEL DAC

The ADAU1702's main output is a four-channel DAC. The SNR of the DAC is 103 dB and the THD+N is -90 dB. A full-scale output on the DACs is 1V_{rms}.

INITIALIZATION

POWER-UP SEQUENCE

The ADAU1702 has a built-in power-up sequence that initializes the contents of all internal RAMs. During this time, the contents of the internal program boot ROM are copied to the internal program RAM memory, and the parameter RAM (all zeros) is filled with values from its associated boot ROM. The default boot ROM program simply copies inputs to outputs with no processing. By default, serial digital inputs 0-1 are output on DACs 0-1 and serial digital outputs 0-1. ADCs 0-1 are output on DACs 2-3 (Figure 22). The data memories are also cleared during this time.

The PLL start-up time lasts for 2^{18} cycles of the clock on the MCLKI pin. This is measured from the rising edge of RESETB. Following the PLL start-up the ADAU1702's boot cycle takes 2048 cycles of the internal master clock (xxx MHz). The user should avoid writing to or reading from the ADAU1702 during this start-up time. For a 12.288 MHz input MCLK, the full boot sequence (PLL start-up plus boot cycle) will last approximately 22 ms. Coming out of reset, the clock mode is immediately set by the PLL_CTRL0 and PLL_CTRL1 pins. Reset is synched to the falling edge of the internal MCLK.

Figure 22. Default Program Signal Flow

SETTING MASTER CLOCK/PLL MODE

The ADAU1702's MCLK input feeds a PLL, which generates the clock to run the DSP core. In normal operation, the input to MCLK must be one of the following: $64 \times f_s$, $256 \times f_s$, $384 \times f_s$, or $512 \times f_s$, where f_s is the input sampling rate. The mode is set on PLL_CTRL0, PLL_CTRL1, and PLL_CTRL2, according to Table 43. If the ADAU1702 is set to receive double-rate signals (by reducing the number of program steps/sample by a factor of 2 using the core control register), then the master clock frequencies must be either $32 \times f_s$, $128 \times f_s$, $192 \times f_s$, or $256 \times f_s$. If the ADAU1702 is set to receive quad-rate signals (by reducing the number of program steps/sample by a factor of 4 using the

core control register), then the master clock frequencies must be one of $16 \times f_s$, $64 \times f_s$, $96 \times f_s$, or $128 \times f_s$. On power-up, a clock signal must be present on MCLK so that the ADAU1702 can complete its initialization routine. The PLL can also run in bypass mode, where the clock present on MCLK is fed directly to the DSP core, although this setting is not recommended for normal operation.

Table 43. PLL Modes

MCLKI Input	PLL_MODE0	PLL_MODE1
$64 \times f_s$	0	0
$256 \times f_s$	0	1
$384 \times f_s$	1	0
$512 \times f_s$	1	1

The clock mode should not be changed without also resetting the ADAU1702. If the mode is changed on the fly, a click or pop may result on the outputs. The state of the PLL_CTRLx pins should be changed while RESETB is held low.

VOLTAGE REGULATOR

The ADAU1702 include an on-board voltage regulator that allows the chip to be used in systems where a 1.8 V supply is not available, but 3.3 V is. The only external components needed for this are a PNP transistor, one resistor, and bypass capacitors. Only one pin, VDRIVE, is necessary to support the regulator.

The recommended design for the voltage regulator is shown in Figure 23. The 10 μ F and 100 nF capacitors shown in this schematic are recommended for bypassing, but are not necessary for operation. Here, VDD is the main system voltage (3.3 V). 1.8 V is generated at the transistor's collector, which is connected to the DVDD pins. VDRIVE is connected to the base of the PNP transistor. If the regulator is not used in the design VDRIVE can be tied to ground.

Figure 23. Voltage Regulator Design

LAYOUT RECOMMENDATIONS

PARTS PLACEMENT

These parts should be placed close to the ADAU1702.

The ADC input voltage-to-current resistors should be placed as close to the input pins (2 & 4) as possible.

GROUNDING

A single ground plane should be used in the application layout.

OUTLINE DIMENSIONS

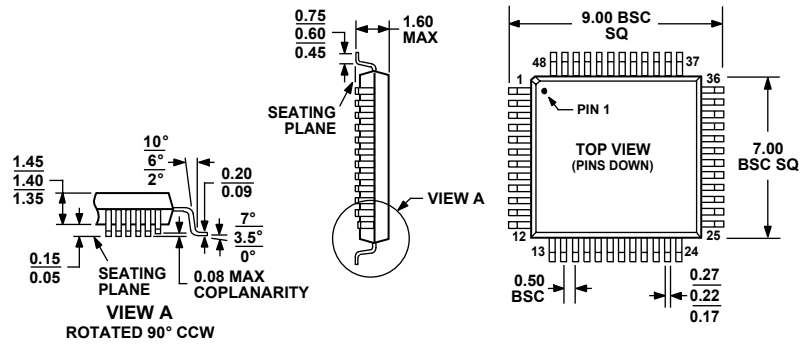

COMPLIANT TO JEDEC STANDARDS MS-026BBC

Figure 24. 48-Lead Low-Profile Quad Flat Package [LQFP]
Dimensions Shown in Millimeters

ORDERING GUIDE

Model	Temperature Range	Package Description	Package Option
ADAU1702KST	0°C to 70°C	48-Lead LQFP	ST-48
ADAU1702KST-RL	0°C to 70°C	48-Lead LQFP Evaluation Board	ST-48 in 13" Reel

NOTES

NOTES