

T8535B/T8536B Quad Programmable Codec

Features

- 5 V operation
- Per-channel programmable gains, equalization, termination impedance, and hybrid balance
- Programmable μ -law, linear, or A-law modes:
 - Up to 256 time slots per frame
 - Supports PCM data rates of 512 kbits/s to 16.384 Mbits/s
 - Double-clock mode timing compatible with ISDN standard interfaces
- Fully programmable time-slot assignment with bit offset
- Analog and digital loopback test modes
- Serial microprocessor interface:
 - Normal and byte-by-byte control modes
 - Fast scan mode
- Six bidirectional control leads per channel, for SLIC and line card function control
- Differential analog output:
 - Mates directly to SLICs, eliminating external components
- Sigma-delta converters with dither noise reduction
- Quad design to minimize package count on dense line card applications
- Meets or exceeds ITU-T G.711—G.712 and relevant *Telcordia Technologies*TM requirements

Description

The device consists of four independent channels of codec and digital signal processing functions on one chip. In addition to the classic A-to-D and D-to-A conversion, each channel provides termination impedance synthesis and a hybrid balance network.

The device is controlled by a serial microprocessor interface, and a series of bidirectional I/O leads are provided so that this control mechanism can be utilized to operate the battery feed device, ringing voltage switches, etc. Common data and clock paths can be shared over any number of devices. All the filter coefficients, signal processing, SLIC, and test features are accessible through this interface. This serial interface can be operated at speeds up to 4.096 Mbits/s.

The choice of a PCM bus is also programmable, with any channel capable of being assigned to any time slot. The PCM bus can be operated at speeds up to 16.384 Mbits/s, allowing for a maximum of 256 time slots. Separate transmit and receive interfaces are available for 4-wire bus designs, or they can be strapped together for a 2-wire PCM bus.

The device is available in four packages:

The T8536B 64-pin TQFP features five data latches per channel and the 100-pin TQFP features six-data latches per channel. Both devices have two PCM ports and are pin-compatible with the T8538B 3.3 V Quad Programmable Codec.

The T8536B 68-pin PLCC features six data latches per channel and has one PCM port. This device is pin-compatible with the T8534 Quad Programmable Echo Canceller Codec.

The T8535B 44-pin PLCC has no data latches and has one PCM port. This device is pin-compatible with the T8533 Quad Programmable Echo Canceller Codec.

Table of Contents

Contents	Page
Features	1
Description.....	1
General Description	4
Pin Information	5
Functional Description	13
Clocking Considerations	13
The Control Interface	13
Modes	13
Protocol	14
Write Command	16
Read Command	18
Fast Scan Mode	20
Write All Channels.....	23
Reset Functionality	23
Memory Control Mapping	24
Standby Mode.....	24
Test Capabilities	24
SLIC Control Capabilities.....	24
Suggested Initialization Procedures.....	25
Signal Processing	25
Absolute Maximum Ratings.....	26
Operating Ranges	26
Handling Precautions	26
Electrical Characteristics	27
dc Characteristics	27
Analog Interface.....	28
Gain and Dynamic Range.....	29
Noise Characteristics	31
Distortion and Group Delay.....	32
Crosstalk	33
Timing Characteristics.....	34
Control Interface Timing.....	34
Serial Control Port Timing	34
Normal Mode.....	35
Byte-by-Byte Mode.....	35
PCM Interface Timing	36
Single-Clocking Mode	36
Double-Clocking Mode.....	38
Software Interface	40
Applications	44
Outline Diagrams.....	45
100-Pin TQFP	45
68-Pin PLCC	46
64-Pin TQFP	47
44-Pin PLCC	48
Ordering Information.....	49

Table of Contents (continued)

Figures	Page
Figure 1. Functional Block Diagram, Each Section.....	4
Figure 2. 44-Pin PLCC Pin Diagram	5
Figure 3. 68-Pin PLCC Pin Diagram	7
Figure 4. 100-Pin TQFP Pin Diagram	9
Figure 5. 64-Pin TQFP Pin Diagram	11
Figure 6. Command Frame Format, Master to Slave, Read or Write Commands	15
Figure 7. Command Frame Format, Slave to Master, Read Commands.....	15
Figure 8. Write Operation, Normal Mode (Continuous DCLK)	16
Figure 9. Write Operation, Normal Mode (Gapped DCLK)	16
Figure 10. Write Operation, Byte-by-Byte Mode (Gapped DCLK).....	17
Figure 11. Write Operation, Byte-by-Byte Mode (Continuous DCLK)	17
Figure 12. Read Operation, Normal Mode (Continuous DCLK)	18
Figure 13. Read Operation, Normal Mode (Gapped DCLK)	19
Figure 14. Read Operation, Byte-by-Byte Mode (Gapped DCLK)	19
Figure 15. Read Operation, Byte-by-Byte Mode (Continuous DCLK)	20
Figure 16. Fast Scan, Normal Mode (Continuous DCLK)	21
Figure 17. Fast Scan, Normal Mode (Gapped DCLK)	21
Figure 18. Fast Scan, Byte-by-Byte Mode (Gapped DCLK)	22
Figure 19. Fast Scan, Byte-by-Byte Mode (Continuous DCLK)	22
Figure 20. Hardware Reset Procedure	23
Figure 21. Internal Signal Processing	25
Figure 22. Serial Interface Timing, Normal Mode (One Byte Transfer and Continuous DCLK Shown)	35
Figure 23. Serial Interface Timing, Byte-by-Byte Mode (One Byte Transfer and Gapped DCLK Shown).....	35
Figure 24. Single-Clocking Mode (TXBITOFF = 0, RXBITOFF = 0, PCMCTRL2 = 0x00)	37
Figure 25. Single-Clocking Mode (TXBITOFF = 1, RXBITOFF = 2, PCMCTRL2 = 0x01)	37
Figure 26. Double-Clocking Mode (RXBITOFF = 0x20, PCMCTRL2 = 0x00)	39
Figure 27. POTS Interface	44

Tables	Page
Table 1. Pin Assignments, 44-Pin PLCC, Per-Channel Functions.....	5
Table 2. Pin Assignments, 44-Pin PLCC, Common Functions	6
Table 3. Pin Assignments, 68-Pin PLCC, Per-Channel Functions.....	7
Table 4. Pin Assignments, 68-Pin PLCC, Common Functions	8
Table 5. Pin Assignments, 100-Pin TQFP, Per-Channel Functions.....	9
Table 6. Pin Assignments, 100-Pin TQFP, Common Functions	10
Table 7. Pin Assignments, 64-Pin TQFP, Per-Channel Functions.....	11
Table 8. Pin Assignments, 64-Pin TQFP, Common Functions	12
Table 9. Bit Assignments for Fast Scan Mode	20
Table 10. dc Characteristics.....	27
Table 11. Analog Interface	28
Table 12. Power Dissipation	28
Table 13. Gain and Dynamic Range	29
Table 14. Per-Channel Noise Characteristics	31
Table 15. Distortion and Group Delay	32
Table 16. Crosstalk	33
Table 17. Serial Control Port Timing	34
Table 18. PCM Interface Timing: Single-Clocking Mode	36
Table 19. PCM Interface Timing: Double-Clocking Mode	38
Table 20. Memory Mapping	40
Table 21. Control Bit Definition	41

General Description

Refer to Figure 1 for the following discussion.

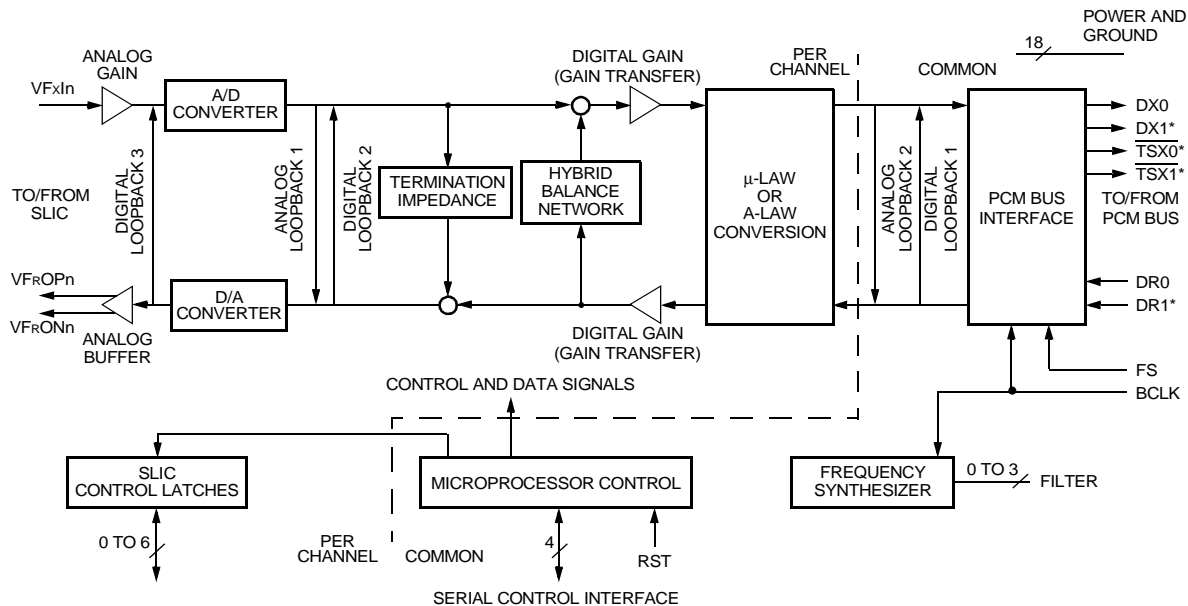

5-8125aF

* Second PCM port not available in all package types.

Figure 1. Functional Block Diagram, Each Section

This device performs virtually all the signal processing functions associated with a central office line termination. Functionality includes line termination impedance synthesis, fixed hybrid balance impedance synthesis, and level conversion both in the analog sense to accommodate various subscriber line interface circuits (SLICs) and in the digital sense for adjustment of the levels on the PCM bus. In general, the termination impedance synthesis generates the equivalent of a circuit with the parallel combination of a capacitor and a resistor in series with a resistor, or the parallel combination of a resistor and the series combination of a resistor and capacitor. These general forms of impedance characteristics will satisfy most of the requirements specified throughout the world. Programmable selection of either μ -law or A-law encoding further aids worldwide deployment. All coefficients used in the filtering algorithms can be computed off-line in advance and downloaded to the device at the time of powerup. All signal processing is contained within the device, and there are only three interfaces of consequence to the system designer: the SLIC interface, the PCM interface, and the control interface.

The SLIC interface is designed to be flexible and convenient to use with a variety of SLIC circuits. With an appropriate choice of SLIC, no external components are required in the interface, with the exception of a dc blocking capacitor in the transmit direction. In some cases, dc blocking capacitors in the receive direction may be necessary as well, since the device operates from a single low-voltage supply.

The PCM bus interface is flexible in that it allows, independently, the transmit and receive data for any channel to be placed in any time slot. The bus can be operated at a maximum 16.384 Mbits/s rate to accommodate a maximum 256 time slots. Separate pins are provided for each direction of transmission to allow 4-wire bus operation. The frame strobe signal is an 8 kHz signal that defines the beginning of the frame structure for all four channels. The interface will count 8 bits per time slot and insert or read the data for each channel as programmed. Lower speeds of the PCM bus are allowed. The PCM clock must be synchronous with the frame strobe signal.

The microprocessor control interface is a serial interface that uses the classical chip select type of operation. The interface controls the device by writing or reading various internal addresses. The command set consists of simple read and write operations, with the address determining the effect. All the memory locations, including the per-chip functions, are organized by channel.

There are several test modes included to facilitate confirmation of correct operation. In the signal path, two analog and three digital loopback tests are available, while in the microprocessor interface, there is a write/read test mode that tests the operation of the memory. Use of external test access switches allows a complete test of the signal path through the line card so that correct operation of various operational modes can be verified.

Pin Information

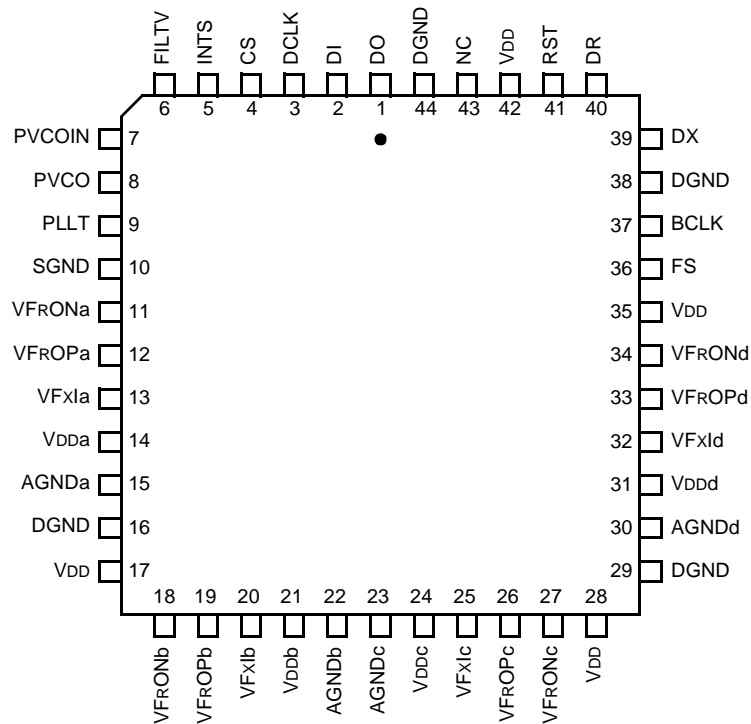

5-7187.b(F)

Figure 2. 44-Pin PLCC Pin Diagram

Table 1. Pin Assignments, 44-Pin PLCC, Per-Channel Functions

Ckt				Name	Type	Name/Description
a	b	c	d			
15	22	23	30	AGND	GND	Analog Ground. A common AGND, DGND, SGND plane is highly recommended.
14	21	24	31	V _{DD}	PWR	Analog Power Supply.
13	20	25	32	VFXl	I	Voice Frequency Transmit Input. This node requires a 10 MΩ or 20 MΩ resistance to AGND. The value is dependent upon the gain of the XAG amplifier (register 146). 20 MΩ can be used for any gain setting, 10 MΩ can only be used for XAG gain settings of 0 dB and +6.02 dB.
12	19	26	33	VFR _{OP}	O	Voice Frequency Receive Output, Positive Polarity. This pin can drive 2000 Ω (or greater) loads.
11	18	27	34	VFR _{ON}	O	Voice Frequency Receive Output, Negative Polarity. This pin can drive 2000 Ω (or greater) loads.

Pin Information (continued)**Table 2. Pin Assignments, 44-Pin PLCC, Common Functions**

Pin	Name	Type	Name/Description
1	DO	O	Serial Data Output. This is a 3-state output.
2	DI	I	Serial Data Input.
3	DCLK	I	Serial Data Clock Input.
4	CS	I	Chip Select Input. This lead determines the interval that the serial interface is active.
5	INTS	I	Serial Interface Select. Leaving this lead open places the serial interface in the normal mode; grounding it places the interface into the byte-by-byte mode. This lead has an internal pull-up.
6	FILTV	PWR	Frequency Synthesizer Power (5 V). This pin must be tied to V_{DD} .
7	PVCOIN	—	Internal Test Point. Do not connect to this lead.
8	PVCO	—	Internal Test Point. Do not connect to this lead.
9	PLLT	—	Synthesizer Test Point. Do not connect to this lead.
10	SGND	GND	Synthesizer Ground. Connect to digital ground. A common AGND, DGND, SGND plane is highly recommended.
16, 29, 38, 44	DGND	GND	Digital Ground. Logic ground and return for logic power supply. A common AGND, DGND, SGND plane is highly recommended.
17, 28, 35, 42	V_{DD}	PWR	Digital Power Supply (5 V).
36	FS	I	PCM Frame Strobe Input. This 8 kHz clock must be derived from the same source as BCLK.
37	BCLK	I	PCM Bit Clock Input. This lead is used to develop internal clocks for certain clock rates.
39	DX	O	PCM Transmit Data Output. This is a 3-state output.
40	DR	I	PCM Receive Data Input.
41	RST	I	Power-On Reset. A low causes a reset of the entire chip. This pin may be connected to DGND with a 0.1 μ F capacitor for a power-on reset function, or it may be driven by external logic. This lead has an internal pull-up.
43	NC	—	No Connect. This pin may be used as a tie point.

Pin Information (continued)

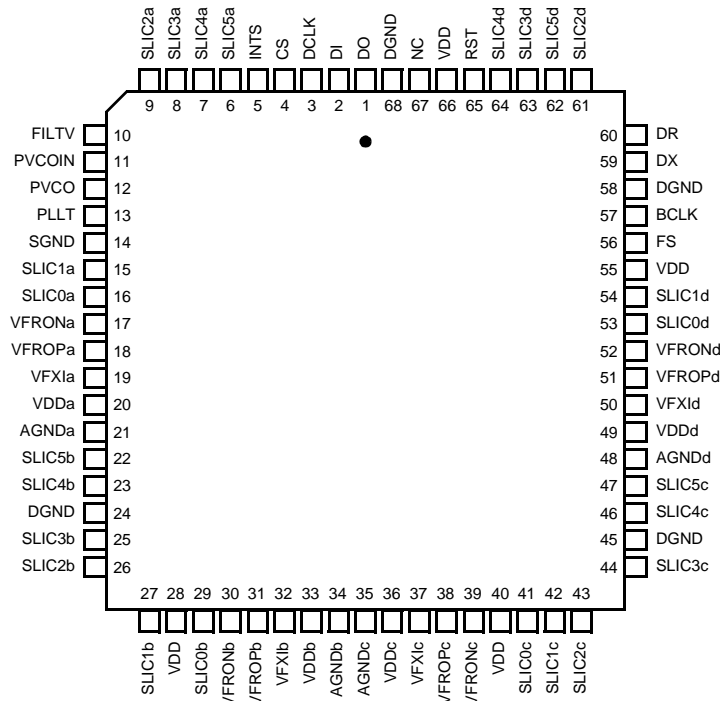

5-8126 (F)

Figure 3. 68-Pin PLCC Pin Diagram

Table 3. Pin Assignments, 68-Pin PLCC, Per-Channel Functions

Ckt				Name	Type	Name/Description
a	b	c	d			
21	34	35	48	AGND	GND	Analog Ground. A common AGND, DGND, SGND plane is highly recommended.
20	33	36	49	VDD	PWR	Analog Power Supply.
19	32	37	50	VFXI	I	Voice Frequency Transmit Input. This node requires a 10 MΩ or 20 MΩ resistance to AGND. The value is dependent upon the gain of the XAG amplifier (register 146). 20 MΩ can be used for any gain setting, 10 MΩ can only be used for XAG gain settings of 0 dB and +6.02 dB.
18	31	38	51	VFROP	O	Voice Frequency Receive Output, Positive Polarity. This pin can drive 2000 Ω (or greater) loads.
17	30	39	52	VFRON	O	Voice Frequency Receive Output, Negative Polarity. This pin can drive 2000 Ω (or greater) loads.
16	29	41	53	SLIC0	I/O	SLIC Control 0.
15	27	42	54	SLIC1	I/O	SLIC Control 1.
9	26	43	61	SLIC2	I/O	SLIC Control 2.
8	25	44	63	SLIC3	I/O	SLIC Control 3.
7	23	46	64	SLIC4	I/O	SLIC Control 4.
6	22	47	62	SLIC5	I/O	SLIC Control 5.

Pin Information (continued)**Table 4. Pin Assignments, 68-Pin PLCC, Common Functions**

Pin	Name	Type	Name/Description
1	DO	O	Serial Data Output. This is a 3-state output.
2	DI	I	Serial Data Input.
3	DCLK	I	Serial Data Clock Input.
4	CS	I	Chip Select Input. This lead determines the interval that the serial interface is active.
5	INTS	I	Serial Interface Select. Leaving this lead open places the serial interface in the normal mode; grounding it places the interface into the byte-by-byte mode. This lead has an internal pull-up.
10	FILTV	PWR	Frequency Synthesizer Power (5 V). This pin must be tied to V_{DD} .
11	PVCOIN	—	Internal Test Point. Do not connect to this lead.
12	PVCO	—	Internal Test Point. Do not connect to this lead.
13	PLLT	—	Synthesizer Test Point. Do not connect to this lead.
14	SGND	GND	Synthesizer Ground. Connect to digital ground. A common AGND, DGND, SGND plane is highly recommended.
24, 45, 58, 68	DGND	GND	Digital Ground. Logic ground and return for logic power supply. A common AGND, DGND, SGND plane is highly recommended.
28, 40, 55, 66	V_{DD}	PWR	Digital Power Supply (5 V).
56	FS	I	PCM Frame Strobe Input. This 8 kHz clock must be derived from the same source as BCLK.
57	BCLK	I	PCM Bit Clock Input. This lead is used to develop internal clocks for certain clock rates.
59	DX	O	PCM Transmit Data Output. This is a 3-state output.
60	DR	I	PCM Receive Data Input.
65	RST	I	Power-On Reset. A low causes a reset of the entire chip. This pin may be connected to DGND with a 0.1 μ F capacitor for a power-on reset function, or it may be driven by external logic. This lead has an internal pull-up.
67	NC	—	No Connect. This pin may be used as a tie point.

Pin Information (continued)

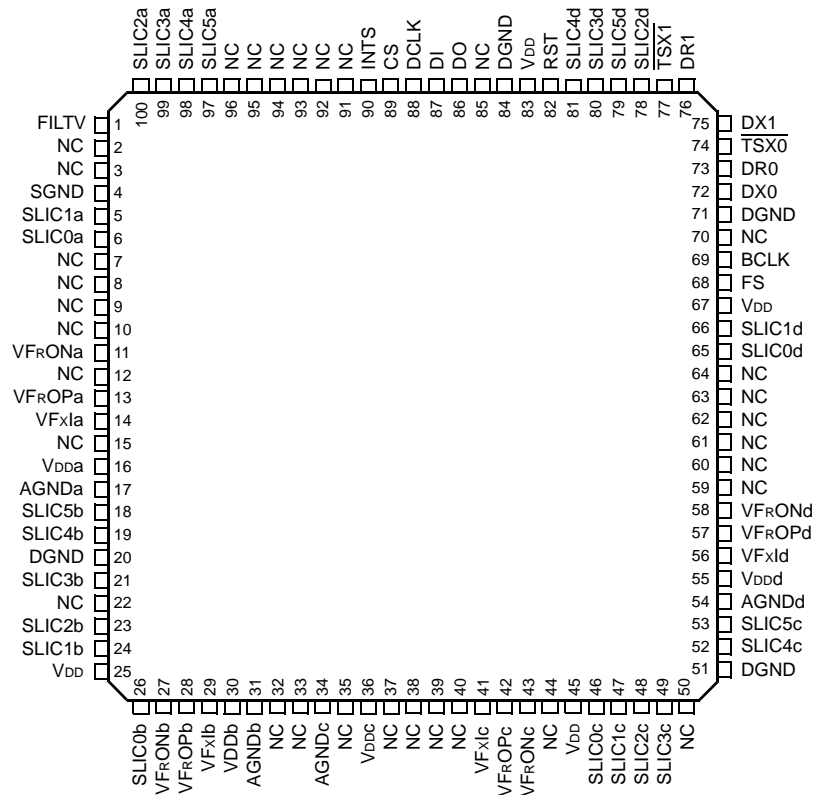

5-8885 (F)

Figure 4. 100-Pin TQFP Pin Diagram

Table 5. Pin Assignments, 100-Pin TQFP, Per-Channel Functions

Ckt				Name	Type	Name/Description
a	b	c	d			
17	31	34	54	AGND	GND	Analog Ground. A common AGND, DGND, SGND plane is highly recommended.
16	30	36	55	V _{DD}	PWR	Analog Power Supply.
14	29	41	56	VFxI	I	Voice Frequency Transmit Input. This node requires a 10 M Ω or 20 M Ω resistance to AGND. The value is dependent upon the gain of the XAG amplifier (register 146). 20 M Ω can be used for any gain setting, 10 M Ω can only be used for XAG gain settings of 0 dB and +6.02 dB.
13	28	42	57	VFR _{OP}	O	Voice Frequency Receive Output, Positive Polarity. This pin can drive 2000 Ω (or greater) loads.
11	27	43	58	VFR _{ON}	O	Voice Frequency Receive Output, Negative Polarity. This pin can drive 2000 Ω (or greater) loads.
6	26	46	65	SLIC0	I/O	SLIC Control 0.
5	24	47	66	SLIC1	I/O	SLIC Control 1.
100	23	48	78	SLIC2	I/O	SLIC Control 2.
99	21	49	80	SLIC3	I/O	SLIC Control 3.
98	19	52	81	SLIC4	I/O	SLIC Control 4.
97	18	53	79	SLIC5	I/O	SLIC Control 5.

Pin Information (continued)**Table 6. Pin Assignments, 100-Pin TQFP, Common Functions**

Pin	Name	Type	Name/Description
1	FILTV	PWR	Frequency Synthesizer Power (5 V). This pin must be tied to V _{DD} .
2, 3, 7—10, 12, 15, 22, 32, 33, 35, 37—40, 44, 50, 59—64, 70, 85, 91—96	NC	—	No Connect. This pin may be used as a tie point.
4	SGND	GND	Synthesizer Ground. Connect to digital ground. A common AGND, DGND, SGND plane is highly recommended.
20, 51, 71, 84	DGND	GND	Digital Ground. Logic ground and return for logic power supply. A common AGND, DGND, SGND plane is highly recommended.
25, 45, 67, 83	V _{DD}	PWR	Digital Power Supply (5 V).
68	FS	I	PCM Frame Strobe Input. This 8 kHz clock must be derived from the same source as BCLK.
69	BCLK	I	PCM Bit Clock Input. This lead is used to develop internal clocks for certain clock rates.
72	DX0	O	PCM Transmit Data Output 0. This is a 3-state output.
73	DR0	I	PCM Receive Data Input 0.
74	$\overline{\text{TSX0}}$	O	Backplane Line Driver Enable 0 (Active-Low). Normally, these open-drain outputs are floating in a high-impedance state. When a time slot is active on DX0, this output pulls low to enable a backplane line driver.
75	DX1	O	PCM Transmit Data Output 1. This is a 3-state output.
76	DR1	I	PCM Receive Data Input 1.
77	$\overline{\text{TSX1}}$	O	Backplane Line Driver Enable 1 (Active-Low). Normally, these open-drain outputs are floating in a high-impedance state. When a time slot is active on DX1, this output pulls low to enable a backplane line driver.
82	RST	I	Power-On Reset. A low causes a reset of the entire chip. This pin may be connected to DGND with a 0.1 μF capacitor for a power-on reset function, or it may be driven by external logic. This lead has an internal pull-up.
86	DO	O	Serial Data Output. This is a 3-state output.
87	DI	I	Serial Data Input.
88	DCLK	I	Serial Data Clock Input.
89	CS	I	Chip Select Input. This lead determines the interval that the serial interface is active.
90	INTS	I	Serial Interface Select. Leaving this lead open places the serial interface in the normal mode; grounding it places the interface into the byte-by-byte mode. This lead has an internal pull-up.

Pin Information (continued)

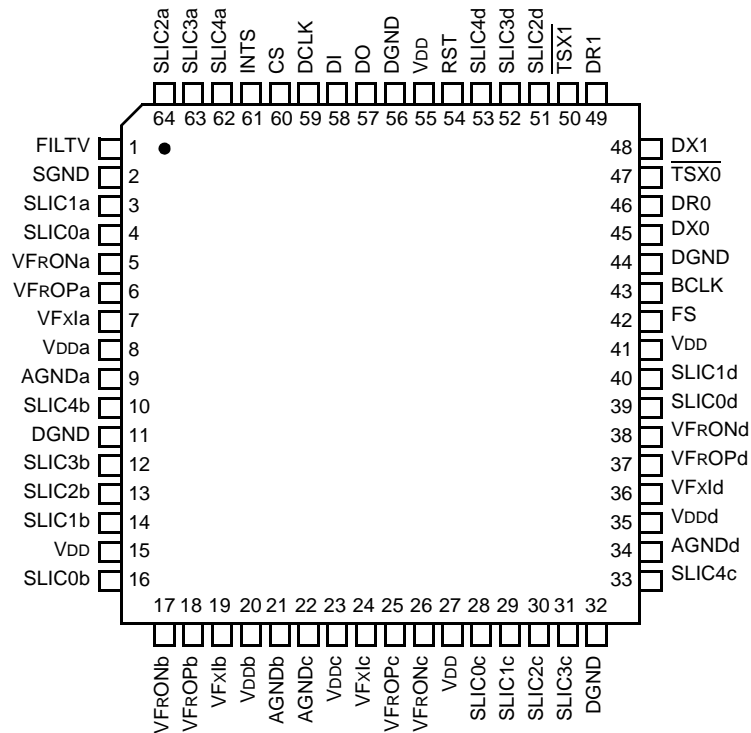

5-7187dF

Figure 5. 64-Pin TQFP Pin Diagram

Table 7. Pin Assignments, 64-Pin TQFP, Per-Channel Functions

Ckt				Name	Type	Name/Description
a	b	c	d			
9	21	22	34	AGND	GND	Analog Ground. A common AGND, DGND, SGND plane is highly recommended.
8	20	23	35	V _{DD}	PWR	Analog Power Supply.
7	19	24	36	VFXl	I	Voice Frequency Transmit Input. This node requires a 10 MΩ or 20 MΩ resistance to AGND. The value is dependent upon the gain of the XAG amplifier (register 146). 20 MΩ can be used for any gain setting, 10 MΩ can only be used for XAG gain settings of 0 dB and +6.02 dB.
6	18	25	37	VFROP	O	Voice Frequency Receive Output, Positive Polarity. This pin can drive 2000 Ω (or greater) loads.
5	17	26	38	VFRON	O	Voice Frequency Receive Output, Negative Polarity. This pin can drive 2000 Ω (or greater) loads.
4	16	28	39	SLIC0	I/O	SLIC Control 0.
3	14	29	40	SLIC1	I/O	SLIC Control 1.
64	13	30	51	SLIC2	I/O	SLIC Control 2.
63	12	31	52	SLIC3	I/O	SLIC Control 3.
62	10	33	53	SLIC4	I/O	SLIC Control 4.

Pin Information (continued)**Table 8. Pin Assignments, 64-Pin TQFP, Common Functions**

Pin	Name	Type	Name/Description
1	FILTV	PWR	Frequency Synthesizer Power (5 V). This pin must be tied to V _{DD} .
2	SGND	GND	Synthesizer Ground. Connect to digital ground. A common AGND, DGND, SGND plane is highly recommended.
11, 32, 44, 56	DGND	GND	Digital Ground. Logic ground and return for logic power supply. A common AGND, DGND, SGND plane is highly recommended.
15, 27, 41, 55	V _{DD}	PWR	Digital Power Supply (5 V).
42	FS	I	PCM Frame Strobe Input. This 8 kHz clock must be derived from the same source as BCLK.
43	BCLK	I	PCM Bit Clock Input. This lead is used to develop internal clocks for certain clock rates.
45	DX0	O	PCM Transmit Data Output 0. This is a 3-state output.
46	DR0	I	PCM Receive Data Input 0.
47	$\overline{\text{TSX0}}$	O	Backplane Line Driver Enable 0 (Active-Low). Normally, these open-drain outputs are floating in a high-impedance state. When a time slot is active on DX0, this output pulls low to enable a backplane line driver.
48	DX1	O	PCM Transmit Data Output 1. This a 3-state output.
49	DR1	I	PCM Receive Data Input 1.
50	$\overline{\text{TSX1}}$	O	Backplane Line Driver Enable 1 (Active-Low). Normally, these open-drain outputs are floating in a high-impedance state. When a time slot is active on DX1, this output pulls low to enable a backplane line driver.
54	RST	I	Power-On Reset. A low causes a reset of the entire chip. This pin may be connected to DGND with a 0.1 μF capacitor for a power-on reset function, or it may be driven by external logic. This lead has an internal pull-up.
57	DO	O	Serial Data Output. This is a 3-state output.
58	DI	I	Serial Data Input.
59	DCLK	I	Serial Data Clock Input.
60	CS	I	Chip Select Input. This lead determines the interval that the serial interface is active.
61	INTS	I	Serial Interface Select. Leaving this lead open places the serial interface in the normal mode; grounding it places the interface into the byte-by-byte mode. This lead has an internal pull-up.

Functional Description

Clocking Considerations

The PCM bus uses BCLK as the bit clock and the one-going edge of FS to determine the location of the beginning of a frame. These two clocks must be derived from the same source. Internally, the device develops all the internal clocks with a phase-locked loop that uses BCLK as the timing source. BCLK and FS must be continuously present and without gaps in order for the device to operate correctly.

DCLK is used to clock the internal serial interface and may be asynchronous to the other clocks. There is no need to derive this clock from the same source as the other clocks. The serial bus may be operated at any speed up to 4.096 Mbits/s. DCLK can be gapped. There is no limit on the number of devices on the same serial bus.

The Control Interface

The device is controlled via a series of memory locations accessed by a serial data connection to the external master controller. This interface operates using the chip select lead to enable transmission of information. All chip functions are enabled or disabled by setting or clearing bits in the control memory. Filter coefficients and gain adjustments are also stored in this memory.

The codec has both a serial input lead and a serial output lead. These may be used individually for a 4-wire serial interface, or tied together for a 2-wire interface. The line driver circuitry is capable of driving relatively high currents so that in the event that the line is long enough to show significant transmission line effects, it can be terminated in the characteristic impedance at each end with resistors to V_{CC} and ground.

All data transfers on the serial bus are byte oriented with the least significant bit (shown in this data sheet as bit 0) transmitted first, followed by the more significant bits. For data fields, the least significant byte of the first data byte is transmitted first, followed by the more significant bytes, each byte transmitted LSB first. This format is compatible with the serial port on most microcontrollers.

Modes

There are two different modes of operation for the serial interface: the normal mode and the byte-by-byte mode. These two modes differ in the data clocking and the manner in which CS is used to control the transfer. Note that the CS lead is used to control the transfer of serial data from master controller to slave codec and in the reverse direction.

In normal mode (INTS pin open), the CS lead must go low for the duration of the transfer. CS is latched by DCLK on a positive-going clock edge. DI is latched by DCLK on a negative-going clock edge. DCLK may be continuous, but only needs to be present to clock data when CS is low (gapped clock). When using gapped clock, DCLK can remain high or low when CS is high. The only error check performed by the codec is to verify that CS is low for an integral number of bytes. Detection of an active chip select for other than an integral multiple of 8 bits results in the operation being terminated. The next active excursion of chip select will be interpreted as a new command; hence, the serial I/O interface can always be initialized by asserting CS for a number of clock periods that is not an integral multiple of 8. CS is captured using DCLK, so DCLK must be transitioned to perform this initialization.

The byte-by-byte mode (INTS pin tied to ground) uses CS to control each byte of the transfer. In this mode, CS goes low for exactly 8 bits at a time, corresponding to a 1-byte transfer either to or from the codec chip. DCLK can be continuous or gapped. When using a gapped clock, DCLK can remain high or low when CS is high. CS and DI are latched on a positive-going clock edge. Repeated transitions of CS are used to control subsequent bytes of data to/from the codec. For a write command in this mode, CS must go low for each byte of the transfer until the transfer is complete. For a read command, CS will go low for each of the 3 bytes of the read command transferred to the device, then low again for each byte to be read. Notice that the total number of bytes transferred (and excursions on CS) is $N + 3$, where N is the number of bytes to be read in the command. This mode of operation is useful in cases where the master is a microprocessor with a built-in UART that transfers 1 byte at a time. Error detection is limited to detection of an active CS for other than an integral multiple of 8 bits. Recovery is the same as normal mode.

Flow control can be accomplished by suspending the transitions on DCLK by holding either state. During the data transfer, CS must remain low while clock transitions are suspended with DCLK in either state.

Functional Description (continued)

The Control Interface (continued)

Protocol

The format of the command protocol is shown in Figures 6 and 7.

The control interface operates with one external master controller and multiple slave codec devices. Each transfer is initiated by the master, and the slave responds for either read operations or the fast scan mode. The slave does not check the bus for activity prior to transmitting; it only checks for an active CS. The master should allow for a wait between the end of a read command until CS becomes active for the read data. The master must refrain from sending additional commands to the slave chip until the response is received. On a 4-wire bus, commands to other devices may be initiated before the response is received, but care in generating the CS function is needed to ensure that the multiple responses do not interfere. It should be noted that multiple memory locations can be accessed in the same command by setting the data

field length field to the desired number of bytes to be transferred. If flow control is desired, it must be performed by using separate commands, each transferring smaller blocks of information, or by controlling the serial clock (gapping the serial clock), or with CS in the case of byte-by-byte mode.

There is no response from the slave to the master for a write operation. The response to a read operation simply includes the data to be read in the data field. Commands from the master controller include data for write operations, but not for read operations.

All data is transmitted in a byte-oriented fashion with the least significant bit of each byte transferred first. Multibyte fields are transferred least significant byte first in both directions. The data field will contain the first addressed data location first, with subsequent data locations transmitted in ascending order.

Since the coefficients and gains are stored in volatile memory, all the coefficients and gains must be loaded after powerup. There is, however, no need to reload them when switching from active to standby modes, or vice versa.

Functional Description (continued)

The Control Interface (continued)

Protocol (continued)

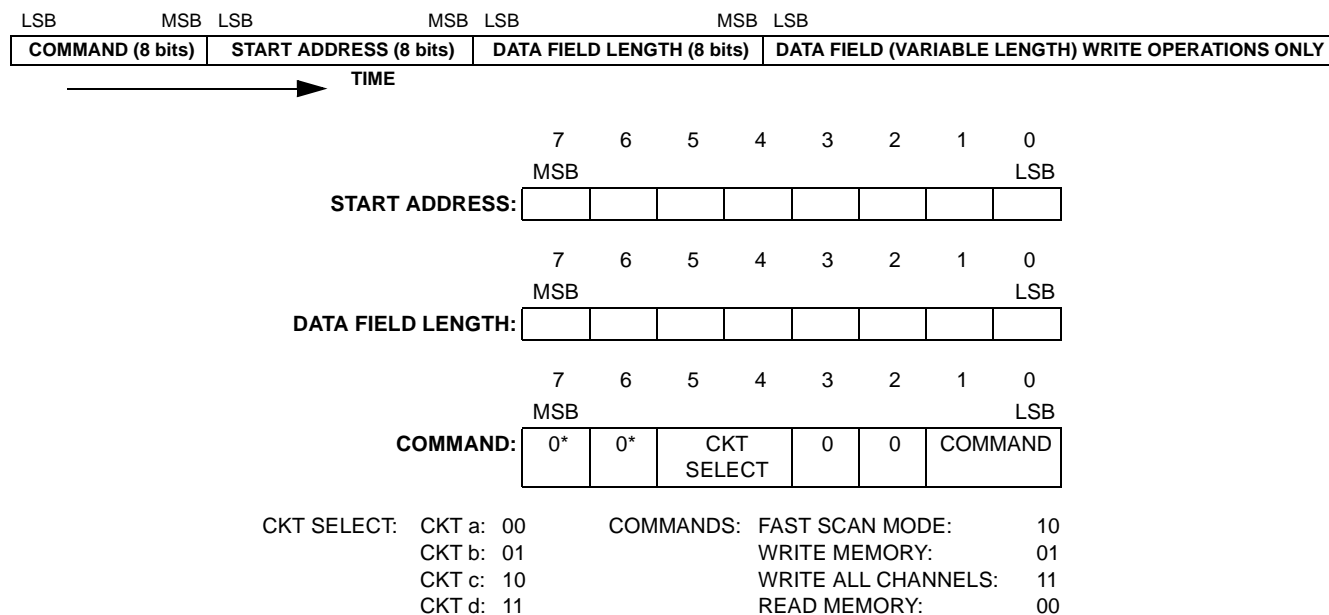

* Location of memory bank selection. All user controls are in memory bank 0; other memory banks contain internal state information for the device.

Note: Data field length is in bytes for all operations. All data is transmitted in bytes with the LSB for each byte transmitted first. For 16-bit memory operations, the least significant byte of the first memory location is transmitted first, followed by the most significant byte; each byte is transmitted LSB first. Additional memory locations are loaded in ascending sequence.

Figure 6. Command Frame Format, Master to Slave, Read or Write Commands



Note: All data is transmitted in bytes with the LSB for each byte transmitted first. For memory operations, the least significant byte of the first memory location is transmitted first, followed by the most significant byte, each byte transmitted LSB first. Additional memory locations are loaded in ascending sequence.

Figure 7. Command Frame Format, Slave to Master, Read Commands

Functional Description (continued)

The Control Interface (continued)

Write Command

A write command is used to write to the memory addresses. Figures 8—11 illustrate normal or byte-by-byte operation with continuous or gapped DCLKs. For gapped DCLK operation, transitions, not frequency, are critical (as long as the transitions do not exceed the maximum DCLK frequencies).

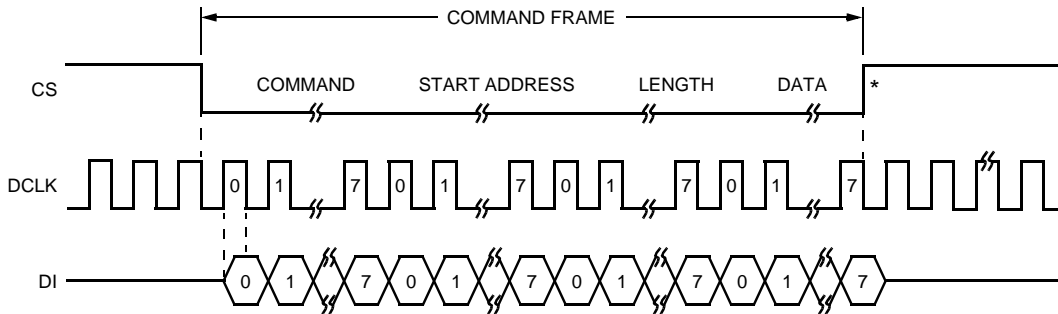

0078B

* Allow a minimum of 244 ns before the next command frame.

Note: Data field length of 1 shown.

Figure 8. Write Operation, Normal Mode (Continuous DCLK)

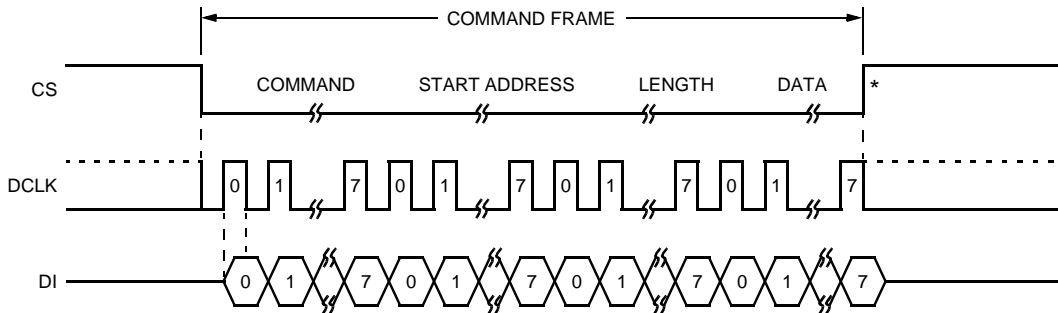

0078C

* Allow a minimum of 244 ns before the next command frame.

Note: Data field length of 1 shown.

Figure 9. Write Operation, Normal Mode (Gapped DCLK)

Functional Description (continued)

The Control Interface (continued)

Write Command (continued)

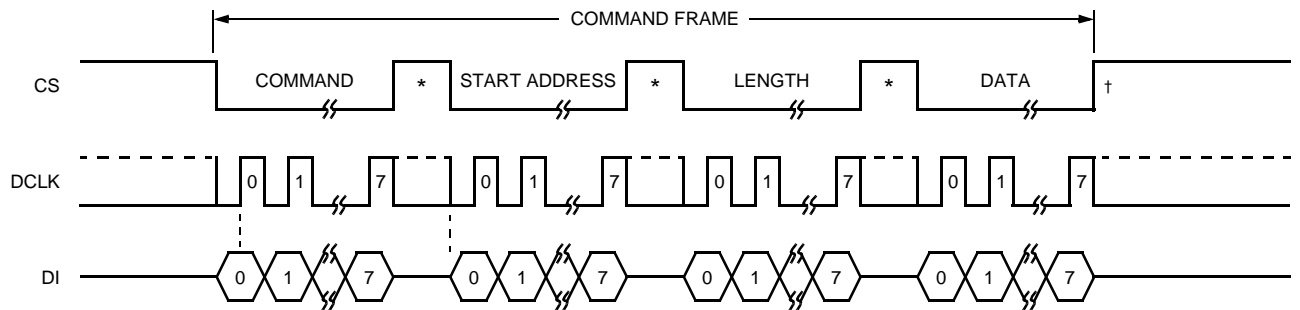

0072C

* Shows customary usage, CS not required to go high between bytes.

† Allow a minimum of 244 ns before the next command frame.

Note: Data field length of 1 shown.

Figure 10. Write Operation, Byte-by-Byte Mode (Gapped DCLK)

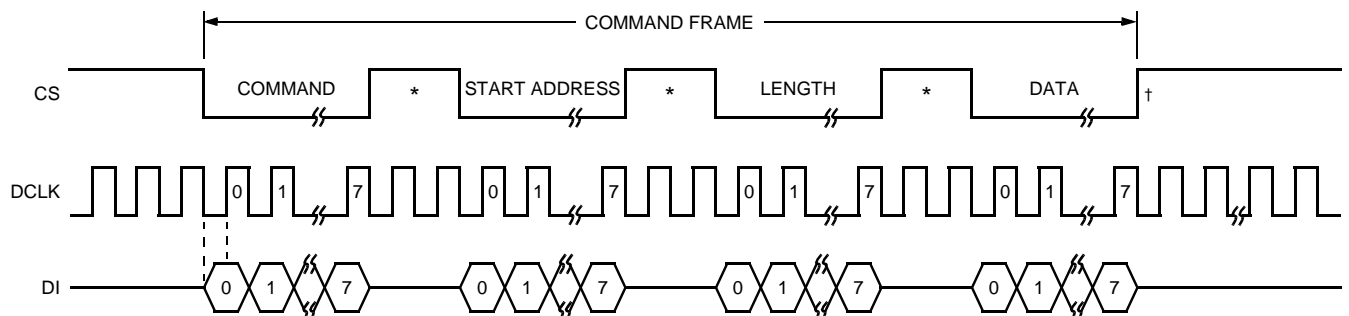

0074B

* Shows customary usage, CS not required to go high between bytes.

† Allow a minimum of 244 ns before the next command frame.

Note: Data field length of 1 shown.

Figure 11. Write Operation, Byte-by-Byte Mode (Continuous DCLK)

Functional Description (continued)

The Control Interface (continued)

Read Command

The normal flow of information to the master controller is always in response to a read command. All control memory locations are accessed in 8-bit bytes. All read commands from the master controller require a response from the addressed codec. It is the responsibility of the master controller to ensure that only one device is transmitting on the serial interface line at any one time. The master controller also must ensure that the CS lead goes high after transferring the 3-byte sequence used to initiate the read, and then it goes low again for the response. In this case, it should be noted that the device expects that the second time CS goes low the data is to be sent to the master; thus, it does not interpret the DI lead as containing a valid instruction during that CS excursion and a write during this time is not recommended. Note also that the CS lead must allow the number of bytes sent in a read command to be transferred before a subsequent command can be received by the codec. Figures 12—15 illustrate normal or byte-by-byte operation with continuous or gapped DCLKs. Like a write command, transitions, not frequency, are critical with regard to DCLK operation.

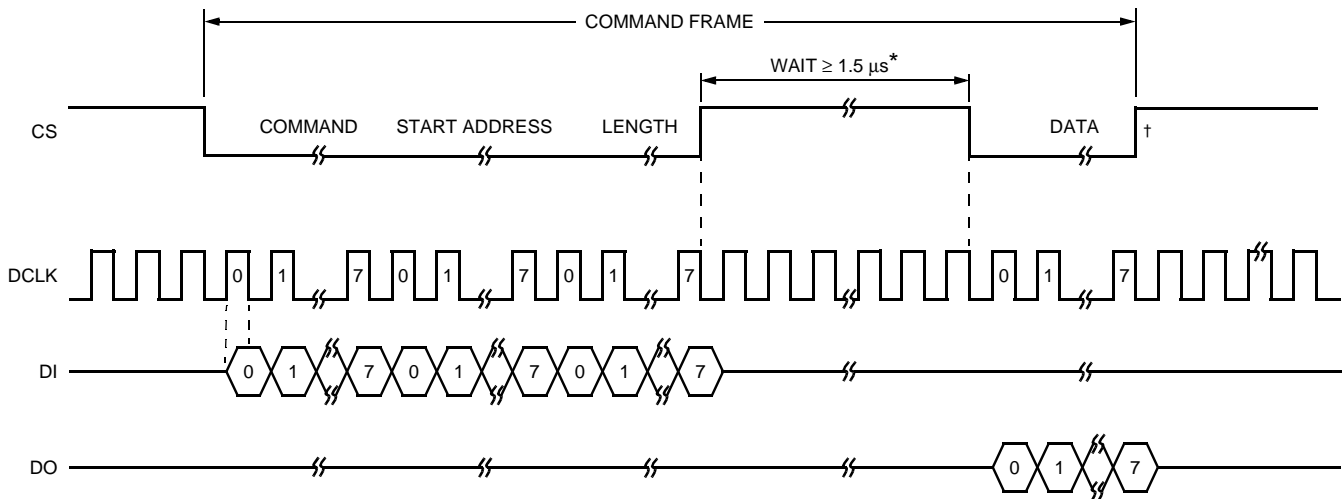

0079B

* Provides sufficient wait time to access read data.
 † Allow a minimum of 244 ns before the next command frame.
 Note: Data field length of 1 shown.

Figure 12. Read Operation, Normal Mode (Continuous DCLK)

Functional Description (continued)

The Control Interface (continued)

Read Command (continued)

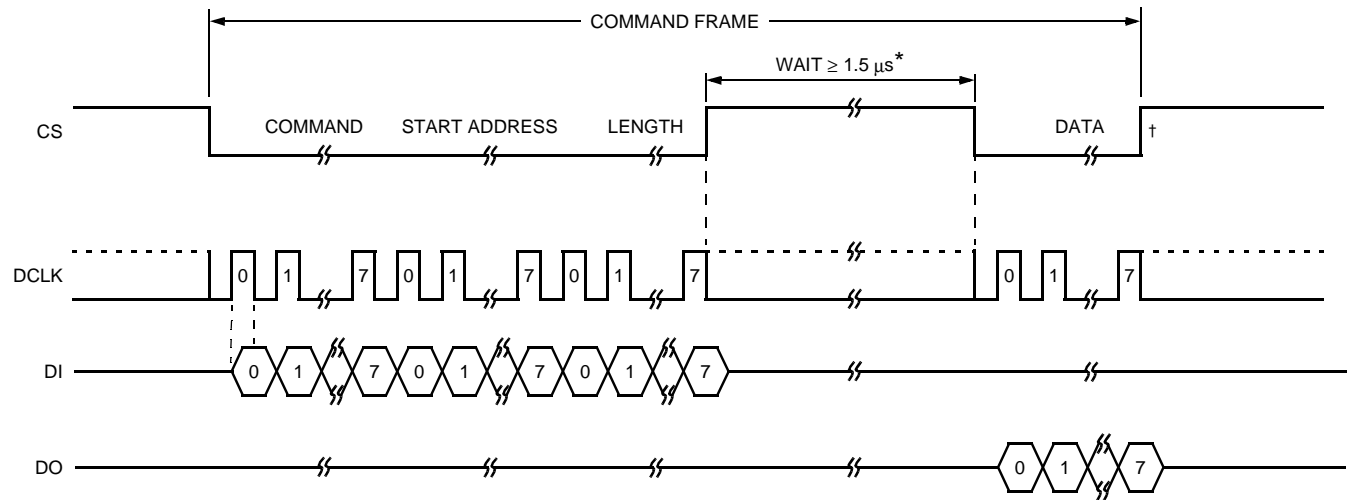

0079C

- * Provides sufficient wait time to access read data.
- † Allow a minimum of 244 ns before the next command frame.

Figure 13. Read Operation, Normal Mode (Gapped DCLK)

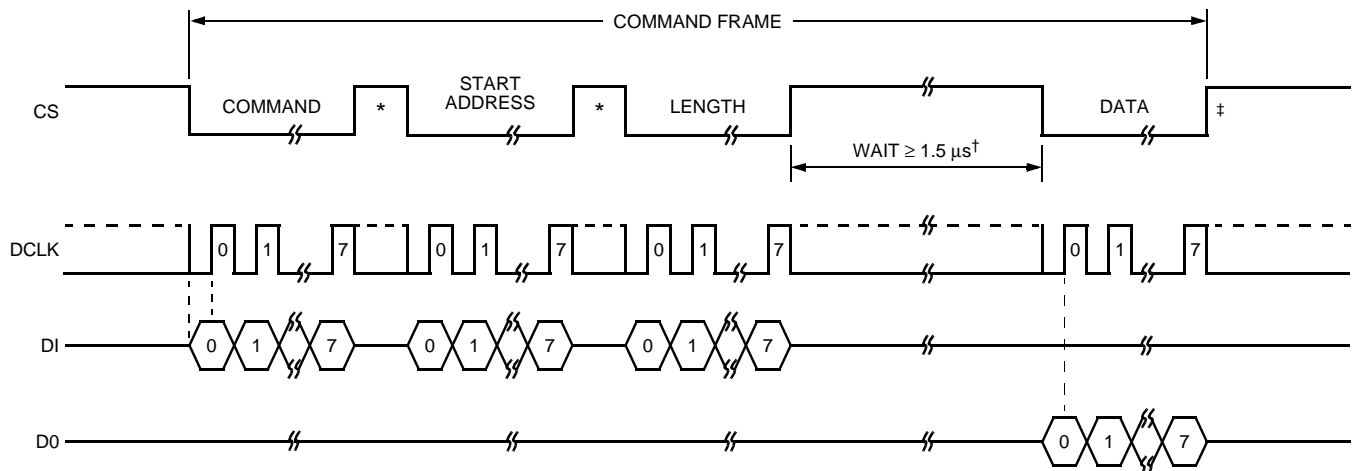

0073C

- * Shows customary usage, CS not required to go high between bytes.
- † Provides sufficient wait time to access read data.
- ‡ Allow a minimum of 244 ns before the next command frame.

Note: Data field length of 1 shown.

Figure 14. Read Operation, Byte-by-Byte Mode (Gapped DCLK)

Functional Description (continued)

The Control Interface (continued)

Read Command (continued)

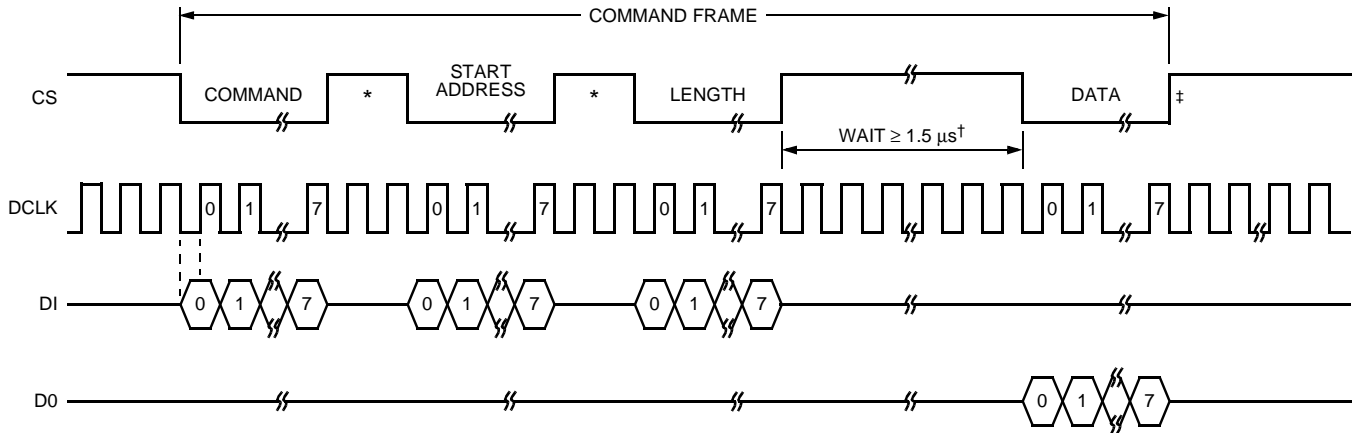

0075B

* Shows customary usage, CS not required to go high between bytes.

† Provides sufficient wait time to access read data.

‡ Allow a minimum of 244 ns before the next command frame.

Note: Data field length of 1 shown.

Figure 15. Read Operation, Byte-by-Byte Mode (Continuous DCLK)

Fast Scan Mode

The fast scan mode allows a single byte command to read two SLIC control leads for all four channels with a 1-byte reply. This mode significantly speeds up the normal scanning for off-hook, ring trip, and ring ground detection. This special command sequence allows the controlling microprocessor to fast scan 2 bits in the SLIC control byte of each of the four channels. The command code is (00000010)₂; there are no start address or length fields. The command returns only a single byte of data, formatted as shown in Table 9.

Table 9. Bit Assignments for Fast Scan Mode

Bit	Reported Status
0 (LSB)	Channel 0, bit 0 (ckt a, address 160, bit 0)
1	Channel 0, bit 1 (ckt a, address 160, bit 1)
2	Channel 1, bit 0 (ckt b, address 160, bit 0)
3	Channel 1, bit 1 (ckt b, address 160, bit 1)
4	Channel 2, bit 0 (ckt c, address 160, bit 0)
5	Channel 2, bit 1 (ckt c, address 160, bit 1)
6	Channel 3, bit 0 (ckt d, address 160, bit 0)
7 (MSB)	Channel 3, bit 1 (ckt d, address 160, bit 1)

Functional Description (continued)

The Control Interface (continued)

Fast Scan Mode (continued)

The circuit select in the command structure (Figure 6) is not used for this special single-byte command. The rules for toggling chip select apply as for the read command. Figures 16—19 illustrate normal or byte-by-byte operation with continuous or gapped DCLKs.

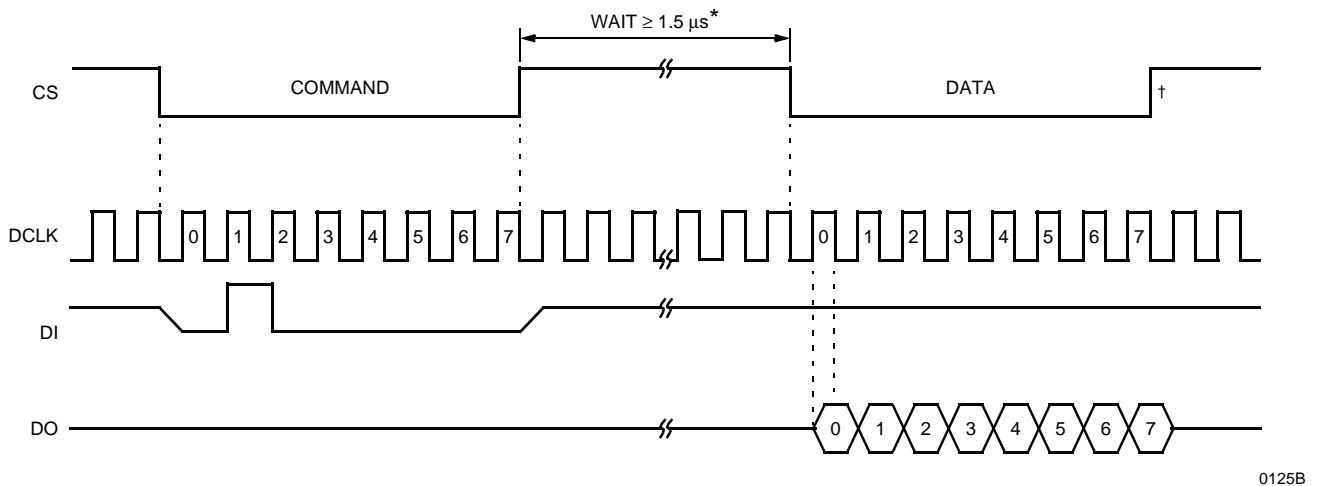

* Provides sufficient wait time to access read data.
† Allow a minimum of 244 ns between bytes.

Figure 16. Fast Scan, Normal Mode (Continuous DCLK)

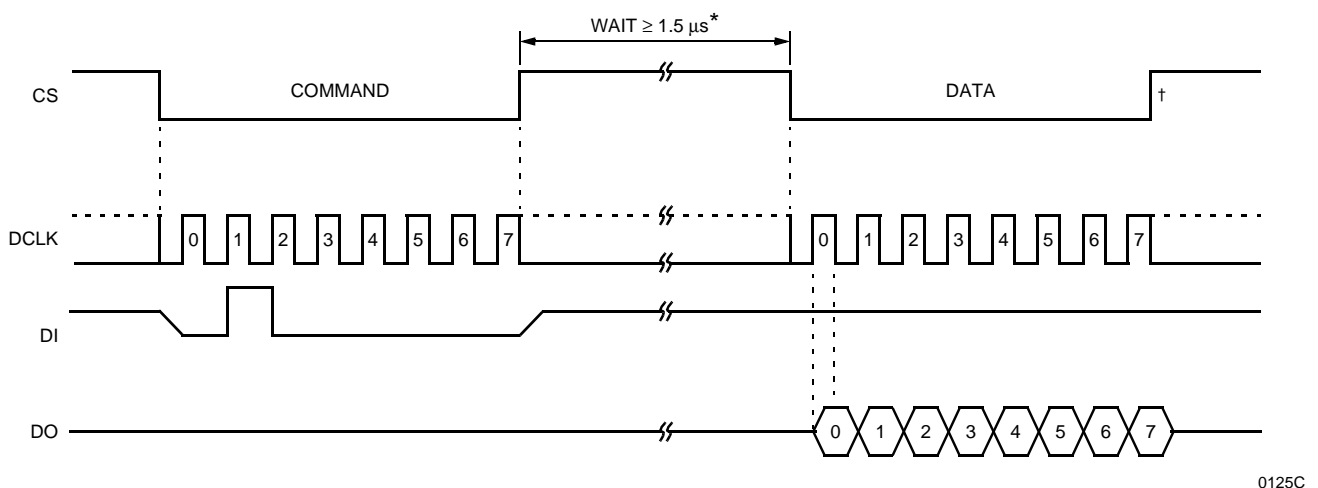

* Provides sufficient wait time to access read data.
† Allow a minimum of 244 ns between bytes.

Figure 17. Fast Scan, Normal Mode (Gapped DCLK)

Functional Description (continued)

The Control Interface (continued)

Fast Scan Mode (continued)

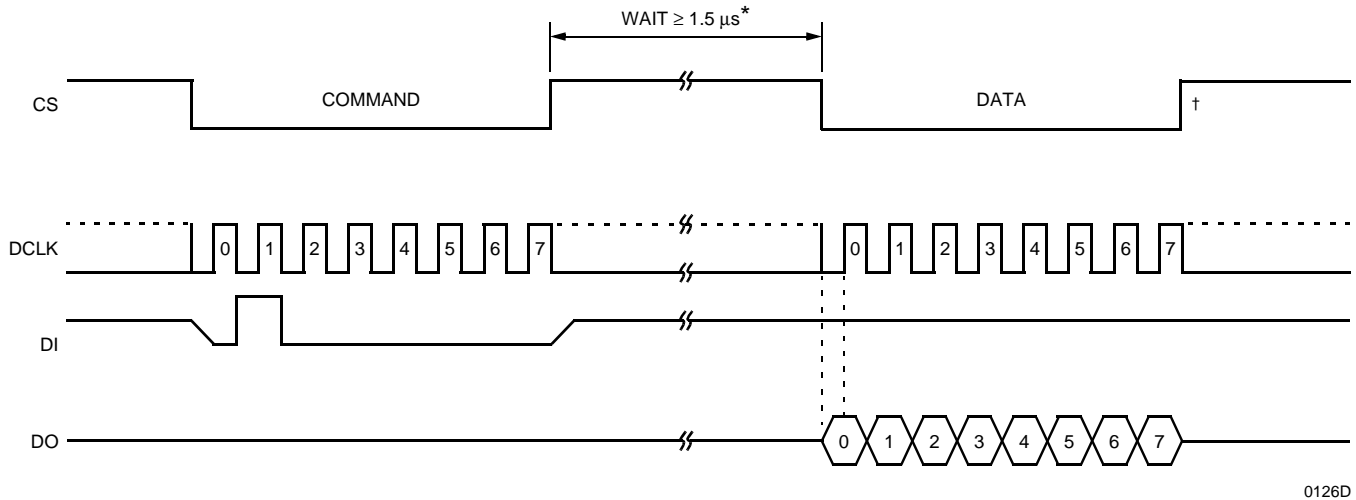

0126D

* Provides sufficient wait time to access read data.

† Allow a minimum of 244 ns between bytes.

Figure 18. Fast Scan, Byte-by-Byte Mode (Gapped DCLK)

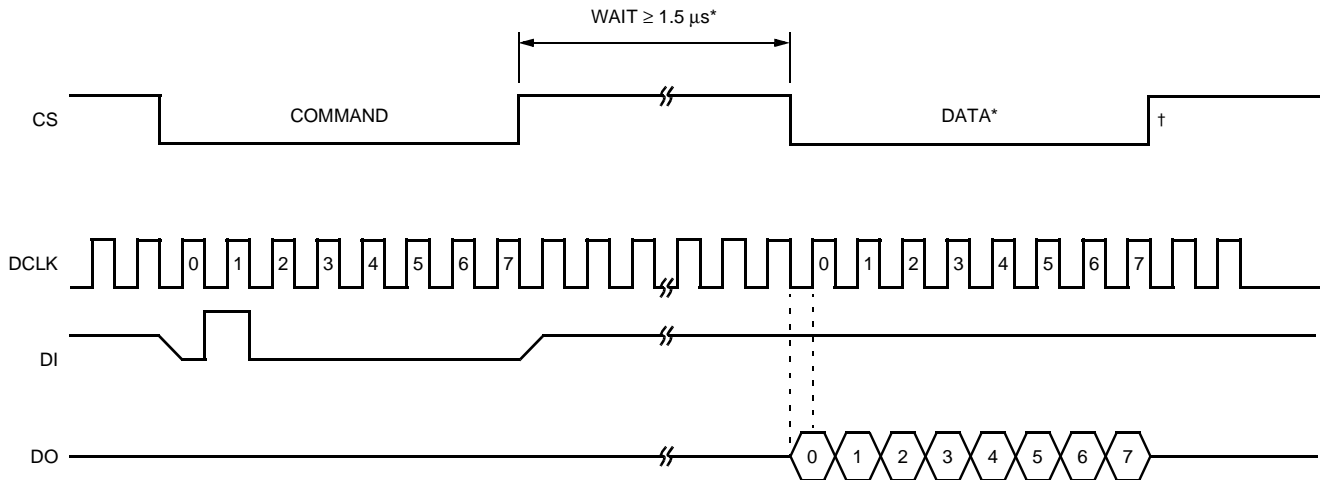

0124C

* Provides sufficient wait time to access read data.

† Allow a minimum of 244 ns between bytes.

Figure 19. Fast Scan, Byte-by-Byte Mode (Continuous DCLK)

Functional Description (continued)

The Control Interface (continued)

Write All Channels

The write all channels command causes all four channels to be loaded with the same coefficients with a single data transfer from the master controller. This allows for a faster initialization of the device after a powerup. This command should be used with caution since it affects all four channels. The normal memory write and read commands affect only one channel.

Reset Functionality

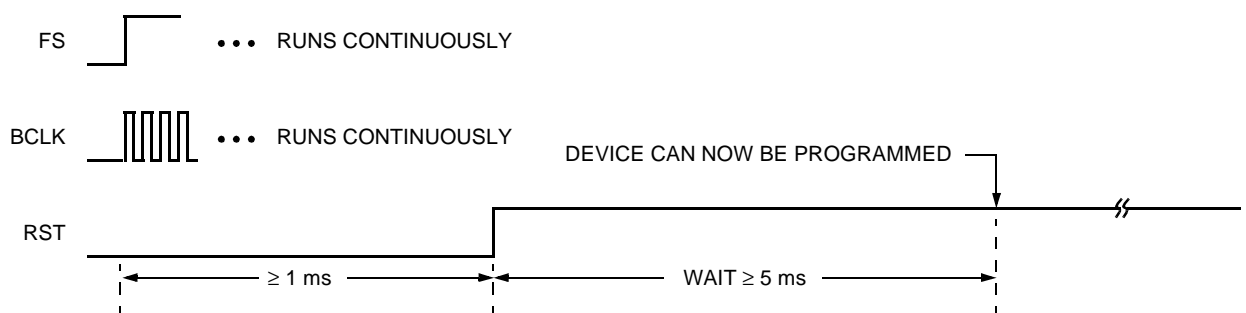

0071c

Figure 20. Hardware Reset Procedure

The reset function allows the internal logic of the device to be set to a known initial condition, either externally by activating the reset lead, or on a per-channel basis through the microprocessor interface by setting and then clearing bits, if required, in address RESCTRL (address 128). These two reset functions have different effects, and each of the software reset functions is a subset of the hardware reset functionality. The primary difference is in the treatment of the internal memory. The hardware reset is assumed to be a result of a catastrophic hardware event, such as a loss of power, loss of BCLK, or an initial powerup. Accordingly, the assumption is made that the internal memory does not contain valid data, and default values for all memory locations are loaded. A software reset, however, can only be initiated if the device is operational (at least the microprocessor interface), so the contents of the memory may indeed be valid; thus, the resets may be more specific. Additionally, software resets only affect the selected channel.

Functional Description (continued)

Reset Functionality (continued)

A 0.1 μF capacitor between the RST lead and ground will effectively hold the lead low long enough to reset the device on powerup, allowing for a cost-effective power-on reset function. Notice that the memory must be reloaded through the serial interface after a hardware reset function. For proper operation, it is necessary for FS and BCLK to be present and stable during a reset. A wait period for the internal PLL to stabilize is required after reset goes high. See the timing diagram shown in Figure 20 for the proper hardware or power-on reset procedure.

For a software reset, the control memory should not be accessed for a minimum of 256 μs following the reset.

Memory Control Mapping

Several memory locations are used to control the device. The software interface tables (Table 20, Memory Mapping, and Table 21, Control Bit Definition) show the memory assignments that are useful in call processing and system testing. It should be noted that other memory locations are used by the device to hold intermediate results and other device state information. Writing to these other locations can cause serious disruptions in the operation of the device and should be avoided.

Standby Mode

The device enters a low-power standby mode with powerup or software reset, or by programming the CHACTIVE register 129, bit 0. In standby mode, the control interface is active, capable of writing or reading registers. SLIC read and write data latches are also active. Analog signals at VFxI and PCM signals at D_R are ignored in this mode. BCLK must be present for proper standby mode operation.

Test Capabilities

The device has several built-in test capabilities that can be used to verify correct operation of the signal processing of the line card. These test functions are accessed in several different control addresses. Five loopback modes are employed: the first for the digital signal from the PCM bus to be looped back to the PCM bus. This loopback facility can be used to verify correct operation of the PCM bus interface logic, as well as operation of the PCM bus. The second digital loopback function allows complete testing of the digital processing capability of the codec by looping the data back at the analog/digital conversion interface. The third loopback function can be used to check the operation of all the signal processing performed in the device, including the conversions to/from analog. These digital loopback functions can be used with tone generation and reception via the PCM bus.

The first analog loopback facility is at the digital side of the delta-sigma converters and loops analog transmit data back to the analog receive path. The second analog loopback is at the PCM bus interface and loops the transmit data from the line back to the receive path.

By assigning the transmit and receive time slots identically, a loopback arrangement at the PCM bus can be effectively programmed for signals generated on the line side of the codec. This mode is useful for testing from the line side through the entire device.

SLIC Control Capabilities

Memory locations 158, 159, and 160 are used to control six bidirectional latches that are intended to allow the serial interface to control other line card devices, such as ringing/test switches, telecom electromechanical relays, and SLIC devices. When the TTL latches are configured as outputs, external devices should be set up to sink current from the latch. Location 158 sets the operational mode of these latches as either inputs or outputs. Location 159 specifies what is to be written on the latch leads driven by the device. Location 160 reports the actual state of these leads. It should be noted that a channel control reset forces all of these external leads, except those corresponding to bits 2 and 3, to the high-impedance state, so any inputs connected to bits 0, 1, 4, and 5 should have appropriate pull-up or pull-down resistors (off-chip, if required) to force the external device into a known state at powerup or in the event of a reset. Bits 2 and 3 will reset to outputs with a value of zero.

Functional Description (continued)

SLIC Control Capabilities (continued)

The fast scan mode allows for a minimal data transfer on the serial bus to monitor bits 0 and 1 of the SLIC data memory location (159). If these two bits are wired as inputs to the off-hook and/or ring ground detection circuits, a convenient method of rapidly scanning for these two functions is obtained. Bits 2 and 3 default to outputs; thus, they are convenient to provide control of the SLIC state. In any event, all six leads are programmable for maximum flexibility.

Suggested Initialization Procedures

It is suggested that upon powerup, a hardware reset be used to set the device into a known state. The serial interface should then be used to load the memory addresses that differ from the default values (the write all channels command is convenient for this function). If other devices are controlled by the SLIC data memory location, then it also should be loaded with a known configuration. After the completion of this sequence, the device is ready to be activated. Depending on the application, the next step may either be normal operation or a set of test sequences. After the initialization of the memory, the device and associated line card devices can be controlled by using memory locations

130, 131, 145, 155, 156, 157, 158, 159, and 129; that is, by supplying the PCM bus time-slot addresses, switching the SLIC into the proper mode, and activating the codec. Within memory location 129, the codec would normally be placed into active mode, with both directions of the PCM bus enabled at the start of a call. At the completion of a call, the codec should be placed into standby mode and the PCM bus disabled. Great caution should be used when changing the memory while the codec is in active mode, since termination impedances, balance impedances, and gains may change. These changes are likely to yield undesirable system effects. It is safe to refresh coefficients that are known to be unchanging in the application. It is always possible to read the memory to verify its contents without deleterious effects on codec operation. Normal operation would load the memory and perform all gain adjustments while the codec is in standby mode. Under no circumstances should memory above address 162 be written, since this section of memory is used for state data and intermediate results. Also, all reserved addresses should not be written. Changing this information may have deleterious effects on system operation.

Signal Processing

Figure 21 details the signal processing functional blocks of one channel of the codec.

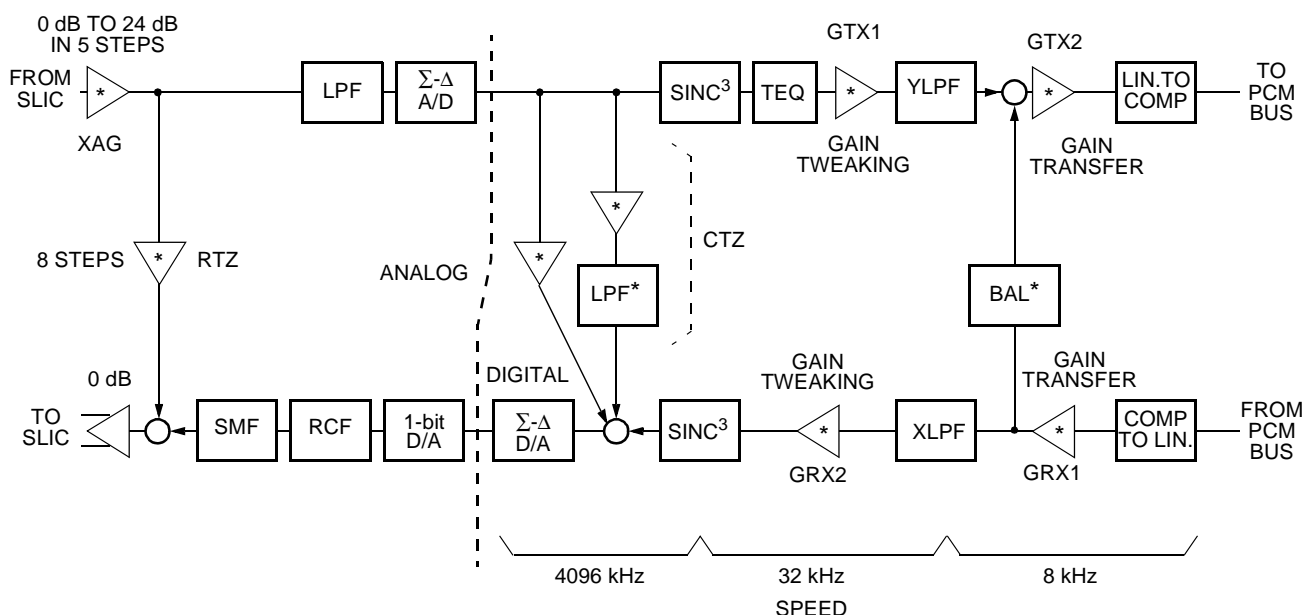

* Programmable blocks.

Figure 21. Internal Signal Processing

Absolute Maximum Ratings

Stresses in excess of the absolute maximum ratings can cause permanent damage to the device. These are absolute stress ratings only. Functional operation of the device is not implied at these or any other conditions in excess of those given in the operational section of the data sheet. Exposure to absolute maximum ratings for extended periods can adversely affect device reliability.

Parameter	Symbol	Min	Max	Unit
Storage Temperature Range	T _{stg}	-55	150	°C
Power Supply Voltage (all leads designated power)	V _{DDX}	—	6.5	V
Negative Voltage on Any Lead with Respect to Ground	V _{SS}	-0.25	—	V
Thermal Resistance, Junction to Ambient:				
68-Pin PLCC ¹	R _{θJA}	—	43	°C/W
44-Pin PLCC ¹	R _{θJA}	—	49	°C/W
64-Pin TQFP ²	R _{θJA}	—	40	°C/W
100-Pin TQFP ²	R _{θJA}	—	30	°C/W
Package Power Dissipation	P _D	—	1	W
SLIC Control Interface Latches, Current per Device	I _L	—	160	mA

1. Sparse copper, one layer test board.

2. Four layer, JEDEC test board.

Operating Ranges

Parameter	Symbol	Min	Max	Unit
Ambient Operating Temperature	T _A	-40	85	°C
Operating Junction Temperature	T _J	-40	125	°C
Power Supply Voltage (all leads designated power)	V _{DDX}	4.75	5.25	V

Handling Precautions

Although protection circuitry has been designed into this device, proper precautions should be taken to avoid exposure to electrostatic discharge (ESD) during handling and mounting. Agere Systems Inc. employs a human-body model (HBM) and a charged-device model (CDM) for ESD-susceptibility testing and protection design evaluation. ESD voltage thresholds are dependent on the circuit parameters used to define the model. No industry-wide standard has been adopted for the CDM. A standard HBM (resistance = 1500 Ω, capacitance = 100 pF) is widely accepted and can be used for comparison.

HBM ESD Threshold Voltage	
Device	Voltage
T8535B/T8536B	>2000

Electrical Characteristics

For all specifications: $T_A = -40\text{ }^\circ\text{C}$ to $+85\text{ }^\circ\text{C}$, $V_{DD} = 5\text{ V} \pm 5\%$, unless otherwise noted. Typical values are for $T_A = 25\text{ }^\circ\text{C}$ and $V_{DD} = 5\text{ V}$. Input signal frequency is 1004 Hz, BCLK = 16.384 MHz, DCLK = 4.096 MHz, and coefficients are at default values, unless otherwise noted.

dc Characteristics

Table 10. dc Characteristics

Parameter	Symbol	Test Conditions	Min	Typ	Max	Unit
Input Voltage Low	V_{IL}	All inputs	—	—	0.8	V
Input Voltage High	V_{IH}	All inputs	2.0	—	—	V
Input Current	I_{IL}	Digital, without pull-up, inputs, $GND < V_{IN} < V_{DD}$	-10	—	10	μA
		With internal pull-up, $V_{IN} = GND$ (INTS and RST leads)	-240	—	10	μA
		With internal pull-up, $V_{IN} = V_{DD}$ (INTS and RST leads)	-10	—	10	μA
Output Voltage Low: All Outputs SLIC Controls, Configured as Outputs	V_{OL}	$I_L = 3.2\text{ mA}$	—	—	0.4	V
	V_{OL}	$I_L = 24\text{ mA}$	—	—	1.0	V
Output Voltage High	V_{OH}	$I_L = -320\text{ }\mu\text{A}$	3.5	—	—	V
Output Current in High-impedance State	I_{OZ}	—	-30	—	30	μA
Line Driver (DX and DO leads) Output Voltage High	V_{OH}	$I_L = -10\text{ mA}$	$V_{DD} - 0.5$	—	—	V
Line Driver (DX and DO leads) Output Voltage Low	V_{OL}	$I_L = 10\text{ mA}$	—	—	1.0	V

Electrical Characteristics (continued)**Analog Interface**

The following specifications pertain to the analog SLIC interface for each channel.

Table 11. Analog Interface

Parameter	Symbol	Test Conditions	Min	Typ	Max	Unit
Input Resistance	R_{VFXI}	$0.25 < V_{IN} < (V_{DDX} - 0.25) \text{ V}$.	100	—	300	$k\Omega$
dc Input Voltage	V_{VFXI}	Relative to ground. Signal should be capacitively coupled to V_{FXI} .	1.8	2.0	2.2	V
Load Resistance at V_{FRON} and V_{FROP} (differential)	R_L	 5-8881F	7.5	—	—	$k\Omega$
Output Resistance	R_o	Digital input code corresponding to idle PCM code (μ -law).	—	2	10	Ω
Output Offset Voltage Between V_{FROP} and V_{FRON}	V_{OS}	Digital input code corresponding to idle PCM code (μ -law).	-100	0	100	mV
Output Offset Voltage Between V_{FROP} and V_{FRON} , Standby Mode	V_{OSS}	$R_L = 100 \text{ k}\Omega$.	-20	0	20	mV
Common-mode Output Voltage, Active Mode	V_{OCM}	Digital input code corresponding to alternating \pm zero μ -law PCM code.	—	2.0	—	V
Common-mode Output Voltage, Standby Mode	V_{OCMS}	—	1.7	2.0	2.3	V

Table 12. Power Dissipation

Power measurements are made at $BCLK = 2.048 \text{ MHz}$, $DCLK = 2.048 \text{ MHz}$, no inputs from serial interface, interface latches set as outputs, and outputs unloaded.

Parameter	Symbol	Test Conditions	Min	Typ	Max	Unit
All Channels in Standby, Dissipation for One Channel	I_{DD5}	—	—	22	28	mW
One Channel Active, Dissipation for Active Channel	I_{DD1}	—	—	225	—	mW
Four Channels Active, Dissipation for One Channel	I_{DD1}	—	—	90	125	mW

Electrical Characteristics (continued)

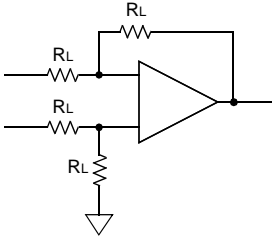
Gain and Dynamic Range

Table 13. Gain and Dynamic Range

Parameter	Symbol	Test Conditions	Min	Typ	Max	Unit
Absolute Levels	GAL	Maximum 0 dBm0 levels (1004 Hz): VFxl (encoder milliwatt), all programmable transmit gains set to 0 dB.	—	2.80	—	Vp-p
		RCV (decoder milliwatt), termination impedance off, all programmable receive gains set to 0 dB.	—	5.29	—	Vp-p
Absolute Levels	GAL	Minimum 0 dBm0 levels (1004 Hz): VFxl (encoder milliwatt), XAG = 24 dB, GTX1 = 6 dB, GTX2 = 0 dB.	—	87.5	—	mVp-p
		RCV (decoder milliwatt), termination impedance off, GRX1 = 0 dB, GRX2 = -6 dB.	—	2.63	—	Vp-p
Absolute Maximum Voltage Swings	GAL	VFxl	—	—	3.2	Vp-p
		VFR _{OP} to VFR _{ON} (differential).	—	—	5.28	Vp-p
Transmit Gain Absolute Accuracy	GXA	Transmit gain programmed for maximum 0 dBm0 test level, measured deviation of digital code from ideal 0 dBm0 level at DX digital outputs, with transmit gain set to 0 dB: 20 °C to 70 °C 0 °C to 85 °C -40 °C to +85 °C.	—	±0.15	—	dB
			-0.25	—	0.25	dB
			-0.30	—	0.30	dB
Transmit Gain Variation with Programmed Gain	GXAG	Measured transmit gain over the range from maximum to minimum, calculated deviation from the programmed gain relative to GXA at 0 dB, V _{DD} = 5 V.	-0.1	—	0.1	dB
Transmit Gain Variation with Frequency, 600 Ω Resistive Source Impedance and Synthesized Termination Impedance	GXAF	Relative to 1004 Hz, minimum gain < GX < maximum gain, VFxl = 0 dBm0 signal, path gain set to 0 dB:				
		f = 16.67 Hz	—	-50	-30	dB
		f = 40 Hz	—	-40	-26	dB
		f = 50 Hz	—	-40	-30	dB
		f = 60 Hz	—	-55	-30	dB
		f = 200 Hz	-3.0	-2.0	0	dB
		f = 300 Hz to 3000 Hz	-0.125	±0.04	0.135	dB
		f = 3140 Hz	-0.57	0.01	0.125	dB
		f = 3380 Hz	-0.735	-0.03	0.015	dB
		f = 3860 Hz	—	-8.8	-8.98	dB
f = 4600 Hz and above.	—	—	-32	dB		

Electrical Characteristics (continued)**Gain and Dynamic Range** (continued)**Table 13. Gain and Dynamic Range** (continued)

Parameter	Symbol	Test Conditions	Min	Typ	Max	Unit
Transmit Gain Variation with Signal Level	GXAL	Sinusoidal test method*, reference level = 0 dBm0†:				
		VFxl = -40 dBm0 to +3 dBm0	-0.25	—	0.25	dB
		VFxl = -50 dBm0 to -40 dBm0	-0.50	—	0.50	dB
		VFxl = -55 dBm0 to -50 dBm0.	-1.40	—	1.40	dB
Receive Gain Absolute Accuracy	GRA	Receive gain programmed to -6 dB, apply 0 dBm0 signal to IPCM, measure VRCV, RL = 100 kΩ differential:				
		20 °C to 70 °C	—	±0.15	—	dB
		0 °C to 85 °C	-0.25	—	0.25	dB
		-40 °C to +85 °C.	-0.30	—	0.30	dB
Relative Gain, VFROP to VFRON	—	Digital input 0 dBm0 signal, f = 300 Hz to 3400 Hz.	-0.01	—	0.01	dB
Relative Phase, VFROP to VFRON	—	Digital input 0 dBm0 signal, f = 300 Hz to 3400 Hz.	-0.25	—	0.25	Degrees
Receive Gain Variation with Programmed Gain	GRAG	Measure receive gain over the range from maximum to minimum setting, calculated deviation from the programmed gain relative to GRA at 0 dB, VDD = 5 V.	-0.1	—	-0.1	dB
Receive Gain Variation with Frequency, 600 Ω Resistive Termination	GRAF	Relative to 1004 Hz, digital input = 0 dBm0 code, minimum gain < GR < maximum gain, 0 dB path gain:				
		f = below 3000 Hz	-0.125	±0.04	0.125	dB
		f = 3140 Hz	-0.57	±0.04	0.125	dB
		f = 3380 Hz	-0.735	-0.550	0.015	dB
		f = 3860 Hz	—	-10.7	-8.98	dB
		f = 4600 Hz and above.	—	—	-28	dB
Receive Gain Variation with Signal Level	GRAL	Sinusoidal test method*, reference level = 0 dBm0:				
		IPCM digital level = -40 dBm0 to +3 dBm0	-0.25	—	0.25	dB
		IPCM digital level = -50 dBm0 to -40 dBm0	-0.50	—	0.50	dB
		IPCM digital level = -55 dBm0 to -50 dBm0.	-1.40	—	1.40	dB

* Applied to all four channels.

† RTZ and CTZ paths open.

Electrical Characteristics (continued)

Noise Characteristics

Table 14. Per-Channel Noise Characteristics

Parameter	Symbol	Test Conditions	Min	Typ	Max	Unit
Transmit Noise, C-Message Weighted	N _{XC}	0 dB transmit gain*.	—	7	18	dBrnC0
Transmit Noise, P-Message Weighted	N _{XP}	0 dB transmit gain*.	—	—	-68	dBm0p
Receive Noise, C-Message Weighted	N _{RC}	0 dB receive gain, digital pattern corresponding to idle PCM code, μ -law*.	—	0	13	dBrnC0
Receive Noise, P-Message Weighted	N _{RP}	0 dB receive gain, digital pattern corresponding to idle PCM code, A-law*.	—	—	-75	dBm0p
Noise, Single Frequency	N _{RS}	f = 0 kHz to 100 kHz, loop around measurement, $V_{VFXI} = 0$ Vrms.	—	—	-53	dBm0
Power Supply Rejection, Transmit	PSR _X	$V_{DD} = 5.0 V_{DC} + 100$ mVrms: f = 0 kHz to 4 kHz f = 4 kHz to 50 kHz C-message weighted.	36 30	— —	— —	dB dB
Power Supply Rejection, Receive	PSR _R	Measured on V_{FR0P} , $V_{DD} = 5.0 V_{DC} + 100$ mVrms: f = 0 kHz to 4 kHz f = 4 kHz to 25 kHz f = 25 kHz to 50 kHz.	36 40 36	— — —	— — —	dB dB dB
Spurious Out-of-Band Signals at the Chan- nel Outputs	SOS	0 dBm0, 300 Hz to 3400 Hz signal applied to V_{VFXI} , transmit gain set to 0 dB: 4600 Hz to 7600 Hz 7600 Hz to 8400 Hz 8.4 kHz to 50 kHz.	— — —	— — —	-30 -40 -30	dB dB dB

* $R_{VFXI} = 25 M\Omega$.

Electrical Characteristics (continued)**Distortion and Group Delay****Table 15. Distortion and Group Delay**

Parameter	Symbol	Test Conditions	Min	Typ	Max	Unit
Signal to Total Distortion, Transmit or Receive	STD _X STD _R	Sinusoidal test method level:				
		μ-law –30 dBm0 to +3 dBm0	36	—	—	dB
		A-law –30 dBm0 to +3 dBm0	35	—	—	dB
		μ-law –40 dBm0 to –30 dBm0	31	—	—	dB
		A-law –40 dBm0 to –30 dBm0	30	—	—	dB
		μ-law –45 dBm0 to –40 dBm0	27	—	—	dB
A-law –45 dBm0 to –40 dBm0.	25	—	—	dB		
Single Frequency Distortion, Transmit	SFD _X	0 dBm0 single frequency input, 200 Hz ≤ f _{IN} ≤ 3400 Hz; measured at any other single frequency.	—	—	–46	dB
Single Frequency Distortion, Receive	SFD _R	0 dBm0 single frequency input, 200 Hz ≤ f _{IN} ≤ 3400 Hz; measured at any other single frequency.	—	—	–46	dB
Intermodulation Distortion	IMD	Transmit or receive, two frequencies in the range of 300 Hz to 3400 Hz.	—	–55	–49	dB
TX Group Delay, Absolute*	DXA	f = 1600 Hz, 600 Ω resistive termination.	—	—	475	μs
RX Group Delay, Absolute*	DRA	f = 1600 Hz, 600 Ω resistive termination.	—	—	260	μs

* Absolute group delay is a function of time-slot assignment, and the maximum in this table refers to the optimal (minimum group delay) time-slot assignment.

Electrical Characteristics (continued)

Crosstalk

Table 16. Crosstalk

Parameter	Symbol	Test Conditions	Min	Typ	Max	Unit
Transmit to Transmit Crosstalk, 0 dBm0 Level	CT _{X-X}	f = 300 Hz to 3400 Hz, any channel to any channel.	—	-100	-80	dB
Transmit to Receive Crosstalk, 0 dBm0 Level	CT _{X-R}	f = 300 Hz to 3400 Hz, any channel to any other channel. In-channel.	— —	-100 -80	-80 -50	dB dB
Receive to Transmit Crosstalk, 0 dBm0 Level	CT _{R-X}	f = 300 Hz to 3400 Hz, any channel to any other channel. In-channel.	— —	-100 -70	-80 -50	dB dB
Receive to Receive Crosstalk, 0 dBm0 Level	CT _{R-R}	f = 300 Hz to 3400 Hz, any channel to any channel.	—	-100	-80	dB

Timing Characteristics

Control Interface Timing

Serial Control Port Timing

Table 17. Serial Control Port Timing (See Figures 22 and 23.)

Symbol	Parameter	Test Conditions	Min	Typ	Max	Unit
f _{DCLK}	Clock Frequency (all commands)	—	—	—	4096	kHz
t _{CSSETUP}	Chip Select Setup Time, Normal Mode	D _{CLK} = 4.096 MHz	7	—	—	ns
t _{CSHOLD}	Chip Select Hold Time, Normal Mode	D _{CLK} = 4.096 MHz	4	—	—	ns
t _{SDLY}	Output Data Delay, Normal Mode	D _{CLK} = 4.096 MHz	—	—	9	ns
t _{SDHOLD}	Input Data Hold Time, Normal Mode	D _{CLK} = 4.096 MHz	4	—	—	ns
t _{SDSETUP}	Input Data Setup Time, Normal Mode	D _{CLK} = 4.096 MHz	7	—	—	ns
t _{SDZ}	Output Data, High Impedance	D _{CLK} = 4.096 MHz	100	—	—	ns
t _{RISE}	Clock Edge Rise Time	D _{CLK} = 4.096 MHz	—	—	12	ns
t _{FALL}	Clock Edge Fall Time	D _{CLK} = 4.096 MHz	—	—	12	ns
t _{RISE} , t _{FALL}	Line Driver Rise/Fall Time (DO output)	I _L = 15 mA, C _{LOAD} = 100 pF	—	—	30	ns
t _{CSBHOLD}	Chip Select Hold Time, Byte-by-Byte Mode	D _{CLK} = 4.096 MHz	4	—	—	ns
t _{SDLY}	Output Data Delay, Byte-by-Byte Mode	D _{CLK} = 4.096 MHz*	—	—	9	ns
t _{CSBSETUP}	Chip Select Setup Time, Byte-by-Byte Mode	D _{CLK} = 4.096 MHz	7	—	—	ns
t _{SDBHOLD}	Data Hold Time, Byte-by-Byte Mode	D _{CLK} = 4.096 MHz	4	—	—	ns
t _{SDBSETUP}	Data Setup Time, Byte-by-Byte Mode	D _{CLK} = 4.096 MHz	7	—	—	ns

* The t_{SDLY} delay is from either D_{CLK} or CS, whichever transition is later, for the first bit of the byte.

Timing Characteristics (continued)

Control Interface Timing (continued)

Normal Mode

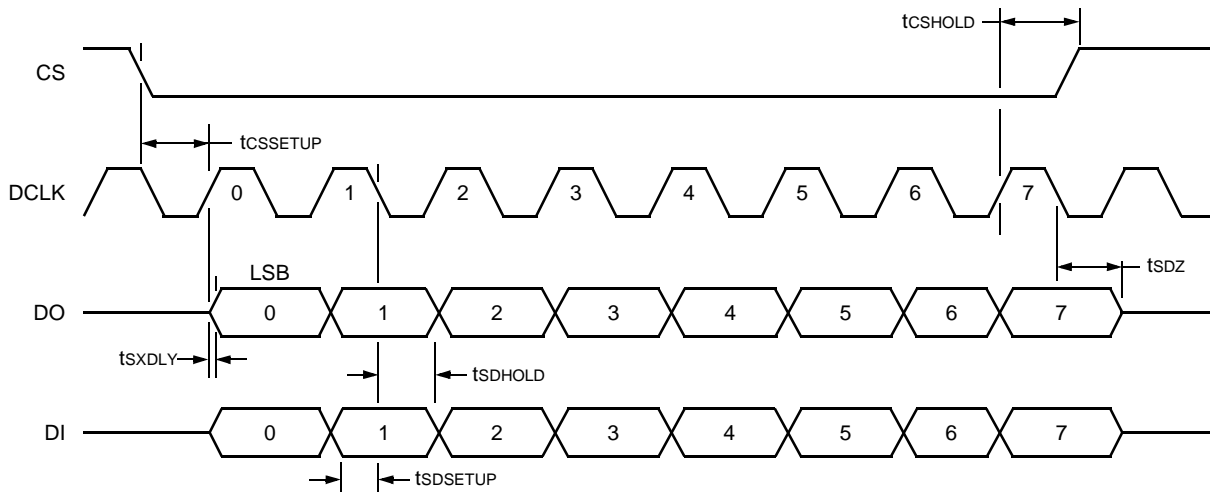

5-7185.f(F)

Figure 22. Serial Interface Timing, Normal Mode (One Byte Transfer and Continuous DCLK Shown)

Byte-by-Byte Mode

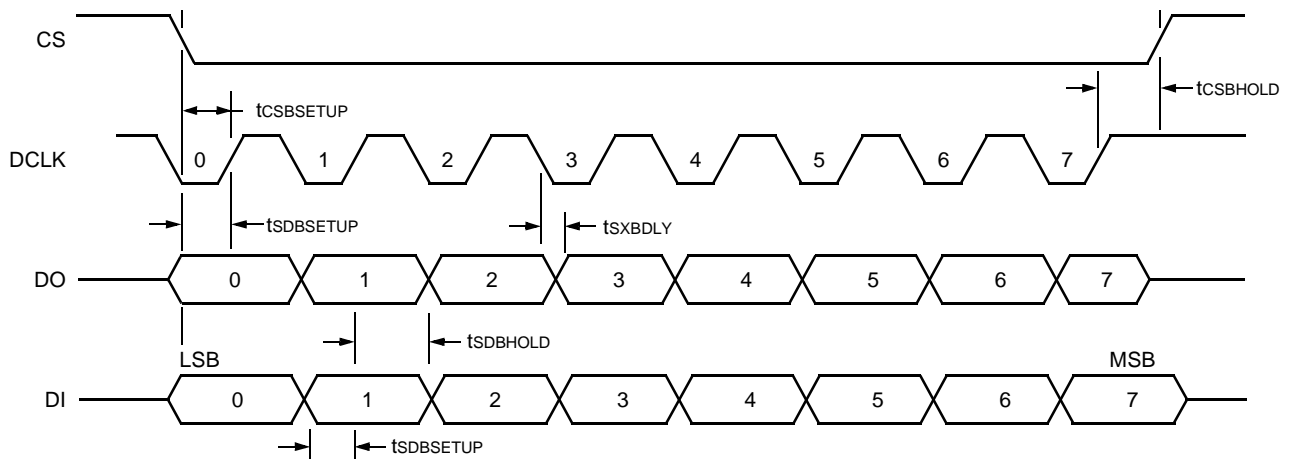

5-7186e (F)

Figure 23. Serial Interface Timing, Byte-by-Byte Mode (One Byte Transfer and Gapped DCLK Shown)

Timing Characteristics (continued)**PCM Interface Timing****Single-Clocking Mode**

Frame sync (FS) signifies the start of frame on the PCM bus for all four channels. FS occurs every 125 μ s at an 8 kHz rate. FS must be synchronous with the PCM bus clock (BCLK) and must be high for a minimum of one BCLK period. The PCM interface operates using fixed data rate timing, data timing for both transmit and receive are controlled by BCLK. BCLK can be any value from 512 kHz (eight time slots) to 16.384 MHz (256 time slots) as defined by Table 18.

The PCM bus transfers the most significant bit of the time slot first, consistent with normal telephony practice. Figure 24 shows FS, DX, and DR beginning on the

rising edge of BCLK and being latched on the falling edge of BCLK. Figure 25 shows DX and DR beginning, and FS being latched on the rising edge of BCLK, and DX and DR being latched on the falling edge of BCLK.

Figure 24 portrays a bit offset of zero, and Figure 25 portrays a transmit bit offset of one and a receive bit offset of two. Bit offset skews the PCM transmit and/or receive data independently from the FS reference. Up to seven BCLK cycles of bit offset can be employed on a per-channel basis. This flexibility can accommodate special timing requirements.

Linear coding is transmitted and received in two consecutive 8-bit time slots. $\overline{\text{TSX0}}$ or $\overline{\text{TSX1}}$ is active (low) when DX data is transmitting (8 bits for companded code, 16 bits for linear code).

Table 18. PCM Interface Timing: Single-Clocking Mode (See Figures 24 and 25.)

Symbol	Parameter	Test Conditions	Min	Typ	Max	Unit
f _{BCLK}	Allowable BCLK Frequencies	—	—	512	—	kHz
		—	—	1024	—	kHz
		—	—	1536	—	kHz
		—	—	2048	—	kHz
		—	—	3072	—	kHz
		—	—	4096	—	kHz
		—	—	8192	—	kHz
		—	—	16384	—	kHz
—	Jitter of BCLK	—	—	—	100 ns in 100 ms = 1 ppm	—
—	BCLK Duty Cycle	—	40	50	60	%
t _{FSSETUP}	Frame Strobe Setup Time	BCLK = 16.384 MHz	7	—	—	ns
t _{FSHOLD}	Frame Strobe Hold Time	BCLK = 16.384 MHz	4	—	—	ns
t _{FSWIDTH}	Frame Strobe Width	FS synchronous with BCLK	t _{BCLK}	—	125 μ s – t _{BCLK}	—
t _{XDLY}	Output Data Delay	BCLK = 16.384 MHz	—	—	9	ns
t _{IDHOLD}	Input Data Hold Time	BCLK = 16.384 MHz	4	—	—	ns
t _{IDSETUP}	Input Data Setup Time	BCLK = 16.384 MHz	7	—	—	ns
t _{RISE}	Clock Edge Rise Time	BCLK = 16.384 MHz	—	—	8	ns
t _{FALL}	Clock Edge Fall Time	BCLK = 16.384 MHz	—	—	8	ns
t _{RISE} , t _{FALL}	DX Output Rise/Fall Time	I _L = 15 mA, C _{LOAD} = 100 pF	—	—	30	ns
t _{DXHIGHZ}	DX Output Data Float on TS Exit	C _{LOAD} = 0	—	—	5	ns
t _{TSXDELAY}	Line Driver Enable Delay	—	—	—	5	ns
t _{TSXHIGHZ}	Line Driver Enable Float on TS Exit	—	—	—	5	ns

Timing Characteristics (continued)

PCM Interface Timing (continued)

Single-Clocking Mode (continued)

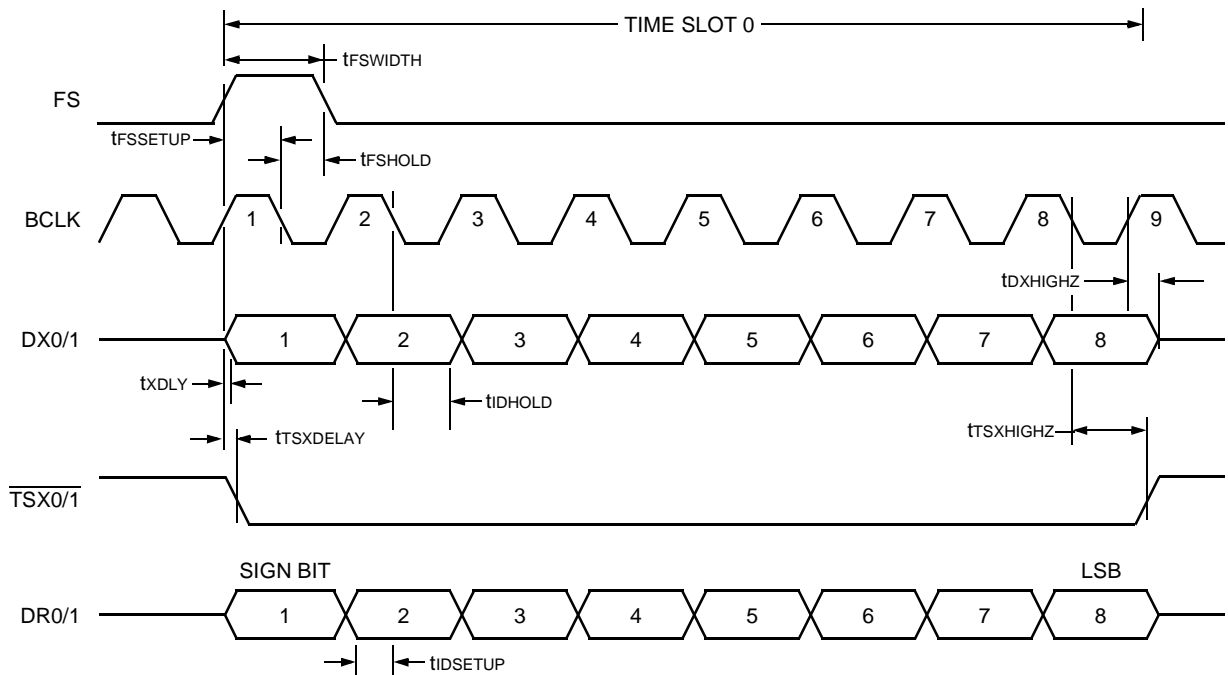

5-7188d F

Figure 24. Single-Clocking Mode (TXBITOFF = 0, RXBITOFF = 0, PCMCTRL2 = 0x00)

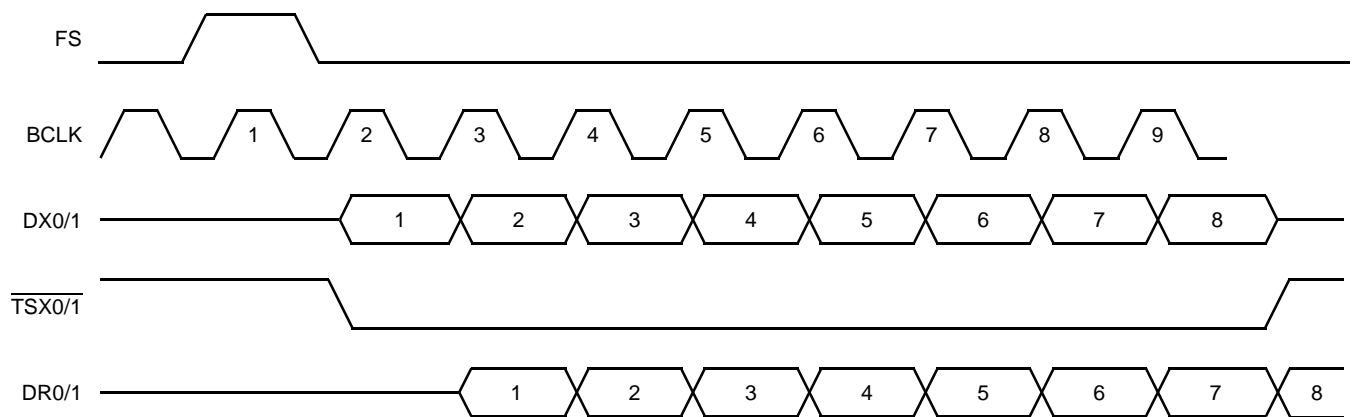

5-7185.g F

Figure 25. Single-Clocking Mode (TXBITOFF = 1, RXBITOFF = 2, PCMCTRL2 = 0x01)

Timing Characteristics (continued)**PCM Interface Timing** (continued)**Double-Clocking Mode**

As with the single-clocking mode, FS signifies the start of frame on the PCM bus for all four channels and occurs every 125 μ s at an 8 kHz rate. FS must be synchronous with BCLK and must be high for a minimum of one BCLK period. The PCM interface operates using fixed data rate timing; data timing for both transmit and receive are controlled by BCLK. In double-clocking mode, however, BCLK runs at twice the PCM data rate. BCLK can be any value from 512 kHz (data rate of 256 kbits/s, 4 time slots) to 16.384 MHz (data rate of 8192 kbits/s, 128 time slots) as defined by Table 19.

In Figure 26, detail A, the falling edge of the first BCLK latches FS. The falling edge of the second BCLK latches DR (receive bit offset of 1). DX starts on the rising edge of the first BCLK. The PCM bus transfers the most significant bit of the data first.

The codec defaults to FS and DR being latched on the first BCLK cycle. To latch DR on the second BCLK cycle, program receive bit offset for 1 (RXBITOFF = 0x20). For every bit programmed (0 to 7), bit offset shifts transmit or receive data by one BCLK cycle. Therefore, in double-clock mode, the time-slot assignment and bit offset registers need to be used in tandem in order to achieve a full range of bit offset values. For instance, in time-slot 0, bit offset will shift data up to four bits. To shift data 5 to 8 bits, time slot 1 needs to be selected.

Linear coding is not allowed in double-clocking mode. $\overline{\text{TSX0}}$ or $\overline{\text{TSX1}}$ (not shown in Figure 26) is active (low) when DX data is transmitting.

Note that the device reverts back to single-clock mode if reset (address 128, bit 0). Internal states of the codec can be reset without going out of double-clock mode (address 128, bit 1).

Table 19. PCM Interface Timing: Double-Clocking Mode (See Figure 26.)

Symbol	Parameter	Signal	Min	Typ	Max	Unit
fBCLK	Allowable BCLK Frequencies	BCLK	—	512	—	kHz
			—	1024	—	kHz
			—	1536	—	kHz
			—	2048	—	kHz
			—	3072	—	kHz
			—	4096	—	kHz
			—	8192	—	kHz
			—	16384	—	kHz
—	Jitter of BCLK	BCLK	—	—	100 ns in 100 ms = 1 ppm	—
tBCL	Clock Period	BCLK	61	—	1953	ns
tR, tF	Clock Rise/Fall	BCLK	—	—	8	ns
tWL, tWH	Pulse Width	BCLK	tBCL x 0.4	—	tBCL x 0.6	ns
tR, tF	Frame Rise/Fall	FS	—	—	15	ns
tWFH	Frame Width High	FS	tBCL	—	—	ns
tWFL	Frame Width Low	FS	tBCL	—	—	ns
tSF	Frame Setup	FS	7	—	tBCL – 50	ns
tHF	Frame Hold	FS	4	—	—	ns
tDDC	Data Delay Clock	DX	—	—	9	ns
tDDF	Data Delay Frame	DX	—	—	9	ns
tSD	Data Setup	DR	7	—	—	ns
tHD	Data Hold	DR	4	—	—	ns

Note: DX load = 150 pF.

Timing Characteristics (continued)

PCM Interface Timing (continued)

Double-Clocking Mode (continued)

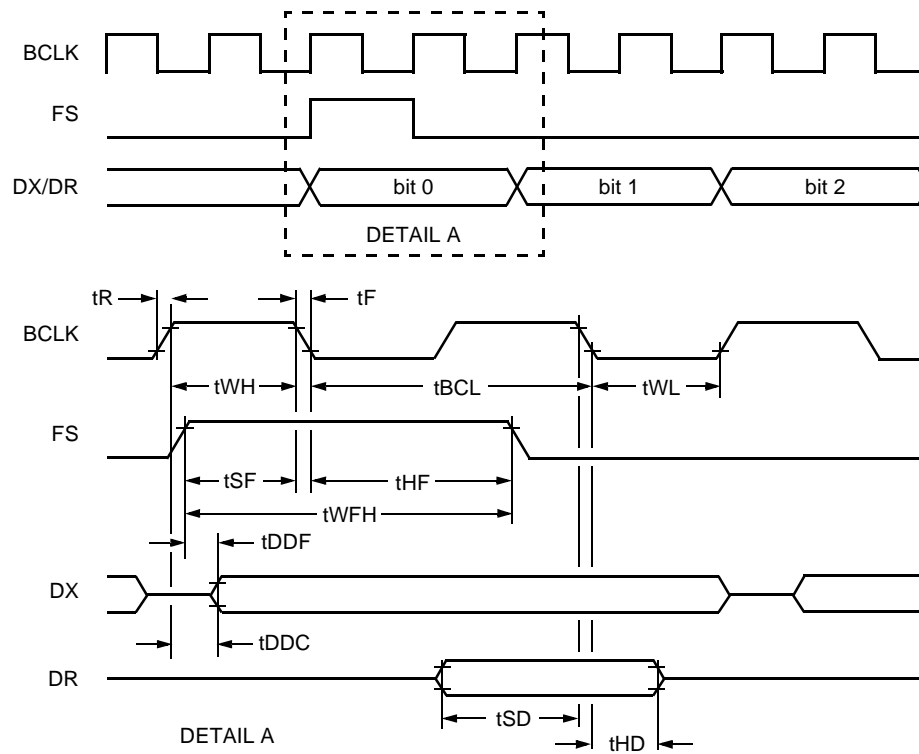

5-7173F

Figure 26. Double-Clocking Mode (RXBITOFF = 0x20, PCMCTRL2 = 0x00)

Software Interface

Table 20. Memory Mapping

With the exceptions noted, all of these memory locations may be read to determine the state of the controls contained therein. In the following table, bit 0 is the LSB (transmitted first on the serial interface) and bit 7 is the most significant bit of the byte. Unused bits in an address or multibyte address should be loaded as zero. All of the memory locations can be programmed on a per-channel basis.

Note that the entire coefficient set for a channel (or all four channels) may be loaded with one command.

Control Name	Address (Decimal)	# of Bits Used	Default Value	Description
HBALTAPS	0—27 64—91	448	See Table 21	Balance impedance tap coefficients.
Reserved	28—63 92—127	—	—	These addresses have no function.
RESCTRL	128	2	0x00	Reset address. Writing a one in the used positions causes a reset as defined by the bit definition. This reset remains in force until the bit is written as a zero.
CHACTIVE	129	1	0x00	Standby/active control.
RXBITOFF	130	4	0x00	Bit offset for receive direction.
RXOFF	131	8	16 * channel #	Time-slot assignment for receive direction.
GRX1	132—133	11	0x0400	Gain transfer for receive direction.
GRX2	134—135	11	0x01ac	Gain tweaking. Control of gain sensitive to impedance and SLIC parameter choices, receive direction.
Reserved	136—139	—	—	This address has no function.
CTZCTRL	140—143	31	07ed0000	CTZ bleed coefficients.
Reserved	144	—	—	This address has no function.
PCMCTRL2	145	6	0x00	PCM transmission and sampling edge control.
SDCTRL	146	7	0x19	RTZ, transmit analog gain (XAG), and digital loopback 3 controls.
SDTSI	147	7	17 * channel #	Internal time-slot interchanger and loopback controls. Default sets external pins to state referenced in this data sheet.
GTX2	148—149	12	0x0400	Gain transfer for transmit direction.
ZEQTX	150—152	21	0x000000	Transmit line equalization.
GTX1	153—154	12	0x051a	Gain tweaking. Control of gain sensitive to impedance and SLIC parameter choices, transmit direction.
TXBITOFF	155	4 or 5	0x00	Bit offset for transmit direction.
TXOFF	156	8	16 * channel #	Time-slot assignment for transmit direction.
PCMCTRL1	157	7	0x00	PCM, companding, and loopback controls.
SLICTS	158	6	0x0c	SLIC 3-state control. Latch I/O.
SLICWR	159	6	0x00	Data to be written to the SLIC latches if the corresponding bit is set in the SLICTS control word.
SLICRD	160	6	—	Current actual state of the SLIC leads. This will be the same as SLICWR for those leads configured as outputs. All other positions will reflect the actual state of the external lead. A write operation to this word will be ignored, and within one PCM frame (125 μ s), the data will be overwritten.
Reserved	161	—	—	This address has no function.
VERIFY	162	8	0x00	Test address for serial interface verification.

Software Interface (continued)

The following table shows the control bit assignments in the memory control addresses. In all control bit cases, the bit being set places the function into the active mode as defined in the function column.

Table 21. Control Bit Definition

Control Name (Address, Decimal) [Address, Hex]	Bit Assignment(s)	Function
HBALTAPS (0—27, 64—91) [0x00—0x1b, 0x40—0x5b]	448	Balance impedance coefficients. Default value is 0x00 for all bytes except for addresses 3 and 5, which are 0x80, and address 69, which is 0x88.
RESCTRL (128) [0x80]	2—7	Not used, load as zeros.
	1	A one resets all other internal states. Control addresses are not reset.
	0	A one resets all control addresses to default values. Note that setting this bit will result in it and all others of this word becoming cleared on the next PCM frame as a normal part of the reset functionality. Alternatively, hardware reset can be used to reset all control and state functions. It is necessary to wait at least 256 μ s after asserting this bit before initiating any other serial I/O transactions.
CHACTIVE (129) [0x81]	1—7	Load as zeros.
	0	Active/standby mode. A zero causes the channel to enter standby (low-power) mode and disables the PCM interface for this channel. A one activates the channel and the corresponding PCM bus interface. Default is zero.
RXBITOFF (130) [0x82]	5—7	Receive direction bit offset for the FS signal. Defaults to zero. These 3 bits can be thought of as the least significant bits (RXOFF contains the more significant bits) of a bit counter that determines the location of the first bit of the PCM data from FS.
	0—4	Load as zeros.
RXOFF (131) [0x83]	0—7	Receive time-slot assignment. Defaults to (16 * channel number). Each time slot represents 8 bits; allow for two time slots when using linear mode or double-clock mode.
GRX1 (132—133) [0x84—0x85]	0—10	Gain adjustment for gain transfer stage in receive direction. Defaults to 0x0400 (0 dB). This is an 11-bit multiply operation with a maximum gain of two (6 dB). 0 dB is the maximum recommended setting.
GRX2 (134—135) [0x86—0x87]	0—10	Gain adjustment for tweak gain stage in receive direction. Defaults to 0x01ac (-7.58 dB). This is an 11-bit multiply operation with a maximum gain of two (6 dB). 0 dB is the maximum recommended setting.
CTZCTRL (140—143) [0x8c—0x8f]	0—30	Coefficients for the CTZ termination bleed. Defaults to 0x07ed0000.

Software Interface (continued)

Table 21. Control Bit Definition (continued)

Control Name (Address, Decimal) [Address, Hex]	Bit Assignment(s)	Function																													
PCMCTRL2 (145) [0x91]	6—7	Load as zeros.																													
	5	A one selects DX PCM port 1. A zero selects DX PCM port 0. Defaults to zero. PCM port 1 is not available in all package types.																													
	4	A one selects DR PCM port 1. A zero selects DR PCM port 0. Defaults to zero. PCM port 1 is not available in all package types.																													
	3	A one selects double-clocking mode. Defaults to zero (single-clocking mode). A write to any channel affects all four channels.																													
	2	A one starts transmit data on a falling BCLK edge. A zero starts transmit data on a rising BCLK edge. Defaults to zero. A write to any channel affects all four channels.																													
	1	A one latches receive data on a rising BCLK edge. A zero latches receive data on a falling BCLK edge. Defaults to zero. A write to any channel affects all four channels.																													
	0	A one latches FS on a rising BCLK edge. A zero latches FS on a falling BCLK edge. Defaults to zero. A write to any channel affects all four channels.																													
SDCTRL (146) [0x92]	7	Load as zero.																													
	6	Enable digital loopback 3 . Defaults to zero (no loopback).																													
	3—5	RTZ gain. Defaults to 3 (equal level point value of $3 * 0.075 = 0.225$). Turn off by writing to zero.																													
	0—2	Transmit analog gain (XAG). Defaults to 1 (6 dB) gain.	<table border="1"> <thead> <tr> <th colspan="3">Bit Number</th> <th>Function (dB)</th> </tr> <tr> <th>2</th> <th>1</th> <th>0</th> <th></th> </tr> </thead> <tbody> <tr> <td>0</td> <td>0</td> <td>0</td> <td>0.0</td> </tr> <tr> <td>0</td> <td>0</td> <td>1</td> <td>6.02</td> </tr> <tr> <td>0</td> <td>1</td> <td>0</td> <td>12.04</td> </tr> <tr> <td>0</td> <td>1</td> <td>1</td> <td>18.06</td> </tr> <tr> <td>1</td> <td>0</td> <td>0</td> <td>24.08</td> </tr> </tbody> </table>	Bit Number			Function (dB)	2	1	0		0	0	0	0.0	0	0	1	6.02	0	1	0	12.04	0	1	1	18.06	1	0	0	24.08
			Bit Number			Function (dB)																									
			2	1	0																										
0			0	0	0.0																										
0			0	1	6.02																										
0	1	0	12.04																												
0	1	1	18.06																												
1	0	0	24.08																												
SDTSI (147) [0x93]	7	Load as zero.																													
	6	Digital loopback, receive to transmit at the sigma-delta converters (digital loopback 2). Defaults to zero (no loopback).																													
	4—5	Analog channel feeding this digital channel in the transmit direction. Defaults to channel number.																													
	3	Send idle-channel code (alternating bits) to this analog receive path. Defaults to zero (off).																													
	2	Loopback from transmit to receive at the sigma-delta converters (analog loopback 1). Defaults to zero (no loopback).																													
	0—1	Digital channel feeding this analog receive channel. Defaults to channel number.																													
GTX2 (148—149) [0x94—0x95]	0—11	Gain control for gain transfer stage in transmit direction. Defaults to 0x0400 (0 dB). This is a 12-bit multiply operation with a maximum gain of four (12 dB).																													
ZEQTX (150—152) [0x96—0x98]	0—20	Coefficients for the transmit equalization stage. Varies frequency response and accommodates current-sensing SLICs. Defaults to 0x000000.																													

Software Interface (continued)

Table 21. Control Bit Definition (continued)

Control Name (Address, Decimal) [Address, Hex]	Bit Assignment(s)	Function
GTX1 (153—154) [0x99—0x9a]	0—11	Gain control for tweak gain stage in transmit direction. Defaults to 0x051a (2.11 dB). This is a 12-bit multiply operation with a maximum gain of four (12 dB).
TXBITOFF (155) [0x9b]	5—7	Transmit direction bit offset for the FS signal. Defaults to zero. These 3 bits can be thought of as the least significant bits (TXOFF contains the more significant bits) of a bit counter that determines the location of the first bit of the PCM data from FS.
	0—4	Load as zeros.
TXOFF (156) [0x9c]	0—7	Transmit time-slot assignment. Defaults to (16 * channel number). Each time slot represents 8 bits; allow for two time slots when using linear mode or double-clock mode.
PCMCTRL1 (157) [0x9d]	7	3-state transmit PCM interface. Defaults to zero. A one forces the PCM interface into a high-impedance state during its assigned time-slot on the PCM bus. Placing the channel in standby mode also forces a high-impedance condition on the transmit interface.
	6	Transmit zeros instead of data. Defaults to zero (off).
	5	Linear mode significant bit. A one sets MSB first for both PCM transmit data output and for PCM receive data input. A zero sets both PCM paths to LSB first. Defaults to zero, LSB first.
	4	Place idle-channel code on receive path. Defaults to zero (off).
	3	Loopback receive to transmit at PCM conversion interface (digital loopback 1). Defaults to zero (no loopback).
	2	Loopback transmit to receive at PCM conversion interface (analog loopback 2). Defaults to zero (no loopback).
	1	Linear/compressed mode. A one sets 16-bit linear mode with two adjacent time slots used. Linear data is in two's complement form. Linear mode is only available when using single-clocking mode. A zero sets compressed mode with only one time slot used. Defaults to zero. Linear mode is programmed as LSB or MSB first using bit 5 of this word.
	0	μ -law or A-law. A one sets A-law mode, and a zero sets μ -law mode. Defaults to zero (μ -law).
SLICTS (158) [0x9e]	6—7	Load as zeros.
	0—5	Controls the drivers for the corresponding SLIC latches. A one enables the lead as an output. Defaults to 0x0C (bits 2 and 3 set, the rest cleared).
SLICWR (159) [0x9f]	6—7	Load as zeros.
	0—5	SLIC data latches. If the corresponding bit in the SLICTS address is set for an output, the device will drive the corresponding bit according to the contents of this address. Writes are performed within 125 μ s. Wait 125 μ s before a subsequent write to the same channel or between write all channel commands. Default is zero.
SLICRD (160) [0xa0]	6—7	Not used, ignore on read.
	0—5	Reports the actual state of the SLIC leads. Anything written to this address is ignored. Updates within 125 μ s.
VERIFY (162) [0xa2]	0—7	Test location for serial interface. This location has no internal use, but merely latches write data for the purpose of testing the serial interface. This register does not clear with reset.

Applications

The following reference circuit shows a complete schematic for interfacing to the Agere L9215G SLIC. All ac parameters are programmed by the T8536B. Note that this implementation differentiates itself in that no external components are required in the ac interface to provide a dc termination impedance or for stability. For illustration purposes, 0.5 Vrms PPM injection was assumed in this example and no meter pulse rejection is used. Also, this example illustrates the device using programmable overhead and current limit.

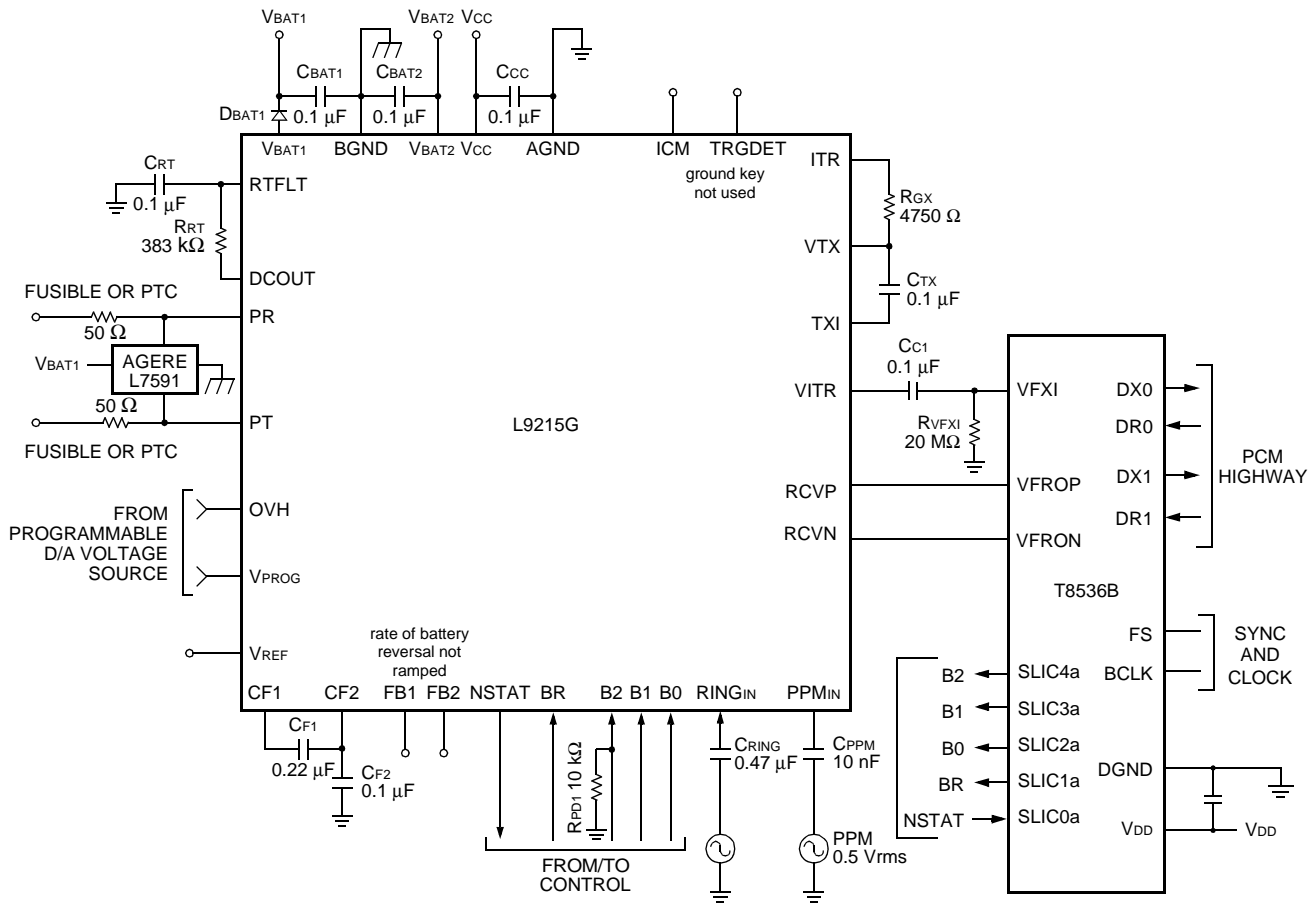

12-3534.y (F)

Figure 27. POTS Interface

Outline Diagrams

100-Pin TQFP

Dimensions shown are in millimeters.

Note: The dimensions in this outline diagram are intended for informational purposes only.
For detailed schematics to assist your design efforts, please contact your Agere Sales Representative.

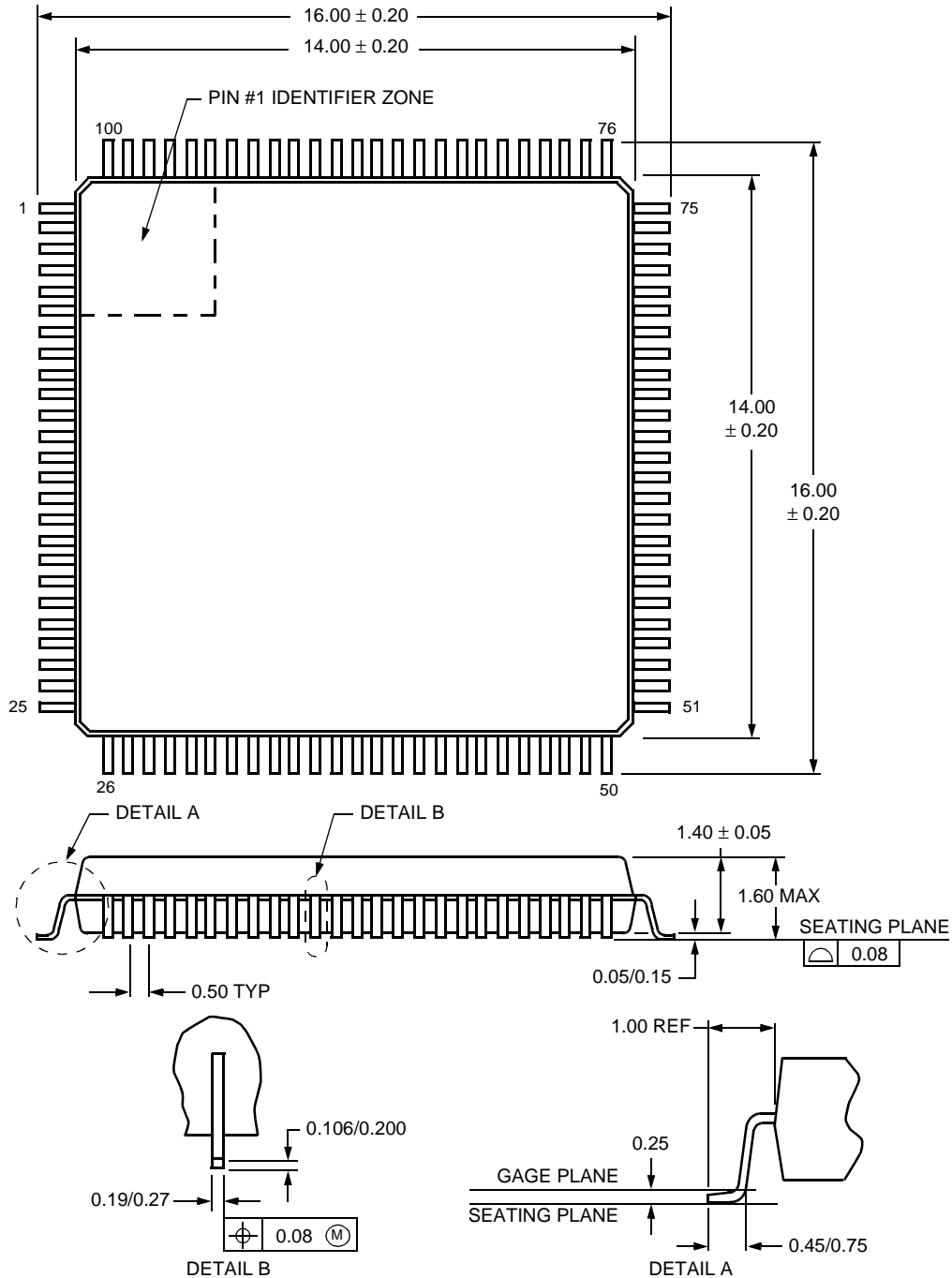

5-2146F

Outline Diagrams (continued)

68-Pin PLCC

Dimensions shown are in millimeters.

Note: The dimensions in this outline diagram are intended for informational purposes only.
For detailed schematics to assist your design efforts, please contact your Agere Sales Representative.

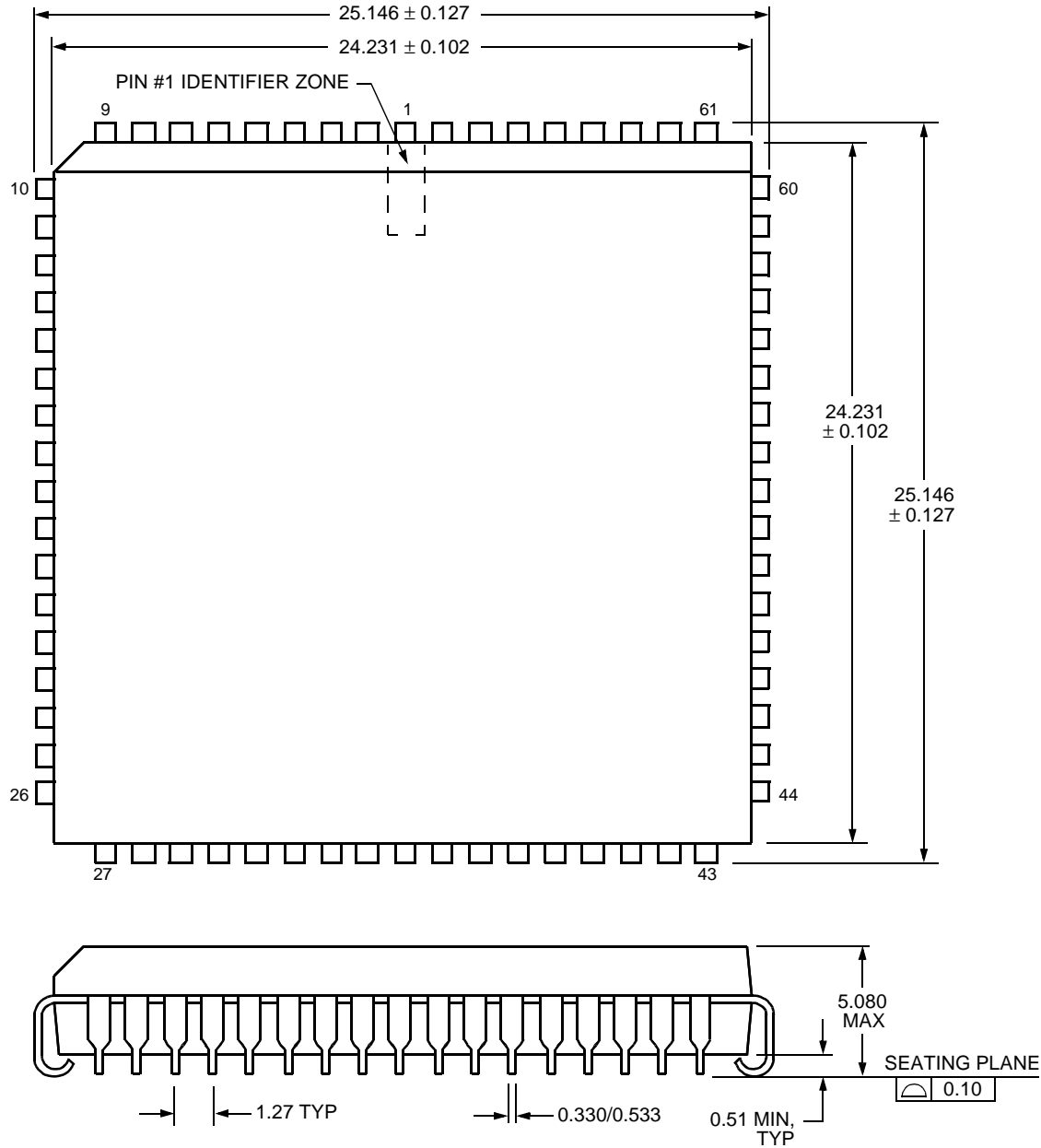

5-2139

Outline Diagrams (continued)

64-Pin TQFP

Dimensions shown are in millimeters.

Note: The dimensions in this outline diagram are intended for informational purposes only.
For detailed schematics to assist your design efforts, please contact your Agere Sales Representative.

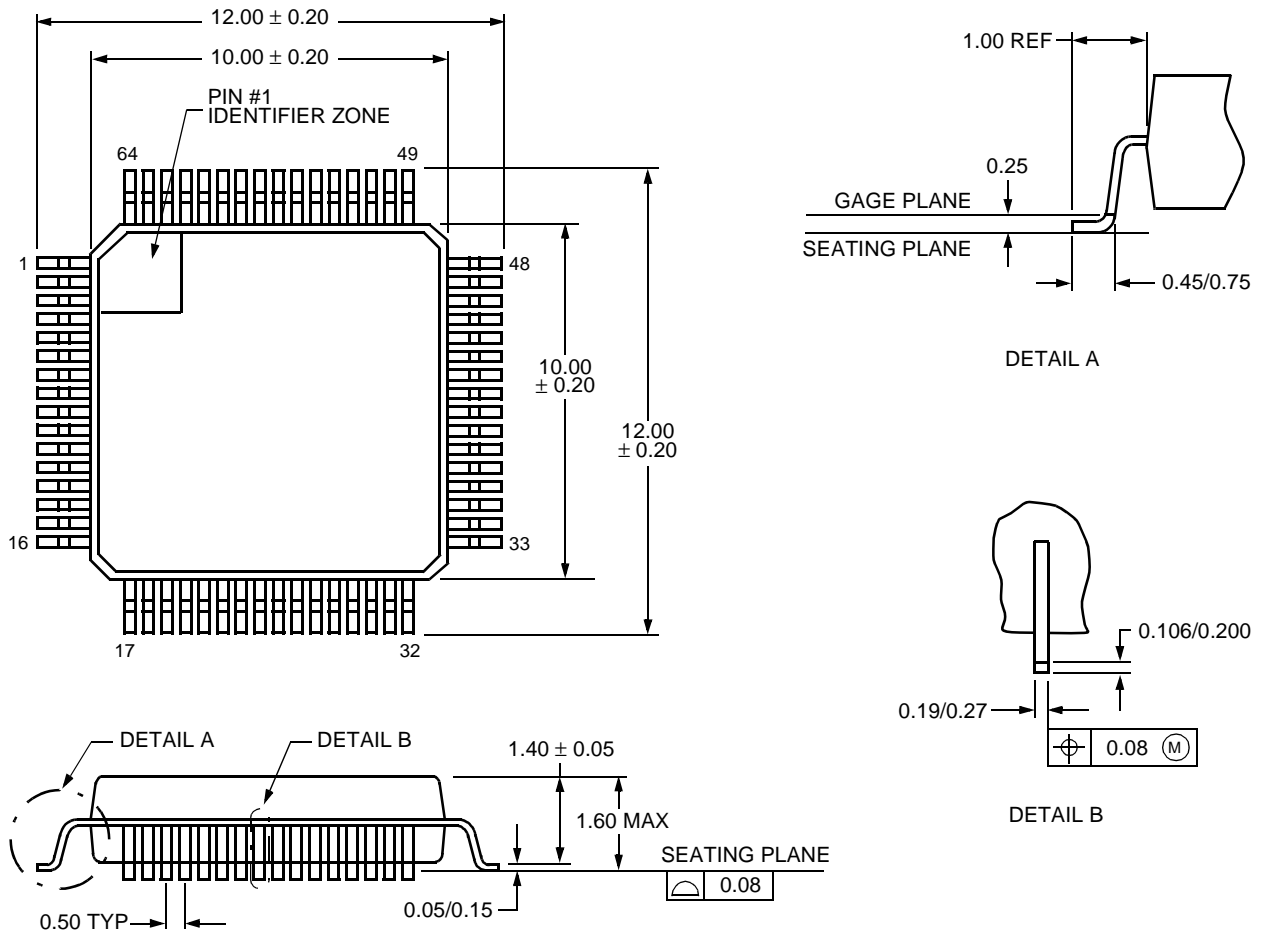

5-3080

Outline Diagrams (continued)

44-Pin PLCC

Dimensions are in millimeters.

Note: The dimensions in this outline diagram are intended for informational purposes only.
For detailed schematics to assist your design efforts, please contact your Agere Sales Representative.

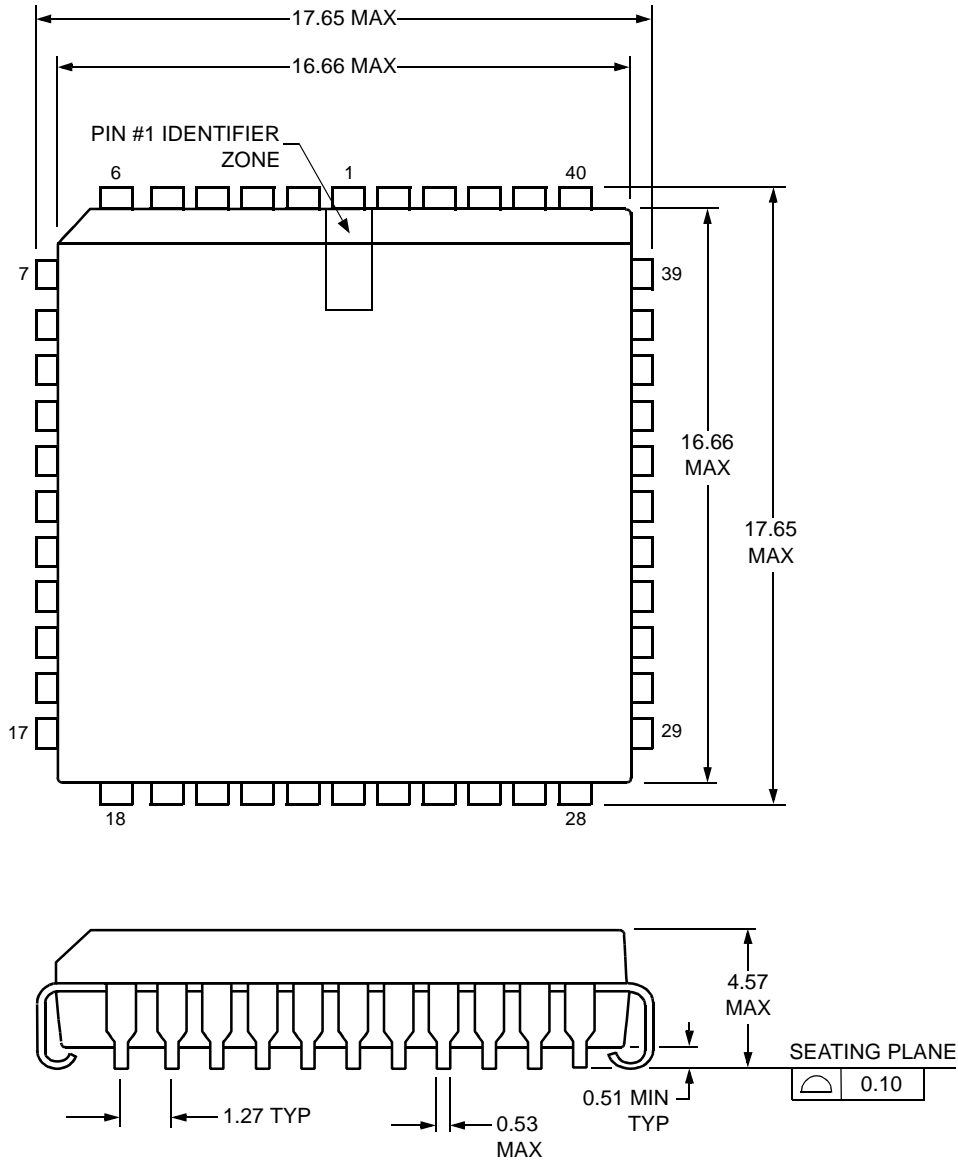

5-2506(F)

Ordering Information

Device Code	Package	Temperature	Comcode
T8535B - - - ML-D	44-Pin PLCC Dry-bagged	-40 °C to +85 °C	109059824
T8536B - - - ML-D	68-Pin PLCC Dry-bagged	-40 °C to +85 °C	109059816
T8536B - - 1TL-DB	100-Pin TQFP Dry Pack Tray	-40 °C to +85 °C	109059790
T8536B - - - TL-DB	64-Pin TQFP Dry Pack Tray	-40 °C to +85 °C	109059808

Telcordia Technologies is a trademark of Telcordia Technologies, Inc.

For additional information, contact your Agere Systems Account Manager or the following:

INTERNET: <http://www.agere.com>

E-MAIL: docmaster@agere.com

N. AMERICA: Agere Systems Inc., 555 Union Boulevard, Room 30L-15P-BA, Allentown, PA 18109-3286

1-800-372-2447, FAX 610-712-4106 (In CANADA: **1-800-553-2448**, FAX 610-712-4106)

ASIA: Agere Systems Hong Kong Ltd., Suites 3201 & 3210-12, 32/F, Tower 2, The Gateway, Harbour City, Kowloon

Tel. (852) 3129-2000, FAX (852) 3129-2020

CHINA: **(86) 21-5047-1212** (Shanghai), **(86) 10-6522-5566** (Beijing), **(86) 755-695-7224** (Shenzhen)

JAPAN: **(81) 3-5421-1600** (Tokyo), KOREA: **(82) 2-767-1850** (Seoul), SINGAPORE: **(65) 778-8833**, TAIWAN: **(886) 2-2725-5858** (Taipei)

EUROPE: **Tel. (44) 7000 624624**, FAX (44) 1344 488 045

Agere Systems Inc. reserves the right to make changes to the product(s) or information contained herein without notice. No liability is assumed as a result of their use or application.